

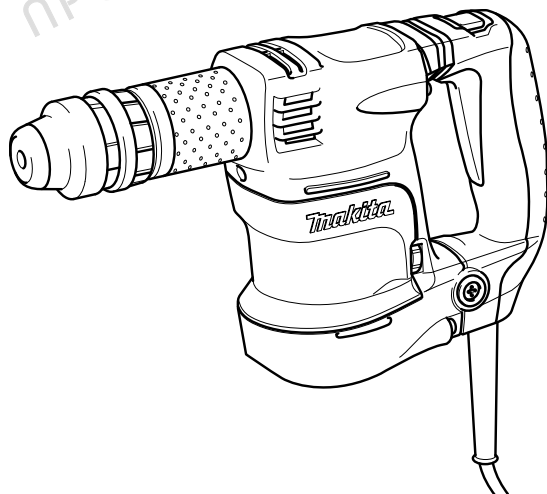

GB	Power Scraper	Instruction manual
F	Décapeur	Manuel d'instructions
D	Leichter Meißelhammer	Betriebsanleitung
I	Raschiatore elettrico	Istruzioni per l'uso
NL	Elektrische bikker	Gebruiksaanwijzing
E	Raspadora	Manual de instrucciones
P	Martelete Rompedor	Manual de instruções
DK	El-mejselhammer	Brugsanvisning
GR	Μηχανοκίνητος ξύστης	Οδηγίες χρήσης

HK1820

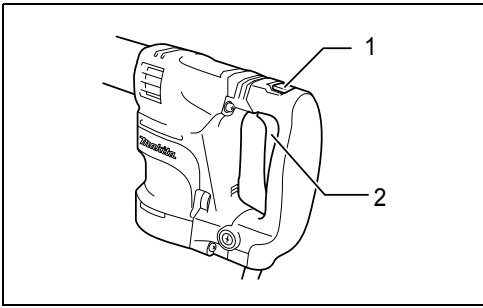



1

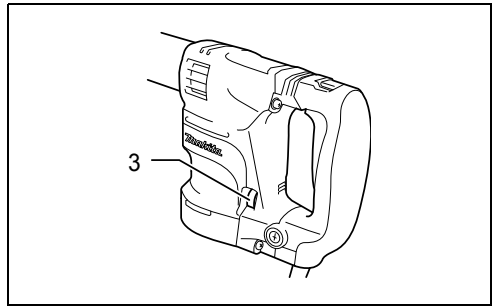

2

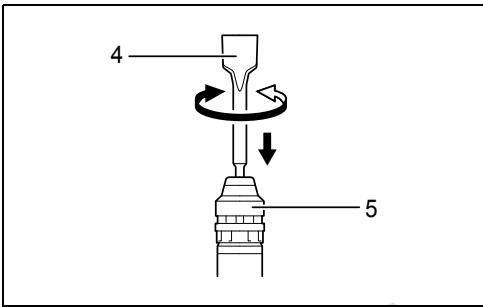

3

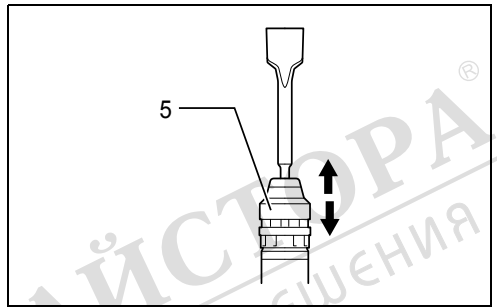

4

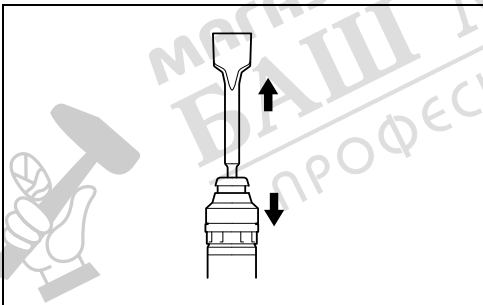

5

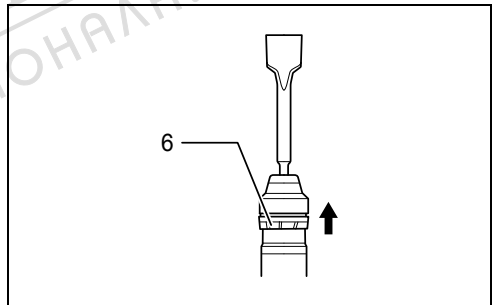

6

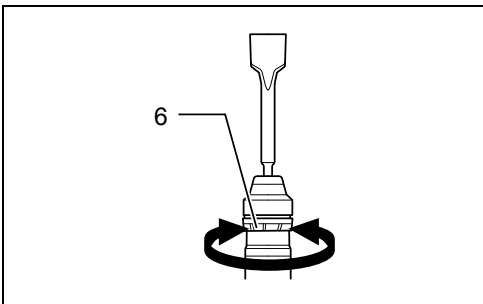

7

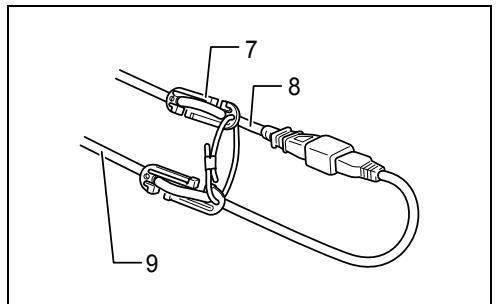

8

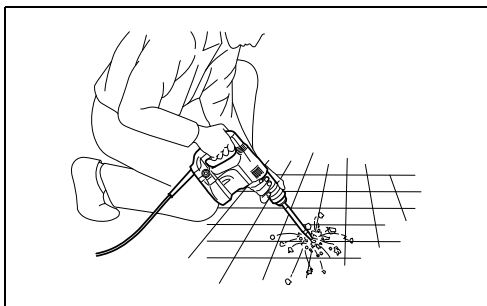

9

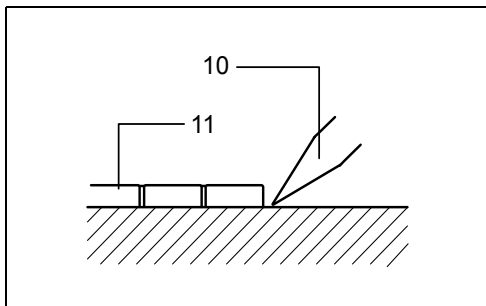

10

МАГАЗИН
БАШ МАЙСТОРА[®]
ПРОФЕСІОНАЛНИ РЕШЕННЯ

ENGLISH (Original instructions)

Explanation of general view

- | | | |
|-------------------|----------------------|--------------------|
| 1. Lock button | 5. Chuck cover | 9. Extension cord |
| 2. Switch trigger | 6. Change ring | 10. Scaling chisel |
| 3. Adjusting dial | 7. Hook | 11. Tile |
| 4. Bit | 8. Power supply cord | |

SPECIFICATIONS

Model	HK1820
Blows per minute (min ⁻¹)	0 - 3,200
Overall length	351 mm
Net weight	3.4 kg
Safety class	□/II

- Due to our continuing program of research and development, the specifications herein are subject to change without notice.
- Specifications may differ from country to country.
- Weight according to EPTA-Procedure 01/2014

Intended use

ENE047-1

The tool is intended for chiselling work in concrete, brick and stone as well as for driving and compacting with appropriate accessories.

Power supply

ENF002-2

The tool should be connected only to a power supply of the same voltage as indicated on the nameplate, and can only be operated on single-phase AC supply. They are double-insulated and can, therefore, also be used from sockets without earth wire.

General power tool safety warnings

GEA010-2

⚠ WARNING: Read all safety warnings, instructions, illustrations and specifications provided with this power tool. Failure to follow all instructions listed below may result in electric shock, fire and/or serious injury.

Save all warnings and instructions for future reference.

The term "power tool" in the warnings refers to your mains-operated (corded) power tool or battery-operated (cordless) power tool.

HAMMER SAFETY WARNINGS

GEB242-1

Safety instructions for all operations

1. **Wear ear protectors.** Exposure to noise can cause hearing loss.
2. **Use auxiliary handle(s), if supplied with the tool.** Loss of control can cause personal injury.
3. **Hold the power tool by insulated gripping surfaces, when performing an operation where the cutting accessory may contact hidden wiring or its own cord.** Cutting accessory contacting a "live" wire

may make exposed metal parts of the power tool "live" and could give the operator an electric shock.

ADDITIONAL SAFETY RULES

1. **Wear a hard hat (safety helmet), safety glasses and/or face shield. Ordinary eye or sun glasses are NOT safety glasses. It is also highly recommended that you wear a dust mask and thickly padded gloves.**
2. **Be sure the bit is secured in place before operation.**
3. **Under normal operation, the tool is designed to produce vibration. The screws can come loose easily, causing a breakdown or accident. Check tightness of screws carefully before operation.**
4. **In cold weather or when the tool has not been used for a long time, let the tool warm up for a while by operating it under no load. This will loosen up the lubrication. Without proper warm-up, hammering operation is difficult.**
5. **Always be sure you have a firm footing. Be sure no one is below when using the tool in high locations.**
6. **Hold the tool firmly with both hands.**
7. **Keep hands away from moving parts.**
8. **Do not leave the tool running. Operate the tool only when hand-held.**
9. **Do not point the tool at any one in the area when operating. The bit could fly out and injure someone seriously.**
10. **Do not touch the bit or parts close to the bit immediately after operation; they may be extremely hot and could burn your skin.**
11. **Do not operate the tool at no-load unnecessarily.**
12. **Some material contains chemicals which may be toxic. Take caution to prevent dust inhalation and skin contact. Follow material supplier safety data.**

SAVE THESE INSTRUCTIONS.

WARNING:

DO NOT let comfort or familiarity with product (gained from repeated use) replace strict adherence to safety rules for the subject product. **MISUSE** or failure to follow the safety rules stated in this instruction manual may cause serious personal injury.

FUNCTIONAL DESCRIPTION

CAUTION:

- Always be sure that the tool is switched off and unplugged before adjusting or checking function on the tool.

Switch action (Fig. 1)

CAUTION:

- Before plugging in the tool, always check to see that the switch trigger actuates properly and returns to the "OFF" position when released.

To start the tool, simply pull the switch trigger. Tool speed is increased by increasing pressure on the switch trigger. Release the switch trigger to stop.

For continuous operation, pull the switch trigger and then push in the lock button.

To stop the tool from the locked position, pull the switch trigger fully, then release it.

Speed change (Fig. 2)

The blows per minute can be adjusted just by turning the adjusting dial. This can be done even while the tool is running. The dial is marked 1 (lowest speed) to 5 (full speed).

Refer to the table below for the relationship between the number settings on the adjusting dial and the blows per minute.

Number on adjusting dial	Blows per minute
5	3,200
4	2,900
3	2,600
2	2,300
1	2,000

CAUTION:

- The speed adjusting dial can be turned only as far as 5 and back to 1. Do not force it past 5 or 1, or the speed adjusting function may no longer work.

ASSEMBLY

CAUTION:

- Always be sure that the tool is switched off and unplugged before carrying out any work on the tool.

Installing or removing the bit (Fig. 3)

Clean the bit shank before installing the bit.

Insert the bit into the tool. Turn the bit and push it in until it engages. (Fig. 4)

If the bit cannot be pushed in, remove the bit. Pull the chuck cover down a couple of times. Then insert the bit again. Turn the bit and push it in until it engages.

After installing, always make sure that the bit is securely held in place by trying to pull it out.

To remove the bit, pull the chuck cover down all the way and pull the bit out. (Fig. 5)

Bit angle (Fig. 6 & 7)

The bit can be secured at 12 different angles. To change the bit angle, slide the change ring forward, then turn the change ring to change the bit angle. At the desired angle, slide the change ring back to the original position. The bit will be secured in place.

Hook (Fig. 8)

When connecting the power supply cord to an extension cord, use the hook so that the plug of power supply cord cannot be disconnected from the connector of extension cord. Set it on the extension cord 10 cm - 20 cm away from the connector of the extension cord.

OPERATION (Fig. 9)

Position the bit at the location to be chipped, then pull the switch trigger. Apply slight pressure on the tool so that the tool will not bounce around, uncontrolled.

Pressing very hard on the tool will not increase the efficiency. (Fig. 10)

NOTE:

- When removing tiles with a scaling chisel, apply the chisel to the bottom of tiles as shown in the figure. If you operate the tool with the chisel applied to the top surface of tiles, the service life of the chisel will be shortened.

MAINTENANCE

CAUTION:

- Always be sure that the tool is switched off and unplugged before attempting to perform inspection or maintenance.
 - Never use gasoline, benzine, thinner, alcohol or the like. Discoloration, deformation or cracks may result.
- To maintain product SAFETY and RELIABILITY, repairs, carbon brush inspection and replacement, any other maintenance or adjustment should be performed by Makita Authorized Service Centers, always using Makita replacement parts.

OPTIONAL ACCESSORIES

CAUTION:

- These accessories or attachments are recommended for use with your Makita tool specified in this manual. The use of any other accessories or attachments might present a risk of injury to persons. Only use accessory or attachment for its stated purpose.

If you need any assistance for more details regarding these accessories, ask your local Makita Service Center.

- Bull point
- Cold chisel
- Scaling chisel
- Bit grease
- Safety goggles
- Hammer grease
- Hook

NOTE:

- Some items in the list may be included in the tool package as standard accessories. They may differ from country to country.

Noise ENG905-1
The typical A-weighted noise level determined according to EN62841-2-6:

Sound pressure level (L_{pA}): 77 dB (A)

Uncertainty (K): 2.73 dB (A)

The noise level under working may exceed 80 dB (A).

- ENG907-1
- The declared noise emission value(s) has been measured in accordance with a standard test method and may be used for comparing one tool with another.
 - The declared noise emission value(s) may also be used in a preliminary assessment of exposure.

⚠ WARNING:

- **Wear ear protection.**
- **The noise emission during actual use of the power tool can differ from the declared value(s) depending on the ways in which the tool is used especially what kind of workpiece is processed.**
- **Be sure to identify safety measures to protect the operator that are based on an estimation of exposure in the actual conditions of use (taking account of all parts of the operating cycle such as the times when the tool is switched off and when it is running idle in addition to the trigger time).**

Vibration ENG900-1
The vibration total value (tri-axial vector sum) determined according to EN62841-2-6:

Work mode: chiseling

Vibration emission ($a_{h,CHeq}$): 18.0 m/s²

Uncertainty (K): 1.5 m/s²

- ENG901-2
- The declared vibration total value(s) has been measured in accordance with a standard test method and may be used for comparing one tool with another.
 - The declared vibration total value(s) may also be used in a preliminary assessment of exposure.

⚠ WARNING:

- **The vibration emission during actual use of the power tool can differ from the declared value(s) depending on the ways in which the tool is used especially what kind of workpiece is processed.**
- **Be sure to identify safety measures to protect the operator that are based on an estimation of exposure in the actual conditions of use (taking account of all parts of the operating cycle such as the times when the tool is switched off and when it is running idle in addition to the trigger time).**

EC Declaration of Conformity
For European countries only

The EC declaration of conformity is included as Annex A to this instruction manual.