

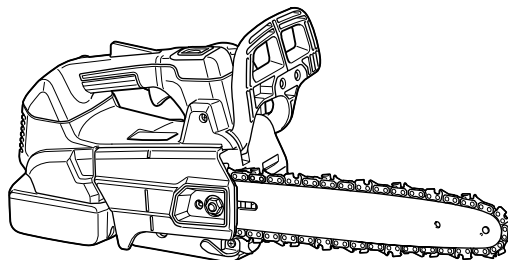

EN	Cordless Chain Saw	INSTRUCTION MANUAL	7
FR	Tronçonneuse sans Fil	MANUEL D'INSTRUCTIONS	20
DE	Akku-Kettensäge	BETRIEBSANLEITUNG	34
IT	Motosega a batteria	ISTRUZIONI PER L'USO	48
NL	Accukettingzaag	GEbruIKSAANWIJZING	62
ES	Electrosierra Inalámbrica	MANUAL DE INSTRUCCIONES	76
PT	Motosserra a Bateria	MANUAL DE INSTRUÇÕES	90
DA	Akku-kædesav	BRUGSANVISNING	104
EL	Φορητό αλυσοπρίονο	ΕΓΧΕΙΡΙΔΙΟ ΟΔΗΓΙΩΝ	117
TR	Akülü Ağaç Kesme	KULLANMA KILAVUZU	133

DUC256
DUC306
DUC356
DUC406
DUC256C



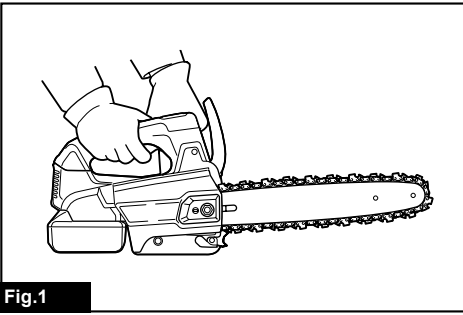

Fig.1

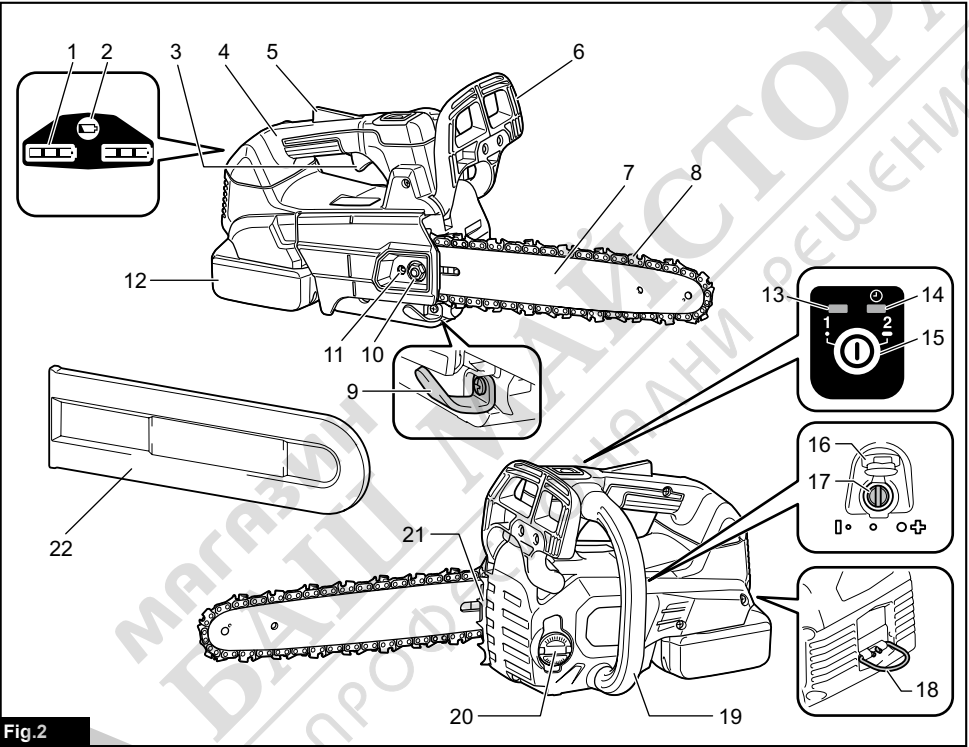

Fig.2

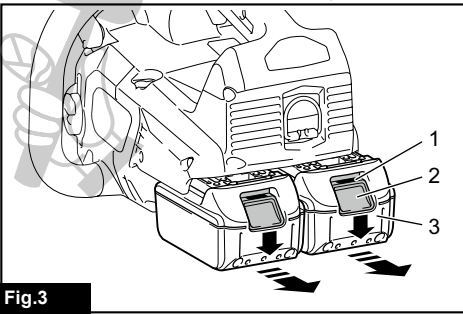

Fig.3

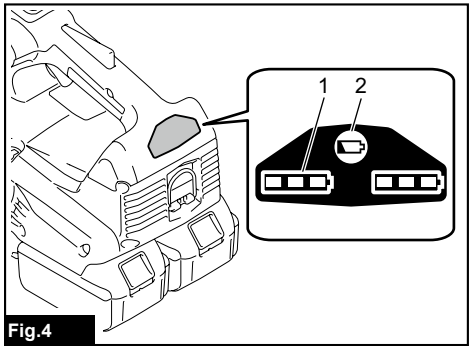

Fig.4

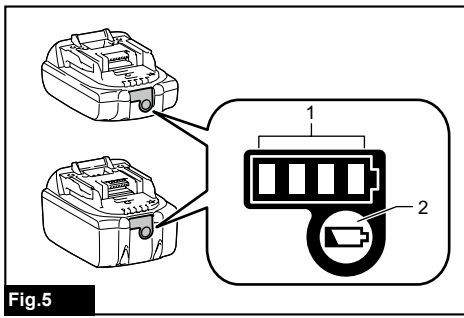

Fig.5

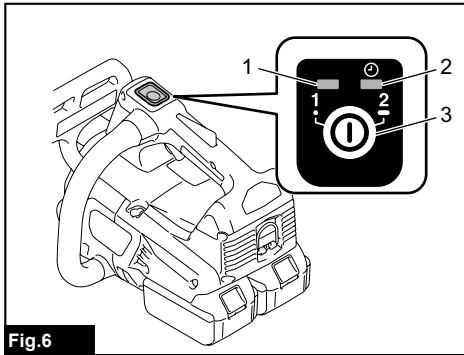

Fig.6

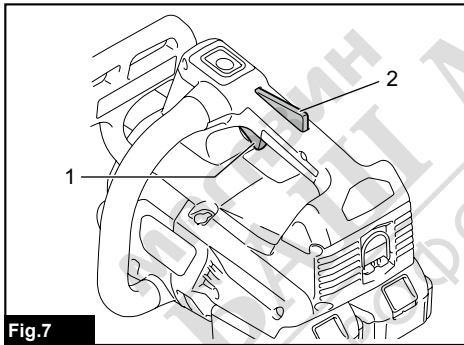

Fig.7

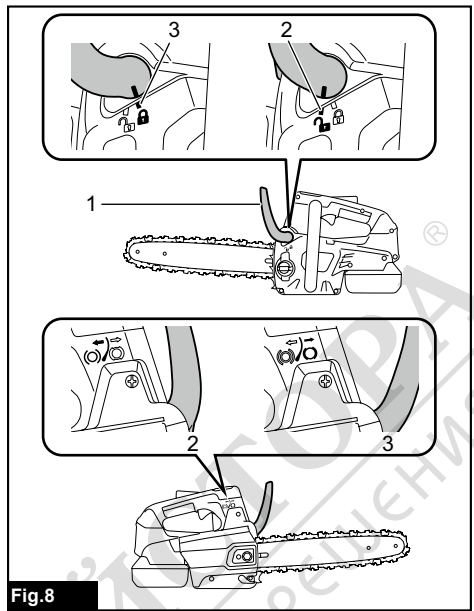

Fig.8

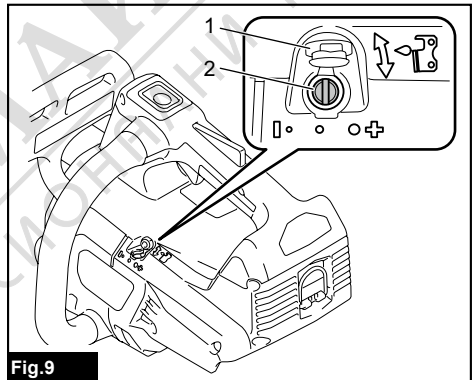

Fig.9

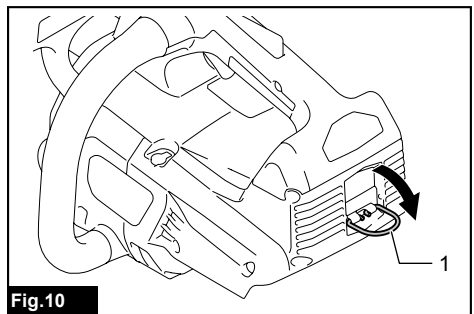

Fig.10



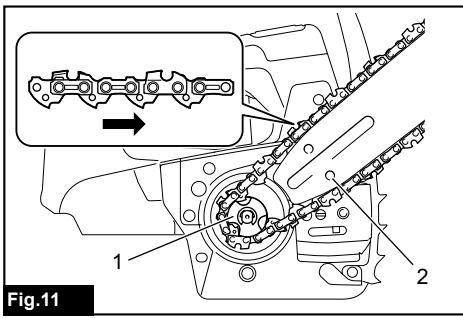

Fig.11

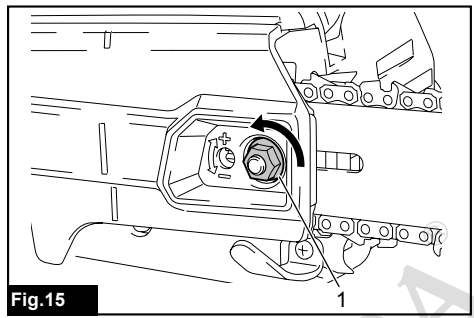

Fig.15

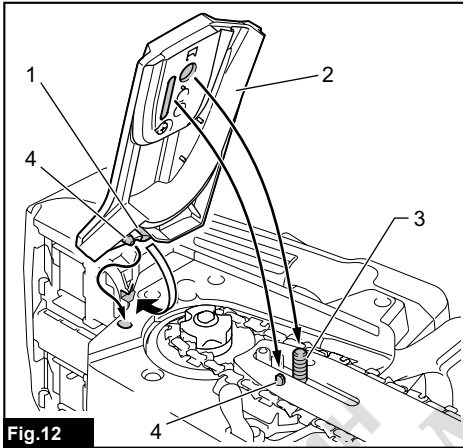

Fig.12

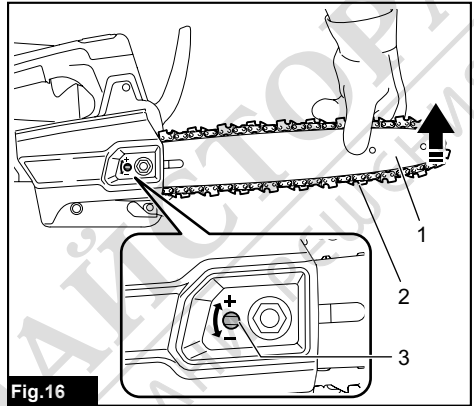

Fig.16

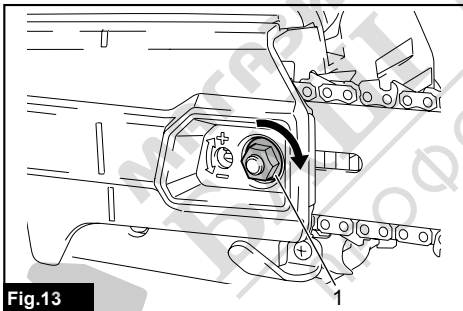

Fig.13

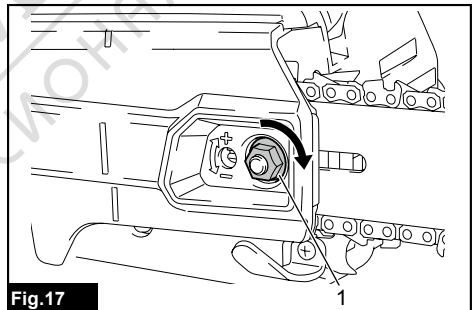

Fig.17

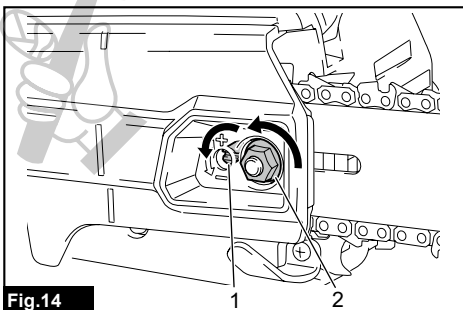

Fig.14

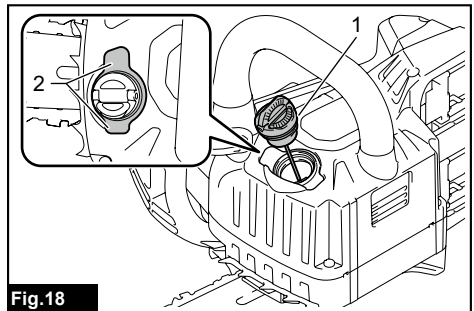

Fig.18

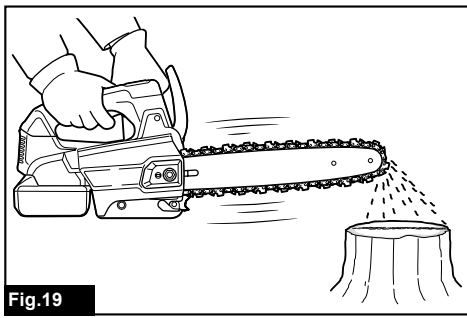

Fig.19

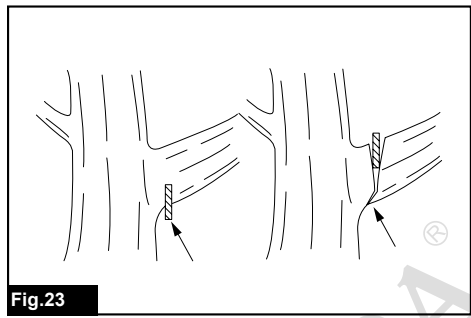

Fig.23

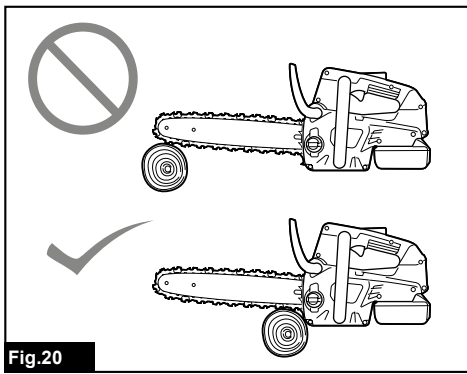

Fig.20

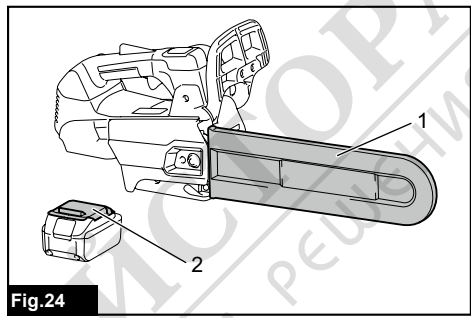

Fig.24

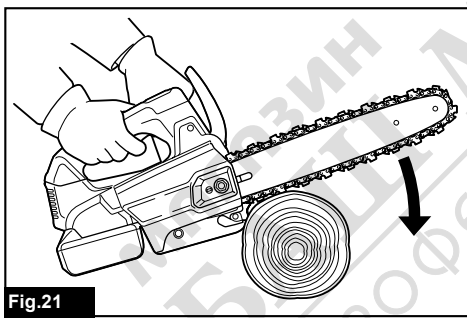

Fig.21

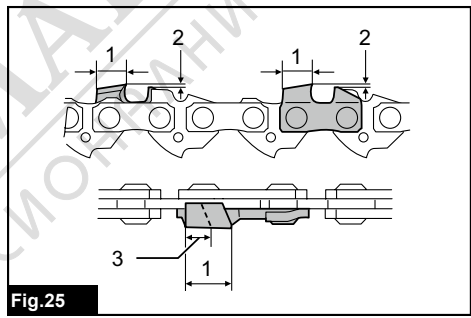

Fig.25

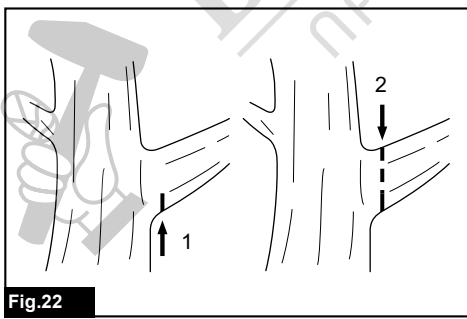

Fig.22

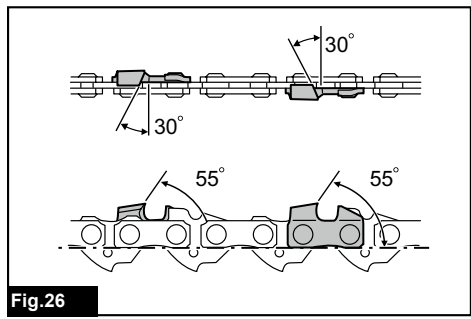

Fig.26

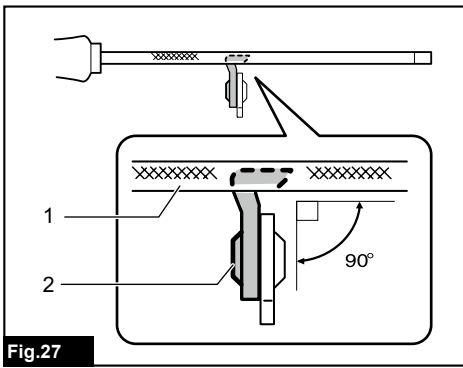

Fig.27

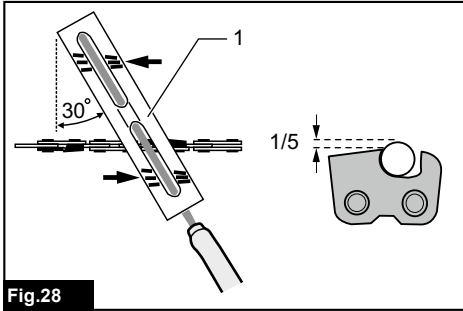

Fig.28

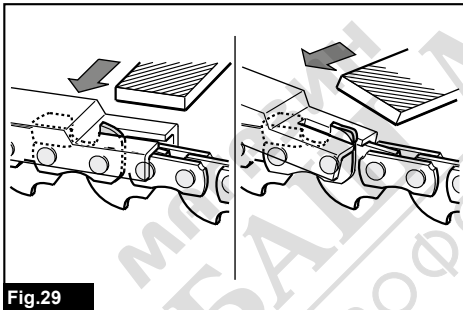

Fig.29

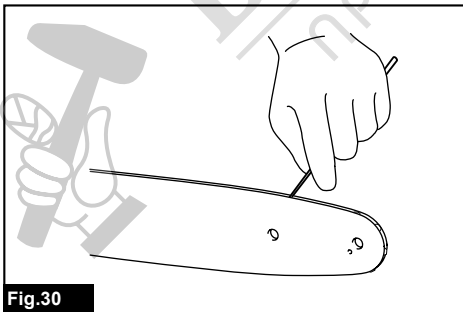

Fig.30

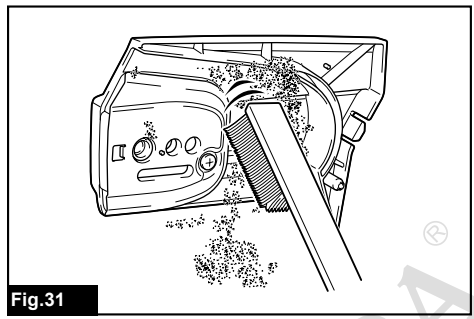

Fig.31

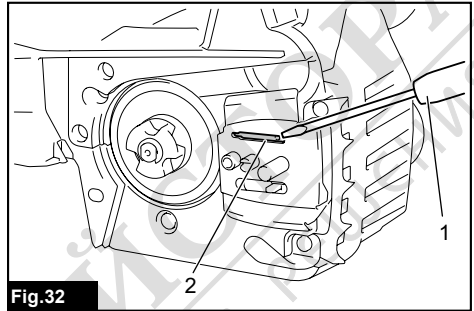

Fig.32

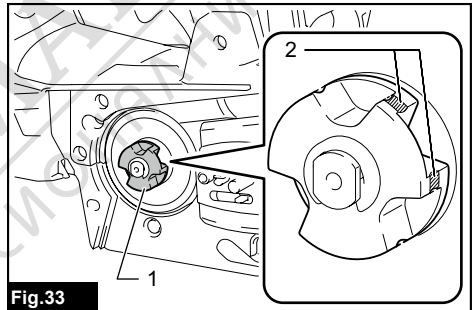

Fig.33

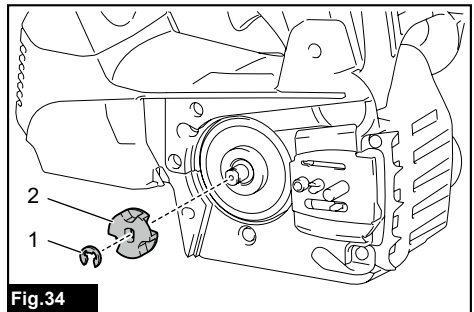

Fig.34

SPECIFICATIONS

Model:		DUC256	DUC306	DUC356	DUC406	DUC256C
Overall length (without guide bar)		270 mm				
Rated voltage		D.C. 36 V				
Net weight	*1	2.8 kg				
	*2	4.6 - 4.8 kg	4.7 - 4.9 kg	4.8 - 5.0 kg	4.8 - 5.1 kg	4.6 - 4.7 kg
Standard guide bar length		250 mm	300 mm	350 mm	400 mm	250 mm
Recommended guide bar length	with 90PX	250 - 400 mm				-
	with 91PX	250 - 400 mm				-
	with 25AP					250 mm
Applicable saw chain type (refer to the table below)				90PX 91PX	25AP	
Standard sprocket	Number of teeth	6				9
	Pitch	3/8"				1/4"
Chain speed		0 - 20 m/s (0 - 1,200 m/min)				
Chain oil tank volume		200 cm ³				

- Due to our continuing program of research and development, the specifications herein are subject to change without notice.

- Specifications may differ from country to country.

*1: Weight, without the saw chain, guide bar, guide bar cover, oil and battery cartridge(s).

*2: The lightest and heaviest combination of weight, according to EPTA-Procedure 01/2014. The weight may differ depending on the attachment(s), including the battery cartridge(s).

Applicable battery cartridge and charger

Battery cartridge	BL1830B / BL1840B / BL1850B / BL1860B
Charger	DC18RC / DC18RD / DC18RE / DC18SD / DC18SE / DC18SF / DC18SH

- Some of the battery cartridges and chargers listed above may not be available depending on your region of residence.

⚠WARNING: Only use the battery cartridges and chargers listed above. Use of any other battery cartridges and chargers may cause injury and/or fire.

Recommended cord connected power source

Battery adapter	BAP182
-----------------	--------

- The cord connected power source(s) listed above may not be available depending on your region of residence.
- Before using the cord connected power source, read instruction and cautionary markings on them.

Saw chain, guide bar, and sprocket combination

Saw chain type		90PX			
Number of drive links		40	46	52	56
Guide bar	Guide bar length	250 mm	300 mm	350 mm	400 mm
	Cutting length	238 mm	294 mm	350 mm	387 mm
	Pitch	3/8"			
	Gauge	1.1 mm			
	Type	Sprocket nose bar			
Sprocket	Number of teeth	6			
	Pitch	3/8"			











Saw chain type		91PX			
Number of drive links		40	46	52	56
Guide bar	Guide bar length	250 mm	300 mm	350 mm	400 mm
	Cutting length	238 mm	294 mm	350 mm	387 mm
	Pitch	3/8"			
	Gauge	1.3 mm			
	Type	Sprocket nose bar			
Sprocket	Number of teeth	6			
	Pitch	3/8"			

Saw chain type		25AP			
Number of drive links		60			
Guide bar	Guide bar length	250 mm			
	Cutting length	253 mm			
	Pitch	1/4"			
	Gauge	1.3 mm			
	Type	Carving bar			
Sprocket	Number of teeth	9			
	Pitch	1/4"			

⚠ WARNING: Use appropriate combination of the guide bar and saw chain. Otherwise personal injury may result.

Symbols

The followings show the symbols which may be used for the equipment. Be sure that you understand their meaning before use.

	Read instruction manual.
	Wear safety glasses.
	Wear ear protection.
	Wear a helmet, goggles and ear protection.
	Use appropriate protection for foot-leg and hand-arm.
	This saw is to be used by properly trained operators only.
	Do not expose to moisture.
	Maximum permissible cut length
	Always use two hands when operating the chain saw.
	Beware of chain saw kickback and avoid contact with bar tip.
	Direction of chain travel



Saw chain oil adjustment



Only for EU countries

Due to the presence of hazardous components in the equipment, waste electrical and electronic equipment, accumulators and batteries may have a negative impact on the environment and human health. Do not dispose of electrical and electronic appliances or batteries with household waste!

In accordance with the European Directive on waste electrical and electronic equipment and on accumulators and batteries and waste accumulators and batteries, as well as their adaptation to national law, waste electrical equipment, batteries and accumulators should be stored separately and delivered to a separate collection point for municipal waste, operating in accordance with the regulations on environmental protection.

This is indicated by the symbol of the crossed-out wheeled bin placed on the equipment.



Guaranteed sound power level according to EU Outdoor Noise Directive.



Sound power level according to Australia NSW Noise Control Regulation.

Intended use

The tool is intended for cutting branches and pruning trees. It is also suitable for tree service.

Noise

The typical A-weighted noise level determined according to EN62841-1 and EN ISO 11681-2 as applicable:

Model DUC256

Sound pressure level (L_{pA}): 95 dB(A)
Sound power level (L_{WA}): 103 dB (A)
Uncertainty (K): 3 dB(A)

Model DUC306

Sound pressure level (L_{pA}): 95 dB(A)
Sound power level (L_{WA}): 103 dB (A)
Uncertainty (K): 3 dB(A)

Model DUC356

Sound pressure level (L_{pA}): 95 dB(A)
Sound power level (L_{WA}): 103 dB (A)
Uncertainty (K): 3 dB(A)

Model DUC406

Sound pressure level (L_{pA}): 95 dB(A)
Sound power level (L_{WA}): 103 dB (A)
Uncertainty (K): 3 dB(A)

Model DUC256C

Sound pressure level (L_{pA}): 95 dB(A)
Sound power level (L_{WA}): 103 dB (A)
Uncertainty (K): 3 dB(A)

NOTE: The declared noise emission value(s) has been measured in accordance with a standard test method and may be used for comparing one tool with another.

NOTE: The declared noise emission value(s) may also be used in a preliminary assessment of exposure.

⚠WARNING: Wear ear protection.

⚠WARNING: The noise emission during actual use of the power tool can differ from the declared value(s) depending on the ways in which the tool is used especially what kind of workpiece is processed.

⚠WARNING: Be sure to identify safety measures to protect the operator that are based on an estimation of exposure in the actual conditions of use (taking account of all parts of the operating cycle such as the times when the tool is switched off and when it is running idle in addition to the trigger time).

Vibration

The vibration total value (tri-axial vector sum) determined according to EN62841-1 and EN ISO 11681-2 as applicable:

Model DUC256

Work mode: cutting wood
Vibration emission ($a_{h,W}$): 3.6 m/s²
Uncertainty (K): 1.5 m/s²

Model DUC306

Work mode: cutting wood
Vibration emission ($a_{h,W}$): 3.6 m/s²
Uncertainty (K): 1.5 m/s²

Model DUC356

Work mode: cutting wood
Vibration emission ($a_{h,W}$): 3.6 m/s²
Uncertainty (K): 1.5 m/s²

Model DUC406

Work mode: cutting wood
Vibration emission ($a_{h,W}$): 3.6 m/s²
Uncertainty (K): 1.5 m/s²

Model DUC256C

Work mode: cutting wood
Vibration emission ($a_{h,W}$): 2.8 m/s²
Uncertainty (K): 1.5 m/s²

NOTE: The declared vibration total value(s) has been measured in accordance with a standard test method and may be used for comparing one tool with another.

NOTE: The declared vibration total value(s) may also be used in a preliminary assessment of exposure.

⚠WARNING: The vibration emission during actual use of the power tool can differ from the declared value(s) depending on the ways in which the tool is used especially what kind of workpiece is processed.

⚠WARNING: Be sure to identify safety measures to protect the operator that are based on an estimation of exposure in the actual conditions of use (taking account of all parts of the operating cycle such as the times when the tool is switched off and when it is running idle in addition to the trigger time).

EC Declaration of Conformity

For European countries only

The EC declaration of conformity is included as Annex A to this instruction manual.

SAFETY WARNINGS

General power tool safety warnings

⚠WARNING: Read all safety warnings, instructions, illustrations and specifications provided with this power tool. Failure to follow all instructions listed below may result in electric shock, fire and/or serious injury.

Save all warnings and instructions for future reference.

The term "power tool" in the warnings refers to your mains-operated (corded) power tool or battery-operated (cordless) power tool.

Cordless Chain saw safety warnings

1. **Keep all parts of the body away from the saw chain when the chain saw is operating. Before you start the chain saw, make sure the saw chain is not contacting anything.** A moment of inattention while operating chain saws may cause entanglement of your clothing or body with the saw chain.
2. **Always hold the chain saw with your right hand on the top handle and your left hand on the front handle.** Holding the chain saw with a reversed hand configuration increases the risk of personal injury and should never be done.

3. **Hold the power tool by insulated gripping surfaces only, because the saw chain may contact hidden wiring.** Saw chains contacting a "live" wire may make exposed metal parts of the power tool "live" and could give the operator an electric shock.
 4. **Wear safety glasses and hearing protection.** Further protective equipment for head, hands, legs and feet is recommended. Adequate protective clothing will reduce personal injury by flying debris or accidental contact with the saw chain.
 5. **Always keep proper footing.**
 6. **When cutting a limb that is under tension be alert for spring back.** When the tension in the wood fibres is released the spring loaded limb may strike the operator and/or throw the chain saw out of control.
 7. **Use extreme caution when cutting brush and saplings.** The slender material may catch the saw chain and be whipped toward you or pull you off balance.
 8. **Carry the chain saw by the front handle with the chain saw switched off and away from your body. When transporting or storing the chain saw always fit the guide bar cover.** Proper handling of the chain saw will reduce the likelihood of accidental contact with the moving saw chain.
 9. **Follow instructions for lubricating, chain tensioning and changing accessories.** Improperly tensioned or lubricated chain may either break or increase the chance for kickback.
 10. **Keep handles dry, clean, and free from oil and grease.** Greasy, oily handles are slippery causing loss of control.
 11. **Cut wood only. Do not use chain saw for purposes not intended.** For example: do not use chain saw for cutting plastic, masonry or non-wood building materials. Use of the chain saw for operations different than intended could result in a hazardous situation.
 12. **Causes and operator prevention of kickback:** Kickback may occur when the nose or tip of the guide bar touches an object, or when the wood closes in and pinches the saw chain in the cut. Tip contact in some cases may cause a sudden reverse reaction, kicking the guide bar up and back towards the operator. Pinching the saw chain along the top of the guide bar may push the guide bar rapidly back towards the operator. Either of these reactions may cause you to lose control of the saw which could result in serious personal injury. Do not rely exclusively upon the safety devices built into your saw. As a chain saw user, you should take several steps to keep your cutting jobs free from accident or injury. Kickback is the result of tool misuse and/or incorrect operating procedures or conditions and can be avoided by taking proper precautions as given below:
 - Maintain a firm grip, with thumbs and fingers encircling the chain saw handles, with both hands on the saw and position your body and arm to allow you to resist kickback forces. Kickback forces can be controlled by the operator, if proper precautions are taken. Do not let go of the chain saw.
 - Do not overreach and do not cut above shoulder height. This helps prevent unintended tip contact and enables better control of the chain saw in unexpected situations.
 - Only use replacement bars and chains specified by the manufacturer. Incorrect replacement bars and chains may cause chain breakage and/or kickback.
 - Follow the manufacturer's sharpening and maintenance instructions for the saw chain. Decreasing the depth gauge height can lead to increased kickback.
 13. **Before starting work, check that the chain saw is in proper working order and that its condition complies with the safety regulations. Check in particular that:**
 - The chain brake is working properly;
 - The run-down brake is working properly;
 - The bar and the sprocket cover are fitted correctly;
 - The chain has been sharpened and tensioned in accordance with the regulations.
 14. **Do not start the chain saw with the chain cover being installed on it.** Starting the chain saw with the chain cover being installed on it may cause the chain cover to thrown out forward resulting in personal injury and damage to objects around the operator.
- Additional Safety Warnings:**
1. **When using the tool with battery adapter, be careful not to trip over the cord during operation.**
 2. **When using the tool with battery adapter, keep the cord away from obstacles such as a work-piece and branches during operation.** The cord caught by obstacles may cause serious injury.
- Top handle chainsaw specific safety warnings**
1. **This chain saw is designed especially for tree care and surgery. The chain saw is intended to be used by properly trained persons only. Observe all instructions, procedures and recommendations from the relevant professional organization. Otherwise fatal accidents may occur. It is recommend that always using a rising platform (cherry picker, lift) for sawing in trees. Rappelling techniques are extremely dangerous and require special training. The operators must be trained to become familiar with safety equipment usage and climbing techniques. Always use the appropriate belts, ropes and carabiners when working in trees. Always use restraining equipment for both the operator and the saw.**
 2. **Perform cleaning and maintenance before storage in accordance with the instruction manual.**
 3. **Ensure safe positioning of the chain saw during car transportation to avoid fuel or chain oil leakage, damage to the tool and personal injury.**
 4. **Regularly check the functionality of chain brake.**

5. **Do not fill the chain oil near fire. Never smoke when you fill the chain oil.**
6. **National regulation may restrict the use of the chain saw.**
7. **If the equipment gets heavy impact or fall, check the condition before continuing work. Check the controls and safety devices for malfunction. If there is any damage or doubt, ask our authorized service center for the inspection and repair.**
8. **Always activate the chain brake before starting the chain saw.**
9. **Hold the saw firmly in place to avoid skating (skid movement) or bouncing of the saw when starting a cut.**
10. **At the end of the cut, be careful to keep your balance due to the "drop".**
11. **Take into account the direction and speed of the wind. Avoid sawdust and chain oil mist.**

Protective equipment

1. **In order to avoid head, eye, hand or foot injuries as well as to protect your hearing the following protective equipment must be used during operation of the chain saw:**
 - The kind of clothing should be appropriate, i. e. it should be tight-fitting but not be a hindrance. Do not wear jewelry or clothing which could become entangled with bushes or shrubs. If you have long hair, always wear a hairnet!
 - It is necessary to wear a protective helmet whenever working with the chain saw. The **protective helmet** is to be checked in regular intervals for damage and is to be replaced after 5 years at the latest. Use only approved protective helmets.
 - The **face shield** of the protective helmet (or the goggles) protects against sawdust and wood chips. During operation of the chain saw always wear a goggle or a face shield to prevent eye injuries.
 - Wear adequate **noise protection equipment** (ear muffs, ear plugs, etc.)
 - The **protective jacket** consists of 22 layers of nylon and protects the operator against cuts. It is always to be worn when working from elevated platforms (cherry pickers, lifts), from platforms mounted on ladders or when climbing with ropes.
 - The **protective brace and bib overall** is made of a nylon fabric with 22 layers and protects against cuts. We strongly recommend its use.
 - **Protective gloves** made of thick leather are part of the prescribed equipment and must always be worn during operation of the chain saw.
 - During operation of the chain saw **safety shoes** or **safety boots** fitted with anti skid sole, steel toe caps and protection for the leg must always be worn. Safety shoes equipped with a protective layer provide protection against cuts and ensure a secure footing. For working in trees the safety boots must be suitable for climbing techniques.

Vibration

1. Individuals with poor circulation who are exposed to excessive vibration may experience injury to blood vessels or the nervous system. Vibration may cause the following symptoms to occur in the fingers, hands or wrists: "Falling asleep" (numbness), tingling, pain, stabbing sensation, alteration of skin colour or of the skin. **If any of these symptoms occur, see a physician!** To reduce the risk of "white finger disease", keep your hands warm during operation and well maintain the equipment and accessories.

SAVE THESE INSTRUCTIONS.

▲WARNING: DO NOT let comfort or familiarity with product (gained from repeated use) replace strict adherence to safety rules for the subject product. **MISUSE** or failure to follow the safety rules stated in this instruction manual may cause serious personal injury.

Important safety instructions for battery cartridge

1. **Before using battery cartridge, read all instructions and cautionary markings on (1) battery charger, (2) battery, and (3) product using battery.**
2. **Do not disassemble or tamper with the battery cartridge.** It may result in a fire, excessive heat, or explosion.
3. **If operating time has become excessively shorter, stop operating immediately. It may result in a risk of overheating, possible burns and even an explosion.**
4. **If electrolyte gets into your eyes, rinse them out with clear water and seek medical attention right away. It may result in loss of your eyesight.**
5. **Do not short the battery cartridge:**
 - (1) **Do not touch the terminals with any conductive material.**
 - (2) **Avoid storing battery cartridge in a container with other metal objects such as nails, coins, etc.**
 - (3) **Do not expose battery cartridge to water or rain.**

A battery short can cause a large current flow, overheating, possible burns and even a breakdown.
6. **Do not store and use the tool and battery cartridge in locations where the temperature may reach or exceed 50 °C (122 °F).**
7. **Do not incinerate the battery cartridge even if it is severely damaged or is completely worn out. The battery cartridge can explode in a fire.**
8. **Do not nail, cut, crush, throw, drop the battery cartridge, or hit against a hard object to the battery cartridge.** Such conduct may result in a fire, excessive heat, or explosion.
9. **Do not use a damaged battery.**

10. **The contained lithium-ion batteries are subject to the Dangerous Goods Legislation requirements.**

For commercial transports e.g. by third parties, forwarding agents, special requirement on packaging and labeling must be observed. For preparation of the item being shipped, consulting an expert for hazardous material is required. Please also observe possibly more detailed national regulations.

Tape or mask off open contacts and pack up the battery in such a manner that it cannot move around in the packaging.

11. **When disposing the battery cartridge, remove it from the tool and dispose of it in a safe place. Follow your local regulations relating to disposal of battery.**
12. **Use the batteries only with the products specified by Makita.** Installing the batteries to non-compliant products may result in a fire, excessive heat, explosion, or leak of electrolyte.
13. **If the tool is not used for a long period of time, the battery must be removed from the tool.**
14. **During and after use, the battery cartridge may take on heat which can cause burns or low temperature burns. Pay attention to the handling of hot battery cartridges.**
15. **Do not touch the terminal of the tool immediately after use as it may get hot enough to cause burns.**
16. **Do not allow chips, dust, or soil stuck into the terminals, holes, and grooves of the battery cartridge.** It may cause heating, catching fire, burst and malfunction of the tool or battery cartridge, resulting in burns or personal injury.

17. **Unless the tool supports the use near high-voltage electrical power lines, do not use the battery cartridge near high-voltage electrical power lines.** It may result in a malfunction or breakdown of the tool or battery cartridge.
18. **Keep the battery away from children.**

SAVE THESE INSTRUCTIONS.

⚠CAUTION: Only use genuine Makita batteries. Use of non-genuine Makita batteries, or batteries that have been altered, may result in the battery bursting causing fires, personal injury and damage. It will also void the Makita warranty for the Makita tool and charger.

Tips for maintaining maximum battery life

1. **Charge the battery cartridge before completely discharged. Always stop tool operation and charge the battery cartridge when you notice less tool power.**
2. **Never recharge a fully charged battery cartridge. Overcharging shortens the battery service life.**
3. **Charge the battery cartridge with room temperature at 10 °C - 40 °C (50 °F - 104 °F). Let a hot battery cartridge cool down before charging it.**
4. **When not using the battery cartridge, remove it from the tool or the charger.**
5. **Charge the battery cartridge if you do not use it for a long period (more than six months).**

PARTS DESCRIPTION

► Fig.2

1	Battery indicator	2	Check button	3	Switch trigger
4	Top handle	5	Lock-off lever	6	Front hand guard
7	Guide bar	8	Saw chain	9	Chain catcher
10	Retaining nut	11	Chain adjusting screw	12	Battery cartridge
13	Main power lamp	14	Mode indicator	15	Main power switch
16	Cap	17	Adjusting screw (for oil pump)	18	Carabiner
19	Front handle	20	Oil tank cap	21	Spike bumper
22	Guide bar cover	-	-	-	-

FUNCTIONAL DESCRIPTION

CAUTION: Always be sure that the tool is switched off and the battery cartridge is removed before adjusting or checking function on the tool.

Installing or removing battery cartridge

CAUTION: Always switch off the tool before installing or removing of the battery cartridge.

CAUTION: Hold the tool and the battery cartridge firmly when installing or removing battery cartridge. Failure to hold the tool and the battery cartridge firmly may cause them to slip off your hands and result in damage to the tool and battery cartridge and a personal injury.

► **Fig.3:** 1. Red indicator 2. Button 3. Battery cartridge

To remove the battery cartridge, slide it from the tool while sliding the button on the front of the cartridge.

To install the battery cartridge, align the tongue on the battery cartridge with the groove in the housing and slip it into place. Insert it all the way until it locks in place with a little click. If you can see the red indicator as shown in the figure, it is not locked completely.

CAUTION: Always install the battery cartridge fully until the red indicator cannot be seen. If not, it may accidentally fall out of the tool, causing injury to you or someone around you.

CAUTION: Do not install the battery cartridge forcibly. If the cartridge does not slide in easily, it is not being inserted correctly.

Indicating the remaining battery capacity

► **Fig.4:** 1. Battery indicator 2. Check button

Press the check button to indicate the remaining battery capacities. The battery indicators correspond to each battery.

Battery indicator status			Remaining battery capacity
On	Off	Blinking	
			50% to 100%
			20% to 50%
			0% to 20%
			Charge the battery

Indicating the remaining battery capacity

Only for battery cartridges with the indicator

► **Fig.5:** 1. Indicator lamps 2. Check button

Press the check button on the battery cartridge to indicate the remaining battery capacity. The indicator lamps light up for a few seconds.

Indicator lamps			Remaining capacity
Lighted	Off	Blinking	
			75% to 100%
			50% to 75%
			25% to 50%
			0% to 25%
			Charge the battery.
			The battery may have malfunctioned.

NOTE: Depending on the conditions of use and the ambient temperature, the indication may differ slightly from the actual capacity.

NOTE: The first (far left) indicator lamp will blink when the battery protection system works.

Tool / battery protection system

The tool is equipped with a tool/battery protection system. This system automatically cuts off power to the motor to extend tool and battery life. The tool will automatically stop during operation if the tool or battery is placed under one of the following conditions:

Overload protection

When the battery is operated in a manner that causes it to draw an abnormally high current, the tool automatically stops and the main power lamp blinks in green. In this situation, turn the tool off and stop the application that caused the tool to become overloaded. Then turn the tool on to restart.

Overheat protection

When the tool or battery is overheated, the tool stops automatically and the main power lamp lights up in red. In this case, let the tool and battery cool before turning the tool on again.

NOTE: In high temperature environment, the overheat protection likely to work and the tool stops automatically.

Overdischarge protection

When the battery capacity is not enough, the tool stops automatically and the main power lamp blinks in red. In this case, remove the battery from the tool and charge the battery.

Main power switch

⚠ WARNING: Always turn off the main power switch when not in use.

To turn on the tool, press the main power switch until the main power lamp lights up in green. To turn off, press the main power switch again.

- **Fig. 6:** 1. Main power lamp 2. Mode indicator
3. Main power switch

NOTE: The main power lamp blinks in green if the switch trigger is pulled under unoperable conditions. The lamp blinks in one of the following conditions.

- When you turn on the main power switch while holding down the lock-off lever and the switch trigger.
- When you pull the switch trigger while the chain brake is applied.
- When you release the chain brake while holding down the lock-off lever and pulling the switch trigger.

NOTE: This tool employs the auto power-off function. To avoid unintentional start up, the main power switch will automatically shut down when the switch trigger is not pulled for a certain period after the main power switch is turned on.

You can use the tool in the Torque Boost mode for cutting thick branches or hard branches. To use the tool in the Torque Boost mode, when the tool is turned off, press the main power switch for a few seconds until the mode indicator lights up in green.

NOTE: You can use the tool in the Torque Boost mode up to 60 seconds. Depending on the usage conditions, this mode shifts to the normal mode in less than 60 seconds.

NOTE: If the mode indicator blinks in green when you press the main power switch for a few seconds, the Torque Boost mode is not available. In this case, follow the steps below.

- The Torque Boost mode is not available right after the cutting operation. Wait for more than 10 seconds, and then press the main power switch for a few seconds again.
- If you use the Torque Boost mode several times, the use of the Torque Boost mode is restricted to protect the battery. If the Torque Boost mode is not available after waiting for more than 10 seconds, replace the battery cartridge with a fully charged one, or recharge the battery cartridge.

NOTE: If the main power lamp lights up in red or blinks in red or green, refer to the instructions for tool/battery protection system.

Switch action

⚠ WARNING: For your safety, this tool is equipped with lock-off lever which prevents the tool from unintended starting. NEVER use the tool if it runs when you simply pull the switch trigger without pressing the lock-off lever. Return the tool to our authorized service center for proper repairs BEFORE further usage.

⚠ WARNING: NEVER tape down or defeat purpose and function of lock-off lever.

⚠ CAUTION: Before installing the battery cartridge into the tool, always check to see that the switch trigger actuates properly and returns to the "OFF" position when released.

NOTICE: Do not pull the switch trigger hard without pressing the lock-off lever. This can cause switch breakage.

To prevent the switch trigger from being accidentally pulled, a lock-off lever is provided. To start the tool, depress the lock-off lever and pull the switch trigger. The tool speed increases by increasing pressure on the switch trigger. Release the switch trigger to stop.

- **Fig. 7:** 1. Switch trigger 2. Lock-off lever

Checking the chain brake

⚠ CAUTION: Hold the chain saw with both hands when switching it on. Hold the top handle with your right hand, the front handle with your left. The bar and the chain must not be in contact with any object.

⚠ CAUTION: Should the saw chain not stop immediately when this test is performed, the saw may not be used under any circumstances. Consult our authorized service center.

1. Press the lock-off lever, then pull the switch trigger. The saw chain starts immediately.
2. Push the front hand guard forwards with the back of your hand. Make sure that the chain saw comes to an immediate standstill.

- **Fig. 8:** 1. Front hand guard 2. Unlocked position
3. Locked position

Checking the run-down brake

⚠ CAUTION: If the saw chain does not stop within two seconds in this test, stop using the chain saw and consult our authorized service center.

Run the chain saw then release the switch trigger completely. The saw chain must come to a standstill within two seconds.

Adjusting the chain lubrication

You can adjust the oil pump feed rate with the adjusting screw using the universal wrench. The amount of oil can be adjusted in 3 steps. Open the cap to adjust the adjusting screw.

- **Fig. 9:** 1. Cap 2. Adjusting screw

Carabiner (rope attachment point)

You can hang the tool by attaching the rope to the carabiner. Pull up the carabiner, and then tie it with the rope.

► **Fig.10:** 1. Carabiner

Spike bumper

The tool is equipped with the spike bumper as standard. For replacement of the spike bumper, ask Makita Authorized Service Centers.

When you perform the cutting operation, engage the spike bumper with the trunk and use it as a lever.

Electronic function

The tool is equipped with the electronic functions for easy operation.

- Constant speed control
The speed control function provides the constant rotation speed regardless of load conditions.

ASSEMBLY

▲CAUTION: Always be sure that the tool is switched off and the battery cartridge is removed before carrying out any work on the tool.

▲CAUTION: Do not touch the saw chain with bare hands. Always wear gloves when handling the saw chain.

Removing or installing saw chain

▲CAUTION: The saw chain and the guide bar are still hot just after the operation. Let them cool down enough before carrying out any work on the tool.

▲CAUTION: Carry out the procedure of installing or removing saw chain in a clean place free from sawdust and the like.

To install the saw chain, perform the following steps:

1. Check the direction of the saw chain. Match the direction of the saw chain with that of the mark on the chain saw body.
2. Fit one end of the saw chain on the top of the guide bar.
3. Fit the other end of the saw chain around the sprocket, then attach the guide bar to the chain saw body, aligning the hole on the guide bar with the pin on the chain saw body.

► **Fig.11:** 1. Sprocket 2. Hole

4. Insert the protrusion and the pin on the sprocket cover to the chain saw body, and then close the cover so that the bolt and pin on the chain saw body meet their counterparts on the cover.

► **Fig.12:** 1. Protrusion 2. Sprocket cover 3. Bolt 4. Pin

5. Tighten the retaining nut to secure the sprocket cover, then loosen it a bit for tension adjustment.

(See the chapter on "Adjusting saw chain tension" for procedure.)

► **Fig.13:** 1. Retaining nut

To remove the saw chain, perform the following steps:

1. Release the chain brake by pulling the front hand guard.

2. Loosen the chain adjusting screw, then the retaining nut.

► **Fig.14:** 1. Chain adjusting screw 2. Retaining nut

3. Remove the sprocket cover then remove the saw chain and guide bar from the chain saw body.

Adjusting saw chain tension

▲CAUTION: Do not tighten the saw chain too much. Excessively high tension of saw chain may cause breakage of saw chain and wear of the guide bar.

▲CAUTION: A chain which is too loose can jump off the bar and it may cause an injury accident.

The saw chain may become loose after many hours of use. From time to time check the saw chain tension before use.

1. Release the chain brake by pulling the front hand guard.

2. Loosen the retaining nut a bit to loosen the sprocket cover lightly.

► **Fig.15:** 1. Retaining nut

3. Lift up the guide bar tip slightly and adjust the chain tension. Turn the chain adjusting screw clockwise to tighten, turn it counterclockwise to loosen.

For chain blade 90PX and 91PX:

Tighten the saw chain until the lower side of the saw chain fits in the guide bar rail as illustrated.

► **Fig.16:** 1. Guide bar 2. Saw chain 3. Chain adjusting screw

For chain blade 25AP:

Tighten the saw chain so that the gap between the center of the lower side of the guide bar and the saw chain becomes approximately 1 mm to 2 mm.

4. Keep holding the guide bar lightly and tighten the sprocket cover.

For chain blade 90PX and 91PX:

Make sure that the saw chain does not loose at the lower side.

For chain blade 25AP:

Make sure that the gap between the center of the lower side of the guide bar and the saw chain is approximately 1 mm to 2 mm.

5. Tighten the retaining nut to secure the sprocket cover.

► **Fig.17:** 1. Retaining nut

OPERATION

Lubrication

Saw chain is automatically lubricated when the tool is in operation. Check the amount of remaining oil in the oil tank periodically through the oil inspection window. To refill the tank, lay the chain saw on its side, then push the oil tank cap, and then remove the oil tank cap. The proper amount of oil is 200 ml. After refilling the tank, make sure that the oil tank cap is tightened securely.

► **Fig.18:** 1. Oil tank cap 2. Oil inspection window

After refilling, hold the chain saw away from the tree. Start it and wait until lubrication on saw chain is adequate.

► **Fig.19**

NOTICE: When filling the chain oil for the first time, or refilling the tank after it has been completely emptied, add oil up to the bottom edge of the filler neck. The oil delivery may otherwise be impaired.

NOTICE: Use the saw chain oil exclusively for Makita chain saws or equivalent oil available in the market.

NOTICE: Never use oil including dust and particles or volatile oil.

NOTICE: When pruning trees, use botanical oil. Mineral oil may harm trees.

NOTICE: Before the cutting operation, make sure that the provided oil tank cap is screwed in place.

WORKING WITH THE CHAIN SAW

CAUTION: Keep all parts of the body away from the saw chain when the motor is operating.

CAUTION: Hold the chain saw firmly with both hands when the motor is running.

CAUTION: Do not overreach. Keep proper footing and balance at all times.

NOTICE: Never toss or drop the tool.

NOTICE: Do not cover the vents of the tool.

Pruning trees

Bring the chain saw body into contact with the branch to be cut before switching on. Otherwise it may cause the guide bar to wobble, resulting in injury to operator. Saw the wood to be cut by just moving it down by using the weight of the chain saw.

► **Fig.20**

If you cannot cut the timber right through with a single stroke: Apply light pressure to the handle and continue sawing and draw the chain saw back a little.

► **Fig.21**

When cutting thick branches, first make a shallow undercut and then make the finish cut from the top.

► **Fig.22**

If you try to cut off thick branches from the bottom, the branch may close in and pinch the saw chain in the cut. If you try to cut off thick branches from the top without a shallow undercut, the branch may splinter.

► **Fig.23**

Carrying tool

Before carrying the tool, always apply the chain brake and remove the battery cartridges from the tool. Then attach the guide bar cover. Also cover the battery cartridge with the battery cover.

► **Fig.24:** 1. Guide bar cover 2. Battery cover

MAINTENANCE

CAUTION: Always be sure that the tool is switched off and the battery cartridge is removed before attempting to perform inspection or maintenance.

CAUTION: Always wear gloves when performing any inspection or maintenance.

NOTICE: Never use gasoline, benzene, thinner, alcohol or the like. Discoloration, deformation or cracks may result.

To maintain product SAFETY and RELIABILITY, repairs, any other maintenance or adjustment should be performed by Makita Authorized or Factory Service Centers, always using Makita replacement parts.

Sharpening the saw chain

Sharpen the saw chain when:

- Mealy sawdust is produced when damp wood is cut;
- The chain penetrates the wood with difficulty, even when heavy pressure is applied;
- The cutting edge is obviously damaged;
- The saw pulls to the left or right in the wood. (caused by uneven sharpening of the saw chain or damage to one side only)

Sharpen the saw chain frequently but a little each time. Two or three strokes with a file are usually sufficient for routine reshaping. When the saw chain has been reshaped several times, have it sharpened in our authorized service center.

Sharpening criteria:

WARNING: An excessive distance between the cutting edge and depth gauge increases the risk of kickback.

► **Fig.25:** 1. Cutter length 2. Distance between cutting edge and depth gauge 3. Minimum cutter length (3 mm)

- All cutter length must be equal. Different cutter lengths prevent the saw chain from running smoothly and may cause the saw chain to break.
- Do not sharpen the chain when the cutter length has reached 3 mm or shorter. The chain must be replaced with new one.

- The chip thickness is determined by the distance between the depth gauge (round nose) and the cutting edge.
- The best cutting results are obtained with following distance between cutting edge and depth gauge.
 - Chain blade 90PX : 0.65 mm
 - Chain blade 91PX : 0.65 mm
 - Chain blade 25AP : 0.65 mm

► **Fig.26**

- The sharpening angle of 30° must be the same on all cutters. Different cutter angles cause the chain to run roughly and unevenly, accelerate wear, and lead to chain breaks.
- Use a suitable round file so that the proper sharpening angle is kept against the teeth.
 - Chain blade 90PX : 55°
 - Chain blade 91PX : 55°
 - Chain blade 25AP : 55°

File and file guiding

- Use a special round file (optional accessory) for saw chains to sharpen the chain. Normal round files are not suitable.
- Diameter of the round file for each saw chain is as follows:
 - Chain blade 90PX : 4.5 mm
 - Chain blade 91PX : 4.0 mm
 - Chain blade 25AP : 4.0 mm
- The file should only engage the cutter on the forward stroke. Lift the file off the cutter on the return stroke.
- Sharpen the shortest cutter first. Then the length of this shortest cutter becomes the standard for all other cutters on the saw chain.
- Guide the file as shown in the figure.

► **Fig.27:** 1. File 2. Saw chain

- The file can be guided more easily if a file holder (optional accessory) is employed. The file holder has markings for the correct sharpening angle of 30° (align the markings parallel to the saw chain) and limits the depth of penetration (to 4/5 of the file diameter).

► **Fig.28:** 1. File holder

- After sharpening the chain, check the height of the depth gauge using the chain gauge tool (optional accessory).

► **Fig.29**

- Remove any projecting material, however small, with a special flat file (optional accessory).
- Round off the front of the depth gauge again.

Cleaning the guide bar

Chips and sawdust will build up in the guide bar groove. They may clog the bar groove and impair the oil flow. Clean out the chips and sawdust every time when you sharpen or replace the saw chain.

► **Fig.30**

Cleaning the sprocket cover

Chips and saw dust will accumulate inside of the sprocket cover. Remove the sprocket cover and saw chain from the tool then clean the chips and saw dust.

► **Fig.31**

Cleaning the oil discharge hole

Small dust or particles may be built up in the oil discharge hole during operation. These dust or particles may impair the oil to flow and cause an insufficient lubrication on the whole saw chain. When a poor chain oil delivery occurs at the top of guide bar, clean the oil discharge hole as follows.

1. Remove the sprocket cover and saw chain from the tool.
2. Remove the small dust or particles using a slotted screwdriver or the like.

► **Fig.32:** 1. Slotted screwdriver 2. Oil discharge hole

3. Insert the battery cartridge into the tool. Pull the switch trigger to flow built-up dust or particles off the oil discharge hole by discharging chain oil.

4. Remove the battery cartridge from the tool. Reinstall the sprocket cover and saw chain on the tool.

Replacing the sprocket

CAUTION: A worn sprocket will damage a new saw chain. Have the sprocket replaced in this case.

Before fitting a new saw chain, check the condition of the sprocket.

- **Fig.33:** 1. Sprocket 2. Areas to be worn out
- Always fit a new locking ring when replacing the sprocket.

► **Fig.34:** 1. Locking ring 2. Sprocket

NOTICE: Make sure that the sprocket is installed as shown in the figure.

Storing the tool

1. Clean the tool before storing. Remove any chips and sawdust from the tool after removing the sprocket cover.
2. After cleaning the tool, run it under no load to lubricate the saw chain and guide bar.
3. Cover the guide bar with the guide bar cover.
4. Empty the oil tank.

Instructions for periodic maintenance

To ensure long life, prevent damage and ensure the full functioning of the safety features, the following maintenance must be performed regularly. Warranty claims can be recognized only if this work is performed regularly and properly. Failure to perform the prescribed maintenance work can lead to accidents! The user of the chain saw must not perform maintenance work which is not described in the instruction manual. All such work must be carried out by our authorized service center.

Check item / Operating time		Before operation	Everyday	Every week	Every 3 month	Annually	Before storage
Chain saw	Inspection.	✓	-	-	-	-	-
	Cleaning.	-	✓	-	-	-	-
	Check at authorized service center.	-	-	-	-	✓	✓
Saw chain	Inspection.	✓	-	-	-	-	-
	Sharpening if necessary.	-	-	-	-	-	✓
Guide bar	Inspection.	✓	✓	-	-	-	-
	Remove from the chain saw.	-	-	-	-	-	✓
Chain brake	Check the function.	✓	-	-	-	-	-
	Have it inspected regularly at authorized service center.	-	-	-	✓	-	-
Chain lubrication	Check the oil feed rate.	✓	-	-	-	-	-
Switch trigger	Inspection.	✓	-	-	-	-	-
Lock-off lever	Inspection.	✓	-	-	-	-	-
Oil tank cap	Check tightness.	✓	-	-	-	-	-
Chain catcher	Inspection.	-	-	✓	-	-	-
Screws and nuts	Inspection.	-	-	✓	-	-	-



TROUBLESHOOTING

Before asking for repairs, conduct your own inspection first. If you find a problem that is not explained in the manual, do not attempt to dismantle the tool. Instead, ask Makita Authorized Service Centers, always using Makita replacement parts for repairs.

Malfuction status	Cause	Action
The chain saw does not start.	Battery cartridge is not installed.	Install a charged battery cartridge.
	Battery problem (low voltage).	Recharge the battery cartridges. If recharging is not effective, replace the battery cartridge.
	Main power switch is off.	The chain saw is automatically turned off if it is un-operated for a certain period. Turn on the main power switch again.
The saw chain does not run.	Chain brake activated.	Release chain brake.
The motor stops running after a little use.	Battery's charge level is low.	Recharge the battery cartridges. If recharging is not effective, replace the battery cartridge.
No oil on the chain.	Oil tank is empty.	Fill the oil tank.
	Oil guide groove is dirty.	Clean the groove.
	Poor oil delivery.	Adjust the amount of oil delivery with the adjusting screw.
The chain saw does not reach maximum RPM.	Battery cartridge is installed improperly.	Install the battery cartridges as described in this manual.
	Battery power is dropping.	Recharge the battery cartridge. If recharging is not effective, replace the battery cartridge.
	The drive system does not work correctly.	Ask the authorized service center in your region for repair.
The main power lamp is blinking in green.	Switch trigger is pulled under an unoperable condition.	Pull the switch trigger after the main power switch is turned on and the chain brake is released.
Chain does not stop even the chain brake is activated: Stop the machine immediately!	The brake band is worn down.	Ask the authorized service center in your region for repair.
Abnormal vibration: Stop the machine immediately!	Loose guide bar or saw chain.	Adjust the guide bar and saw chain tension.
	Tool malfunction.	Ask the authorized service center in your region for repair.
The Torque Boost mode is not available after replacing the battery cartridge with a fully charged one.	Depending on the usage conditions, the Torque Boost mode is not available after replacing the battery cartridge.	Use the tool in the normal mode until the installed battery cartridge becomes empty, and then replace the battery cartridge with a fully charged one, or recharge the battery cartridge.
The saw chain cannot be installed.	The combination of saw chain and sprocket is not correct.	Use the correct combination of saw chain and sprocket by referring to the section for specifications.

OPTIONAL ACCESSORIES

CAUTION: These accessories or attachments are recommended for use with your Makita tool specified in this manual. The use of any other accessories or attachments might present a risk of injury to persons. Only use accessory or attachment for its stated purpose.

If you need any assistance for more details regarding these accessories, ask your local Makita Service Center.

- Saw chain
- Guide bar

- Guide bar cover
- Sprocket
- File
- Makita genuine battery and charger

WARNING: If you purchase a guide bar of different length from the standard guide bar, also purchase a suitable guide bar cover together. It must fit and fully cover the guide bar on the chain saw.

NOTE: Some items in the list may be included in the tool package as standard accessories. They may differ from country to country.