

# metabo®

PROFESSIONAL POWER TOOL SOLUTIONS

**FSP 600 HVLP**  
**FSP 600 LVLP**  
**FSP 600**  
**FSP 1000 S**  
**FSP 100**



**de** Originalbetriebsanleitung 4  
**en** Original instructions 9  
**fr** Notice d'utilisation originale 13  
**nl** Oorspronkelijke gebruiksaanwijzing 18  
**es** Manual original 23  
**fi** Alkuperäinen käyttöohje 28

**no** Originalbruksanvisning 32  
**pl** Oryginalna instrukcja obsługi 36  
**hu** Eredeti üzemeltetési útmutató 41  
**ru** Оригинальное руководство по эксплуатации 46  
**cs** Originální návod k použití 52  
**uk** Оригінальна інструкція з експлуатації 56

## FSP 600 LVLP

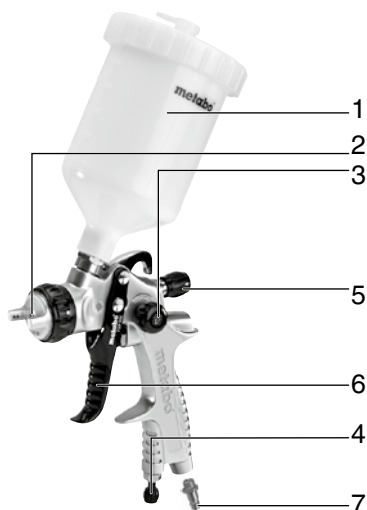

## FSP 600 HVLP

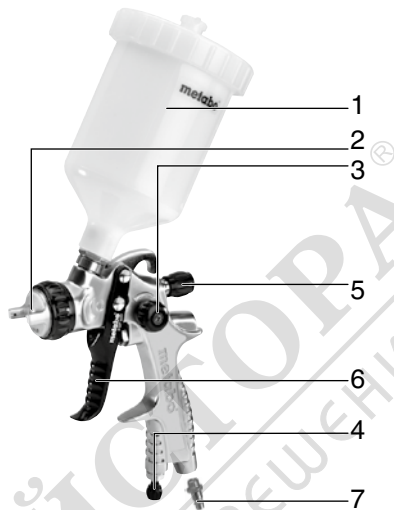

## FSP 1000 S



## FSP 600

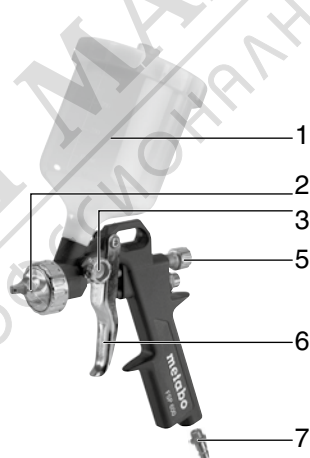

## FSP 100

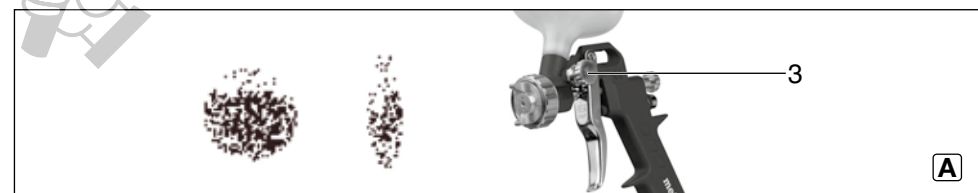
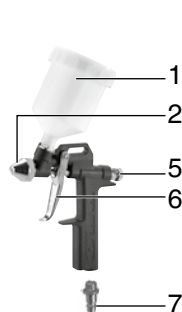

		FSP 600 HVLP	FSP 600 LVLP	FSP 600	FSP 1000 S	FSP 100
<b>*1) Serial Number</b>		01577..	01578..	01575..	01576..	01574..
<b>V<sub>1</sub></b>	<b>l/min</b>	170	136	150 - 260	150 - 260	50 - 100
<b>p<sub>max.</sub></b>	<b>bar</b>	3	3	8	8	3,5
<b>p</b>	<b>bar</b>	1 - 3	1,6	3 - 5	4,5	3,5
<b>V<sub>F</sub></b>	<b>l</b>	0,6	0,6	0,5	-	0,1
<b>V<sub>S</sub></b>	<b>l</b>	-	-	-	1	-
<b>d<sub>i</sub></b>	<b>mm (in)</b>	10 ( <sup>3</sup> / <sub>8</sub> )	10 ( <sup>3</sup> / <sub>8</sub> )	10 ( <sup>3</sup> / <sub>8</sub> )	10 ( <sup>3</sup> / <sub>8</sub> )	10 ( <sup>3</sup> / <sub>8</sub> )
<b>C</b>	<b>“</b>	<sup>1</sup> / <sub>4</sub>	<sup>1</sup> / <sub>4</sub>	<sup>1</sup> / <sub>4</sub>	<sup>1</sup> / <sub>4</sub>	<sup>1</sup> / <sub>4</sub>
<b>A</b>	<b>mm</b>	150 x 115x 340	150 x 115x 340	150 x 100 x 320	200 x 115 x 240	112 x 55 x 240
<b>m</b>	<b>kg (lbs)</b>	0,7 (1.5)	0,7 (1.5)	0,6 (1.3)	0,7 (1.5)	0,5 (0.4)
<b>D</b>	<b>mm</b>	Ø 1,3	Ø 1,3	Ø 1,5	Ø 1,5	Ø 1,0



\*2) 2006/42/EC

\*3) EN ISO 12100:2010, EN 1953:2013

2016-02-01, Volker Siegle  
 Direktor Produktentstehung & Qualität (Vice President Product Engineering & Quality)  
 \*4) Metabowerke GmbH - Metabo-Allee 1 - 72622 Nuertingen, Germany

# Original instructions

## 1. Declaration of Conformity

Under our sole responsibility, we hereby declare that these paint spraying guns, identified by type and serial number \*1), meet all relevant requirements of directives \*2) and standards \*3). Technical documents for \*4) - see Page 3.

### For UK only:

**UK** We as manufacturer and authorized person to **CA** compile the technical file, see \*4) on page 3, hereby declare under sole responsibility that these paint spraying guns, identified by type and serial number \*1) on page 3, fulfill all relevant provisions of following UK Regulations S.I. 2008/1597 and Designated Standards EN ISO 12100:2010, EN 1953:2013

## 2. Specified Use

The compressed air paint spraying gun is designed for applying varnishes and paint to surfaces designated for this purpose. Only the FSP 600 HVLP and FSP 600 HVLP are suitable for use with water-based varnishes.

The compressed air used must be cleaned and be free of condensate and oil.

This air tool must only be operated with a compressed air supply. The maximum supply pressure specified on the air tool must never be exceeded. The tool must not be operated using explosive, inflammable or hazardous gases. It must not be used as a lever, crushing tool or striking tool.

Any other use does not comply with the intended purpose. Unspecified use, modification of the air tool or use of parts that have not been tested and approved by the manufacturer can cause unforeseeable damage.

The user bears sole responsibility for any damage caused by improper use.

Generally accepted accident prevention regulations and the enclosed safety information must be observed.

## 3. General Safety Instructions



For your own protection and for the protection of your air tool, carefully observe all parts of the text that are marked with this symbol!



**WARNING** – Reading the operating instructions will reduce the risk of injury.



**WARNING** Read all safety warnings and instructions. Failure to follow all safety warnings and instructions may result in electric shock, fire and/or serious injury.

**Keep all safety instructions and information for future reference.**

Pass on your air tool only together with these documents.

- The user or user's employer must evaluate the specific risks associated with each application of the tool.
- You must read and understand the safety instructions before installing, operating, repairing or maintaining the tool, and also before replacing any accessory parts or carrying out any work in the vicinity of the air tool. Failure to read and follow the instructions may lead to serious injury.
- Only qualified, trained operators are authorised to install, adjust or use the air tool.
- The air tool must not be modified. Any modifications implemented may reduce the efficiency of the safety measures and increase risks for the operator.
- Never use air tools that have been damaged. Look after your air tools carefully. Regularly check that all moving parts are functioning correctly without jamming. Also regularly ensure that no parts are broken or damaged to an extent that they affect the operation of the air tool. Check that all signs and labels are legible and intelligible. Have damaged parts repaired or replaced before using the tool. Many accidents are caused by poorly maintained air tools.

## 4. Special Safety Instructions

### 4.1 Risks associated with ejected parts

- If either accessory parts or the air tool breaks, parts may be ejected at high speed.
- While operating, maintaining or repairing the air tool, or replacing accessory parts, you must always wear impact-resistant safety goggles. The degree of protection required for each individual task must be evaluated separately in each case.
- Ensure that the workpiece is securely attached.
- Disconnect the air tool from the compressed air supply before replacing the mounted tool or accessories, and also before carrying out maintenance, settings or cleaning.
- Also ensure that no other people are placed at risk.

### 4.2 Risks during operation

- Ensure you stand in a safe position and keep your balance at all times.
- Avoid accidental operation. If the air supply is interrupted, switch off the air tool using the On/Off switch.
- Wear personal protective equipment and always wear safety glasses. By wearing personal protective equipment such as gloves, protective clothing, a dust mask, non-skid safety shoes, a safety helmet or ear protectors, to suit the type of machine and its use, you reduce the risk of injury. Wearing this equipment is recommended.

### 4.3 Risks associated with recurring movements

- When working with the air tool, you may experience an uncomfortable sensation in your hands, arms, shoulders, neck or other body parts.

- Make sure you are in a comfortable position to carry out work with the air tool, check that the tool is held securely, and avoid any awkward positions that make it difficult, for example, to keep your balance. If carrying out work over an extended period, you/the operator should change position occasionally. This should help to avoid fatigue and any unpleasant sensation.
- If the operator experiences persistent symptoms such as feeling unwell, aches, pains or throbbing, a prickling or burning sensation, loss of hearing, or joint stiffening, these warning signs must not be ignored. The operator should advise the employer of these symptoms and consult a qualified doctor.

#### 4.4 Risks associated with accessory parts, consumable materials

- Disconnect the air tool from the air supply before securing or replacing the accessory part.
- Only use accessories or consumable materials that are designed for this tool and that fulfil the requirements and the specifications listed in these operating instructions.

#### 4.5 Risks in the workplace

- Slipping, tripping and falling are the main reasons for accidents in the workplace. Pay attention to surfaces that may have become slippery as a result of using the air tool, and also be careful that the air hose does not cause someone to trip.
- Proceed carefully when working in unfamiliar environments. Power cables and other supply lines may represent a hidden risk.
- The air tool is not designed for use in explosive environments and is not insulated against contact with sources of electric power.

#### 4.6 Risks associated with dust and vapours

- The dust and vapours generated when the air tool is used may carry health risks (e.g. cancer, birth defects, asthma and/or dermatitis); it is therefore imperative that a risk assessment is carried out in relation to these risks and that suitable controls are then implemented.
- The risk assessment should take into account both the dust generated while the air tool is used and any existing dust that may be raised during operation.
- The air tool must be operated in accordance with the recommendations set forth in these instructions and must be maintained in order to minimise the release of dust and vapours.
- The extracted air must be discharged in such a way that, in a dust-filled environment, the minimum of dust is raised.
- If dust or vapours are generated, the main priority is to control these at the point where they are released.
- To avoid increasing the amount of dust or vapours generated unnecessarily, the consumables must be selected, maintained and replaced in accordance with these instructions.
- Use protective breathing apparatus in accordance with your employer instructions or in accordance with health and safety regulations.

- Working with certain materials causes emissions of dust and vapours that can give rise to potentially explosive conditions.

#### 4.7 Additional safety instructions

- Compressed air can cause serious injury.
- Whenever the air tool is not in use, and before replacing accessory parts or when carrying out repairs, you must ensure that air supply is shut off, that the air hose is depressurised and that the air tool is disconnected from the compressed air supply.
- Never direct the air jet at yourself or other people.
- Whiplashing hoses can cause serious injury. Therefore always check that the hoses and their fixtures are in good condition and that they have not become loose.
- Connect the air tool with quick-action coupling to the compressed air supply.
- Ensure that the maximum pressure specified on the air tool is not exceeded.
- Never carry air tools by the hose.

#### 4.8 Additional safety instructions

- If applicable, observe any particular health and safety or accident prevention regulations governing the use of compressors and compressed air tools.
- Ensure that the maximum supply pressure specified in the Technical Specifications is not exceeded.
- Do not operate the tool unless you are completely focused. You must be alert, pay attention to what you are doing and proceed cautiously when working with an air tool. Never use a tool when you are tired or under the influence of drugs, alcohol or medication. Just one moment's carelessness when using the tool can cause serious injury.
- Make sure your workplace is clean and well lit. Untidy or poorly lit workplaces can cause accidents.
- Keep air tools away from children.
- Do not store the tool outdoors or in damp conditions without protection.
- Protect the air tool, especially the compressed air connection and the control elements from dust and dirt.
- Take suitable precautionary measures to protect yourself and your environment against accidents.
- The spraying gun is not suitable for treating food supplies and medication.
- Do not smoke, ignite sparks or light a fire.
- It is essential to ensure that the working area is well ventilated.
- Always wear protective clothing, in particular, breathing protection with active carbon filter.
- Only use the spraying gun for its intended purpose.
- Caution with combustible materials.
- Only start work if you are well rested and focused.
- Never direct the spraying gun at persons or animals.
- The compressed air supply must be connected via a quick-action coupling.
- The supply pressure setting must be made via a pressure reducer.

- Never use oxygen or combustible gases as power sources.
- Prior to maintenance work and troubleshooting, disconnect the tool from the power source.
- Residual cleaning agent and paint must be disposed of in accordance with local environmental regulations.
- During operation, maintenance and cleaning of the paint spraying gun, always wear protective equipment approved for the application case! Use suitable protective gloves, work clothing, safety goggles and breathing protection with a filter element suitable for the respective application!
- There is a risk of the injection of coating material or cleaning fluid (e.g. when changing nozzles or during cleaning)! Serious consequence can result if the protective equipment is inadequate (e.g. necroses, loss of limbs). There is also a risk in the case of inhalation, contact or absorption of coating materials or cleaning fluids. For this reason, always provides adequate technical or natural ventilation!
- Do not use the equipment in potentially explosive atmospheres. Do not process materials that can create potentially explosive atmospheres. Ensure that only suitable compressed air is used!

Information in these operating instructions is categorised as shown below:

 **Danger!** Risk of personal injury or environmental damage.

 **Caution.** Risk of material damage

#### 4.9 Symbols on the air tool

 Read the operating instructions before starting to use the machine.

 Wear safety goggles.

 Wear ear protectors.

## 5. Overview

See Page 2.

- 1 Flowing cups/suction cups
- 2 Nozzle head
- 3 Regulating screw for round or wide-spray jets \*
- 4 Air volume regulation \*
- 5 Regulating screw for paint volume
- 6 Trigger lever
- 7 Plug-in nipple 1/4" \*

\* depending on features

## 6. Operation

### 6.1 Before using the tool for the first time

Insert plug-in nipple (7).

### 6.2 Setting paint jet:

**Round jet / wide-spray jet** (depending on features):

Use the regulating screw (3) to set the spraying gun to a round or wide jet. See Fig. A, Page 2.

Round jet for small surfaces, corners and edges.

Wide jet for large surfaces. The nozzle head (2) can be turned steplessly into vertical or horizontal position.

**Paint volume (application speed):**

Set the paint volume at the regulating screw (5).

Open the regulating screw (5) by approx. 2 to 2 1/2 rotations and carry out a spray test.

Additional opening of the regulating screw (5) increases the paint flow and thus the application speed.

Closing the regulating screw (5) reduces the paint flow and thus the application speed.

Because the material types vary, the paint volume adjustment should always be carried out during operation of the paint spraying gun.

**HVLP (High Volume, Low Pressure): (depending on features)**

Min. supply pressure 0.7 bar at nozzle set, transfer rate approx. 70%. Low overspray, maximum transfer efficiency combined with low air consumption; paint savings are up to 30%.

**HVLP (High Volume, Low Pressure): (depending on features)**

Min. supply pressure 0.7 bar at nozzle set, transfer rate approx. 73%. Low overspray, maximum transfer efficiency combined with very low air consumption.

### 6.3 Using the air tool

To benefit from the air tool's full performance, always use compressed air hoses with an inner diameter of at least 10 mm. Tool performance can be significantly impaired if the inner diameter is too small.

 **Caution.** The compressed air line must not contain any water condensation.

 **Caution.** The compressed air used must be cleaned and be free of condensate and oil.

1. Ensure that the air volume regulation (4) (depending on features) is fully open prior to operation. It can be used for fine adjustment of the air volume during operation.
2. Adjust the supply pressure (this is measured at the air outlet while the air tool is switched on). For details of the maximum permissible supply pressure, see the section on "Technical Specifications".

If the supply pressure is too high, this can result in excessively fine distribution of the material accompanied by rapid fluid evaporation. The surfaces become rough with poor adherence.

If the supply pressure is too low, the material is insufficiently atomised. The surface will be wavy with paint drips.

3. Connect the air tool with quick-action coupling to the compressed air supply.
4. Observe the manufacturer's instructions on paint conditioning. Fill paint into the cup (1). Seal with cover.
5. Actuate the trigger lever (6) to put the paint spraying gun into operation.
6. Set the paint jet (see Section 6.2).
7. Always hold the spraying gun the same distance away from the object. Spraying distance is approx. 10-15 cm.

## 7. Cleaning, Maintenance and Care

 **Danger!** Disconnect the compressed air connection before carrying out any work.

 **Danger!** Repair and maintenance work other than the work described in this section should only be carried out by **qualified specialists**.

If there is an unexpected blockage or the spray pattern is contaminated, please clean the nozzle.

- A clean paint spraying gun guarantees trouble-free handling during subsequent work.
- Clean and service the paint spraying gun immediately after painting with extreme care.

 **Danger!** Do not use halogen solvents containing hydrocarbons (1.1.1 Trichloromethyl, ethyl chloride, etc.) because this results in chemical reactions, some of which can be dangerous, with some spraying gun materials.

 **Caution.** Never immerse the spraying gun completely in a solvent.

- All moving parts should be oiled from time to time.
- If the nozzle is removed for cleaning, the thread and the gasket must be coated with a light grease. Do not use lubricants containing silicone.
- Store your air tools in dry rooms only.
- Carry out regular maintenance to ensure the safety of the air tool.
- Check that all screw fittings are seated securely, and tighten if necessary.
- Avoid contact with dangerous substances that have accumulated on the tool. Wear suitable personal protective equipment and take appropriate measures to remove any dangerous substances before maintenance.

## 8. Accessories

Use only genuine Metabo accessories.

Only use accessories that are designed for this air tool and that fulfil the requirements and the specifications listed in these operating instructions.

The nozzle and nozzle needles are wear parts. We recommend therefore that you always keep a spare nozzle set in stock.

For a complete range of accessories, see [www.metabo.com](http://www.metabo.com) or the catalogue.

## 9. Repairs

 **Danger!** Repairs to air tools must only be carried out by qualified specialists, using original Metabo spare parts!

If you have Metabo air tools that require repairs, please contact your Metabo service centre. For addresses see [www.metabo.com](http://www.metabo.com).

You can download spare parts lists from [www.metabo.com](http://www.metabo.com).

## 10. Environmental Protection

Observe national regulations on environmentally compatible disposal and on the recycling of disused air tools, packaging and accessories. You must not cause risks to people or the environment.

## 11. Technical Specifications

Explanatory notes on the specifications on Page 3.

Subject to change in line with technological advances.

$V_1$	=	Air requirement
$p_{max}$	=	Maximum permissible supply pressure
$p$	=	Supply pressure
$D$	=	Nozzle site
$V_F$	=	Volume of flowing cup
$V_S$	=	Volume of suction cup
$d_i$	=	Hose diameter (inner)
$C$	=	Connecting thread
$A$	=	Dimensions: Length x Width x Height
$m$	=	Weight

The technical specifications quoted are subject to tolerances (in compliance with the relevant valid standards).

### Emission values

Using these values, you can estimate the emissions from this tool and compare these with the values emitted by other tools. The actual values may be higher or lower, depending on the particular application and the condition of the tool or mounted tool. In estimating the values, you should also include work breaks and periods of low use. Based on the estimated emission values, specify protective measures for the user - for example, any organisational steps that must be put in place.

Sound level (EN ISO 14462):

$L_{pA}$	=	Sound pressure level
$L_{WA}$	=	Acoustic power level
$K_{pA}, K_{WA}$	=	Measurement uncertainty

 **Wear ear protectors!**