

GB*Operating, maintenance, spare parts manual*

BENDING MACHINE

PS32-36-40-45-50-55



Macchine Edili e Stradali s.r.l.
Via S.Gimignano n°96
Poggibonsi (SI)- Italy

Sito internet : www.sillaitaly.com



REL. 4 Date 22/11/2018

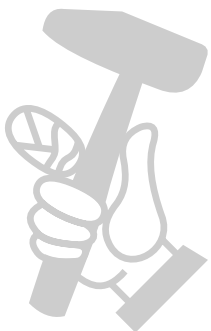

TABLE OF CONTENTS		Page
1	INTRODUCTION AND PROVISIONS	22
2	MARKING	22
2	ABBREVIATION LIST	23
3	GENERAL PRECAUTIONS	23
4	CHARACTERISTICS	24
4.1	Description of the machine	24
4.1.1	<i>Direction as to how to use</i>	24
4.1.2	<i>Safety devices</i>	24
4.2	Technical characteristics and dimensions	24
4.3	Safety prescriptions	25
4.4	Noise	25
4.5	Conformity with safety regulations	26
5	INSTALLATION/NEW BUILDING YARD	26
5.1	Transport	26
5.2	Placing and earthing	26
5.3	Areas of respect and dimensions	27
5.4	Pre-operation checklist	27
5.5	Safety first	27
5.6	Putting into operation	27
5.7	Electric installation	27
5.8	Diagrams	28
5.8.1	Wiring diagram	28
5.9	Training	28
6	ADJUSTMENTS	28
6.1	Adjusting the machine	28
7	OPERATION	29

INDICE		Page
7.1	Control instruments	29
7.2	Machine operation and controls	29
7.2.1	<i>Turntable speed</i>	29
7.2.2	<i>Positioning of working benches</i>	29
7.2.3	<i>Push-button controls</i>	29
7.2.4	<i>Foot-switch</i>	29
7.2.5	<i>Device for pre-setting</i>	29
7.2.6	<i>Use for bending roller and pins</i>	30
7.3	Operation of the machine	30
7.3.1	<i>Bending of stirrups and polygonal spirals</i>	30
7.3.2	<i>Bending of round spirals</i>	30
7.3.3	<i>During operation</i>	32
7.3.4	<i>Warning signs</i>	32
8	MAINTENANCE	33
8.1	Recommended lubricants	33
8.2	Ordinary maintenance	34
8.3	Extraordinary maintenance	34
8.4	Bolt torque	34
8.5	Troubleshooting	34
8.6	Ordering spare parts	34
9	DISMANTLING	34
9.1	Disassembling and dismantling	34
9.2	Demolition	36
10	DECLARATION OF CONFORMITY	35
11	WARRANTY REGISTRATION FORM	37
12	SPARE PARTS MANUAL	De 39

1. INTRODUCTION AND GENERAL PROVISIONS

This manual is directed at the user and operator who will be responsible for the safe, efficient and trouble free operation of the machine. Read and understand this manual and always follow the safety precautions outlined in the Instruction and Safety Manual. Keep this manual handy for frequent reference and to pass on to new operators or owners.

The machine is equipped with tested special safety devices and safety systems. SILLA cannot be held responsible for unauthorized modifications or procedures, replacements and/or all other modifications changing the use the machine has been designed and manufactured for.

The instruction manual for use and maintenance is an integral part of the machine and must be kept for future reference until final decommissioning of the machine.

This manual must be kept in a protected place. Should the manual be lost or irreparably damaged, a new copy may be requested at the local sales representative or at the Manufacturer, by specifying type, part number and year of construction of the bending machine.

Warranty: The mechanical and electrical products of the machine, which are not normal service items, have a one-year warranty starting from the date of the sale. The warranty does not cover the normal service items like tools, driving belts, liquids and oils.

The defective or not properly working product will be replaced by the Technical Personnel of the Manufacturer of the machine, after the defective product has been proven to be defective. The warranty does not cover the products in case of modification, abuse, misuse, improper use, negligence or improper maintenance (routine and extraordinary maintenance) as shown by this I.M. This warranty is valid in the territory of the European Community. The consumer is the right holder according to the applicable national laws governing the sale of consumables and this warranty makes those rights unprejudiced.

2. MARKING A label with the following machine identification data is located on the machine:

EC marking according to EC directive 2006/42, Enclosure III;

Name and address of the manufacturer and/or legal representative in Europe;

Machine designation; Machine type;

Serial or part number; Year of construction;

For assistance and information or spare parts, refer to:

SILLA Macchine Edili e Stradali Srl

Via S.Gimignano , 96

53036 – POGGIBONSI (SI) - ITALIA

Tel. ++39-0577 - 938051 Fax. ++39-0577 – 981609

E-mail: info@sillaitaly.com - Website: www.sillaitaly.com

This INSTRUCTION MANUAL and all the enclosed documents are freehold property of the Company SILLA.

Reproduction (in any form or way inclusive recording and photocopy) in whole and/or part is forbidden without the written authorisation of the Company SILLA.

In case this Instruction Manual should get lost or destroyed ask the Company SILLA for a complete copy.

LIST OF ABBREVIATIONS AND DEFINITIONS USED IN THIS MANUAL



Danger	Source of probable injuries to the health
Dangerous area	Any area inside and/or next to a machine where the presence of a person is a risk for the safety and the health of said person.
Exposed person	Any person, in whole or in part, inside a dangerous area.
Operator	Person or persons having the task of install, making it work, regulating it, carrying out maintenance procedures, cleaning, repairing and transporting a machine.
Hazard	Combination of probabilities and seriousness of probable injuries to the health in a dangerous situation.
Guard	Machine element specifically used for granting protection by means of a material barrier.
Protection device	Device (other than a guard) reducing the hazard, alone or together with a guard.
Authorized use	The use of the machine according to the information given by the instructions for use.
Not authorized but reasonably predictable use	The use of the machine different from that shown in the instructions for use, but which can derive from easily predictable human behaviour.
	Caution: precautions and instructions to be strictly followed.

3. GENERAL PRECAUTIONS



- The operating safety of the machine is only granted for the functions listed in this instruction manual. **SILLA** cannot accept any responsibility, if the machine should be used for different uses than those listed in this manual or uses, which do not comply with the operating instructions.

• **SILLA** cannot accept any responsibility for safety, liability and performances of the machine, if the precautions and the instructions of this instruction manual, especially referred to use, on building yards, maintenance and dismantling are disregarded.

- The correct use of this bending machine implies good knowledge of these instructions for use and the hazards connected with its possible incorrect use.
- Consequently, the bending machine shall only be used by skilled and authorised personnel. The operator using the bending machine shall be trained on its correct use, the relevant protection devices and the accessory tools.
- The operating safety of the machine is only guaranteed for the functions and the materials listed in this instruction manual.
- SILLA cannot accept any responsibility, if the bending machine is used for other purposes than those outlined in this manual and which do not comply with the operating instructions.
- The machine shall not be used in places with the presence of gas, inflammable liquids or other inflammable materials. The machine shall not be installed in environments with risk of explosion.
- SILLA cannot accept any responsibility for safety, liability and performances of the bending machine, if the precautions and the instructions of this instruction manual, especially referred to: use, ordinary and extraordinary maintenance and repair are disregarded.
- The electric installation of the user shall comply with the CEI 64.8 standards (CENELEC HD 384).
The manufacturer cannot accept any responsibility , if the bending machine is properly connected to the unipotential
- For maintenance works needing some components to be replaced, only use original spare parts or spares authorized by the Technical Dept. of Silla.
In particular, ensure the maintenance of the electric installation is carried out by specialised and authorised personnel and by using original components.
- However, for service or repair works always refer to the After-Sales Service recommended by the supplier of the machine.
- The user of the bending machine takes full responsibility for its good and safe operation, if the machine was not repaired or maintained by the specialized or authorised personnel.
- The bending machine is delivered with the protection devices already installed and fixed. Check and maintain these protection devices and the machine per the schedule recommendations.
- Do not wear any jewellery or clothing that can get caught or distract from the operation of the machine.
- Ensure good lighting (natural or artificial) of the bending machine and the control panel to avoid shady areas, dangerous dazzling and stroboscopic effects.
- For extraordinary maintenance and repair use only original spare parts. For all repairs, please refer to the After-Sales Service authorised by the supplier of the machine.
- All the above-mentioned operations shall be carried out in an appropriate place after switching off the machine and disconnecting the electric supply cable, in order to prevent other persons from starting the machine.
- All the operators using the machine shall be trained on its correct use, the safety devices, the behaviour and actions to perform for a correct use of the machine and operators' safety.
- During the use on the construction site, the machine shall be protected against falling objects by means of a solid plank covering (see also art. 114 DLgs 81/08)
- The machine is delivered with the protection devices already installed; however, the operator shall check their good working before starting to use the machine. Check and maintain these protection devices and the machine per the schedule recommendations. The operator shall reflect upon the possible consequences before approaching with his hands, in particular:
 - **NEVER SWITCH ON THE MACHINE WITHOUT THE PROTECTION SHIELDS;**
 - **NEVER REMOVE AND NEVER OPEN THE PROTECTION SHIELDS WHEN THE MACHINE IS RUNNING.**
 - **NEVER SWITCH ON AND NEVER START WORKING WITH THE MACHINE IF THERE ARE BYSTANDERS.**
- The machine has a considerable mass; therefore do not use it in case of storms. Electrocution hazard!
- Clear the area of unauthorized personnel or obstacles, before starting work.

- The operator shall wear appropriate clothing: work gloves, safety shoes, etc. Do not wear any jewellery or clothing that can get caught on the machine.
- Follow the safety precautions, in particular:
 - Switch off the machine before opening or cleaning it; ensure no one can turn it on by accident;
 - Use the protective equipment (work gloves, earmuffs, safety shoes, respiratory protection) during use, assembly and maintenance of the machine;
 - Be cautious in approaching all the moving parts.
 - **Follow the safety instructions shown in chapter SAFETY PRECAUTIONS.**

4. CHARACTERISTICS

4.1 Description of the machine The combined bending-cutting machine has been designed and built for bending different diameters of reinforced-concrete rods in various configurations. Different production performances of the bending machine can be achieved, according to several external factors and depending on the type of reinforced-concrete rod being machined.

The bending machine has an electro-welded and reinforced sheet metal structure. The following are the machine units:

- **Turntable unit:** This unit consists of a turntable, an airtight box containing the worm reduction unit and crown gear (permanent lubrication), vertical output shaft for activating the turntable and horizontal input shaft. A sheave is splined to this shaft, which is moved by the main electric motor.
- **Device for pre-setting of bending angle:** This unit consists of a bending sector for pre-setting the bending angle and the relevant mechanisms.
- **Control board:** Electric box containing the power components. On the door of the control board there are placed the machine controls.
- **Set of bending rollers, pins and stirrup bending accessories:** Set of bending accessories of the bending machine.

4.1.1 Direction as to how to use.

The bending machine is directed to the industrial or handicraft sector, for the machining of products for building yards.

4.1.2 Safety devices. The bending machine is equipped with the following fixed and mobile protection devices:

1. Hinged cover protecting the turntable area and the work area. The opening of the cover is controlled by means of a safety limit switch, which stops the machine.
2. Knob-screwed door closing the belt drive area between the motor and the reduction unit. This door is fixed by means of screws, which need a wrench to be unscrewed and removed; it is equipped with a safety switch stopping the machine in case of opening.



Do not alter or bypass any active safety devices installed on the bending machine.

4.2 Technical characteristics and dimensions :

Technical data of bending machines :

DIMENSIONS	PS 32	PS 36	PS 40	PS 45	PS 50	PS 55
LENGTH (mm)	890	960	1040	1040	1040	1040
WIDTH (mm)	770	880	820	820	820	820
HEIGHT (mm)	840	840	900	900	900	900
WEIGHT (Kg)	300	400	540	540	580	700
ELECTRIC MOTOR (HP)	4	4	4	5	5	7,5

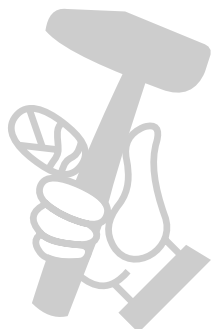

TECHNICAL CHARACTERISTICS					
Mod.	Turntable rpm	Number of pieces for double bendings	45 Kg/mm ²	65 Kg/mm ²	85 Kg/mm ²
			Rod Ø in mm.		
PS-32	12-18	1	32/26	26/22	24/20
		2	22/18	18/16	16/14
		3	18/16	16/14	14/12
PS-36	7-14	1	36/26	30/24	26/22
		2	24/20	22/18	20/16
		3	22/18	20/16	18/14
PS-40	6-12	1	40/28	34/26	30/24
		2	26/22	24/18	22/16
		3	24/18	22/16	20/14
PS-45	6-12	1	45/30	36/26	32/24
		2	32/22	24/18	22/16
		3	26/18	22/16	20/14
PS-50	4-7	1	50/36	40/30	36/28
		2	34/26	28/22	26/20
		3	28/22	24/18	24/16
PS-55	4-7	1	55/40	45/35	40/30
		2	38/28	30/24	28/22
		3	30/24	28/20	24/18



4.3 SAFETY PRESCRIPTIONS Limits for use, space, endurance

The bending machine has been designed for continuous working 8 hours/day; it can also be used for 16 or 24 hours/day by suffering a proportional loss of endurance. The electrical connection shall be carried out and used according to the parameters shown in the wiring diagram table 5.8.1 .

The bending machine shall be installed in a covered place with ambient temperature between +5° C and + 40° C and humidity up to 90 % at 20° C.

Lack of appropriate maintenance, as recommended in section 8, will reduce both endurance and reliability of the bending machine.

Do not use the machine in places at risk for explosions or fires (gas/powders) (no Ex protection).

The bending machine performances may be different, according to several external factors and to the type of product being processed. In view of its specificness it is not possible to use the bending machine for purposes other than those outlined in this instruction manual. Furthermore, the manufacturer cannot foresee other ways of using the machine, according to para. 1.1.2 letter C of EEC directive 89/392.

Ensure the areas of respect of the machine, according to its range of action and the relevant work area, also in view of the dimensions of the materials to bended.

Do not exceed machine limits. Do not modify the machine to improve its performances.

Leaving the machine unattended in public places is dangerous. Therefore, provide appropriate barriers around the work area to prevent unauthorized persons from approaching it.

Do not make attempts to repair the machine, always call authorized repair shops.

Before connecting or disconnecting any electric component, you must know very well the electric system. A wrong connection may cause injuries and damages.

The electric installation of the user shall comply with CEI 64/8 standards and Law 46/90; it shall be equipped with automatic protection devices, which are coordinated with the earthing system. Ensure good lighting in the work area and around the machine, in order to avoid shady areas, dangerous dazzling and stroboscopic effects. The Manufacturer cannot accept any responsibility, if the bending machine is not properly connected to the unipotential earthing system and if there are no protection devices installed upstream the machine, which are coordinated to ensure automatic cut-off, according to the standards mentioned before.

The scrap materials, which are produced during the machining, must be collected and sent to specialized companies for disposal, according to the laws in force, in order to protect the environment.

The materials to be processed with their minimum/maximum dimensions are those stated in table 4.2 .

Although the user strictly follows the instructions for use, there still might be some residual hazards during the use of the machine: hands getting crushed between support bar and rolls of the rod to be bended, the rod may bump against the body, dragging by the bar and the rolls, objects falling on the lower limbs.

The machine shall be used by qualified and healthy adults only.



CAUTION!!!!!! EVERY USE OF THE MACHINE DIFFERENT THAN THOSE OUTLINED BY THE MANUFACTURER IN THIS INSTRUCTION MANUAL IS AN IMPROPER USE. THEREFORE, THE COMPANY SILLA CANNOT ACCEPT ANY RESPONSIBILITY, IF THE MACHINE SHOULD BE USED BY THE OPERATOR FOR DIFFERENT USES THAN THOSE LISTED IN THIS INSTRUCTION MANUAL OR THOSE NOT COMPLYING WITH THE OPERATING INSTRUCTIONS.

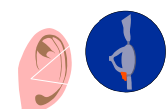

4.4 Noise

The following table informs on:

- the noise emission level of the Bending Machine measured at the operator's ear does not exceed the maximum value of 63 Pa, according to UNI 11200 standard.

In order to not increase the noise level strictly follow these rules:

- Clean and grease the machine elements per the schedule recommendations;
- Ensure no machine parts are obstructed or damaged.



With this noise emission level the use of protective equipment like earmuffs, earplugs, etc. **is not mandatory** but recommended. The factors affecting the worker's real exposition level include the duration of the exposition, the environmental characteristics, other emission sources like for example the number of adjacent machines and types of machining. The single exposition levels may also differ from country to country. However, thanks to this information the user of the machine can better evaluate hazards and risks.

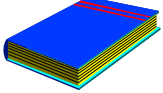

4.5 Conformity with safety regulations

The bending machine has been designed and built in accordance with the following standards:

"Machinery Safety Directive" EC 2006/42 published in the Official Gazette of European Union on June 9, 2006.

" Electromagnetic Compatibility Directive " EC 2004/108 , published in the Official Gazette of European Union on December 31, 2004.

- EN ISO 12100-1 (2003) Safety of machinery - basic concepts, general principles of design – Part 1: basic terminology, methodology.
- EN ISO 12100-2 (2003) Safety of machinery - basic concepts, general principles of design – Part 2: technical principles.
- EN ISO 14121-1 (2007) Safety of machinery – risk evaluation -Part 1: principles
- EN ISO 13857 (2008) Safety of machinery - safety distances to prevent the upper and lower limbs from attaining dangerous areas.
- EN ISO 13850 (2008) Safety of machinery – emergency stop – principles of design.
- EN ISO 13849-1 (2008) Safety of machinery - parts of the control systems concerning safety -Part 1 : general principles of design.
- EN ISO 13849-1 (2008) Safety of machinery - parts of the control systems concerning safety -Part 2 : validation

5.INSTALLATION / NEW BUILDING YARD

5.1 Transport

The bending machine is delivered to the Customer fully assembled and tested.

The packed machine, protected with proper material, is assembled on the pallet and fixed to it by means of two tie rods. Fix the package to the platform of the means of transport by means of proper retention instruments, such as: special belts, ropes, etc. Unload the machine by means of suitable means, such as fork lifts. Place it onto its wheels on a level soil capable of supporting its weight. Before transporting the machine to another building yard, pack and protect the machine with proper material and fix it to the platform of the means of transport by means of proper retention instruments, such as: special belts, ropes, etc.

The weight of the machines is outlined on the EC plate and in section 4.2 of this manual; due to their considerable weight you must provide accurate loading/unloading means.

Ensure your hoisting equipment has adequate dimensions and capacity.



Be careful during hoisting and handling the machine to prevent injury to persons and damage to the machine. The hoisting equipment shall be dimensioned according to the weight to be hoisted.

The bending machine is delivered together with the following accessories, which are stored inside a special tool box inside the motor compartment of the machine:

- | | | | |
|-----|----------------------------------|-----|----------------------------------|
| - 4 | Allen wrenches sizes 3,5,6,14 | - 1 | flat setscrew wrench sizes 19-22 |
| - 1 | flat setscrew wrench sizes 19-22 | - 1 | 16 A three-phase tap |
| | | - 1 | Foot-switch |



Never hoist the machine by hand, even if you are more than one person: it is too dangerous. Follow the safety instructions shown in chapter SAFETY PRECAUTIONS.

5.2 Placing and earthing

Place the machine on a steady and level soil.



Check the flatness of the soil before installation by means of a water level (longitudinally and crosswise).

The installation place shall be protected against atmospheric agents. During the use on the construction site, the machine shall be protected against falling objects by means of a solid plank covering (see also art. 114 DLgs 81/08). Make sure the soil is correctly dimensioned to support the weight of the machine. It must be self-extinguishing and not combustible.

Next to the machine there must be a 3 P+T 16A plug for the connection with the electric installation.

Connect the machine to the general ground system of the building yard by means of the power cable. Its resistance shall not exceed 883 Ohm, otherwise the bending machine shall be connected to a supplementary ground rod by connecting it to the special ground screw (earth rod see fig. 2). Make sure there is an area of respect of at least 2000 mm around the machine.

During machining the machine produces scrap and dust, which must be disposed of by specialized companies.

Next to the machine there must be:

- Connection to the electric supply mains;
- Areas for the hoisting and handling of work products
- Areas for the collection and discharge of residual products.

GB ELECTRIC SAFETY



When installing the machine on the building yard, connect the metal structure of the machine to a grounding system by means of the



FIG.2

In case the machine shall be connected to a generating set, by means of electrical separation (NOT grounded generating set), the following conditions shall be respected, according to the CEI 64-8 standard:

- the machine shall not be connected to a ground system;
- extension of the circuit below 250 metres;
- realisation of equipotential bonding between machine mass and other equipment mass powered by the same generating set;
- the power cables shall be properly isolated and it shall be possible to inspect their whole length.

However, follow provisions for electrical separations mentioned in the CEI 64-8 standard.



Never use the machine near inflammable or explosive materials and/or in places with the presence of gas. Follow the safety instructions shown in chapter SAFETY PRECAUTIONS. Unauthorised persons shall never use the machine.

Next to the machine installation area there must be the following:

- Electric energy supply; - lightning; - ensure an area of respect around the machine of min. 2 meters.



5.3 Areas of respect and dimensions

The area of respect around the machine shall be at least 2 meters to ensure good working and correct maintenance of the machine. The personnel shall move within this area with the utmost care.

The area of respect operators shall move with the utmost care and eliminate all kinds of obstacles hindering the passage. The work surface may become slippery because of work residuals. Use the personal protective equipment (safety shoes) and frequently clean the floor.



Caution! The use of additives or special products for cleaning the machine may injury the health of the person. Carefully read the prescriptions of the relevant products. These products may also modify the quality of the paint of the bending machine and damage its electric parts.

5.4 Pre-operation checklist

Use work gloves during set-up and setting at work of the machine.

Before the setting at work of the bending machine, especially at first starting or when it is installed on a new work site, the following technical advices and suggestions concerning the various types of connections shall be respected.



5.5 Safety first All the machines can be dangerous. When the bending machine is correctly used and properly maintained, it is a very safe machine. On the contrary, if it is badly used, it may become dangerous. Both in this manual and on the machine there are warning signs showing the possible hazards and how to avoid them.

In case of doubts ask your retailer or your chief for more explanations. Do not operate the machine, if you are not able to control it. Do not start any work until you are not sure about your and other people's safety. You can cause serious damage, if you try to carry out some non-familiar operations, without prior testing on free areas, far from people and on level ground.

Follow the safety instructions shown in chapter 4.3 SAFETY PRECAUTIONS

5.6 Putting into operation

On delivery the machine is connected to 400V (3P+T).

Before starting the machine, ensure the following:

- The characteristics of the electric installation shall comply with the instructions of section 5.8.1.
- the machine shall be grounded by means of a protection wire having the same section of the power cables.
- The feeder voltage shall comply with the motor voltage.
- Grounding according to I.S.P.E.L.S standards is mandatory.
- Change-over to 220 V voltage has to be carried out as follows:

Disconnect the machine from the power connector and make sure the modifications will be done by qualified personnel:

- a) Change the terminal board from "star" to "delta"
- b) Place the electric connection of the transformer at input from 400 V to 230 V.

- Check the area of respect and the work areas; - Check the protections for good fixing;
- Check the caution/danger signs on the machine for good visibility.
- Test all the mechanical and electric machine controls, loadless, to check correctness, efficiency and working.

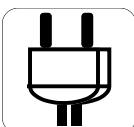

5.7 Electric installation

The electric installation of the user must be in compliance with CEI 64.8 standards (Italian law n. 46/90).

The machine is fitted with an electric plug.

The plug must be connected to the installation of the user according to the maximum electrical input.



Provide the following: - Unipotential grounding system,

- The sum of the discharger resistances and the mass of the protection wires shall be below 883 Ohm.
- The connector shall be of type 3P +T complying with the CEI 23-12 standard . The supply cable shall be of type H07RN-F or expressly indicated by the manufacturer for laying outside in wet environments with a section suitable to the current to be conducted. The cable shall be protected by strong raceways against the passage of means and/or people.

Voltage drop shall be verified according to the following formula:

$$\frac{\Delta V}{V} = K * L * I < 4 \%$$

ΔV = Voltage coefficient L= Length I = Intensity line current in amperes

K= Coefficient (1,73 for three-phase lines) (2 for single-phase lines)

The grounding connection shall be done by means of a self-extinguishing yellow-green cable, its minimum section shall not be below the one of the supply cable. Ensure grounding of all the metallic parts of the machine. Ensure the protection against lightning and/or electric discharges.

For installations on building yards, connect the grounding system of the building yard to the additional external earthing plug, placed on one machine leg: use a copper cable with a minimum section of 35 square millimetres provided with cable terminal and fix the cable terminal to the clamp on the leg with a screw nut (Fig. 2).

Ensure good lighting of the machine installation place, according to the work area, and avoid shady areas, dangerous dazzling and stroboscopic effects. The Company cannot accept any responsibility in case of wrong connection of the electric system or bad grounding.

The motor installed on the machine is protected by a magneto-thermal device. The motor is provided with special devices to avoid accidental machine starts after electric cutoff. After the intervention of the thermal protections, reset the device as follows: disconnect the machine from the power supply, open the door by means of the special screwdriver and press the reset pushbutton on the magneto-thermal switch.

All the electric elements and apparatus are protected according to the place of use, they have a protection grade of minimum IP 54 (protection from dust and liquids). The control panel is placed so that is it visible by the operator during the use of the machine. It is provided with a STOP push-button for quick machine stop.

Follow the safety instructions shown in chapter SAFETY PRECAUTIONS.

5.8 Diagrams

5.8.1 Wiring diagram

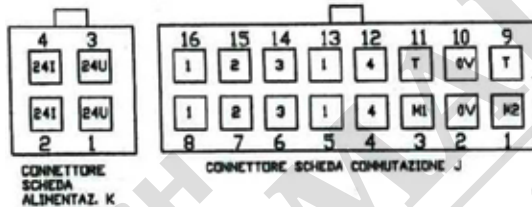

GENERAL FEATURES	
RATED POWER KW	4,0 -5,5
RATED CURRENT A	6 - 8
RATED VOLTAGE V	400
AUXILIARY VOLTAGE V	24
VALUE OF SHORT-CIRCUIT CURRENT MAX.	= 30 KA
DEGREE OF PROTECTION IP 54	

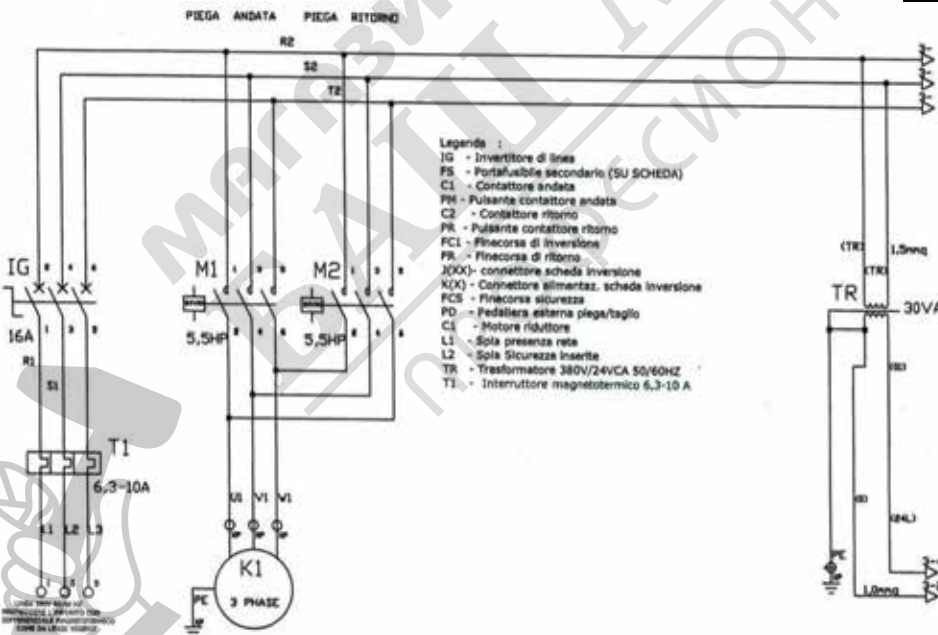

- Legenda :
- IG - Invertitore di linea
 - FS - Portafusibile secondario (SU SCHEDA)
 - C1 - Contattore andata
 - PM - Pulsante contattore andata
 - C2 - Contattore ritorno
 - PR - Pulsante contattore ritorno
 - FR - Pulsante contattore ritorno
 - FC1 - Fincorsa di inversione
 - FR - Fincorsa di ritorno
 - J(X) - Connettore scheda inversione
 - K(X) - Connettore alimentaz. scheda inversione
 - FCS - Fincorsa sicurezza
 - PD - Pedaliera esterna piega/taglio
 - C1 - Motore riduttore
 - L1 - Sola presenza rata
 - L2 - Sola Sicurezza inserita
 - TR - Trasformatore 380V/24VCA 50/60HZ
 - T1 - Interruttore magnetotermico 6,3-10 A

IG	line inverter
FS	secondary fuse carrier (ON CARD)
C1	contactor
PM	contactor push button
C2	return contactor
PR	return contactor push button
FC1	limit switch
FR	return limit switch
J(X)	card connector
K (X)	card feeder connector
FCS	safety limit switch
PD	foot-switch for bending/cutting
C1	reduction unit motor
L1	power on pilot lamp
L2	protections on pilot lamp
TR	transformer 380V/24VCA 50/60 Hz
T1	magnetothermal switch 6,3-10A

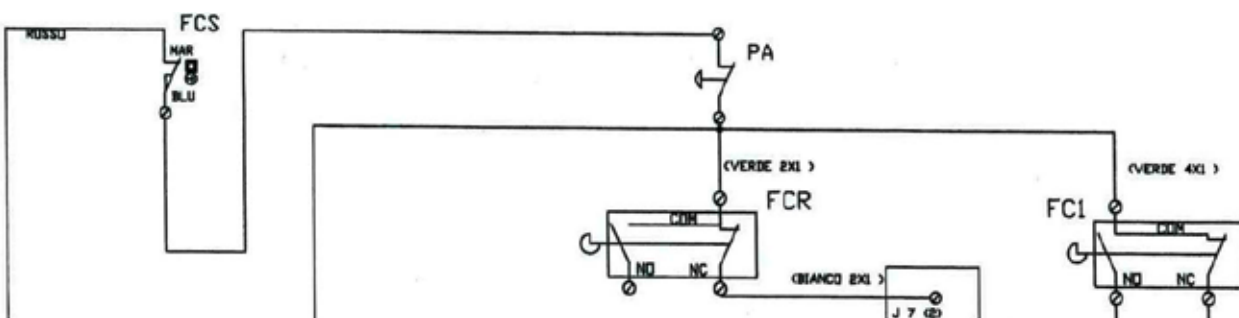



5.9 Training Before starting to use the machine, read this instruction manual and understand how to use the machine in a safe way.

6. ADJUSTMENTS

6.1 Adjusting the machine At first operation on the building yard, the machine does not need any adjustments.

However, we suggest to read the following paragraph: 5.4 Pre-operation checklist.

Never carry out adjustments when the machine is running/working.

Do not alter or bypass any active safety devices installed on the bending machine.



Follow the safety instructions shown in chapter **SAFETY PRECAUTIONS**.

Every single adjustment and/or modification of the safety/work parameters set on the machine, which has not been authorised by the technical personnel of the company Silla or which is not outlined in this instruction manual, may influence the quality of the product and injure the operator's health. The company Silla decline any responsibility for liability, performances and safety of the machine in case of modification/alteration of the machine and of the relevant operation/safety parameters.

7. OPERATION

7.1 Control instruments

The Bending, Return and Stop push-buttons "C" are placed on the door of the electric panel.

On the electric panel there is also a 3-position (1-0-2) current inverter "I" corresponding to the desired direction of rotation.

Both position 1 and 2 have a pilot lamp "B" signalling the relevant position.

Bending can also be carried out by means of the **foot-switch**

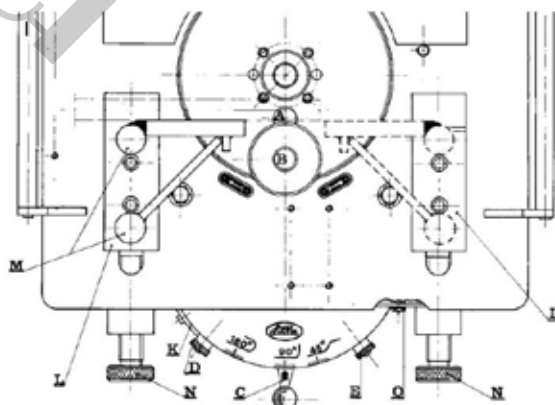
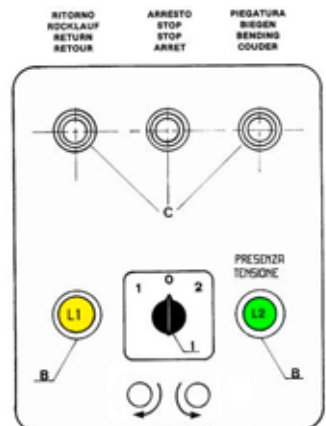

The machine has **two bending speeds** (turntable speeds); the bending speeds can be easily changed by displacing the V-belts from one pulley to the other.

The belts and pulleys are placed inside the machine frame.

The bending machine is equipped with a special device, which allows pre-setting of two bending angles in the range between 20 and 220 degrees.

Lever "C" allows increasing/decreasing of the bending angle according to the position on the device.

During operation, follow the safety instructions shown in chapter **SAFETY PRECAUTIONS**.

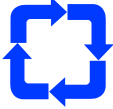

7.2 Machine operation and controls

7.2.1 Turntable speed The machine is equipped with two turntable speeds.

The bending speeds can be easily changed by displacing the V-belts from one pulley to the other. The belts can be accessed through the rear door and are placed inside the machine frame. The technical data of the two bending speeds and the rod quantity are shown on table 4.2. To perform this operation you need first to disconnect the machine from the power supply. If you want to carry out this operation, raise the belt tightening lever; thus the distance between centres will be reduced allowing the displacement of the belts on the pulleys. After belt displacement, retighten the belts by means of the lever. Check belt tightening and adjust, if necessary, by means of the tightening device.

7.2.2 Positioning of working benches We suggest to place the working benches on both machine sides in order to achieve maximum machine performances. Ensure the height of the benches is equal to the height of the machine. Between bench and machine there must be a free space of about 60 cm for operator's passage.

7.2.3 Push-button controls Start the bending machine by means of the inverter "I" and the 3 push-buttons "C".

The right "BENDING" push-button starts the turntable according to the direction of rotation preset by the inverter. The "STOP" push-button in the centre simply stops bending for whatsoever reason, i.e. wrong bending pre-setting, wrong direction of rotation, etc. The left "RETURN" push-button is only used to rotate the turntable to zero position, after the machine has been stopped with the "STOP" push-button.

7.2.4 Foot-switch You can use the foot-switch in place of the "BENDING" push-button, which allow rotation in both directions, according to the inverter position. The foot-switch can be placed in any position around the bending machine, without the necessity of turning the rods around, especially useful when bending stirrups. A bipolar outlet that is fixed laterally to the machine frame allows easy and quick connection. The foot-switch is waterproof and works at low voltage.

7.2.5 Device for pre-setting of bending angle (patented) The bending machine is equipped with a special device, which allows pre-setting of two bending angles in the range between 20 and 220 degrees. Lever "C" allows increasing/ decreasing of the bending angle according to the position on the device. If you want to increase the bending angle, move the lever from the right (20 degrees) to the left. The mostly used bending angles (45 - 90 - 180 degrees), are marked on the device. The shown position is an approximate position, the exact angle depends on the rod diameter and on the applied bending pins and rollers. Since the mostly executed bending angles are 180 degrees for hooks and 45 degrees for bending, the device is equipped with two movable stops "E" - "O" with knurled knobs, which limit the lever displacement to two preset bending angles.

Exact pre-setting of the bending angle is carried out experimentally by means of an iron rod to be bended: slowly displace the lever on the device next to the marks of the desired bending until you achieve the exact angle. Then approach the stop to the lever and lock it with the knurled knob; use the Allen wrench supplied for this purpose. After having locked both stops on the two desired bending angle positions, you can quickly alternate the bending angles by simply moving the lever. The locking of the angles is valid for both right and left rotation.

7.2.6 Use of bending rollers and pins

On the turntable there are 3 holes for inserting the pins. The pin marked "C" must be inserted in the central hole. The use of the appropriate pins and rollers depends on the diameter of the rod to be bended. The pins or feeding rollers must be inserted in the holes "A" or "B". Between the rod to be bent and the pin/feeding roller there must be about 5 mm play, otherwise the rod can get stuck between the pins/rollers when the turntable returns to the zero position.

On the right and on the left side of the turntable there is a saddle "L" with holes for the insertion of the rod guide. The knurled knob "N" allows continuous adjustment. Adjust the rod guide "M" in order to keep the rod to be processed always parallel to the bench of the bending machine. If you want to achieve always the same bending angles, both on the right and on the left, you need to adjust the saddles evenly. After the good adjustment, lock the two saddles by means of two hexagonal-head screws. The rod guides are designed for the maximum diameter of every single type of bending machine and can be used accordingly. On request, you can also use thrust rollers with special pins marked "PC", to be inserted on the saddles.

7.3 Operation of the machine

7.3.1 Work position of the operator

The machine design allows the operator for working in front of the control board with the start, stop and emergency pushbuttons. We advise the operator not to use the machine on the side opposite to the control devices, except for the execution of stirrups.

7.3.2 Bending of stirrups

To carry out round spirals, rings and large bows a special attachment is supplied, which is equipped with a rule and two adjustable and tilting stops. The rule must be inserted on the right saddle. On the left saddle insert the rod guide. Adjust the rod guide in such a way as to keep the rod to be processed parallel to the bench. Insert in the central hole of the turntable the pin

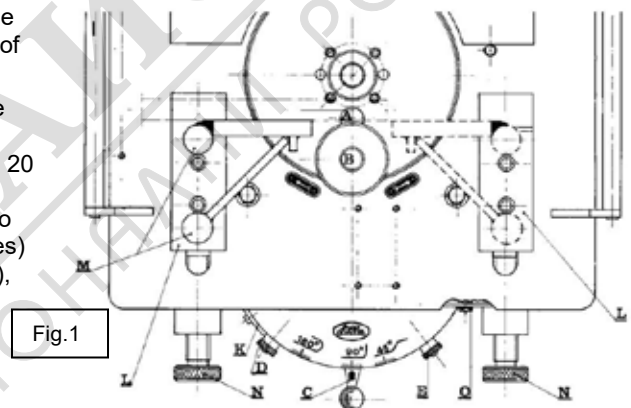

relevant to the rod diameter. Insert in hole "A" or in hole "B" a pin with a feeding roller. Ensure a play of about 5 mm between the brake and the roller. You can also simultaneously bend a certain number of rods in accordance with the diameter.

Should the rods, by any chance, get stuck between the roller and the bending pin, act as follows:

1. Reverse the running direction by means of the reversing gear placed on the switchboard.
2. Press the start push button immediately followed by the stop push button (necessary to carry out a small displacement in the direction opposite to that of work).
3. Remove the rods that got stuck.
4. Reset the initial working conditions. When pressing the start push button the machine will return to the initial working condition.

**ESECUZIONE
EXECUTION**

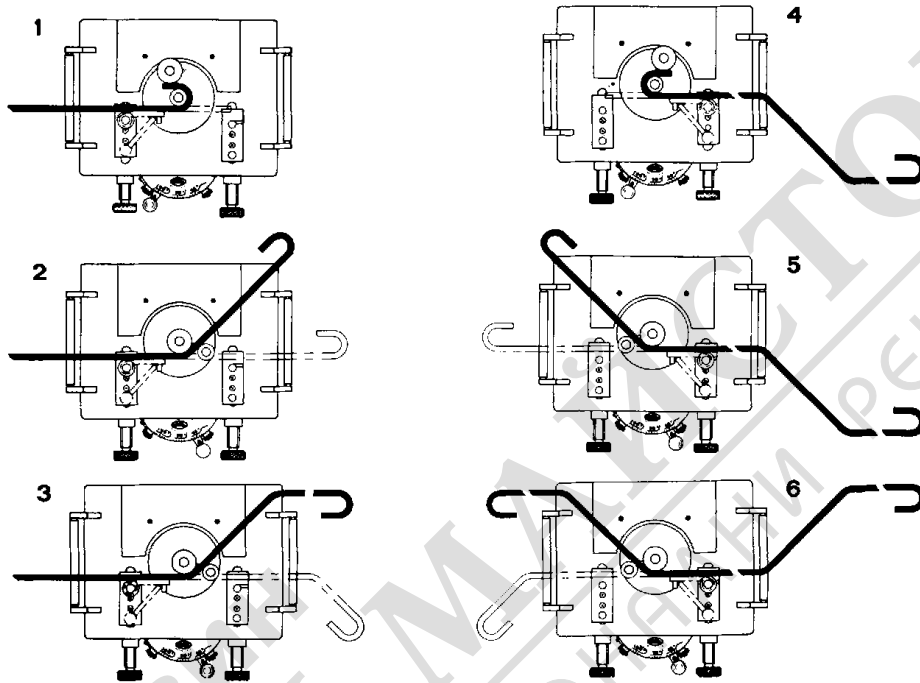

**2 - ESECUZIONE DI STAFFE E SPIRALI POLIGONALI
BENDING OF STIRRUPS AND POLYGONAL SPIRALS**



**ORDINE DI PIEGATURA
BENDING ORDER**

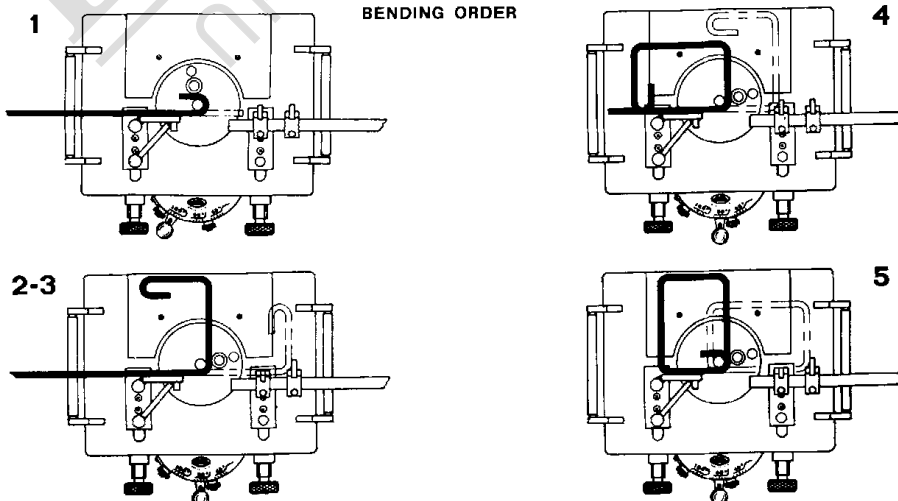

Keep the bending machine always switched off when you do not use it.

7.3.3 Procedure to be applied in case of accident

Should there occur a dangerous situation or in case of accident, immediately press the emergency stop push button in order to stop the machine.

The best weapon against accidents is and remains caution, full concentration and reflection on what you are going to do and its consequences.

7.3.4 During operation

- **Use the prescribed personal protective equipment.**
- Never approach the moving and operating elements with your hands, arms or other parts of your body. Remove rubble with an appropriate device and always when the machine is stopped: **never use your hands!**
- In case of machine trouble or inspections, never work when the machine is running; stop the machine and immediately disconnect it from the electric installation.
- During the operation of the machine, of its elements or of its accessories, it is strictly forbidden to remove any protection, like limit switches, carters, barriers or other protection and safety elements. Never modify switches or other safety and/or operating cycle control devices, because such an intervention could seriously damage the mechanical elements of the machine and injure the health of the operator.
- Pay attention to the operating and the moving parts.
- Do not climb or position yourself on or inside the machine, even if it is switched off.
- In case of machine trouble, stop the machine with the emergency stop push-button and cut off the electric energy supply until the trouble has been eliminated.

The operator is the person entitled to operate with the machine and consequently he is the only responsible for it.

7.3.4 Warning signs

See chap 4.1.2 page 5

1. **PIEGATURE STOP RITORNO**

2. **ARRESTO EMERGENZA**

3. **TENERE BEN OLIATO
KEEP WELL OILED
GARDER BIEN HUILÉ**

4. **ATTENZIONE!**
Prima di mettere in moto la macchina collegare la terra.
Controllare il senso di rotazione del disco come indicano le frecce.
Controllare che il motore e il trasformatore siano collegati con la tensione di linea.

5. **ACHTUNG! ATTENTION! ATTENTION!**
Motor ist eingestellt auf : Motor is connected to : Moteur branché sur :
380 volts

6. **Technical specifications label according to model (PS32 or PS36 or PS40 or PS45 or PS50 or PS55)**

7. **Warning sign: High Voltage (380V)**

8. **Warning sign: No Hand**

9. **Warning sign: Grounding symbol**

10. **Warning sign: Read manual**



8. MAINTENANCE

The bending machine does not require any particular maintenance work. The technical solutions and the components installed on the machine reduce maintenance at the minimum. However, we recommend to carry out a series of operations, which aim at ensuring safety, liability, efficiency and long life of the machine.

During maintenance

Before performing any maintenance work on the machine, disconnect the power cable from the machine. In case of mechanical or electric trouble, call the authorized personnel. If the machine is out of service because of trouble, maintenance or repair, place a special sign highlighting this status so as to avoid accidental starting.



- Always use the personal protective equipment (leather gloves of approved type, safety shoes, safety mask and safety goggles during repair and replacement of the machine elements.
- Repairs of the electric installation shall be done by authorized and specialized personnel only.
- Do not approach hands, arms or other parts of your body to the movement and transmission area. Use appropriate means (brush, wooden piece, etc.) to remove possible rubble: **never use your hands!**
- To ensure long life, prevent damage and ensure the full functioning of the mechanical and electric machine elements the maintenance must be performed regularly. Periodically check the earthing system, according to the laws in force.
- Before starting the machine, ensure there are no tools or foreign matters left inside or on the machine.

8.1 Recommended lubricants

MINERAL OIL			
	23°E at 50°C - 320 cSt at 40°C	32°E at 50°C - 460cSt at 40°C	
WORM REDUCTION UNITS	MELLANA OIL 320	MELLANA OIL 460	IP
	SPARTAN EP 320	SPARTAN EP 460	ESSO
	BLASIA 320	BLASIA 460	AGIP
	MOBILGEAR 632	MOBILGEAR 634	MOBIL
	OMALA 320	OMALA 460	SHELL
	ENERGOL GR-XP 320	ENERGOL GR-XP 460	BP
SYNTHETIC GREASE			
REDUCTION GEARS AND WORM RED. UNITS	TELESIA COMPOUND B		IP
	STRUCTOVIS P LIQUID		KLUBER
	TIVELA COMPOUND A		SHELL
SYNTHETIC OIL			
REDUCTION GEARS AND WORM RED. UNITS	TIVELA OIL WB		SHELL
	SYNTHESO D 220 EP		KLUBER
	BLASIA S 220		AGIP

GREASE						
	MAKE	TYPE	PENETR.	DRIP	1 st LUBRIC.	FOLL. LUBR.
LUBRIC. AND VARIOUS GEARS	ESSO	BEACON EP2	265/295	182	100	300

8.2 Ordinary maintenance

To be carried out every day at the end of the work. To be carried out every week at the end of the work.

A) DAILY CLEANING AND MAINTENANCE

Stop the bending machine and cut off the electric energy supply, then remove material residuals and deposits from:

- turntable
- bending rollers and pins-
- work table

Caution!! Do not wash the electric parts with high-pressure water jets.

B) WEEKLY CLEANING AND MAINTENANCE

At the end of the week, after the cleaning of the bending machine as explained above, provide for:

- Check tightening of clamping screws of main machine elements:
- Check the lubricant level inside the reduction gear case through the transparent plug placed on the case; the oil must be visible through this plug after at least ten minutes from machine stop. In case of low lubricant level, add the necessary quantity of the recommended oil type (see recommended lubricant schedule) through the filling cap.
- Grease by means of the grease nipple, placed on the right of the special device for pre-setting the bending angle, the sliding block (item 16 tab. 3).
- Check the lubrication schedule for programmed oil change of reduction gear, and carry out oil change, if necessary.
- Check tightening and integrity of all the V-belts of the bending machine.
- Lubricate all the parts, which are not protected by means of painting.
- Adjust and replace wherever necessary.

Oil is a special waste and must be disposed of according to the laws in force.



IMPORTANT : Daily and weekly checks are very important to prevent machine troubles. In fact, whenever during these checks you will find some worn or damaged components, immediately order the relevant spare parts to be kept on stock, before the component has definitively broken with consequent production stop.

8.3 Extraordinary maintenance

- Check the safety of the electric system: isolation of cables, working of differential protection device, continuity of protection wire, working of safety limit switch on guards/protections.
- Check interlocks of mechanical components.
- Change the lubricants according to the lubrication schedule intervals.

Note * -The V-belts must be immediately replaced whenever a defect is detected.

8.4 Bolt torque. Tightening is executed by means of dynamometric wrenches, according to the torques shown in the following pages and in the tables shown below:

LARGE PITCH			SMALL PITCH		
Diameter screw x pitch	Torque wrench setting Kgm nut	Torque wrench setting Kgm screw	Diameter screw x pitch	Torque wrench setting Kgm nut	Torque wrench setting Kgm screw
6 x 1	1,1	1,2	8 x 1	2,7	1,2
8 x 1,25	2,6	2,8	10 x 1,25	5,5	2,8
10 x 1,5	5,1	5,6	12 x 1,25	9,7	5,6
12 x 1,75	8,9	9,7	14 x 1,50	15,3	9,7
14 x 2	14,1	15,5	16 x 1,50	23	15,5
16 x 2	21,5	23,6	18 x 1,50	33	23,6
18 x 2,5	29,5	32	20 x 1,50	46	32
20 x 2,5	42	46	22 x 1,50	62	46
22 x 2,5	57	62,5	24 x 2	79	62,5
24 x 3	72,5	79,5	27 x 2	115	79,5
27 x 3	107	117	30 x 2	160	117
30 x 3,5	145	159			

8.5 Troubleshooting

PROBLEM	CAUSE	SOLUTION
The machine does not run	No or low power in the supply line. The electric plug and socket are not properly connected. The cable from the plug to the electric panel is broken. A wire has become disconnected inside the panel. A wire has become disconnected on the terminal board. The switch is faulty. Intervention of a thermal protection. Tripped fuse.	Check supply line and voltage. Make a proper connection. Replace the cable. Remake the connection. Remake the connection. Replace the switch. Wait some minutes and try again. Change fuse.



For all other kinds of troubles, please refer to the After-Sales Dept. of the Company SILLA. CAUTION!!!! SILLA DECLINE ANY RESPONSIBILITY IN CASE THE MACHINE DOES NOT UNDERGO MAINTENANCE AS PRESCRIBED IN THIS INSTRUCTION MANUAL AND IN CASE OF USE OF SPARE PARTS AND ACCESSORIES OTHER THAN ORIGINAL AND NOT APPROPRIATE.

8.6 Ordering spare parts

When ordering spare parts, order the component from the supplier and/or manufacturer of the machine. Always mention the machine model, part number, type of machine, description of the desired component, quantity and the main features.



9. DISMANTLING

Before long-term storage (e.g. holidays), follow the instructions below:

1. Carefully clean the whole machine, remove dust, deposits and dirt.
2. Oil all the parts exposed to seizure and the mechanical components exposed to oxidation.
3. Store the machine in a dry and ventilated place.
4. Remove the patch cords and whatsoever to prevent unauthorized persons from using the machine.

9.1 Disassembling / dismantling

The bending machine can be dismantled and scrapped without the need to follow special prescriptions. However, it is necessary to remove the oil from the reduction gear, the plastic and rubber parts (cables, covers, etc.) and dispose of through specialised companies.

9.2 Disposal

The following are the materials the machine is made of:

- Painted steel, aluminium and other metallic components.
- Plastic materials.
- Oil-hydraulic materials
- Electric cables, electric components, electric motor.
- Oil



These materials must be disposed of through specialised companies in accordance with current laws in the country of use.

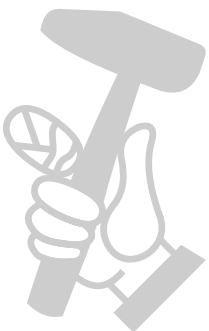

DECLARATION OF CONFORMITY



SILLA Macchine Edili e Stradali Srl

Via S.Gimignano , 96 - 53036 – POGGIBONSI (SI) – ITALY

In the person of Mr Neri Angiolo as Legal Representative
declare

under their sole responsibility that the machine:

GENERIC NAME	BENDING MACHINE
FUNCTION	BENDING OF REINFORCED CONCRETE RODS
MODEL	PS
TYPE	
SERIAL NUMBER	
TRADE NAME	...

complies with the essential requirements of the directives of the European Parliament and of the Council:

- “Machines 2006/42/CE published in O.G.E.U. on June 9, 2006.
- “Electromagnetic compatibility” 2004/108/CE published in O.G.E.U. on December 31, 2004

Furthermore it is declared that the machine has been designed and built according to the following harmonised standards:

- EN ISO 12100-1 (2003) Safety of machinery - basic concepts, general principles of design - Part 1: basic terminology, methodology,
- EN ISO 12100-2 (2003) Safety of machinery - basic concepts, general principles of design - Part 2: specifications and technical principles
- EN ISO 14121-1 (2007) Safety of machinery – risk evaluation -Part 1: principles
- EN 60204-1 (2006) Safety of machinery - electric system of the machine – Part 1: general rules
- EN ISO 13857 (2008) Safety of machinery - safety distances to prevent the upper and lower limbs from attaining dangerous areas
- EN ISO 13850 (2008) Safety of machinery – emergency stop – principles of design.
- EN ISO 13849-1 (2008) Safety of machinery - parts of the control systems concerning safety -Part 1: general principles of design one
- EN ISO 13849-2 (2008) Safety of machinery - parts of the control systems concerning safety -Part 2: validation

The legal person entitled to form the technical dossier and that has custody of the technical documents is

SILLA Macchine Edili e Stradali Srl

Via S.Gimignano , 96 - 53036 – POGGIBONSI (SI) – ITALY

Poggibonsi, date

Signature

МАГАЗИН
БАШ МАЙСТОРА®
ПРОФЕСИОНАЛНИ РЕШЕНИЯ

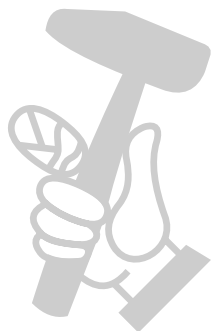

11. WARRANTY REGISTRATION FORM

Machine type	Part number 
--------------	---

IMPORTANT

This form must be filled out and stamped by the Dealer at the time of purchase of the machine. The Dealer or the buyer must send this form by registered mail to the After-Sales Dept. of the Company SILLA within 3 days from the purchase, together with a copy of the delivery note or of the invoice.

The mailing of this form, together with a copy of the transport document or a copy of the invoice, is an essential requirement to start warranty period. The warranty is void if not registered

Date

Stamp and Signature of the Dealer

Messrs.

SILLA Macchine Edili e Stradali Srl

Via S.Gimignano , 96 - 53036 – POGGIBONSI (SI) – ITALIA

11.1 WARRANTY CONDITIONS

Warranty means the repair and/or the replacement of those parts, which are proven to be defective in manufacture. The replacement of the whole machine is excluded.

The warranty is for the period of 1 year from the date of delivery to the user, that is to say the date written in the Warranty Registration Form.

The defective materials must be sent, free delivered, to our factory. After technical approval the material will be replaced and sent carriage forward.

The warranty expires in case of:

- modifications, repairs, alterations of the machine carried out by the buyer and not expressly authorised by SILLA.
- improper assembling or failure to use the machine according to the instructions of the instruction manual.
- The electric components are not covered by this warranty, because a wrong connection done by the user and/or line problems may cause damage to these components.
- Any repair under warranty will not interrupt the warranty period.

- **We recommend to the dealers to write the part number of the Bending Machine both on the delivery note and on the invoice.**

МАГАЗИН
БАШ МАЙСТОРА[®]
ПРОФЕСИОНАЛНИ РЕШЕНИЯ

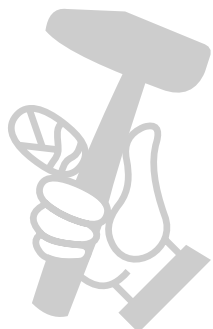

PS32 PS36

“I”

-

RICAMBI

“GB”

-

SPARE PARTS

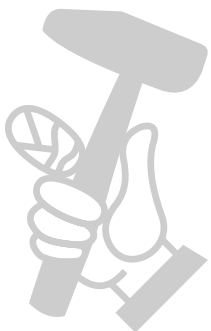

	Tav.01	Tav.01	Gruppo telaio e scatola riduttore	Frame group and Adapter box
	PS32	PS36	I	GB
Rif	Codice	Codice		
1	PS32.01.001	PS36.01.001	Telaio	Frame
2	PS32.01.002	PS36.01.002	Ruota anteriore (160/40/80)	Wheel
3	PS32.01.003	PS36.01.003	Ruota posteriore (200/50/100)	Wheel
4	PS32.01.004	PS36.01.004	Scatola riduttore con coperchio	Adapter box with cap
6	PS32.01.006	PS36.01.006	Albero d'uscita	Exit shaf
7	PS32.01.007	PS36.01.007	Disco	Disc
8	PS32.01.008	PS36.01.008	Spina	Plug
9	PS32.01.009	PS36.01.009	Vite M8x45 TCCE	M8x45 TCCE Screw
10	PS32.01.010	PS36.01.010	Corona dentata	Ferrule
11	PS32.01.011	PS36.01.011	Porta corona	Ferrule support
12	PS32.01.012	PS36.01.012	Seeger	Seeger
13	PS32.01.013	PS36.01.013	Linguetta 18x11x35	Tongue
14	PS32.01.014	PS36.01.014	Cuscinetto	Bearing
15	PS32.01.015	PS36.01.015	Cuscinetto	Bearing
16	PS32.01.016	PS36.01.016	Seeger	Seeger
17	PS32.01.017	PS36.01.017	Seeger	Seeger
18	PS32.01.018	PS36.01.018	Supporto motore	Motor support
19	PS32.01.019	PS36.01.019	Perno	Pin
20	PS32.01.020	PS36.01.020	Rondella	Washer
21	PS32.01.021	PS36.01.021	Boccola isolante	Sleeve
22	PS32.01.022	PS36.01.022	Leva tenditore	Extender bar
23	PS32.01.023	PS36.01.023	Sfera Ø 30	Sphere Ø 30
24	PS32.01.024	PS36.01.024	Manicotto tendicinghie	Extender
25	PS32.01.025	PS36.01.025	Tirante destro	Right connectin rod
26	PS32.01.026	PS36.01.026	Tirante sinistro	Left connecting rod
27	PS32.01.027	PS36.01.027	Perno per tenditore	Pin
28	PS32.01.028	PS36.01.028	Vite con Dado	Screw with nut
29	PS32.01.029	PS36.01.029	Piano	Table
30	PS32.01.030	PS36.01.030	Rullo scorrimento barre	Bars sliding
31	PS32.01.031	PS36.01.031	Vite posizionamento slitte	Positionment screw
32	PS32.01.032	PS36.01.032	Slitta superiore sinistra	Up left guide
33	PS32.01.033	PS36.01.033	Slitta inferiore sinistra	Down left guide
34	PS32.01.034	PS36.01.034	Rondella filettata	Washer
35	PS32.01.035	PS36.01.035	Boccola	Sleeve
36	PS32.01.036	PS36.01.036	Motore elettrico frenante 4 HP	Self breaking engine 4HP
37	PS32.01.037	PS36.01.037	Cinghia	Strap
38	PS32.01.038	PS36.01.038	Spina 16 Amp.	16 Amp. Plug
39	PS32.01.039	PS36.01.039	Pres a comando a pedale	Pedal plug
40	PS32.01.040	PS36.01.040	Sportello	Shutter
41	PS32.01.041	PS36.01.041	Manopola sportello	Handle
42	PS32.01.042	PS36.01.042	Carter protezione	Protection carter
43	PS32.01.043	PS36.01.043	Slitta superiore destra	Up right guide
44	PS32.01.044	PS36.01.044	Slitta inferiore destra	Down right guide
45	PS32.01.045	PS36.01.045	Puleggia conduttrice	Pulley
46	PS32.01.046	PS36.01.046	Linguetta	Tongue
47	PS32.01.047	PS36.01.047	Vite senza fine	Screw without end
48	PS32.01.048	PS36.01.048	Pres a elettrica	Electric socket
49	PS32.01.049	PS36.01.049	Spina elettrica	Electric plug
50	PS32.01.049	PS36.01.050	Pedali era	Pedal Foot

TAV. 1 GRUPPO TELAIO E SCATOLA RIDUTTORE
BENDING MACHINE ASSEMBLY

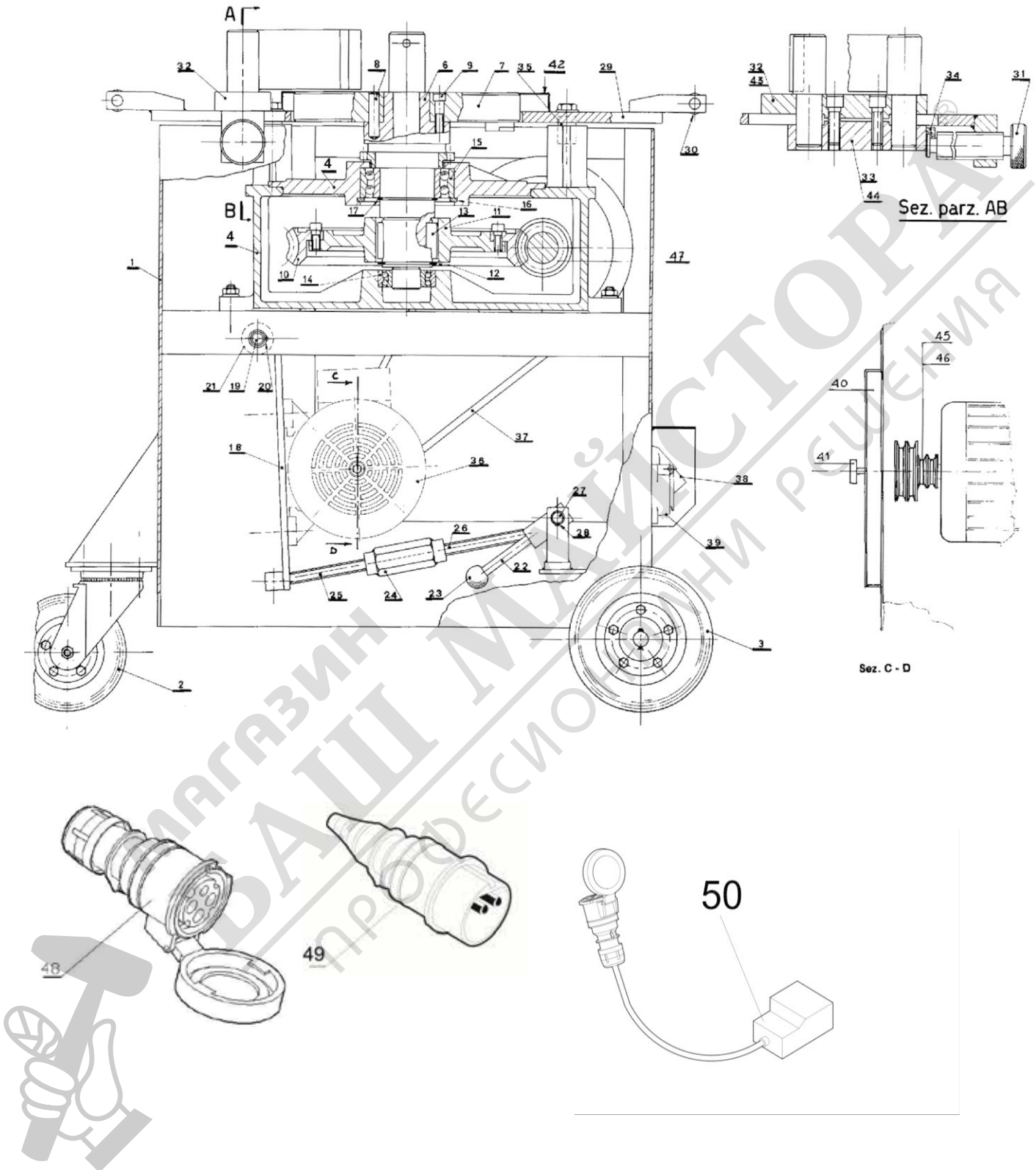

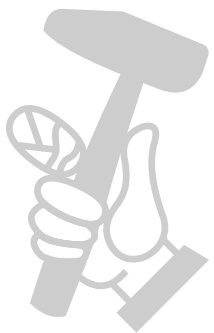

МАГАЗИН
БАШ МАЙСТОРА®
ПРОФЕСИОНАЛНИ РЕШЕНИЯ

	Tav.02	Tav.02	Gruppo vite senza fine	Screw group
	PS32	PS36	I	GB
Rif	Codice	Codice		
1	PS32.02.001	PS36.02.001	Puleggia condotta	Pulley
2	PS32.02.002	PS36.02.002	Linguetta	Tongue
3	PS32.02.003	PS36.02.003	Vite senza fine	Screw without end
4	PS32.02.004	PS36.02.004	Dado	Nut
5	PS32.02.005	PS36.02.005	Distanziale	Spacer
6	PS32.02.006	PS36.02.006	Guarnizione OR 4100-133	Packing OR 4100-133
7	PS32.02.007	PS36.02.007	Guarnizione MIM 304410	Packing MIM 304410
8	PS32.02.008	PS36.02.008	Guarnizione OR 168	Packing OR 168
9	PS32.02.009	PS36.02.009	Cuscinetto 6005	Bearing
10	PS32.02.010	PS36.02.010	Boccola posteriore	Back buckle
11	PS32.02.011	PS36.02.011	Anello filettato	Ring
12	PS32.02.012	PS36.02.012	Cuscinetto 52206X	Bearing
13	PS32.02.013	PS36.02.013	Distanziale	Spacer
14	PS32.02.014	PS36.02.014	Supporto flangiato	Support
15	PS32.02.015	PS36.02.015	Guarnizione OR 174	Packing OR 174
16	PS32.02.016	PS36.02.016	Cuscinetto 1206	Bearing
17	PS32.02.017	PS36.02.017	Seeger I 62	Seeger

**TAV. 2 GRUPPO VITE SENZA FINE
WORM GEAR ASSEMBLY**

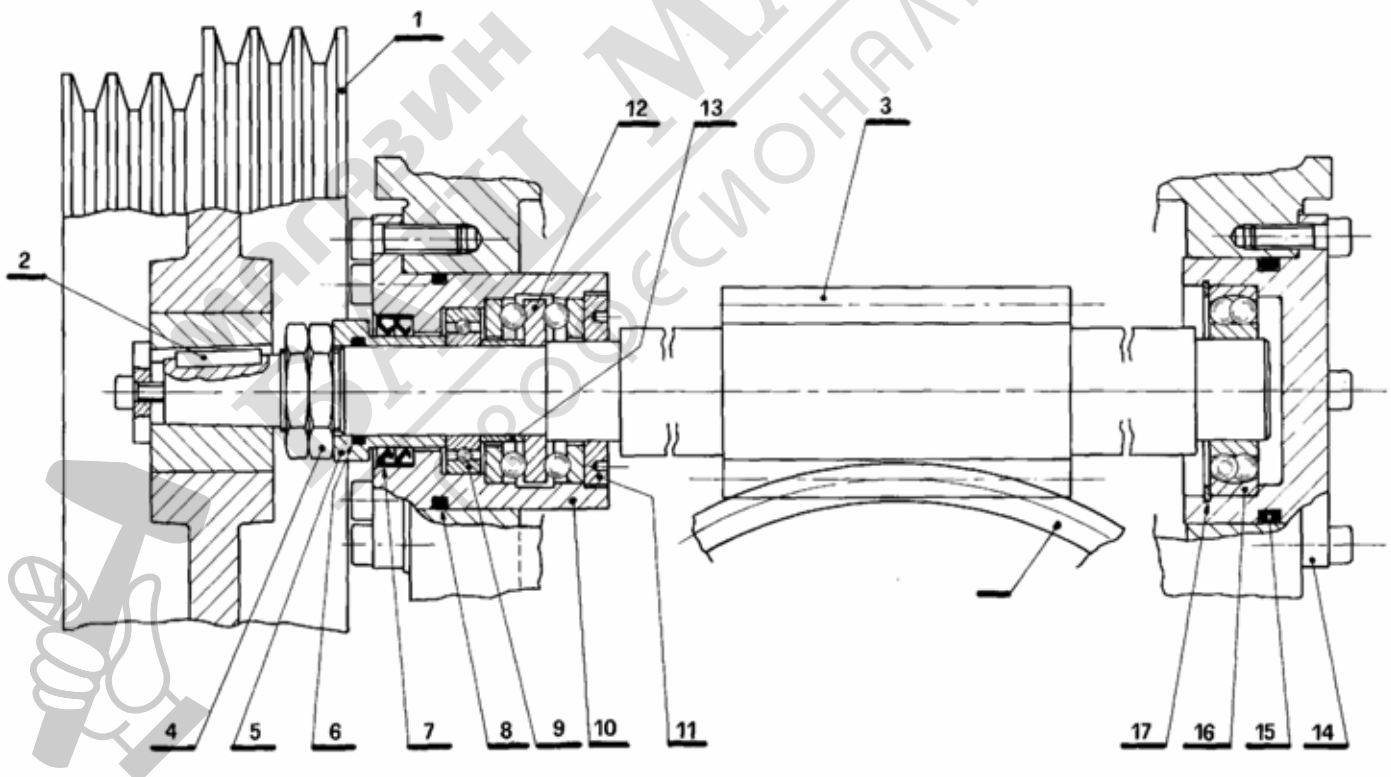

	Tav.03	Tav.03	Dispositivo regolazione angolo piegatura	Banding angle Regulation
	PS32	PS36	I	GB
Rif	Codice	Codice		
1	PS32.03.001	PS36.03.001	Ingranaggio conduttore	Conduction Gear
2	PS32.03.002	PS36.03.002	Ingranaggio condotto	Conducted gear
3	PS32.03.003	PS36.03.003	Perno flangiato	Pivot
4	PS32.03.004	PS36.03.004	Bronzina	Bearing
5	PS32.03.005	PS36.03.005	Seeger E 20	E20 Seeger
6	PS32.03.006	PS36.03.006	Camma	Camshaft
7	PS32.03.007	PS36.03.007	Bilanciere	Balance Wheel
8	PS32.03.008	PS36.03.008	Bronzina bilanciere	Balance wheel bearing
9	PS32.03.009	PS36.03.009	Supporto bilanciere	Balance Wheel support
10	PS32.03.010	PS36.03.010	Seeger E 15	Seeger
11	PS32.03.011	PS36.03.011	Molla	Spring
12	PS32.03.012	PS36.03.012	Perno	Pivot
13	PS32.03.013	PS36.03.013	Cuscinetto 608 E	608 E Pad
14	PS32.03.014	PS36.03.014	Supporto cursore	Support
15	PS32.03.015	PS36.03.015	Spina elastica Ø 4,5x25	Elastic plug Ø 4,5x25
16	PS32.03.016	PS36.03.016	Cursore	Cursor
17	PS32.03.017	PS36.03.017	Bronzina	Bearing
18	PS32.03.018	PS36.03.018	Sfere cursore	Cursor spheres
19	PS32.03.019	PS36.03.019	Molla	Spring
20	PS32.03.020	PS36.03.020	Perno	Pivot
21	PS32.03.021	PS36.03.021	Vite TCCE M4x15	TCCE M4x15 Screw
22	PS32.03.022	PS36.03.022	Supporto finecorsa bilanciere	Support
23	PS32.03.023	PS36.03.023	Interruttore di finecorsa	Switch
24	PS32.03.024	PS36.03.024	Supporto finecorsa disco	Support
25	PS32.03.025	PS36.03.025	Battuta finecorsa disco	Beating
26	PS32.03.026	PS36.03.026	Leva regolazione piegature	Regulation bar
27	PS32.03.027	PS36.03.027	Seeger E 10	E10 Seeger
28	PS32.03.028	PS36.03.028	Sfera Ø 30	Sphere Ø 30
29	PS32.03.029	PS36.03.029	Boccola	Buckle
30	PS32.03.030	PS36.03.030	Supporto settore graduato	Support
31	PS32.03.031	PS36.03.031	Settore graduato	Graduated sector
32	PS32.03.032	PS36.03.032	Piastrina	Plate
33	PS32.03.033	PS36.03.033	Battuta scorrevole	Sliding Beating
34	PS32.03.034	PS36.03.034	Porta ingrassatore cursore	Lubrificator rack
35	PS32.03.035	PS36.03.035	Tubo lubrificazione cursore	Cursor lubrication pipe
36	PS32.03.036	PS36.03.036	Ingrassatori a 90° M6	Lubrificators

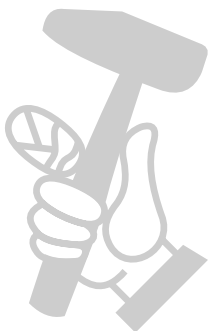

TAV. 3 DISPOSITIVO REGOLAZIONE ANGOLO DI PIEGATURA
BENDING ANGLE CONTROL DEVICE

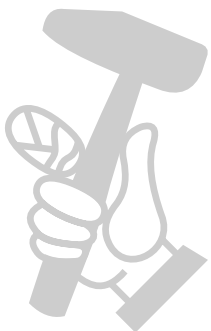
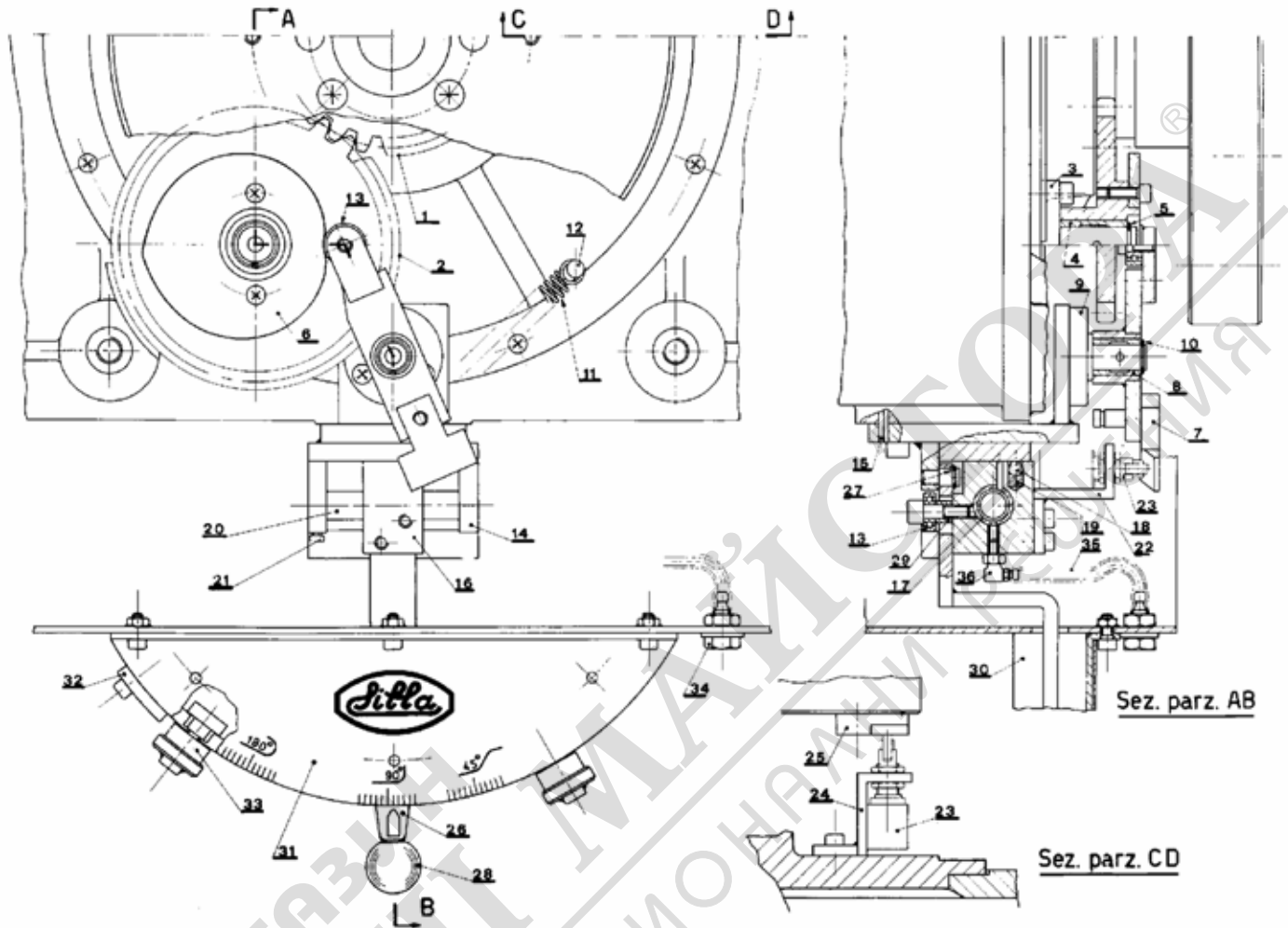

	Tav.04	Tav.04	Serie completa di perni e boccole	Complete range of Pivots and buckles
	PS32	PS36	I	GB
Rif	Codice	Codice		
1	PS32.04.001	PS36.04.001	Perno centrale (Ø25/32- Ø25/36)	Centre Pivot (Ø25/32- Ø25/36)
2	PS32.04.002	PS36.04.002	Perno centrale (Ø35/32- Ø38/36)	Centre Pivot (Ø35/32- Ø38/36)
3	PS32.04.003	PS36.04.003	Perno centrale (Ø44/32- Ø44/36)	Centre Pivot (Ø44/32- Ø44/36)
4	PS32.04.004	PS36.04.004	Perno centrale (Ø55/32- Ø55/36)	Centre Pivot (Ø55/32- Ø55/36)
6	PS32.04.006	PS36.04.006	Perno laterale (Ø35/32- Ø38/36)	Lateral Pivot (Ø35/32- Ø38/36)
7	PS32.04.007	PS36.04.007	Perno laterale (Ø45/32- Ø50/36)	Lateral Pivot (Ø45/32- Ø50/36)
8	PS32.04.008	PS36.04.008	Perno laterale (Ø50/32- Ø55/36)	Lateral Pivot (Ø50/32- Ø55/36)
10	PS32.04.010	PS36.04.010	Boccole (Ø70/32- Ø80/36)	Buckles (Ø70/32- Ø80/36)
11	PS32.04.011	PS36.04.011	Boccole (Ø80/32- Ø95/36)	Buckles (Ø80/32- Ø95/36)
12	PS32.04.012	PS36.04.012	Boccole (Ø90/32- Ø105/36)	Buckles (Ø90/32- Ø105/36)
13	PS32.04.013	PS36.04.013	Boccole (Ø115/32- Ø130/36)	Buckles (Ø115/32- Ø130/36)

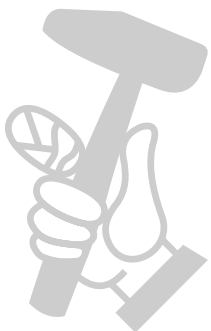
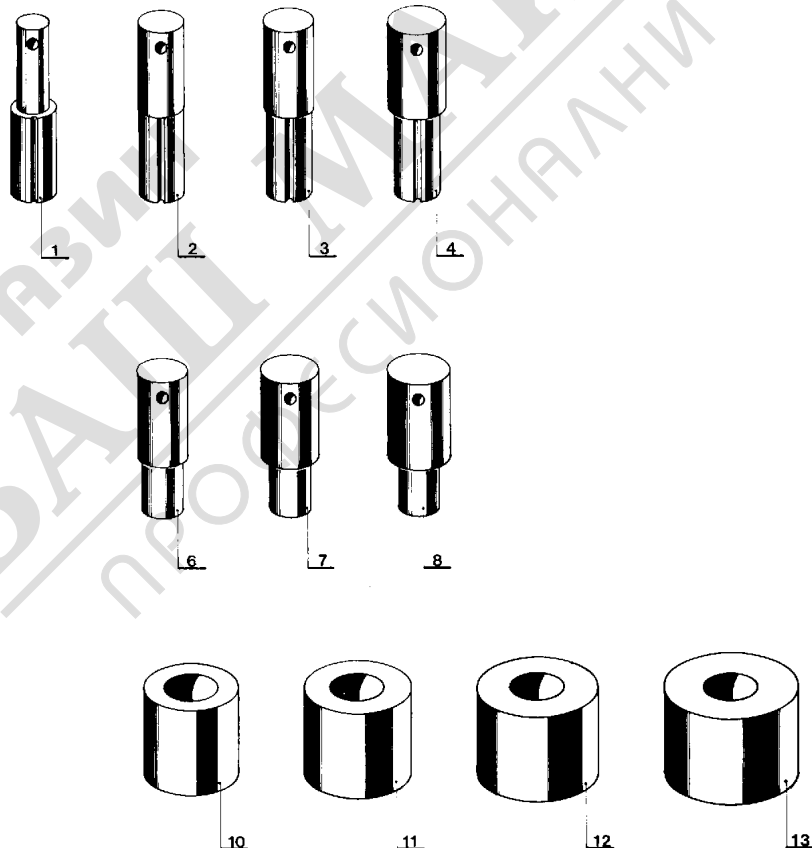

	Tav.05	Tav.05	Accessori per staffatura	Accessories
	PS32	PS36	I	GB
Rif	Codice	Codice		
1	PS32.05.001	PS36.05.001	Asta appoggio staffe	Brace
2	PS32.05.002	PS36.05.002	Piastra di fissaggio battuta	Fixing plate
3	PS32.05.003	PS36.05.003	Cerniera per battuta	Hasp
4	PS32.05.004	PS36.05.004	Spina elastica	Elastic plug
5	PS32.05.005	PS36.05.005	Battuta retrattile	Beating
6	PS32.05.006	PS36.05.006	Vite	Screw
7	PS32.05.007	PS36.05.007	Rondella	Washer
8	PS32.05.008	PS36.05.008	Contrasto appoggio barre	Support contrast
9	PS32.05.009	PS36.05.009	Appoggio barre	Bars support

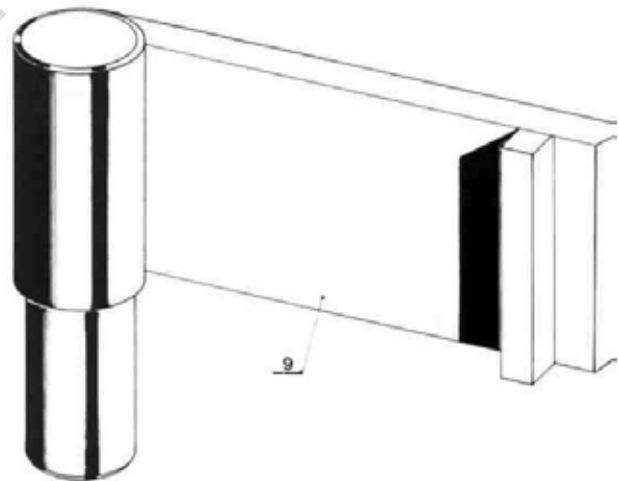
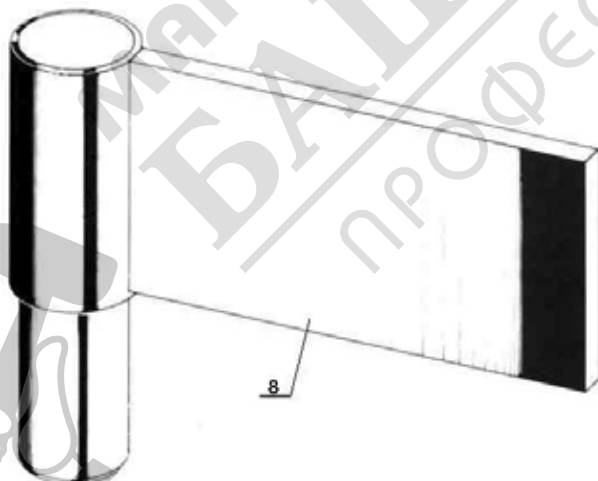
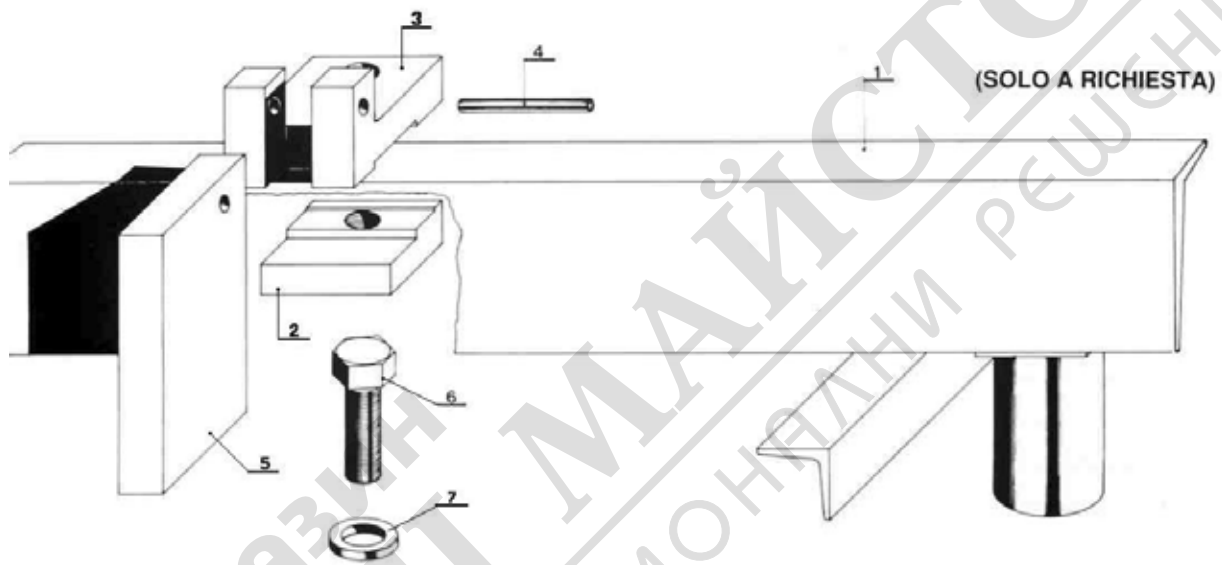

	Tav.06	Tav.06	Cassetta comandi elettrici	Electrical drive box
	PS32	PS36	I	GB
Rif	Codice	Codice		
1	PS32.06.001	PS36.06.001	Cassetta elettrica completa	Complete box
2	PS32.06.002	PS36.06.002	Pannello isolante	Insulating panel
3	PS32.06.003	PS36.06.003	Teleruttori 16 Amp.	Teleruptors
4	PS32.06.004	PS36.06.004	Morsettiera	Clamps box
5	PS32.06.005	PS36.06.005	Trasformatore 50 VAR	Transormer
6	PS32.06.006	PS36.06.006	Scheda elettronica	Electronic CArd
7	PS32.06.007	PS36.06.007	Salvamotore	Engine saver
8	PS32.06.008	PS36.06.008	Blocco porta	Door block
12	PS32.06.012	PS36.06.012	Pressa cavo	Cable press
13	PS32.06.013	PS36.06.013	Pulsante di ritorno	Return switch (green)
14	PS32.06.014	PS36.06.014	Pulsante di arresto (rosso)	Stop switch (read)
15	PS32.06.015	PS36.06.015	Pulsante di piegatura	Bending switch (black)
16	PS32.06.016	PS36.06.016	Spia	Light
17	PS32.06.017	PS36.06.017	Commutatore di linea	Line changer

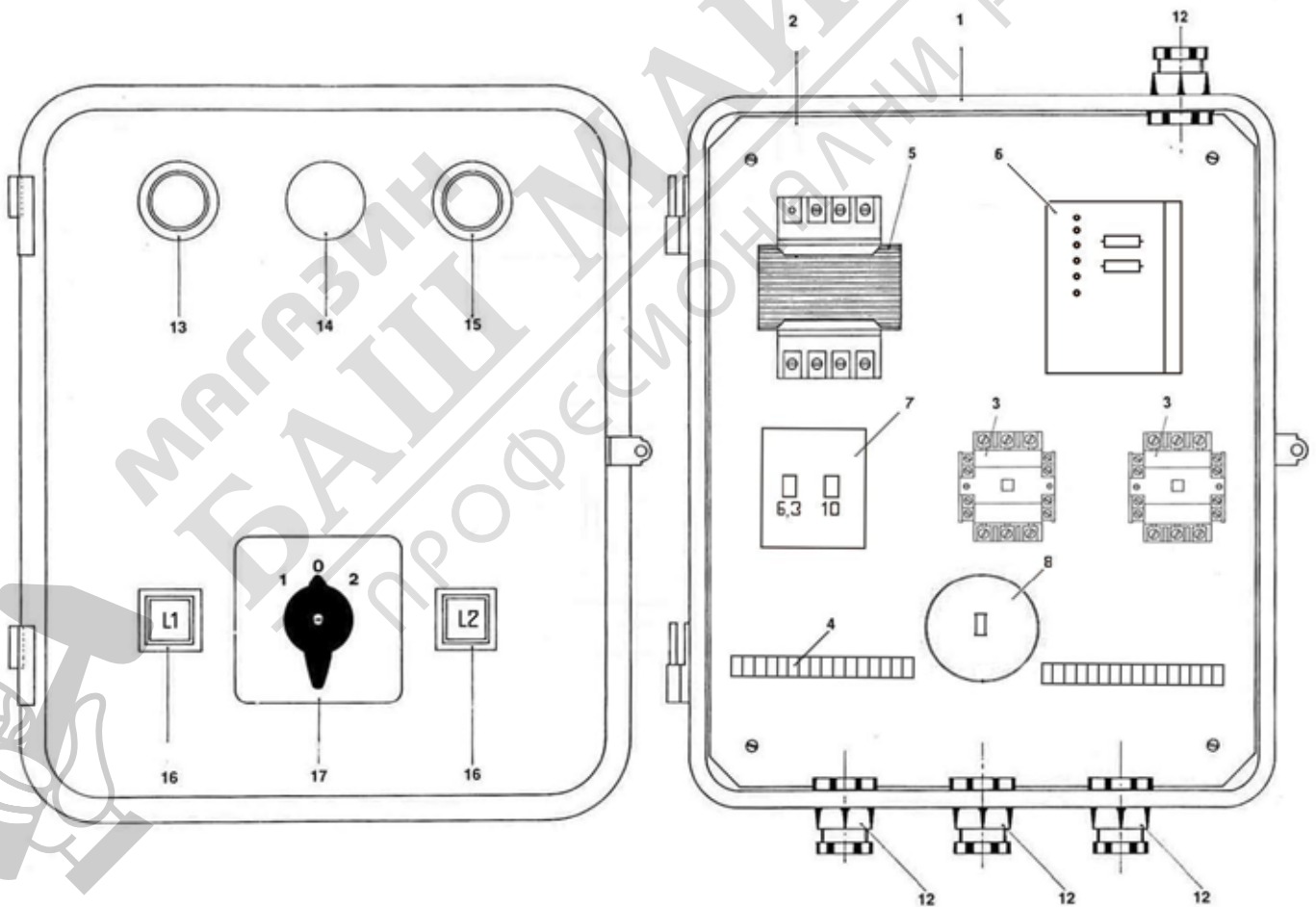

PS40 – 45 – 50 – 55

“I”

-

RICAMBI

“GB”

-

SPARE PARTS

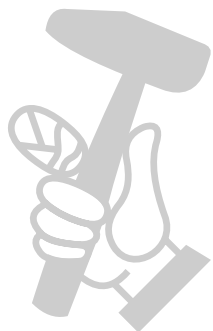

	Tav.01	Tav.01	Tav.01	Tav.01	Gruppo telaio e scatola riduttore	Frame group and adapter box
	PS40	PS45	PS50	PS55	I	GB
Rif	Codice	Codice	Codice	Codice		
1	PS40.01.001	PS45.01.001	PS50.01.001	PS55.01.001	Telaio	Frame 
2	PS40.01.002	PS45.01.002	PS50.01.002	PS55.01.002	Ruota	Wheel
4	PS40.01.004	PS45.01.004	PS50.01.004	PS55.01.004	Scatola riduttore con coperchio	Adapter box with cap
6	PS40.01.006	PS45.01.006	PS50.01.006	PS55.01.006	Albero d'uscita	Exit bar
7	PS40.01.007	PS45.01.007	PS50.01.007	PS55.01.007	Albero intermedio	Intermediate shaft
8	PS40.01.008	PS45.01.008	PS50.01.008	PS55.01.008	Cuscinetto	Pad
9	PS40.01.009	PS45.01.009	PS50.01.009	PS55.01.009	Cuscinetto	Pad
10	PS40.01.010	PS45.01.010	PS50.01.010	PS55.01.010	Cuscinetto	Pad
11	PS40.01.011	PS45.01.011	PS50.01.011	PS55.01.011	Cuscinetto	Pad
12	PS40.01.012	PS45.01.012	PS50.01.012	PS55.01.012	Ingranaggio	Gear
13	PS40.01.013	PS45.01.013	PS50.01.013	PS55.01.013	Pignone	Pinion
14	PS40.01.014	PS45.01.014	PS50.01.014	PS55.01.014	Disco	Disc
15	PS40.01.015	PS45.01.015	PS50.01.015	PS55.01.015	Spina	Plug
16	PS40.01.016	PS45.01.016	PS50.01.016	PS55.01.016	Vite	Screw
17	PS40.01.017	PS45.01.017	PS50.01.017	PS55.01.017	Anello seeger	Seeger ring
18	PS40.01.018	PS45.01.018	PS50.01.018	PS55.01.018	Linguetta	Tongue
19	PS40.01.019	PS45.01.019	PS50.01.019	PS55.01.019	Anello seeger	Seeger ring
20	PS40.01.020	PS45.01.020	PS50.01.020	PS55.01.020	Anello seeger	Seeger ring
21	PS40.01.021	PS45.01.021	PS50.01.021	PS55.01.021	Corona dentata	Ferrule
22	PS40.01.022	PS45.01.022	PS50.01.022	PS55.01.022	Linguetta	Tongue
23	PS40.01.023	PS45.01.023	PS50.01.023	PS55.01.023	Tappo	Cap
24	PS40.01.024	PS45.01.024	PS50.01.024	PS55.01.024	Protezione	Protection
25	PS40.01.025	PS45.01.025	PS50.01.025	PS55.01.025	Distanziale	Spacer
26	PS40.01.026	PS45.01.026	PS50.01.026	PS55.01.026	Puleggia	Pulley
27	PS40.01.027	PS45.01.027	PS50.01.027	PS55.01.027	Puleggia	Pulley
28	PS40.01.028	PS45.01.028	PS50.01.028	PS55.01.028	Piastra motore	Engine plate
29	PS40.01.029	PS45.01.029	PS50.01.029	PS55.01.029	Perno	Pivot
30	PS40.01.030	PS45.01.030	PS50.01.030	PS55.01.030	Anello seeger	Seeger ring
31	PS40.01.031	PS45.01.031	PS50.01.031	PS55.01.031	Boccola	Buckle
32	PS40.01.032	PS45.01.032	PS50.01.032	PS55.01.032	Piano	Table
33	PS40.01.033	PS45.01.033	PS50.01.033	PS55.01.033	Boccola	Buckle
34	PS40.01.034	PS45.01.034	PS50.01.034	PS55.01.034	Vite	Screw
35	PS40.01.035	PS45.01.035	PS50.01.035	PS55.01.035	Slitta sup.sx	Up. Right guide
35A	PS40.01.035A	PS45.01.035A	PS50.01.035A	PS55.01.035A	Slitta sup.dx	Up. Left guide
36	PS40.01.036	PS45.01.036	PS50.01.036	PS55.01.036	Slitta inf.sx	Down Right guide
36A	PS40.01.036A	PS45.01.036A	PS50.01.036A	PS55.01.036A	Slitta inf.dx	Down left guide
37	PS40.01.037	PS45.01.037	PS50.01.037	PS55.01.037	Rondella	Washer
38	PS40.01.038	PS45.01.038	PS50.01.038	PS55.01.038	Catrer	Carter
39	PS40.01.039	PS45.01.039	PS50.01.039	PS55.01.039	Motore	Engine
40	PS40.01.040	PS45.01.040	PS50.01.040	PS55.01.040	Cinghia	Strap
41	PS40.01.041	PS45.01.041	PS50.01.041	PS55.01.041	Spina 16A	16° Plug
42	PS40.01.042	PS45.01.042	PS50.01.042	PS55.01.042	Presa pedale	Pedal plug
48	PS40.01.048	PS45.01.048	PS50.01.048	PS55.01.048	Presa elettrica	Electric socket
49	PS40.01.049	PS45.01.049	PS50.01.049	PS55.01.049	Spina elettrica	Electric plug
50	PS40.01.050	PS45.01.050	PS50.01.050	PS55.01.049	Pedaliera	Pedal Foot

TAV. 1 GRUPPO TELAIO E SCATOLA RIDUTTORE
BENDING MACHINE ASSEMBLY

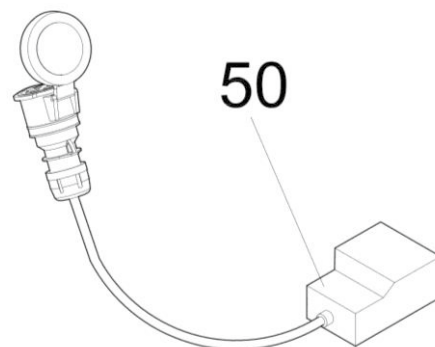
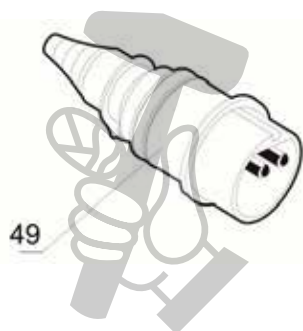
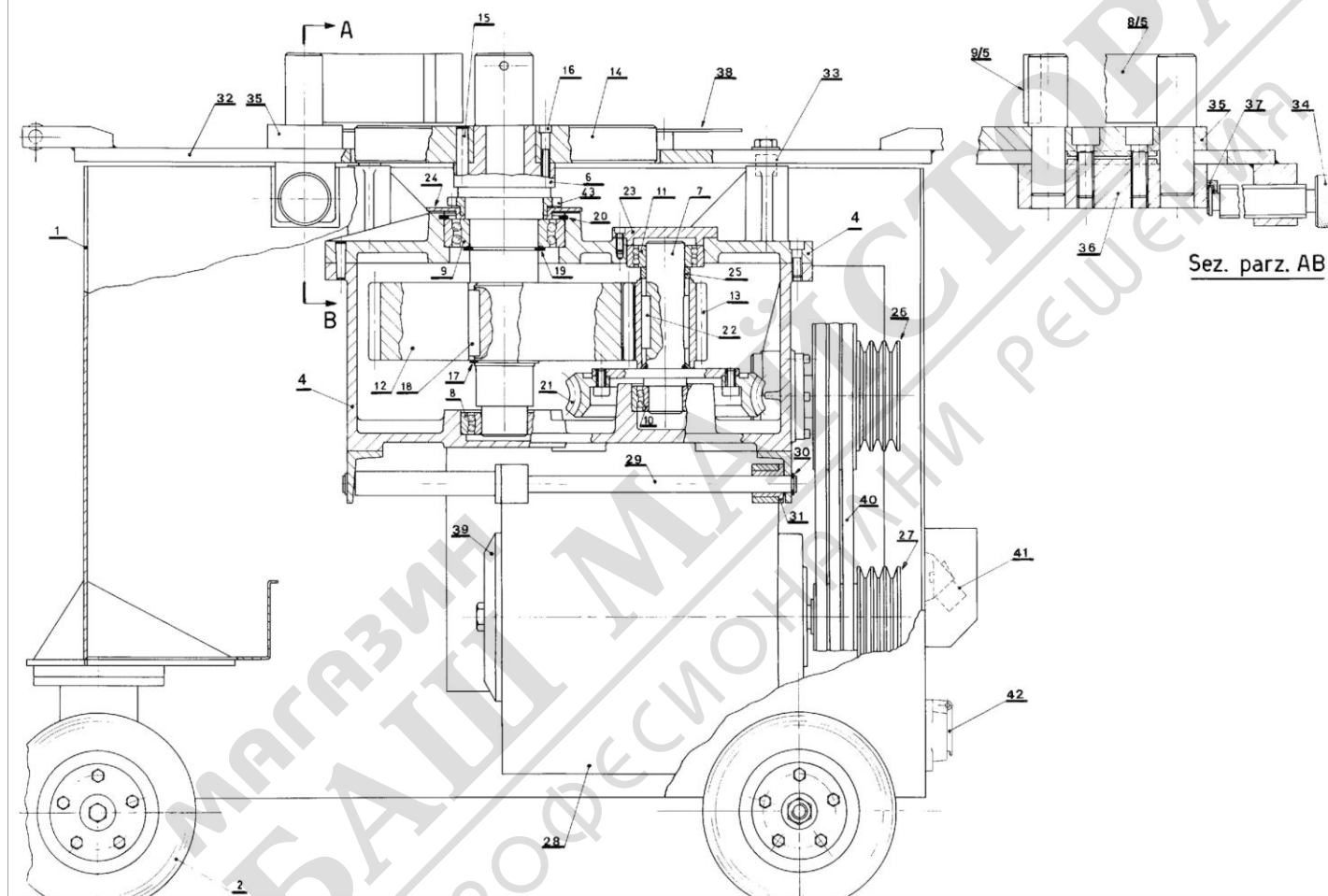

	Tav.01/A	Tav.01/A	Piano di lavoro	Working table
	PS50	PS55	I	GB
Rif	Codice	Codice		
1	PS50.01A.001	PS55.01A.001	Braccio piegatura	Bending arm
2	PS50.01A.002	PS55.01A.002	Protezione centrale	Central protection
3	PS50.01A.003	PS55.01A.003	Protezione laterale	Side protection
4	PS50.01A.004	PS55.01A.004	Piastra superiore di protezione	Up protection plate
5	PS50.01A.005	PS55.01A.005	Piastra inferiore di protezione	Down protection plate
6	PS50.01A.006	PS55.01A.006	Vite M6 x 25 UNI 5931/67	Screw M6 x 25 UNI 5931/67
7	PS50.01A.007	PS55.01A.007	Vite M6 x 30 UNI 5931/67	Screw M6 x 30 UNI 5931/67

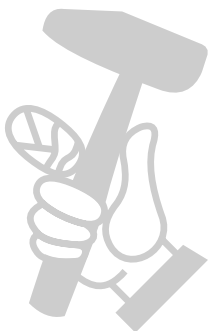
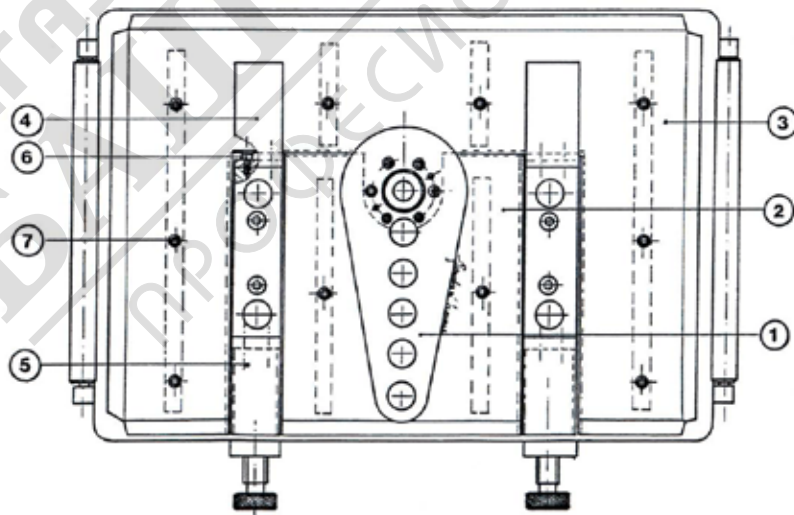

	Tav.02	Tav.02	Tav.02	Tav.02	Gruppo vite senza fine	Screw group
	PS40	PS45	PS50	PS55	I	GB
Rif	Codice	Codice	Codice	Codice		
1	PS40.02.001	PS45.02.001	PS50.02.001	PS55.02.001	Vite senza fine	Screw without end
2	PS40.02.002	PS45.02.002	PS50.02.002	PS55.02.002	Dado	Bolt
4	PS40.02.003	PS45.02.003	PS50.02.003	PS55.02.003	Distanziale	Spacer
3	PS40.02.004	PS45.02.004	PS50.02.004	PS55.02.004	Guarnizione	Gasket
5	PS40.02.005	PS45.02.005	PS50.02.005	PS55.02.005	Guarnizione	Gasket
6	PS40.02.006	PS45.02.006	PS50.02.006	PS55.02.006	Guarnizione	Gasket
7	PS40.02.007	PS45.02.007	PS50.02.007	PS55.02.007	Cuscinetto	Pad
8	PS40.02.008	PS45.02.008	PS50.02.008	PS55.02.008	Boccola	Buckle
9	PS40.02.009	PS45.02.009	PS50.02.009	PS55.02.009	Ghiera	Ferrule
10	PS40.02.010	PS45.02.010	PS50.02.010	PS55.02.010	Cuscinetto	Pad
11	PS40.02.011	PS45.02.011	PS50.02.011	PS55.02.011	Distanziale	Spacer
12	PS40.02.012	PS45.02.012	PS50.02.012	PS55.02.012	Anello filettato	Ring
13	PS40.02.013	PS45.02.013	PS50.02.013	PS55.02.013	Supporto	Support
14	PS40.02.014	PS45.02.014	PS50.02.014	PS55.02.014	Cuscinetto	Pad
15	PS40.02.015	PS45.02.015	PS50.02.015	PS55.02.015	Anello seeger	Seeger ring
16	PS40.02.016	PS45.02.016	PS50.02.016	PS55.02.016	Chiavetta	Key

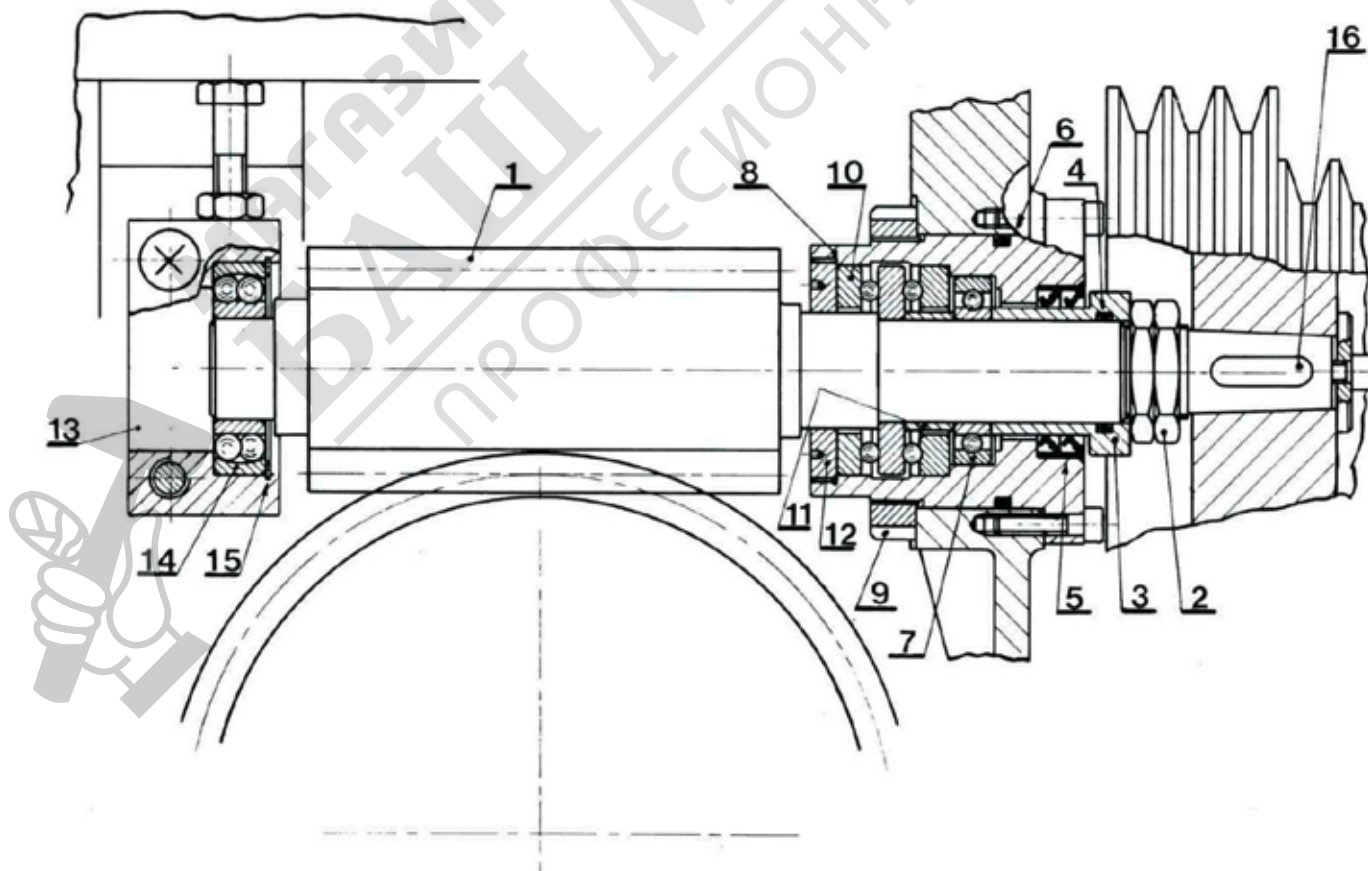
Tav.02 Gruppo vite senza fine

	Tav.03	Tav.03	Tav.03	Tav.03	Dispositivo regolazione angolo di piegatura	Banding angle Regulation
	PS40	PS45	PS50	PS55	I	GB
Rif	Codice	Codice	Codice	Codice		
1	PS40.03.001	PS45.03.001	PS50.03.001	PS55.03.001	Ingranaggio conduttore	Conduction Gear
2	PS40.03.002	PS45.03.002	PS50.03.002	PS55.03.002	Ingranaggio condotto	Conducted Gear
3	PS40.03.003	PS45.03.003	PS50.03.003	PS55.03.003	Perno flangiato	Pivot
4	PS40.03.004	PS45.03.004	PS50.03.004	PS55.03.004	Bronzina	Bearing
5	PS40.03.005	PS45.03.005	PS50.03.005	PS55.03.005	Seeger E 20	E20 Seeger
6	PS40.03.006	PS45.03.006	PS50.03.006	PS55.03.006	Camma	Camshaft
7	PS40.03.007	PS45.03.007	PS50.03.007	PS55.03.007	Bilanciere	Balance Wheel
8	PS40.03.008	PS45.03.008	PS50.03.008	PS55.03.008	Bronzina bilanciere	Balance wheel bearing
9	PS40.03.009	PS45.03.009	PS50.03.009	PS55.03.009	Supporto bilanciere	Balance Wheel support
10	PS40.03.010	PS45.03.010	PS50.03.010	PS55.03.010	Seeger E 15	E15 Seeger
11	PS40.03.011	PS45.03.011	PS50.03.011	PS55.03.011	Molla	Spring
12	PS40.03.012	PS45.03.012	PS50.03.012	PS55.03.012	Perno	Pivot
13	PS40.03.013	PS45.03.013	PS50.03.013	PS55.03.013	Cuscinetto 608 E	608 E Pad
14	PS40.03.014	PS45.03.014	PS50.03.014	PS55.03.014	Supporto	Support
15	PS40.03.015	PS45.03.015	PS50.03.015	PS55.03.015	Spina elastica Ø 4,5x25	Elastic plug Ø 4,5x25
16	PS40.03.016	PS45.03.016	PS50.03.016	PS55.03.016	Cursore	Cursor
17	PS40.03.017	PS45.03.017	PS50.03.017	PS55.03.017	Bronzina	Bearing
18	PS40.03.018	PS45.03.018	PS50.03.018	PS55.03.018	Sfere cursore	Cursor spheres
19	PS40.03.019	PS45.03.019	PS50.03.019	PS55.03.019	Molla	Spring
20	PS40.03.020	PS45.03.020	PS50.03.020	PS55.03.020	Perno	Pivot
21	PS40.03.021	PS45.03.021	PS50.03.021	PS55.03.021	Vite TCCE M4x15	TCCE M4x15 Screw
22	PS40.03.022	PS45.03.022	PS50.03.022	PS55.03.022	Supporto	Support
23	PS40.03.023	PS45.03.023	PS50.03.023	PS55.03.023	Interruttore di finecorsa	Switch
24	PS40.03.024	PS45.03.024	PS50.03.024	PS55.03.024	Supporto finecorsa	Support
25	PS40.03.025	PS45.03.025	PS50.03.025	PS55.03.025	Battuta finecorsa	Beating
26	PS40.03.026	PS45.03.026	PS50.03.026	PS55.03.026	Leva regolazione	Regulation bar
27	PS40.03.027	PS45.03.027	PS50.03.027	PS55.03.027	Seeger E 10	E10 Seeger
28	PS40.03.028	PS45.03.028	PS50.03.028	PS55.03.028	Sfera Ø 30	Sphere Ø 30
29	PS40.03.029	PS45.03.029	PS50.03.029	PS55.03.029	Boccola	Buckle
30	PS40.03.030	PS45.03.030	PS50.03.030	PS55.03.030	Supporto settore	Support
31	PS40.03.031	PS45.03.031	PS50.03.031	PS55.03.031	Settore graduato	Graduated sector
32	PS40.03.032	PS45.03.032	PS50.03.032	PS55.03.032	Piastrina	Plate
33	PS40.03.033	PS45.03.033	PS50.03.033	PS55.03.033	Battuta scorrevole	Sliding Beating
34	PS40.03.034	PS45.03.034	PS50.03.034	PS55.03.034	Porta ingrassatore	Lubrificator rack
35	PS40.03.035	PS45.03.035	PS50.03.035	PS55.03.035	Tubo lubrificazione cursore	Cursor lubrication pipe
36	PS40.03.036	PS45.03.036	PS50.03.036	PS55.03.036	Ingrassatori	Lubrificators

TAV. 3 DISPOSITIVO REGOLAZIONE ANGOLO DI PIEGATURA
BENDING ANGLE CONTROL DEVICE

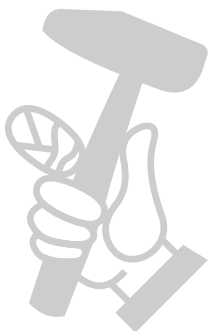
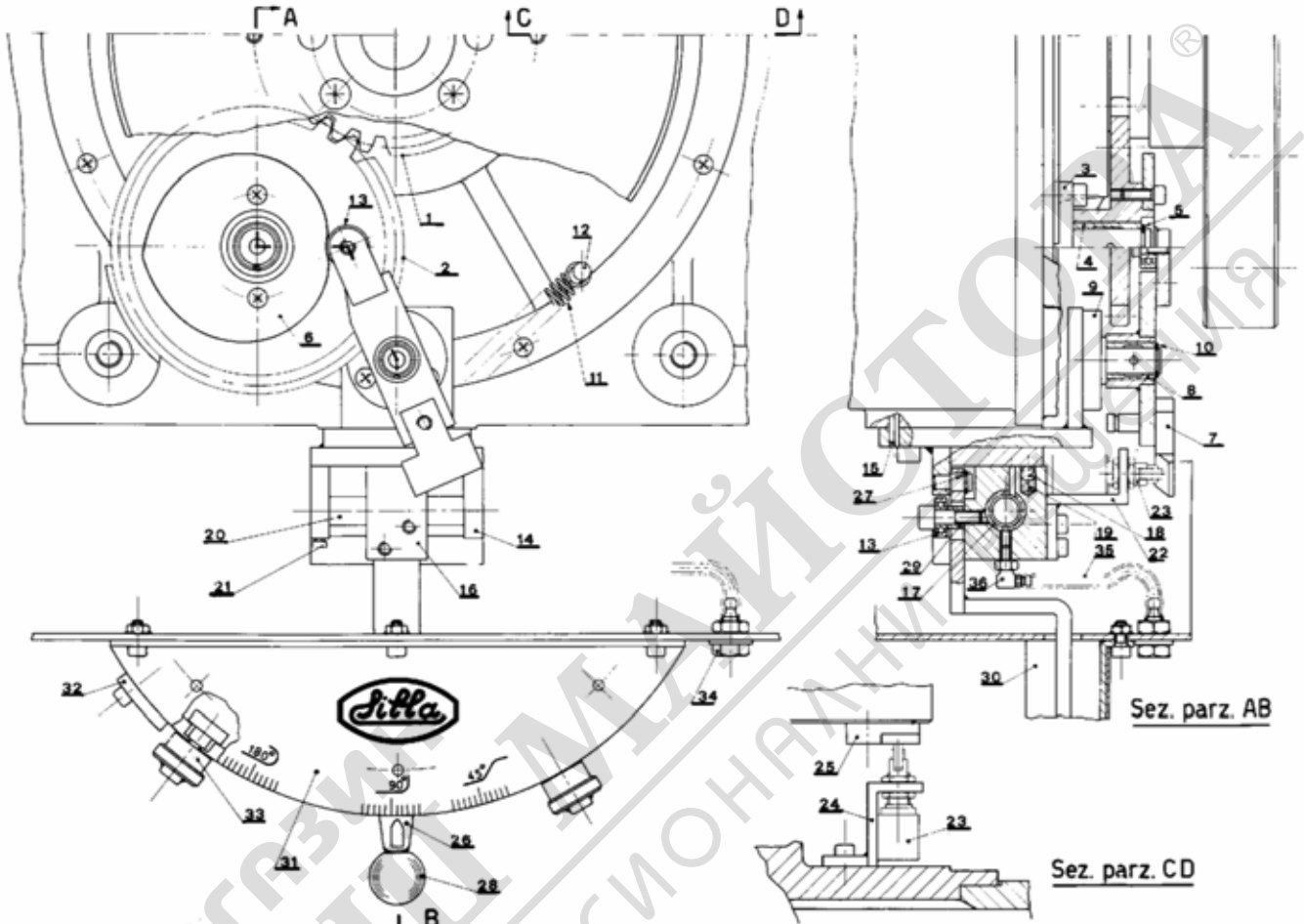

	Tav.04	Tav.04	Tav.04	Tav.04	Serie completa di perni e boccole	Complete range of Pivots and buckles
	PS40	PS45	PS50	PS55	I	GB
Rif	Codice	Codice	Codice	Codice		
1	PS40.04.001	PS45.04.001	PS50.04.001	PS55.04.001	Perno central (Ø32)	Centre Pivot (Ø32)
2	PS40.04.002	PS45.04.002	PS50.04.002	PS55.04.002	Perno central (Ø48)	Centre Pivot (Ø48)
3	PS40.04.003	PS45.04.003	PS50.04.003	PS55.04.003	Perno central (Ø55)	Centre Pivot (Ø55)
4	PS40.04.004	PS45.04.004	PS50.04.004	PS55.04.004	Perno central (Ø70)	Centre Pivot (Ø70)
6	PS40.04.006	PS45.04.006	PS50.04.006	PS55.04.006	Perno laterale (Ø48)	Centre Pivot (Ø48)
7	PS40.04.007	PS45.04.007	PS50.04.007	PS55.04.007	Perno laterale (Ø55)	Lateral Pivot (Ø55)
8	PS40.04.008	PS45.04.008	PS50.04.008	PS55.04.008	Perno laterale (Ø65)	Lateral Pivot (Ø65)
10	PS40.04.010	PS45.04.010	PS50.04.010	PS55.04.010	Boccole (Ø85)	Buckles (Ø85)
11	PS40.04.011	PS45.04.011	PS50.04.011	PS55.04.011	Boccole (Ø95)	Buckles (Ø95)
12	PS40.04.012	PS45.04.012	PS50.04.012	PS55.04.012	Boccole (Ø105)	Buckles (Ø105)
13	PS40.04.013	PS45.04.013	PS50.04.013	PS55.04.013	Boccole (Ø130+ Ø200/50+ Ø250/50)	Buckles (Ø130+ Ø200/50+ Ø250/50)

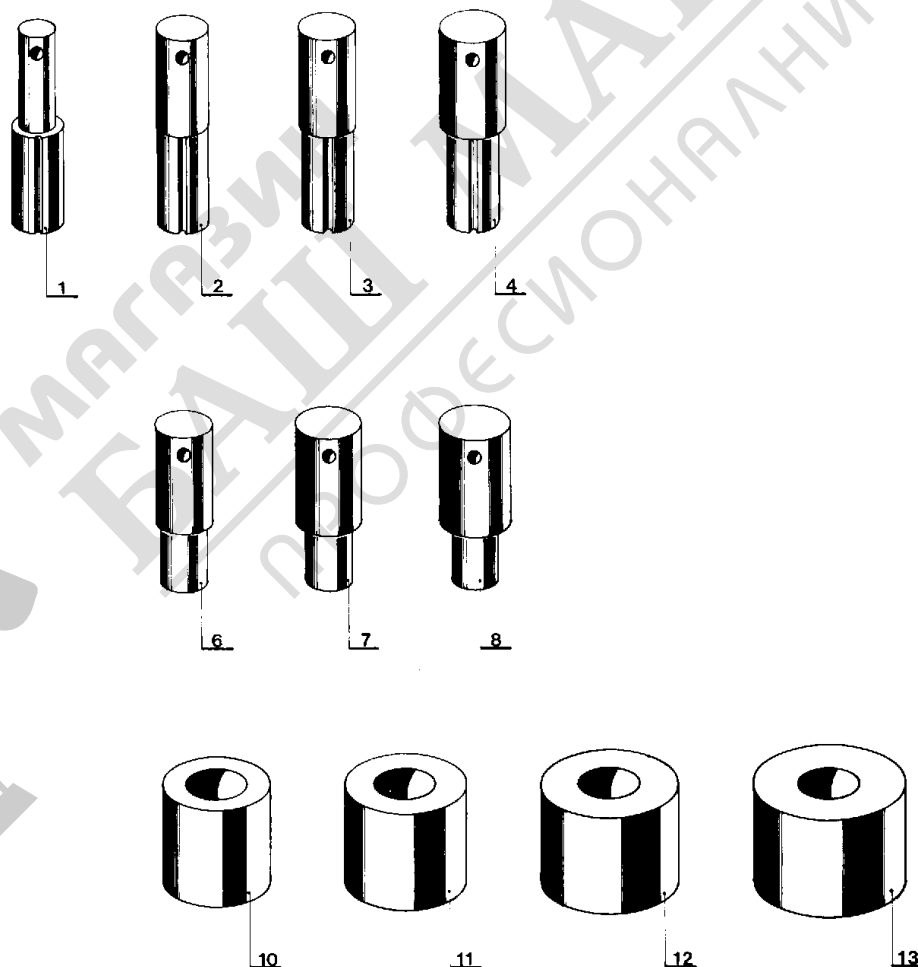
Tav.04 Serie completa di perni e boccole

	Tav.05	Tav.05	Tav.05	Accessori per staffatura	Accessories
	PS40	PS45	PS50	I	GB
Rif	Codice	Codice	Codice		
1	PS40.05.001	PS45.05.001	PS50.05.001	Asta appoggio	Brace
2	PS40.05.002	PS45.05.002	PS50.05.002	Piastra di fissaggio	Fixing plate
3	PS40.05.003	PS45.05.003	PS50.05.003	Cerniera	Hasp
4	PS40.05.004	PS45.05.004	PS50.05.004	Spina elastica	Elastic plug
5	PS40.05.005	PS45.05.005	PS50.05.005	Battuta	Beating
6	PS40.05.006	PS45.05.006	PS50.05.006	Vite	Screw
7	PS40.05.007	PS45.05.007	PS50.05.007	Rondella	Washer
8	PS40.05.008	PS45.05.008	PS50.05.008	Contrasto appoggio	Support contrast
9	PS40.05.009	PS45.05.009	PS50.05.009	Appoggio barre	Bars support

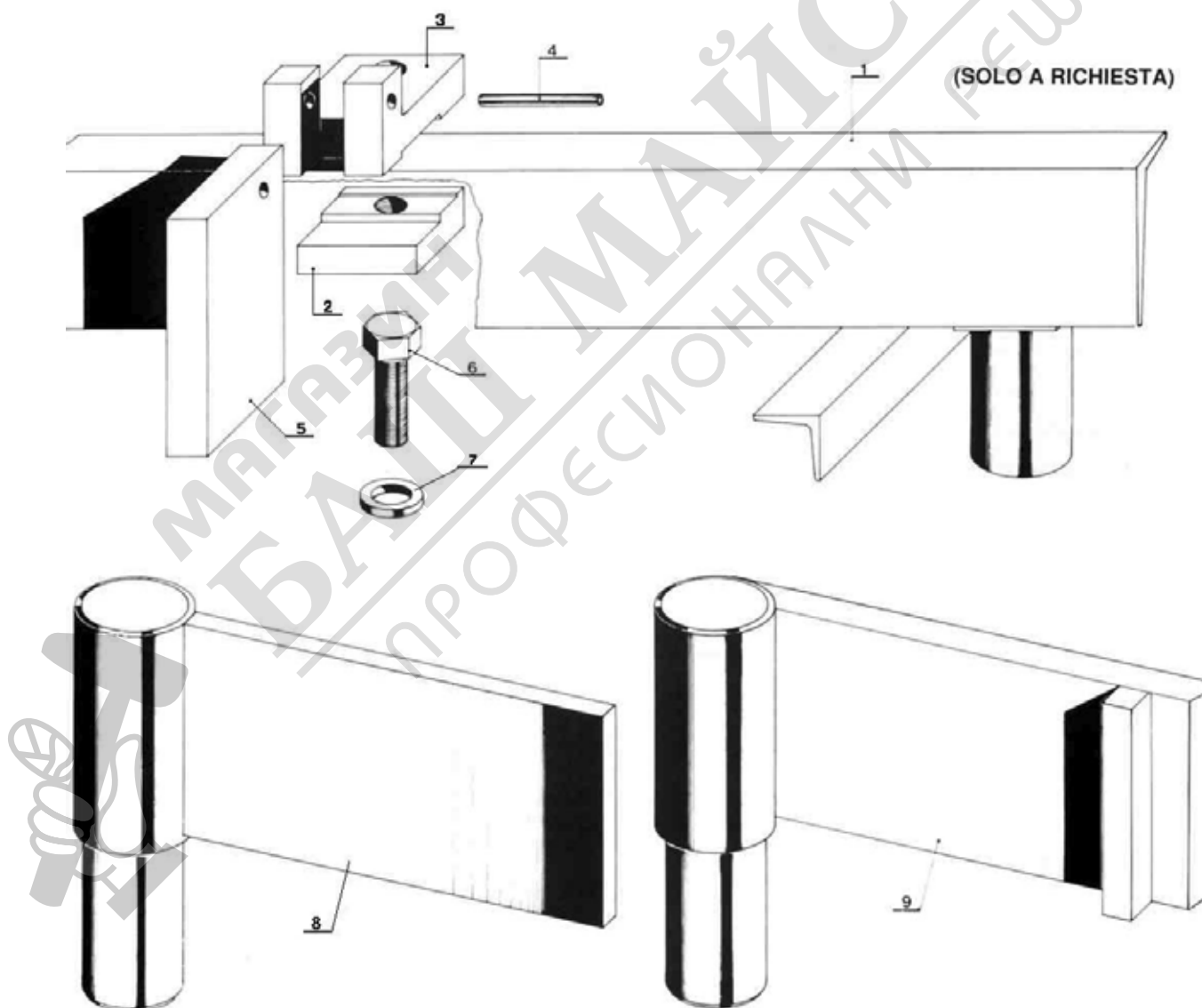

	Tav.06	Tav.06	Tav.06	Tav.06	Cassetta comandi elettrici	Electrical drive box
	PS40	PS45	PS50	PS55	I	GB
Rif	Codice	Codice	Codice	Codice		
1	PS40.06.001	PS45.06.001	PS50.06.001	PS55.06.001	Cassetta elettrica completa	Complete box
2	PS40.06.002	PS45.06.002	PS50.06.002	PS55.06.002	Pannello isolante	Insulating panel
3	PS40.06.003	PS45.06.003	PS50.06.003	PS55.06.003	Teleruttori	Teleruptors
4	PS40.06.004	PS45.06.004	PS50.06.004	PS55.06.004	Morsettiera	Clamps box
5	PS40.06.005	PS45.06.005	PS50.06.005	PS55.06.005	Trasformatore 50 VAR	Transformer
6	PS40.06.006	PS45.06.006	PS50.06.006	PS55.06.006	Scheda elettronica	Electronic CARD
7	PS40.06.007	PS45.06.007	PS50.06.007	PS55.06.007	Salvamotore	Engine saver
8	PS40.06.011	PS45.06.011	PS50.06.011	PS55.06.011	Valvola	Valve
12	PS40.06.012	PS45.06.012	PS50.06.012	PS55.06.012	Pressa cavo	Cable press
13	PS40.06.013	PS45.06.013	PS50.06.013	PS55.06.013	Pulsante di ritorno (verde)	Return switch (green)
14	PS40.06.014	PS45.06.014	PS50.06.014	PS55.06.014	Pulsante di arresto (rosso)	Stop switch (read)
15	PS40.06.015	PS45.06.015	PS50.06.015	PS55.06.015	Pulsante di piega (nero)	Bending switch (black)
16	PS40.06.016	PS45.06.016	PS50.06.016	PS55.06.016	Spie luminose	Lights
17	PS40.06.017	PS45.06.017	PS50.06.017	PS55.06.017	Commutatore di linea	Line changer

