



Manual de utilizare | User's Guide | Manuale dell'utente



INVERTOR TĂIERE CU PLASMĂ (CONTROL IGBT - TRANZISTOR BIPOLAR CU PORȚI IZOLATE, SURSĂ DE ALIMENTARE DE CURENT CONTINUU), pg. 6



DC INVERTER PLASMA CUTTER (POWER IGBT CONTROLIED , DC WELDING POWER SOURCE), pg. 23



TAGLIATRICE A PLASMA TIPO INVERTER (CONTROLLO IGBT - TRANSISTOR BIPOLARE A GATE ISOLATO, TRASFORMATORE SALDATURA IN CORRENTE CONTINUA), pg. 40

CUT-40 / CUT-60 / CUT-80 / CUT-100 / CUT-120



Italia Star Com Due S.R.L.

 Autostrada Bucuresti-Pitesti, km. 13/2, Loc. Chiajna, IF

 004/021.433.03.27  info@italiastar.ro

 www.italiastar.ro



Safety tips !



It may cause injury to you and others during the welding,
please take good protection before welding.

For the details, please read the operator's guide.

Electric-shock: it would be fatal !

- Set the ground cable to the standard.
- No touching electric parts with the naked skin, wet hands or wet groves.
- Make sure that you and working place are under the insulated circumstances.
- Make sure that your working is in safety.

Smoke—may be harmful to your health.

- Keep your head away from the smoke.
- When welding, please keep the fresh air and avoid breathing in the smoke.

Arc-emission—may be harmful to your eyes and skin

- Wear suitable welding mask and clothes to protect your eyes and skin.
- Use suitable screen or curtain to keep the look-ups from the emission .
- The welding splash may cause fire, please ensure that there is no flammable things nearby the working place.

Noises—too much noise may be harmful to your hearing.

- Please wear something to protect your ears from the noises.
- Warn the look-ups of the hidden harm the noise may cause.

Break-down: ask the professional for help

- If you have any problems in setting up or operating, please first consult this manual.
- If you still can not understand after reading this manual, please contact your supplier or manufacturer to get professional help.



Warning!

Use electric leakage protection when using this machine!!!



About Machine

Our plasma power supply adopts advanced inverter technology design, which is suitable for plasma cutting system using compressed air cutting.

The emergence of inverter welding and cutting equipment benefits from the theory of inverter power supply and the emergence of devices:

- (1) Cut40 / 60 / 80 inverter cutting power supply uses high-power single tube IGBT to convert 50 / 60Hz power frequency to high frequency (such as 30kHz). Then, reduce the voltage and adjust the current. At the same time, using PWM technology, we can produce a powerful power supply for cutting.
- (2) The cut 100 / 120 inverter first rectifies the working frequency of 50 / 60Hz to DC, then inverts the high frequency (frequency up to 20kHz) by using the high power switching device IGBT module, then reduces the voltage and rectifies, and then outputs the high power DC source through the PWM technology, which greatly reduces the weight and volume of the main transformer and improves the efficiency by 30%. The arc striking system adopts the principle of high frequency oscillation, which is easy to start the arc, and has the functions of air supply in advance and gas closing in delay. Features: stable, reliable, light, energy-saving, no noise, fast cutting speed, clean cutting mouth, no need to polish.
- (3) Compared with the traditional rectifier technology, inverter technology has the advantages of low energy consumption, light weight, compact structure and better performance.
- (4) Our series of plasma cutting power supply can provide stronger, more concentrated and more stable arc. The air in the arc is almost ionized. The temperature of the arc can reach 10000-15000 °C, reaching a highly ionized state, forming a powerful plasma arc. This means that the plasma arc can be used to cut the metal quickly, the heat affected zone can be reduced as much as possible, the energy can be used effectively, and the cutting surface can be very smooth, which is convenient for subsequent processing.
- (5) Compared with other cutting power supply, our series inverter plasma cutting power supply can provide fast power adjustment and control through advanced electronic circuit, with first-class cutting operation characteristics and high conversion efficiency.
- (6) Our series of inverter plasma cutting power supply can be easily designed into cutting power supply with different characteristics. The output current is continuously adjustable and has excellent operation performance. The overall conversion efficiency of cutting power supply is generally over 85%.
- (7) Our series of plasma cutting power supply has many uses. It is mainly used in the cutting of metal plates, including some cases where other equipment cannot be used for cutting. It can be used for various metal materials with different properties, including stainless steel, alloy steel, carbon steel, copper and other non-ferrous materials. This machine can cut the plate into complex shape according to the need.

Welcome friends from all walks of life to use our products and make valuable suggestions. We are committed to making our products and services perfect.



Warning!

This equipment is mainly used in the industry filed. It may Cause radio interference, preventive action should be taken by the operator.





Parameter Graphic

Model Parameters	CUT-40	CUT-60	CUT-80	CUT-100	CUT-120
Power Voltage (V)	AC230V±15%	AC380V±15%	AC380V±15%	AC380V±15%	AC380V±15%
Rectifying Way	IGBT	IGBT	IGBT	IGBT	IGBT [®]
No load Voltage (V)	270	270	280	300	310
Output Current Rang (A)	10-40	10-60	20-75	20-100	20-120
Rated Output Voltage (V)	96	104	110	120	128
Duty cycle (%)	60	60	60	60	60
Efficiency (%)	85	85	85	85	85
Power Factor	0.7	0.75	0.75	0.75	0.75
Insulation Level	H	H	H	H	H
Protection class of the shell	IP21S	IP21S	IP21S	IP21S	IP21S
Advice the pressure of compressor when cutting (Bar)	3-4	4-5	4-5	4-6	4-6
Cutting Thickness (mm)	1-5	1-10	1-20	1-25	1-40
Weight (kg)	7	11.3	21	29.2	31.5
Dimension (mm)	450*270*345	505*270*410	585*375*500	624*415*530	624*415*530

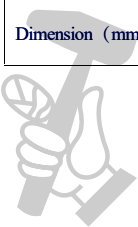



Installation Statements

1. Our series of plasma cutting power supply is equipped with power supply voltage compensation device. When the power supply voltage changes within 15% of the rated voltage, it can still continue to work. When using a long cable, in order to reduce the voltage drop, it is recommended to select a cable with a larger cross-section; if the connecting cable is too long, it may have a greater impact on the arc starting performance of the cutter and other performance of the system, such as the high-frequency arc starting performance is weakened or the system can not work normally. So we recommend that you use the recommended configuration length.
2. Make sure that the cutting power vent is not covered and blocked to avoid cooling system failure. The enclosure shall be reliably grounded with a conductor with a conductive cross-sectional area of not less than 6mm² by connecting the wire from the back of the welding machine to the grounding device, or by confirming that the grounding terminal of the power socket has been reliably and separately grounded. To ensure safety, two methods can also be used at the same time.
3. Connect the gas inlet and compressed air source at the back of the cutting machine with the pressure resistant air pipe, and fasten the interface with the throat hoop or other methods to avoid air leakage. And ensure that the air source can provide appropriate pressure, sufficient flow, and is dry. If your existing gas source cannot meet the above requirements, you should consider using a separate air compressor and gas pressure reducing filter with sufficient power to ensure the normal operation of the machine.
4. Install the gas electric integrated connector of the cutting gun on the corresponding interface of the cutting machine panel, and tighten it clockwise with a wrench. Connect the aviation plug on the cutting gun to the corresponding interface of the cutting machine panel, and tighten the interface screw.
5. Insert the quick plug of the loop cable into the quick socket on the panel of the cutter, tighten it clockwise, and clamp the workpiece with the ground wire clamp at the other end.
6. Connect the power line to the distribution box of the corresponding voltage level according to the input voltage level of the welding machine. Do not connect the wrong voltage. At the same time, ensure that the error of the power supply voltage is within the allowable range.

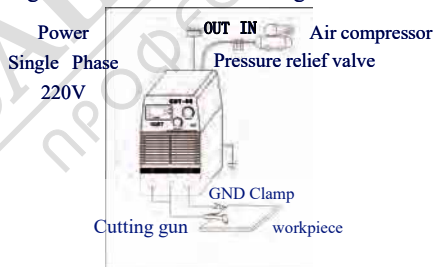

7. Connect the corresponding cable according to the figure, and then proceed to the next step.

Operations

1. Installation and operation of air pressure reducing valve.
2. Screw the copper air nozzle with sealing tape on the in end and out end;
3. Tighten the sealing tape around the meter head at the installation position of the meter head;
4. Fix the connecting frame with nuts at the installation position of pressure reducing valve behind the welding machine as shown in the figure;



12. Screw off the rubber nut and fix the pressure reducing valve on the connecting frame as shown in the figure; Open the air valve switch, raise the pressure regulating knob upward, adjust the air pressure (the scale in the meter head is kgf / cm² value) to the specified air pressure (increase the air pressure by turning to "+" and decrease the air pressure by turning to "-"), and then press the pressure regulating knob;

13. The scale position of the meter head is shown in the figure, and the indicated position in the figure is 4 kgf / cm² air pressure.

14. When there is too much water in the filter cylinder, open the drain valve to drain the water. ☺

Pressure relief valve installation:

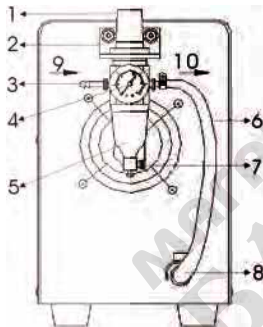
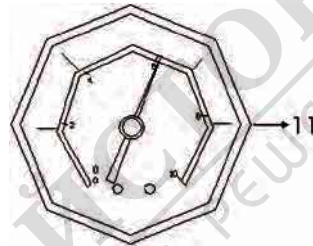
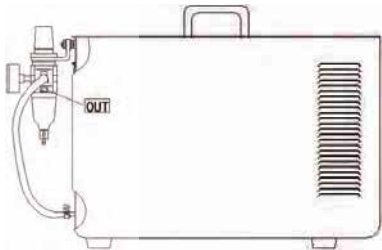

1	Pressure regulating knob
2	Connecting frame
3	Copper air nozzle
4	Barometer
5	Filter gas cylinder
6	Air pipe
7	Drain knob
8	Solenoid Valve
9	Air in
10	Air out
11	Barometer head

Function Explanation

1. Turn the power button on the front panel to the "on" position, the power indicator will be on, and the cooling fan will start to rotate.
2. Open the air valve or switch to control the air and adjust the pressure and air flow to the rated standard (refer to the flow meter).
3. Press the switch on the cutting torch and the solenoid valve will start. You will hear the sound of high-frequency spark discharge in the welding machine. At the same time, there is gas flowing out of the cutting torch nozzle. (for cutting machine with dimension arc, the nozzle of cutting gun is ejected by plasma arc)
4. Set appropriate cutting current according to the thickness of workpiece and process requirements. (panel image needs to be updated)





Panel Chart for CUT40(LGK40)

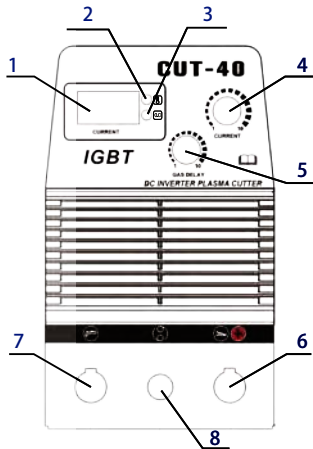

1	Current indicator
2	Overheat indicator light
3	Overcurrent indicator light
4	Current adjusting knob
5	Gas delay knob
6	Positive output
7	Gas-electric integrated output terminal
8	Aviation socket

Panel Chart for CUT60(LGK60)

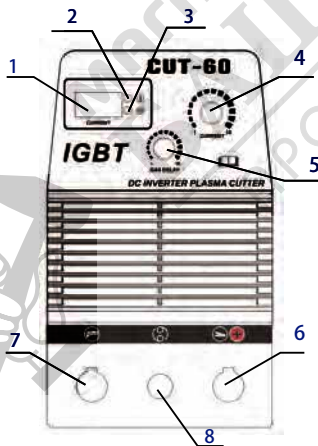

1	Current indicator
2	Overheat indicator light
3	Overcurrent indicator light
4	Current adjusting knob
5	Gas delay knob
6	Positive output
7	Gas-electric integrated output terminal
8	Aviation socket



Panel Chart for CUT100/120(LGK100/120)

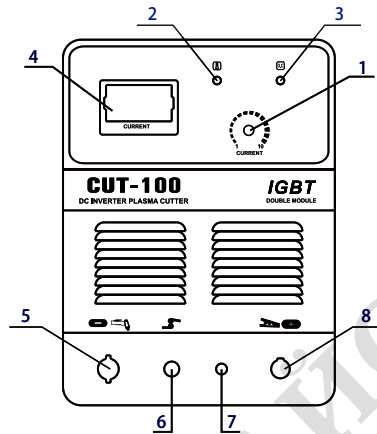

1	Current adjusting knob
2	Overheat indicator light
3	Overcurrent indicator light
4	Current indicator
5	Gas-electric integrated output terminal
6	Aviation socket
7	Dimensional arc output
8	Positive output





Attentions and preventive measures



1.Circumstances

- 1)The welding operation should be on a relative dry environment.The air humidity should not more than 90%.
- 2)The temperature should be during -10 C to 40 C.
- 3)Avoid operating the machine in the rain or sunshine, avoid water entering the machine.
- 4)Do not operate machine in dust environment or aggressive gas environment.
- 5)Avoid ^{shielding gas} welding operation in the environment of strong air flow.

2.Safety

1. Make sure the working area is adequately ventilated .
Welding machine is light and its structure is compact .The electromagnetic fields generated by the high currents .So natural wind is not satisfy in cooling down components .there is axial-flow fan in inter-machine in order to force to cool down it .
2. No over-load !
Limited to welding current strictly according to max allowable current of all kinds of duty cycles . Do not exceed load working in order to prevent from shorting use lifetime of welding machine even burning up machine .
3. No over-voltage !
Power voltage of welding machine is listed on the main technical datasheet .With the normal condition , automatic compensation circuit of voltage may ensure that welding current will not exceed to allowable volume . If power voltage is exceeded to the allowable volume, that may be damaged to components. Please more careful .
- 4 . There is a grounding screw behind machine and marked with ground. Before using, please must be connected reliably by cable with cross- section is more than 6 square millimeter, which release the static and prevent the accident happening.
5. If it is over the duty cycle when working, the machine will stop working and enter the state of protection. On this situation, the overheat temperature control switch would be started and make the machine stop working. The red light is on at the front panel, but still keep the fan running to make the machine cooling. when the red light is off, the temperature will be back to the standard range, then it can work again.

Problems and analysis of cutting

1. The phenomena listed here may be related to the accessories, gas supply, environmental factors and power supply conditions you use. Please try to improve the use conditions to avoid such situations.
2. Rough cutting surface, poor cutting effect.
A. This kind of situation shows that the performance of the cutting machine has not been effectively developed. You can check as follows:
 - a. Confirm that the compressed air source is stable and has enough pressure. Generally, the gas pressure





entering the cutter shall not be less than 0.3MPa (about 3kg / cm²), and its change range shall be within $\pm 0.05\text{Mpa}$.

b. The diameter of electrode and nozzle does not match the cutting current.

The matching relationship between cutting current and nozzle is as follows:

Current Range	10-30A	30-40A	60-80A	80-120A
Injector diameter	$\phi 1.0\text{mm}$	$\phi 1.2\text{mm}$	$\phi 1.3\text{mm}$	$\phi 1.5\text{mm}$

B. It is difficult to start arc and easy to break arc:

1. Confirm that the electrode you are using is of good quality. The discharge capacity of poor quality electrode may not meet the requirements;

2. When the cutting current is too small and the air flow is too large, the arc will break due to the strong cooling effect.

3. The voltage of the power grid is too low or the primary input line is too long, which leads to the excessive voltage drop on the line.

C. Output current not up to rated value:

The deviation of the supply voltage from the rated value will cause the output current to be inconsistent with the set value; the supply voltage is lower than the rated value

The maximum output current of the machine may also be lower than the rated value.

D. The current can't keep stable during the use of cutting machine:

This may be related to the following factors:

1. The grid voltage changes;

2. Serious interference from power grid or other electrical equipment.

E. Electrode or nozzle burned too fast:

1. The current may be too large and the nozzle diameter used is too small;

2. The air pressure is too low to reach the required flow, the cooling effect is weakened, and the nozzle electrode is overheated.

F. The arc can not completely penetrate the steel plate, or the cut is seriously stuck with slag, so it can not be cut smoothly

1. it is possible that the current of this machine cannot reach the required cutting thickness. Please choose a cutting power supply with higher current.

2. The electrode or nozzle has been burned and needs to be replaced.



Attention:

Under normal circumstances, you should start cutting from the edge of the workpiece, so as to ensure the cutting quality. Damage to the cutting gun due to adhesion of spatter.



Daily maintain



Warning:

All maintenance and repair work must be carried out when the power supply is completely cut off. Please make sure that the power plug is unplugged before starting the housing.

- 1)1) Blow dust regularly with dry and clean compressed air. If the cutting machine is used in an environment with heavy smoke and serious air pollution, the cutting machine should be dusted every month.
- 2)2) The pressure of the compressed air should be at a reasonable level to avoid damage to the small components in the cutting machine.
- 3)3) Regularly check the internal circuit connection of the cutting machine to confirm that the line connection is correct and the connector is firm (especially when inserting the connector or component). If rust and looseness are found, sand the rust layer or oxide film with sandpaper and reconnect And tighten it.
- 4)4) Avoid water or vapor entering the cutting machine. If this happens, the inside of the cutting machine should be dried. Then, use a meg-ohmmeter to measure the insulation of the cutting machine (mainly between the external connection nodes). Only if it is confirmed that there is no abnormal situation, the cutting work can be continued.
- 5)If you do not use the cutting machine for a long time, you should put the cutting machine back in the original packing box and store it in a dry environment.

Precautions before maintenance



Warning

Blind experimentation and careless maintenance may lead to the expansion of the fault area, causing difficulties in formal maintenance. The exposed parts of the machine are under dangerous voltage with power on, and any direct or indirect contact may cause click accidents, and serious electric shock will cause death !!!



Note: During the warranty period, if our company does not allow our users to make any faulty inspection of any faults of our welding and cutting power supply, the free repair guarantee provided by the supplier will be invalid.



Failure analysis and maintenance



I. CUT40

Fault records	Solution
The power indicator or digital display is off, the fan does not rotate, and there is no welding output	<ol style="list-style-type: none"> 1. The power switch is broken. 2. Check whether the power grid connected to the input cable has power. 3. Confirm whether the input cable is broken.
The indicator light of the power switch is on, and the fan stops if it does not rotate or rotates a few times.	<ol style="list-style-type: none"> 1. 220V power is unstable (the input line is too thin) or the input line is connected to the power grid, resulting in undervoltage protection The circuit starts, increase the wire diameter of the grid input line or tighten the input line node, this phenomenon is shut down 2- The new boot can return to normal after minutes. 2. The wire between the switch and the power board is loose and tightened again. 3. The main circuit 24V relay on the power board is not attracted or damaged. Check the 24V power supply and the relay. Electrical damage can be replaced with other breakers of the same model.
When the fan rotates, the abnormal indicator light is off, there is no rustling sound of high-frequency discharge, and no gas flows out of the torch nozzle.	<ol style="list-style-type: none"> 1. The multimeter measures the positive and negative voltage of the VH-07 plug-in from the power board to the inverter board should be about DC308V. 2. Check the machine or make poor contact with various patch cords. 3. If there is a problem with the control circuit, find the reason and contact the dealer. 4. The control wire on the cutting gun is broken.
The abnormal indicator light is off, The there is a rustling sound of high-frequency discharge, and it cannot be cut.	<ol style="list-style-type: none"> 1. The cable of the cutting gun is broken. 2. The ground wire is broken or not connected to the workpiece. 3. The connection between the positive output terminal or the gas and electricity integrated output terminal and the machine is loose.
The abnormal indicator light is off, there is no rustling sound of high-frequency discharge, and the torch nozzle has gas flowing out.	<ol style="list-style-type: none"> 1. Poor contact between the primary line of the pilot arc transformer and the power board, and re-tighten. 2. The discharge nozzle is oxidized or the distance is remote. Treat the oxide film on the surface of the discharge nozzle or adjust the distance of the discharge nozzle to 1mm. 3. Individual components of the high-frequency arc starting circuit are damaged, find and replace.



<p>The abnormal indicator light is off</p>	<ol style="list-style-type: none"> 1. It may be over current protection, please turn off the machine, wait for the abnormal indicator light to turn off and then restart to restore normal. 2. It may be overheating protection, and the machine can return to normal without waiting for 2-3 minutes. 3. The inverter circuit may be faulty, please unplug the power supply plug of the main transformer on the inverter board and restart it: If the abnormal indicator light is still on, shut down and unplug the power supply plug of the high-frequency arc starting power supply (the control line from the mid PCB to the Bottom PCB) to restart: <ol style="list-style-type: none"> a. If the abnormal indicator light is still on, some IGBTs on the inverter board are damaged. Find and replace the same type IGBT. <ol style="list-style-type: none"> b. If the abnormal indicator is off, the high voltage package in the high-frequency arc starting circuit on the power supply board is damaged. Replace it. (2) If the abnormal indicator does not light: <ol style="list-style-type: none"> a. The mid-board transformer may be damaged, and the primary inductance and Q value of the main transformer can be measured with a bridge b. It may be that the secondary rectifier tube of the transformer breaks down individually. Find and replace the same type of rectifier tube. 4. The feedback circuit may be broken.
<p>The output current is unstable or not controlled by the potentiometer during cutting.</p>	<ol style="list-style-type: none"> 1. The 1K potentiometer should be replaced if it is damaged. 2. Poor contact at various connections, especially connectors, etc., need to be checked.

II.CUT60/80

Fault	Solution
<p>The fan does not rotate, the digital meter has no display, and no welding output.</p>	<ol style="list-style-type: none"> 1. Confirm that the air switch is intact or closed. 2. Confirm that the power grid connected to the output cable has power. 3. The thermistor on the power board is damaged (this situation is generally caused by the DC24V relay not closing or the poor contact of the contacts). 4. The power board (bottom board) fails, and there is no DC537V voltage output. 5. The auxiliary power supply part of the control board is faulty.
<p>When the fan rotates, the abnormal indicator light is off, no gas flows out of the torch mouth, and there is no high-frequency discharge sound in the machine.</p>	<ol style="list-style-type: none"> 1. Check all kinds of patch cords in the machine for poor contact. 2. Control circuit problems, find the cause or contact the dealer. 3. The control wire on the cutting gun is broken.
<p>The abnormal indicator light is off, there is gas flowing out of the torch tip, and it cannot be cut.</p>	<ol style="list-style-type: none"> 1. The cable of the cutting gun is broken. 2. The ground wire is broken or not connected to the workpiece. 3. The connection between the positive output terminal or the gas and



	electricity integrated output terminal and the machine is loose.
The abnormal indicator light is off, there is gas flowing out of the torch mouth, and there is no high-frequency discharge sound in the machine.	<ol style="list-style-type: none"> 1. Poor contact between the primary line of the arc-starting transformer and the arc-starting plate and re-tighten. 2. The discharge nozzle is oxidized or the distance is remote. Treat the oxide film on the surface of the discharge nozzle or adjust the distance of the discharge nozzle to 1mm about. 3. Individual components of the high-frequency arc starting circuit are damaged, find and replace them.
Abnormal indicator light without output	<ol style="list-style-type: none"> 1. It may be over current protection, please turn off the machine, wait for the abnormal indicator light to turn off and then restart to restore normal. 2. It may be overheating protection, and the machine can return to normal without waiting for 2-3 minutes. 3. The inverter or arc board may be faulty: Please unplug one of the power supply cords on the inverter board (near the fan VH-07 Plug-in) Restart: If the abnormal indicator does not light, the fault is on this inverter movement (1) The indicator light is still on, turn off and unplug the power supply on the arc board (close to the VH-03 plug of the fan)] restart: a. If the abnormal indicator is still on, it means that some IGBTs on the inverter board are damaged. Find and replace the same type IGBT. b. If the abnormal indicator light is off, the fault is in the arc board, the high voltage package is damaged, replace it. (2) Plug in the power supply cable of the faulty inverter, and do not plug in the power cable of the main transformer. a. If the abnormal indicator does not light and the fault is on the middle PCB, the transformer may be damaged, and the bridge can be used to measure Primary inductance and Q value of each main transformer Primary inductance of main transformer and Q value $L = 1.2-1.6\text{Mh} > 35$ b. The middle plate rectifier tube may be damaged individually. Find and replace the same type of rectifier tube. 4. The feedback circuit may be broken.

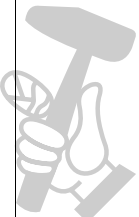



III.CUT100/120

Fault	Solution
No display,the fan does not rotate.	<ol style="list-style-type: none"> 1. Confirm that the air switch is closed. 2. The power supply connected to the input cable has power. 3. Confirm that the power supply has no phase loss.
Header display normal, Fan rotates normally ,The buttons on the cutting gun do not work.	<ol style="list-style-type: none"> 1. Check whether the various patch cords in the machine are poor contact. 2. The control wire on the cutting gun is broken or the micro switch is damaged. 3. The control circuit is damaged (contact the dealer or manufacturer)
Header display normal, Fan rotates normally ,the abnormal indicator is on.	<ol style="list-style-type: none"> 1. Whether the high-voltage package is broken; 2. IGBT damage 3. Quick recovery of damaged rectifier tube 4. Control board failure 5. The feedback circuit is faulty (the abnormal indicator light is on).
The fan rotates normally, , The meter display is normal , Solenoid valve action , No dimension arc output , The abnormal indicator is off.	<ol style="list-style-type: none"> 1. There is a problem in the arc starting part 2. The discharge nozzle is too far away or there is adhesion 3. The high voltage package is damaged 4. Damage to the pilot arc relay 5. Control circuit failure
Air switch does not close.	<ol style="list-style-type: none"> 1. The quality problem of the air switch itself 2. The three-phase rectifier bridge is damaged and needs to be replaced 3. Check if there is a short circuit inside the machine





VI.Schematic Diagram

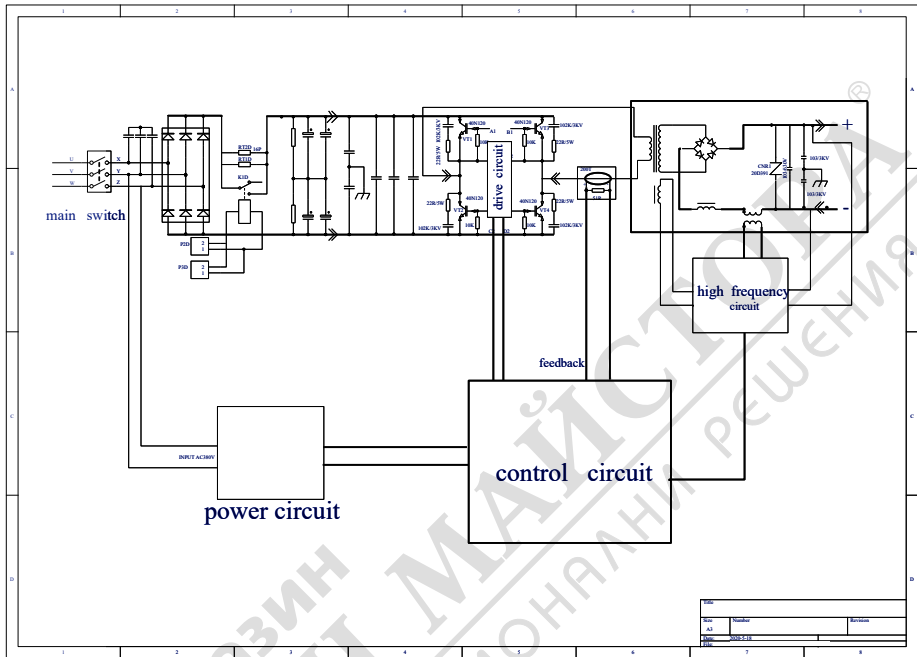

МАГАЗИН
БАШ МАЙСТЕР
ПРОФЕСИОНАЛНИ РЕШЕНИЯ

Machine register, tests and maintenance

Nr.	Date	Fault description	Repaires performed	Guarantee extension	L.S.
1					
2					
3					
4					
5					



Authorized service:

Italia Star Com Due S.R.L.
 Autostrada Bucuresti - Pitesti km. 13.2
 Loc. Chiajna - Ilfov
 Tel: 021.433.03.27
 Fax: 021.433.03.26
 info@italiastar.ro www.italiastar.ro



Warranty Certificate

Series AA No. _____

Product name: _____

Model : _____

Series no.: _____

Accessories: _____

Seller: _____

Signature / stamp: _____

Buyer: _____

Address : _____

Date of purchase: _____

Signature / stamp: _____

DISTRIBUTOR: _____

NAME: _____

ADDRESS: _____

I hereby confirm that I received the product in perfect condition with the utilization manual and I fully agree that this warranty certificate is valid only accompanied with the purchase invoice or receipt. If the product is not accompanied by this certificate or warranty is expired or canceled by the service due to abnormal usage conditions, the repairs will be done and charged after my consent.

Warranty Conditions

..... months warranty period from the date of purchase.

The service under terms of warranty has to be required to the closest Authorised Assistance Centre (you can find the list in our sales network or check it on our website www.italiastar.ro in the Service area) ; the buyer has to apply for warranty always showing documents about the date of purchase of the item itself.

As warranty we mean repair or substitution of those spares that have manufacturing defects.

For all the Italia Star products, the terms of warranty are one year after the date of delivery to the user.

Repairs done during the warranty period do not interrupt the period of the general warranty itself.

The warranty service include repair or substitution of all the defective parts; if the repair is done at the customer's place all the transfer to and from the assistance centre will be charged to the purchaser.

All the reparations under terms of warranty, even if done in one of our authorised assistance centres, have to be approved by Italia Star Service department in order to allow the reparations.

The warranty cannot be accepted in the following cases:

- When the repair or substitution of the parts has been done by a non-authorised Italia Star assistance service;
- When the cause of the problem is due to the use of non original Italia Star spare parts;
- When the user install on the machine non original or not indicated on the manual accessories;
- When the product has been, modified, repaired, disassembled from the buyer or from others;
- When there are modifications in the product done without Italia Star authorisation that can have influence on the correct functioning of the product;
- In case of incorrect start-up, incorrect use of the machine, incorrect use of the instruction given in the operating and maintenance manual, and not execution of the maintenance scheduled procedures;

- In case of natural disasters;
- In case of standard wear and tear;
- In case of damages caused by use of inadequate fuel and lubricant;
- In case of damages to the electrical components caused by an inadequate electrical system, in case of problems given by the electrical alimentation net, or by connections done without following the instruction of the operating and maintenance manual.

The warranty is granted within the following operating hours:

- Diesel / gasoline engines operating at 3000 rpm - 1000 hours
- Diesel engines operating at 1500 rpm - 2000 hours
- * Subject to the maintenance schedule specified in the user manual.
- * Brushes are not covered by warranty, those are consumables.

***THE WARRANTY IS NOT TRANSMISSIBLE**

Authorized Service

Name: _____

Address: _____

Phone: _____

e-mail: _____