

Milwaukee[®]

Nothing but **HEAVY DUTY**.[®]

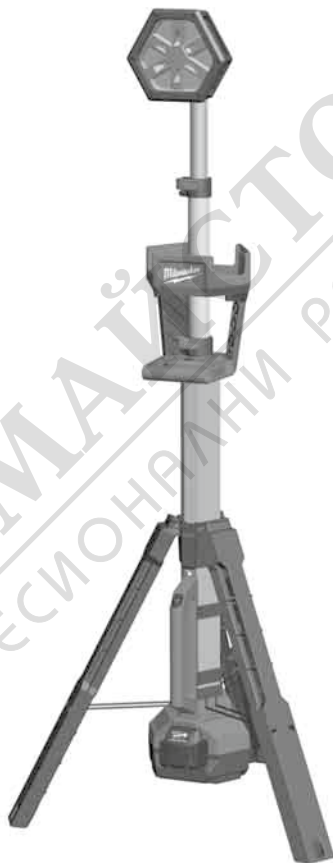

M18 SAL

Original instructions

10



14

Text section with Technical Data, important Safety and Working Hints and description of Symbols

8



6



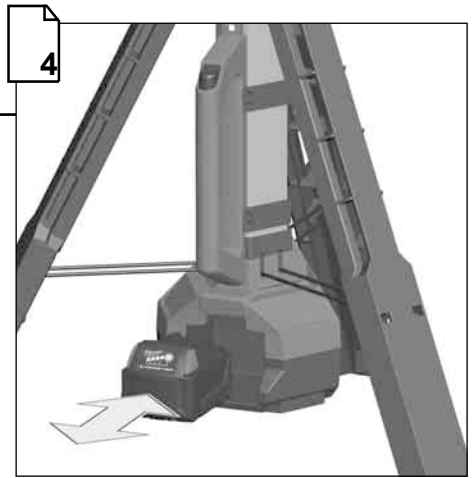
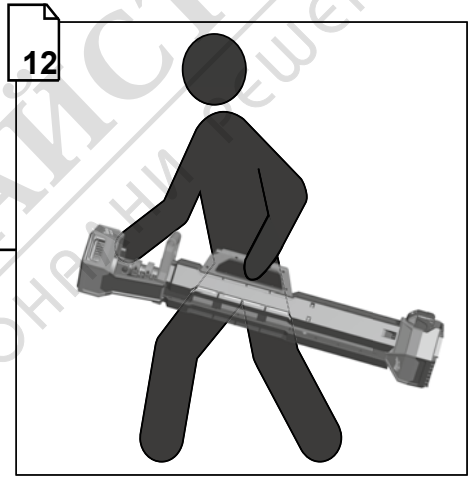
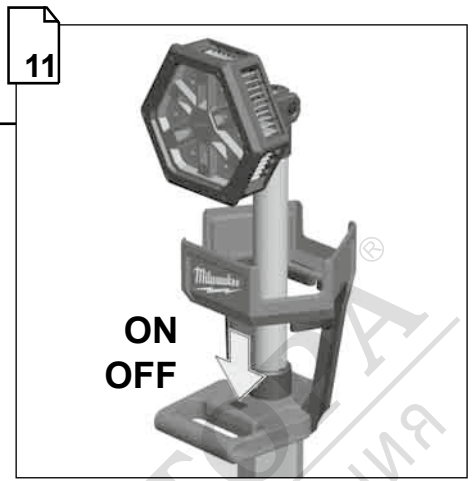

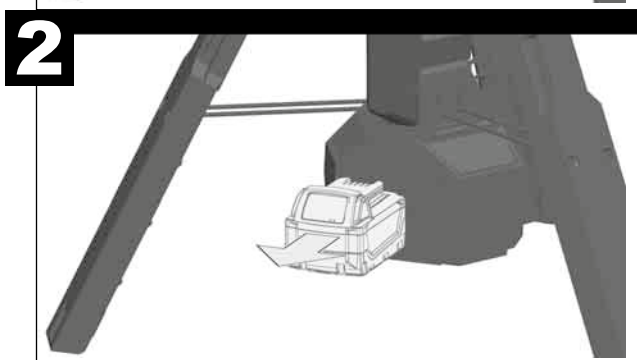
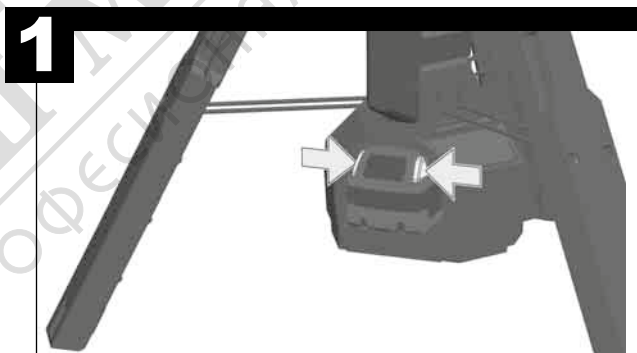
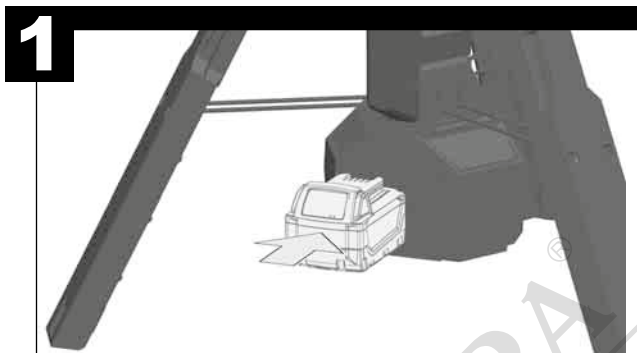

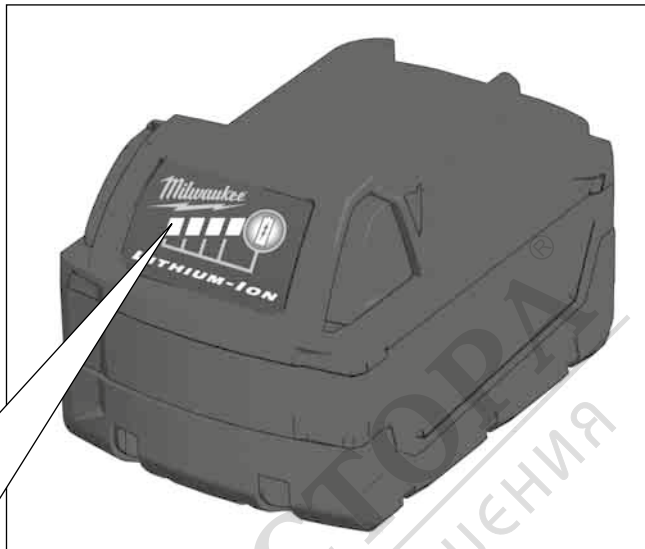

78-100 %



55-77 %



33-54 %



10-32 %

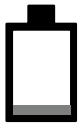

< 10 %

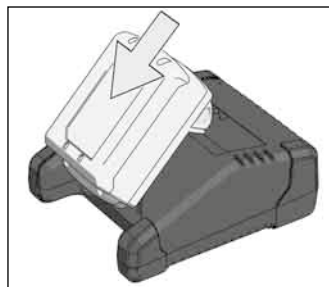
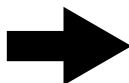

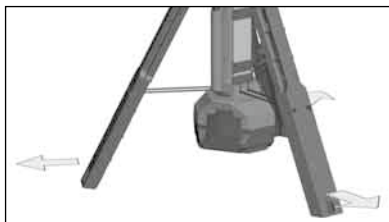

1

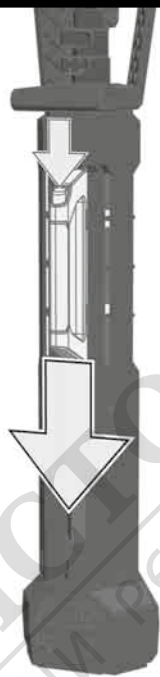

2

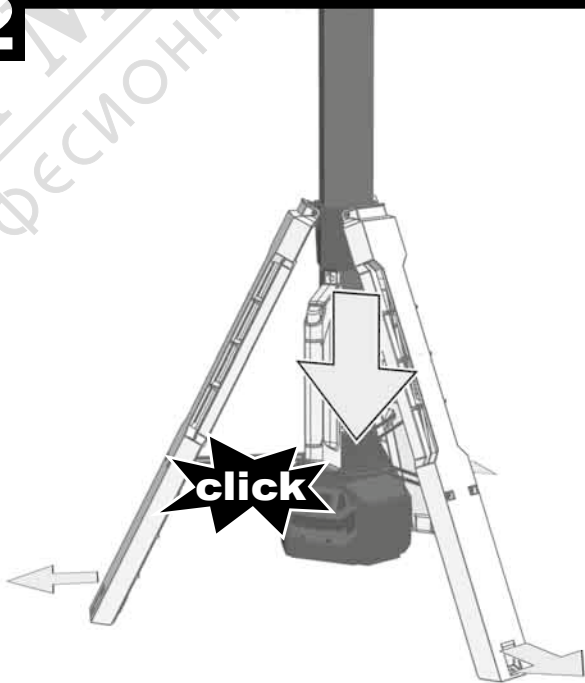

МАГАЗИН МАЙСТОРА®
БАШТА
ПРОФЕСІОНАЛНІ РЕШЕННЯ

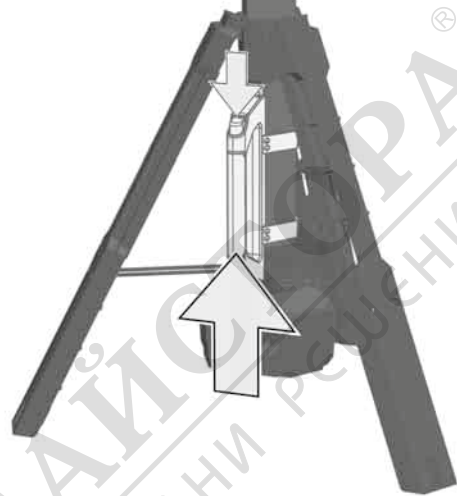
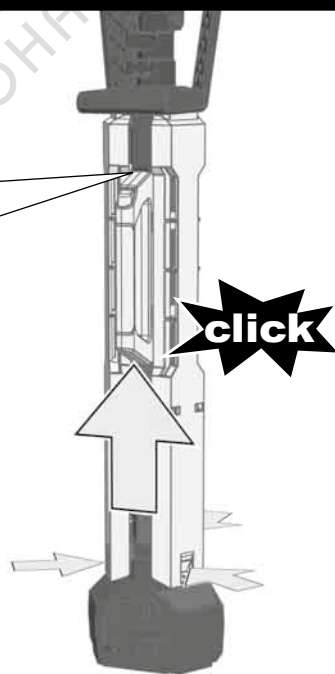
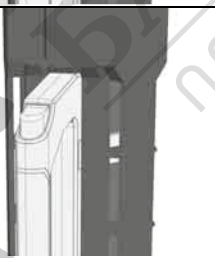
1**2**

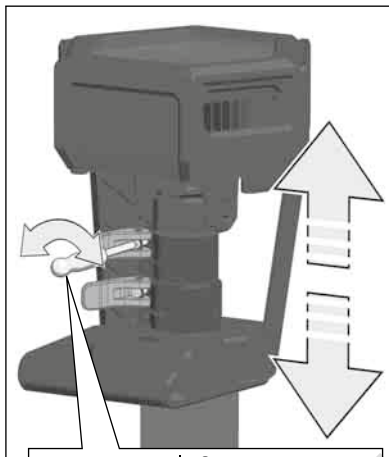
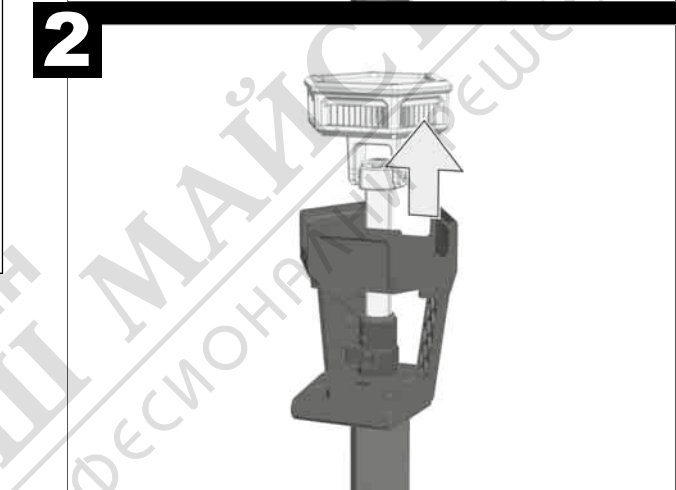
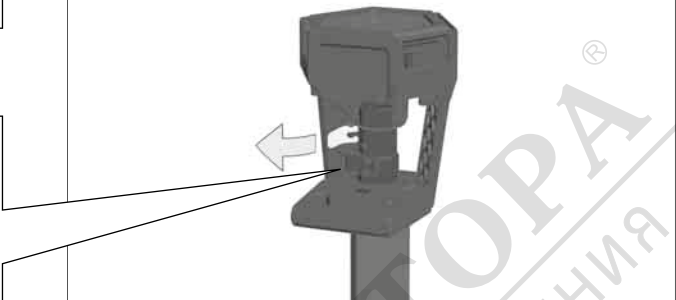
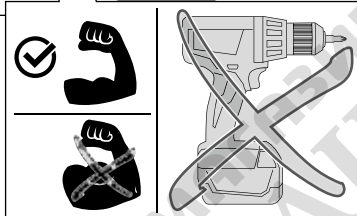
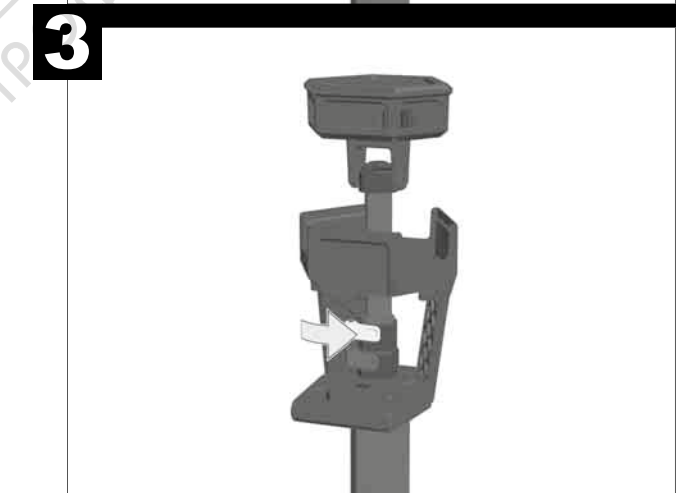
**1****2****3**

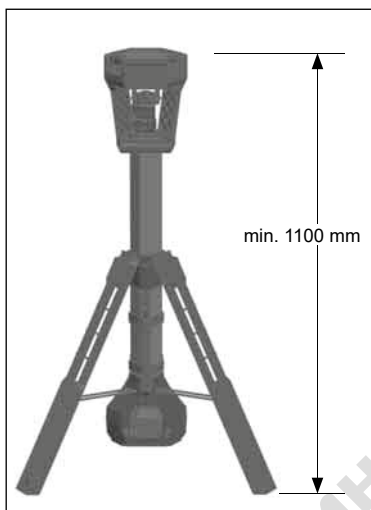

4



5

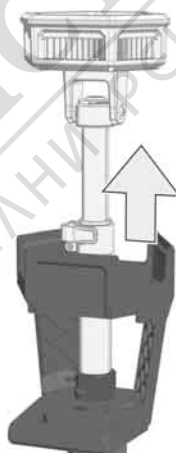

6



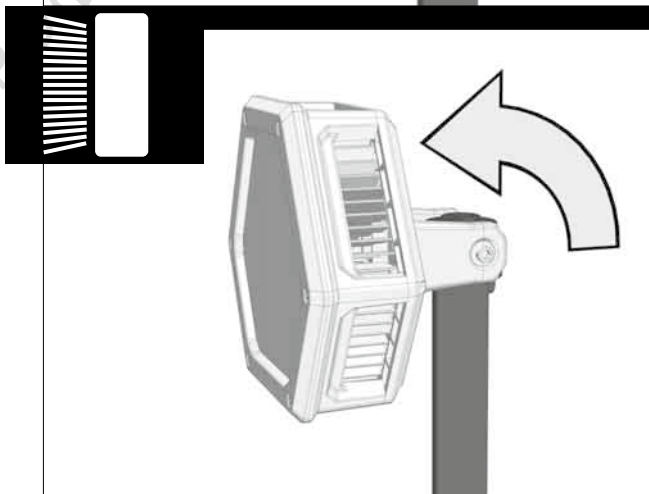
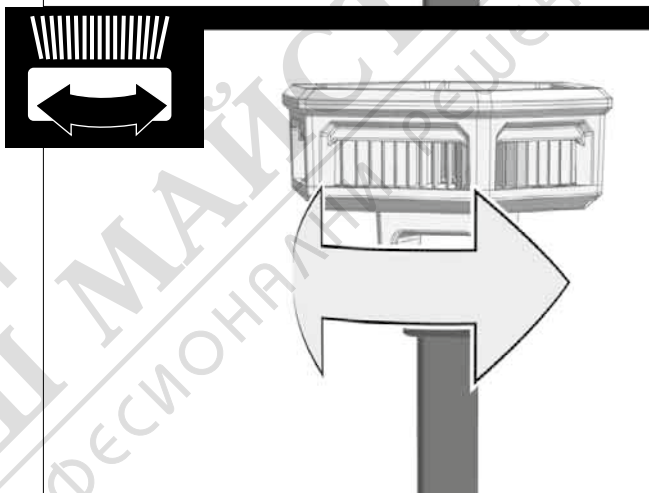
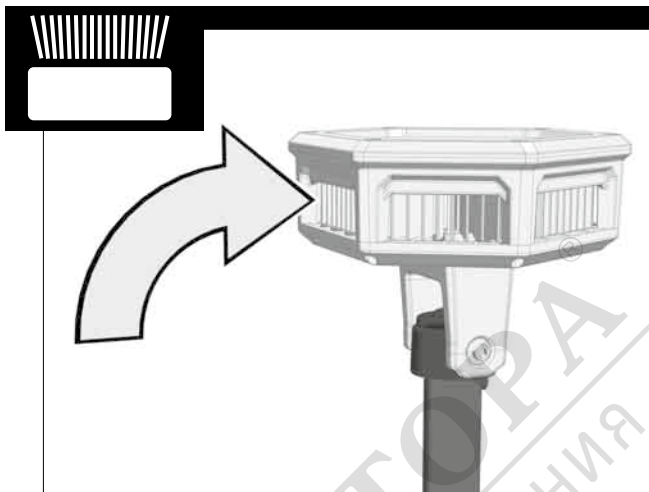
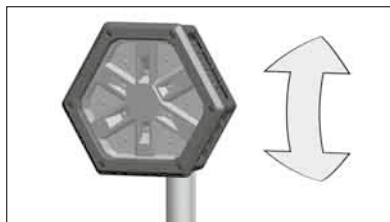

МАГАЗИН МАЙСТОР
БАШ МАЙСТОР
ПРОФЕСИОНАЛЬНА СЛУЖБА

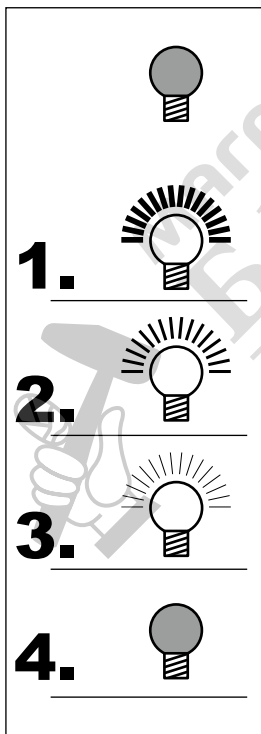
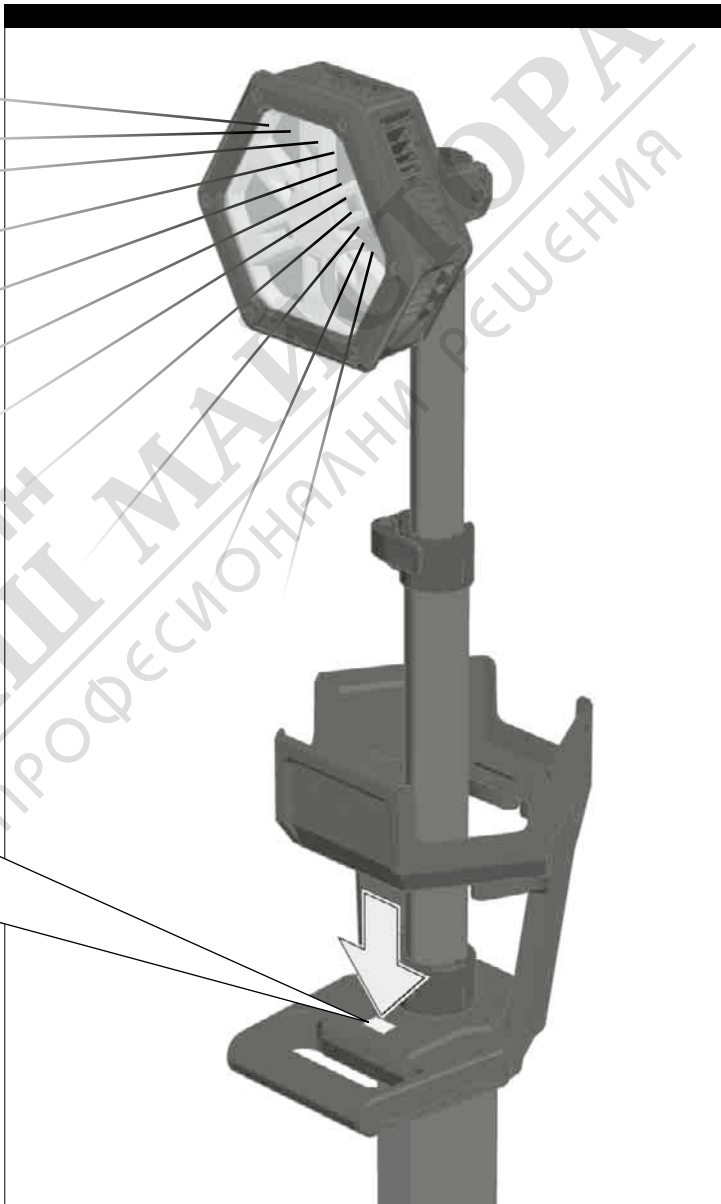

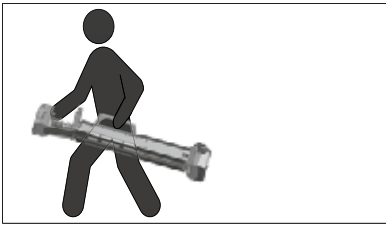

Lightning time with one fully charged battery (5.0 Ah)	
High Level.....	4 h (2000 lm)
Med Level.....	6 h (1300 lm)
Low Level.....	10 h (850 lm)
Battery voltage.....	18 V
Weight according EPTA-Procedure 01/2014 (5.0 Ah).....	7,68 kg
Protection class	
Dust and water resistance.....	IP 54

⚠ WARNING! Read all safety warnings and all instructions. Failure to follow the warnings and instructions may result in electric shock, fire and/or serious injury.
Save all warnings and instructions for future reference.

SAFETY INSTRUCTIONS

Remove the battery pack before starting any work on the appliance.

Do not dispose of used battery packs in the household refuse or by burning them. Milwaukee Distributors offer to retrieve old batteries to protect our environment.

Do not store the battery pack together with metal objects (short circuit risk).

Use only compatible Milwaukee chargers from the same battery platform for charging battery packs. Do not use battery packs from other systems.

Battery acid may leak from damaged batteries under extreme load or extreme temperatures. In case of contact with battery acid wash it off immediately with soap and water. In case of eye contact rinse thoroughly for at least 10 minutes and immediately seek medical attention.

Warning: Do not direct the light beam at persons or animals and do not stare into the light beam yourself (not even from a distance). Staring into the light beam may result in serious injury or vision loss.

Don't use this tool in wet areas .

Warning! To reduce the risk of fire, personal injury, and product damage due to a short circuit, never immerse your tool, battery pack or charger in fluid or allow a fluid to flow inside them. Corrosive or conductive fluids, such as seawater, certain industrial chemicals, and bleach or bleach containing products, etc., can cause a short circuit.

SPECIFIED CONDITIONS OF USE

The area light is intended to be used light independent use away from mains supply.

Do not use this product in any other way as stated for normal use.

BATTERIES

Battery packs which have not been used for some time should be recharged before use.

Temperatures in excess of 50°C (122°F) reduce the performance of the battery pack. Avoid extended exposure to heat or sunshine (risk of overheating).

The contacts of chargers and battery packs must be kept clean.

For an optimum life-time, the battery packs have to be fully charged, after used.

To obtain the longest possible battery life remove the battery pack from the charger once it is fully charged.

For battery pack storage longer than 30 days:
 Store the battery pack where the temperature is below 27°C and away from moisture

Store the battery packs in a 30% - 50% charged condition
 Every six months of storage, charge the pack as normal.

TRANSPORTING LITHIUM BATTERIES

Lithium-ion batteries are subject to the Dangerous Goods Legislation requirements.

Transportation of those batteries has to be done in accordance with local, national and international provisions and regulations.

- The user can transport the batteries by road without further requirements.
- Commercial transport of Lithium-Ion batteries by third parties is subject to Dangerous Goods regulations. Transport preparation and transport are exclusively to be carried out by appropriately trained persons and the process has to be accompanied by corresponding experts.

When transporting batteries:

- Ensure that battery contact terminals are protected and insulated to prevent short circuit.
- Ensure that battery pack is secured against movement within packaging.
- Do not transport batteries that are cracked or leak.

Check with forwarding company for further advice

MAINTENANCE

The light source of this luminaire is not replaceable; when the light source reaches its end of life the whole luminaire shall be replaced.

Use only Milwaukee accessories and spare parts. Should components need to be replaced which have not been described, please contact one of our Milwaukee service agents (see our list of guarantee/service addresses).

If needed, an exploded view of the tool can be ordered. Please state the machine type printed as well as the six-digit No. on the label and order the drawing at your local service agents or directly at: Techtronic Industries GmbH, Max-Eyth-Straße 10, 71364 Winnenden, Germany.

SYMBOLS



CAUTION! WARNING! DANGER!



CAUTION: Possibly hazardous optical radiation emitted from this product. Do not stare at operating lamp. May be harmful to the eye.



Please read the instructions carefully before starting the machine.



Do not dispose electric tools, batteries/ rechargeable batteries together with household waste material.

Electric tools and batteries that have reached the end of their life must be collected separately and returned to an environmentally compatible recycling facility.
 Check with your local authority or retailer for recycling advice and collection point.



Safety class III



European Conformity Mark

British Conformity Mark



Ukraine Conformity Mark



EurAsian Conformity Mark

МАГАЗИН
БАШ МАЙСТОРА®
ПРОФЕСИОНАЛНИ РЕШЕНИЯ



МАГАЗИН
БАШ МАЙСТОРА®
ПРОФЕСИОНАЛНИ РЕШЕНИЯ



Copyright 2020
Techtronic Industries GmbH
Max-Eyth-Str. 10
71364 Winnenden
Germany
+49 (0) 7195-12-0
www.milwaukeeetool.eu

Techtronic Industries (UK) Ltd
Fieldhouse Lane
Marlow Bucks SL7 1HZ
UK



(11.20)

4100 4146 99