

МАГАЗИН МАЙСТОРА®  
БАШ МАЙСТОРА®  
ПРОФЕСИОНАЛНИ РЕШЕНИЯ

**GB**

## **Operator's manual**

Please read the operator's manual carefully and make sure you understand the instructions before using the machine.

**ES**

## **Manual de instrucciones**

Lea detenidamente el manual de instrucciones y asegúrese de entender su contenido antes de utilizar la máquina.

**PT**

## **Instruções para o uso**

Leia as instruções para o uso com toda a atenção e compreenda o seu conteúdo antes de fazer uso da máquina.

**GR**

## **Οδηγίες χρήσεως**

Διαβάστε προσεκτικά τις Οδηγίες χρήσεως και κατανοήστε το περιεχόμενο πριν χρησιμοποιήσετε το μηχάνημα.

**CS 10**

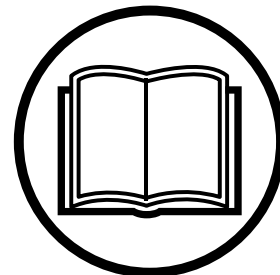

**GB ES PT GR**

# KEY TO SYMBOLS

## Symbols on the machine

**WARNING!** The machine can be a dangerous tool if used incorrectly or carelessly, which can cause serious or fatal injury to the operator or others.

Please read the operator's manual carefully and make sure you understand the instructions before using the machine.

Wear personal protective equipment. See instructions under the "Personal protective equipment" heading.

This product is in accordance with applicable EC directives.

**Environmental marking.** Symbols on the product or its packaging indicate that this product cannot be handled as domestic waste. It must instead be submitted to an appropriate recycling station for the recovery of electrical and electronic equipment.

By ensuring that this product is taken care of correctly, you can help to counteract the potential negative impact on the environment and people that can otherwise result through the incorrect waste management of this product.

For more detailed information about recycling this product, contact your municipality, your domestic waste service or the shop from where you purchased the product.

**Other symbols/decals on the machine refer to special certification requirements for certain markets.**



## Explanation of warning levels

The warnings are graded in three levels.

### WARNING!



**WARNING!** Used if there is a risk of serious injury or death for the operator or damage to the surroundings if the instructions in the manual are not followed.

### CAUTION!



**CAUTION!** Used if there is a risk of injury to the operator or damage to the surroundings if the instructions in the manual are not followed.

### NOTICE!



**NOTICE!** Used if there is a risk of damage to materials or the machine if the instructions in the manual are not followed.

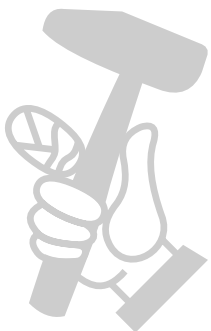

# CONTENTS

## Contents

### KEY TO SYMBOLS

Symbols on the machine .....	2
Explanation of warning levels .....	2

### CONTENTS

Contents .....	3
----------------	---

### PRESENTATION

Dear Customer, .....	4
Design and features .....	4
What is what on the machine? .....	5

### MACHINE'S SAFETY EQUIPMENT

General .....	6
---------------	---

### ASSEMBLING AND ADJUSTMENTS

General .....	7
Use with existing track .....	7
Secure the base plate .....	7
Assembling the saw .....	8
Thread the wire .....	10
Assemble the protective covers .....	10
Connect the cooling water .....	11
Connect the power pack .....	11

### OPERATING

Protective equipment .....	12
General safety precautions .....	12
Basic working techniques .....	17
Transport and storage .....	17

### STARTING AND STOPPING

Before starting .....	18
Starting .....	18
Work procedure .....	19
Stopping .....	19

### MAINTENANCE

General .....	20
Daily maintenance .....	20
Service .....	20

### TECHNICAL DATA

Technical data .....	21
Speed and wire speed .....	21
Recommended diamond wire .....	21

### EC DECLARATION OF CONFORMITY

EC Declaration of Conformity .....	22
------------------------------------	----

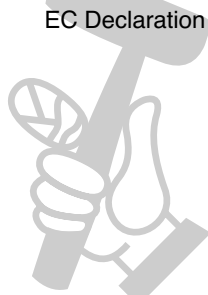

# PRESENTATION

## Dear Customer,

Thank you for choosing a Husqvarna product!

It is our wish that you will be satisfied with your product and that it will be your companion for a long time. A purchase of one of our products gives you access to professional help with repairs and services. If the retailer who sells your machine is not one of our authorised dealers, ask him for the address of your nearest service workshop.

This operator's manual is a valuable document. Make sure it is always at hand at the work place. By following its content (using, service, maintenance etc.) the life span and the second-hand value of the machine can be extended. If you will sell this machine, make sure that the buyer will get the operator's manual.

## More than 300 years of innovation

Husqvarna AB is a Swedish company based on a tradition that dates back to 1689, when the Swedish King Charles XI ordered the construction of a factory for production of muskets. At that time, the foundation was already laid for the engineering skills behind the development of some of the world's leading products in areas such as hunting weapons, bicycles, motorcycles, domestic appliances, sewing machines and outdoor products.

Husqvarna is the global leader in outdoor power products for forestry, park maintenance and lawn and garden care, as well as cutting equipment and diamond tools for the construction and stone industries.

## Owner responsibility

It is the owner's/employer's responsibility that the operator has sufficient knowledge about how to use the machine safely. Supervisors and operators must have read and understood the Operator's Manual. They must be aware of:

- The machine's safety instructions.
- The machine's range of applications and limitations.
- How the machine is to be used and maintained.

National legislation could regulate the use of this machine. Find out what legislation is applicable in the place where you work before you start using the machine.

## The manufacturer's reservation

Subsequent to publishing this manual Husqvarna may issue additional information for safe operation of this product. It is the owner's obligation to keep up with the safest methods of operation.

Husqvarna AB has a policy of continuous product development and therefore reserves the right to modify the design and appearance of products without prior notice.

For customer information and assistance, contact us at our website: [www.husqvarna.com](http://www.husqvarna.com)

## Design and features

Values such as high performance, reliability, innovative technology, advanced technical solutions and environmental considerations distinguish Husqvarna's products. Safe operation of this product requires the operator to read this manual carefully. Ask your dealer or Husqvarna should you need more information.

Some of the unique features of your product are described below.

### Combination saw

CS 10 is a combination saw with a wall saw as its driving source. Existing equipment can be used to drive the wire saw.

This machine is only intended for use together with Husqvarna WS 440 HF + PP 440 HF or WS 482 HF + PP 480 HF.

### Swivel pulleys

The open swivel pulleys are used as the incoming and outgoing pulley on the saw. They can swivel along the cutting line or be set to fixed position.

### Large magazine capacity

Max. wire through the saw is 11,7 m (38 ft) and the magazine capacity is 10 m (33 ft).

### Right or left handed setup

The saw can be assembled in a right or a left position. This is useful when you need to cut close to corners.

# PRESENTATION

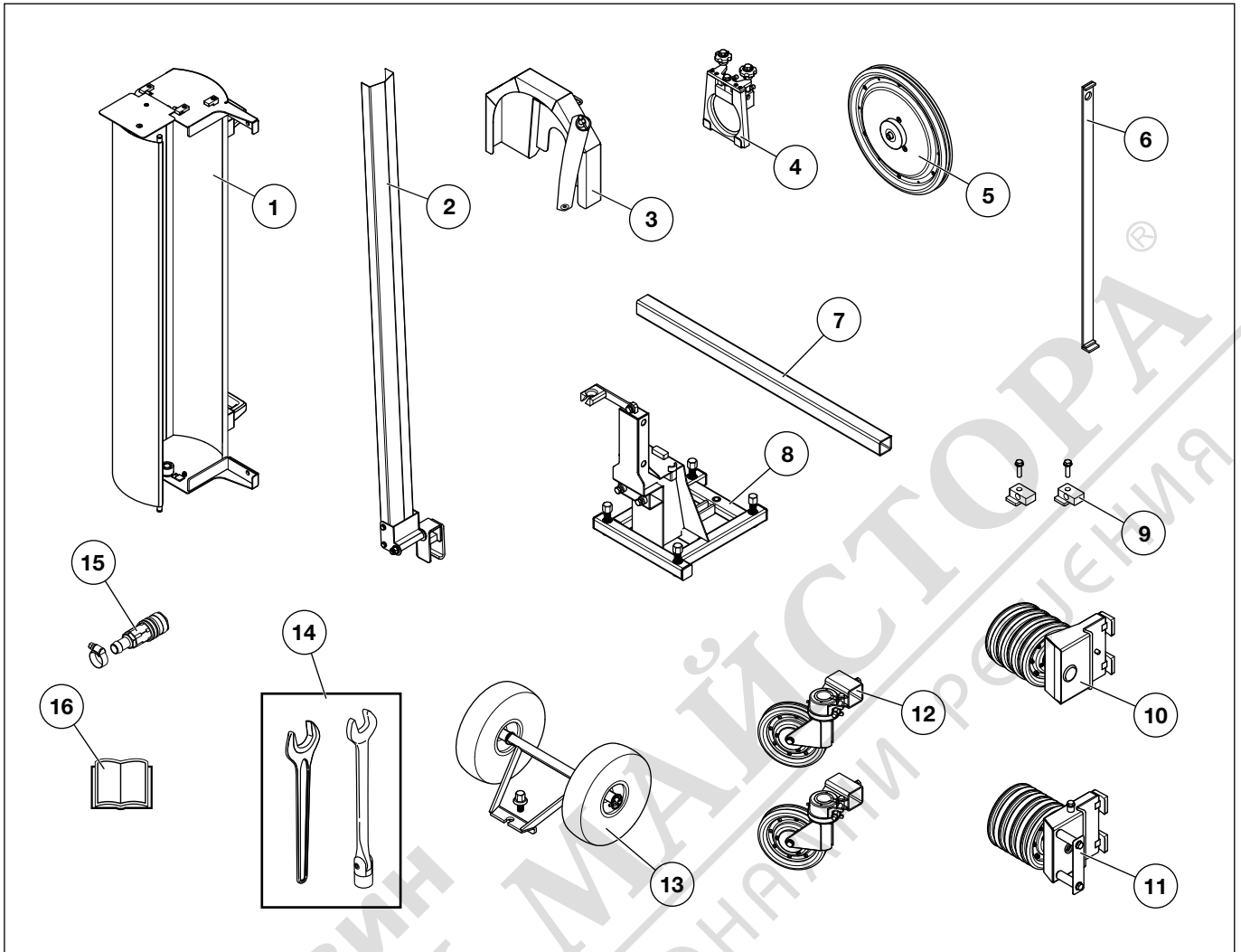

## What is what on the machine?

- |                      |                            |
|----------------------|----------------------------|
| 1 Wheel guard        | 9 Mounting, magazine cover |
| 2 Wire guard         | 10 Upper magazine          |
| 3 Drive pulley guard | 11 Lower magazine          |
| 4 Guard holder       | 12 Swivel pulleys          |
| 5 Drive pulley       | 13 Transport wheels        |
| 6 Drill fixture      | 14 Tool kit                |
| 7 Beam               | 15 Water connector         |
| 8 Base plate         | 16 Operator's manual       |

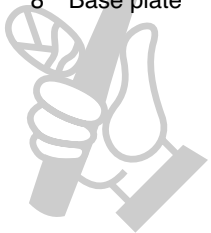

# MACHINE'S SAFETY EQUIPMENT

## General



**WARNING! Never use a machine that has faulty safety equipment! If your machine fails any checks contact your service agent to get it repaired.**

This section describes the machine's safety equipment, its purpose, and how checks and maintenance should be carried out to ensure that it operates correctly.

This machine is used in combination with other products. Please read the manual provided with the products carefully and make sure you understand the instructions before using the machine.

## Protective covers



**WARNING! Never use the machine without a guard nor with a defective guard. Always check that the guards are correctly fitted before starting the machine.**

The protective covers are designed to protect from accidental contact with the cutting equipment and to reduce the risk of accidents in case of a broken wire.

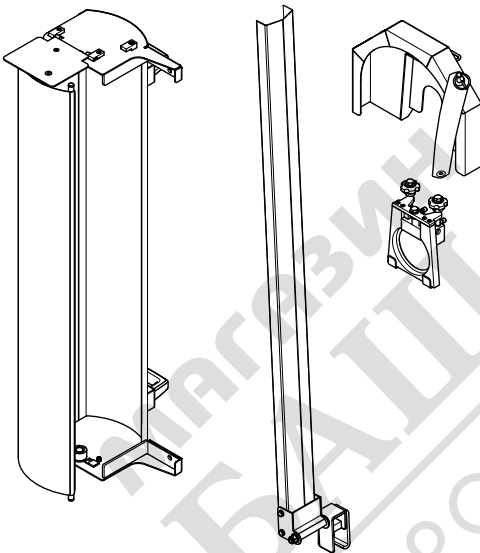

## Inspection of the protective covers



**WARNING! Shut down the machine and disconnect the power plug.**

- Check the protective covers for cracks or other damages. Replace damaged covers.

# ASSEMBLING AND ADJUSTMENTS

## General



**WARNING!** Always position the saw so that you can stand without the risk of being hit by a broken wire. Ensure that no unauthorised persons can access the working area while cutting. Being hit by a broken wire can result in death or serious personal injury.

Cutting needs to be planned carefully before assembling the saw so that it can be performed as easily as possible.

- The saw can both be mounted on the wall and standing on the ground.
- The saw can be assembled in a right or a left position. This is useful when you need to cut close to corners.

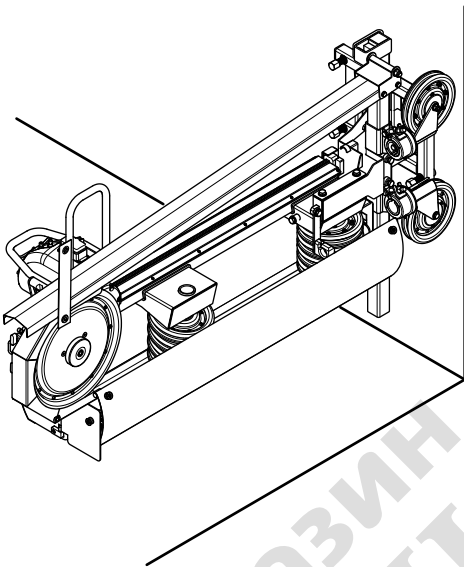

- It may be necessary to drill holes to thread the wire through the material to be cut.

## Use with existing track

When used with an existing track some adjustments need to be made.

- Remove the end stops.

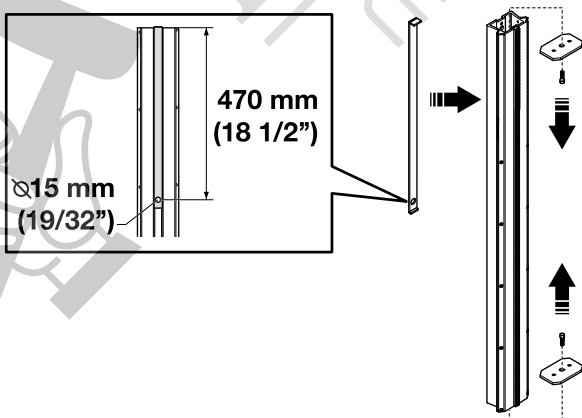

- Drill a 15 mm (19/32") hole, 470 mm (18 1/2") from the top end of the rail. Use the supplied drill fixture. The hole is needed when mounting the upper magazine.

## Secure the base plate

- Position the saw in an appropriate position in front of the planned cut.
- Secure the saw with an anchor bolt.
- The distance from cutting line to bolt is 306 mm (12").

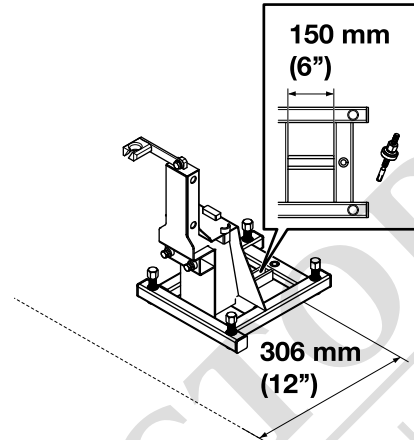

- When cutting vertical cuts with the saw mounted on the wall, the smallest distance from ground to bolt is 615 mm (24").

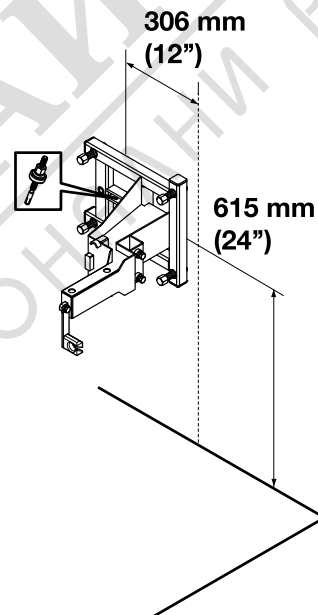

- When the base plate is anchored, screw down the adjuster feet so that the saw stands firmly.

# ASSEMBLING AND ADJUSTMENTS

## Assembling the saw

- Mount the beam on the base plate.

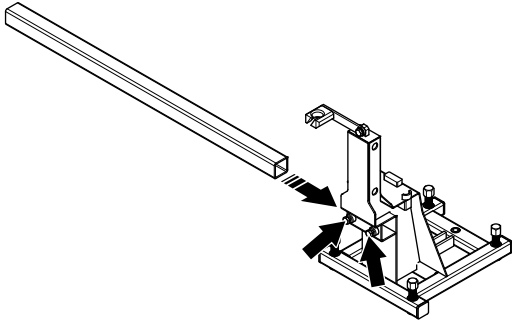

- Mount the swivel pulleys on the beam. The swivel pulleys can be set to a fixed position by tightening the nut.

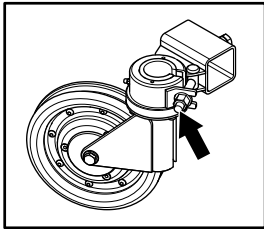
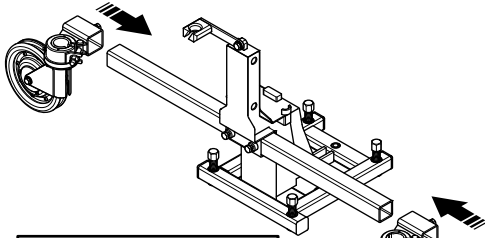

- Mount the lower magazine on the bottom plate. It can be mounted on both the right and the left side.

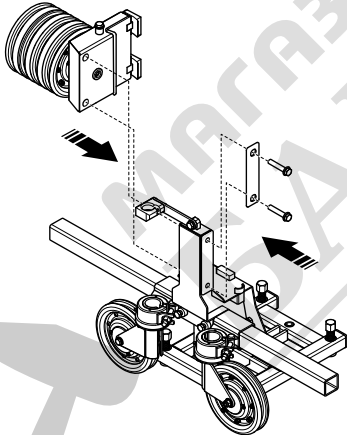

- Mount the brackets for the magazine cover on the rail.

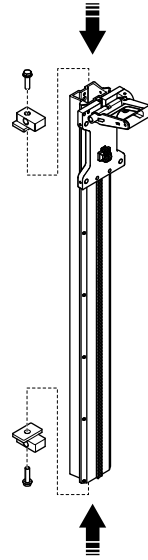

- Mount the rail in the mounting on the lower magazine. The drilled hole for mounting the upper magazine should face upwards.

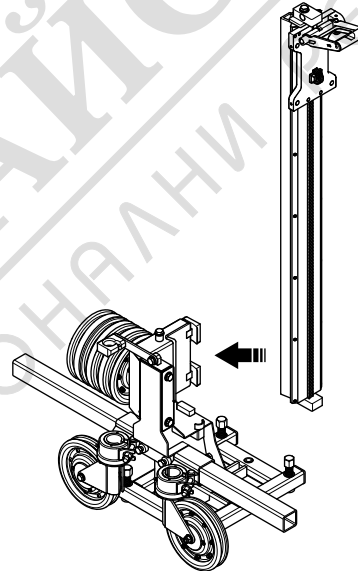



# ASSEMBLING AND ADJUSTMENTS

- Mount the saw motor in the saw carriage.

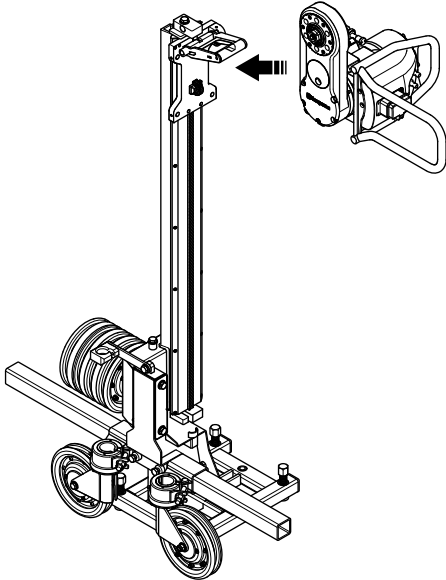

**WARNING!** The cutting arm should always point in the same direction as the rail. The depth feeding function must not be used when sawing with a wire. Carelessness can result in serious personal injury or even death.

**NOTICE!** Ensure that the plastic cover on the saw is pointed upwards when the saw is wall mounted, in order to prevent water and dirt from accumulating inside the cover.

- Mount the guard bracket on the saw motor. Screw the fixing knobs down to lock the guard bracket.

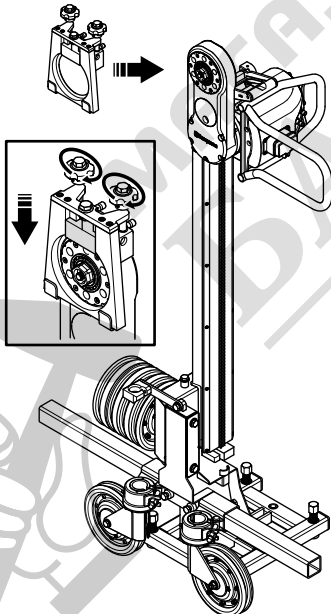

- Mount the drive wheel on the saw motor. Fasten the locking screw to lock the drive wheel.

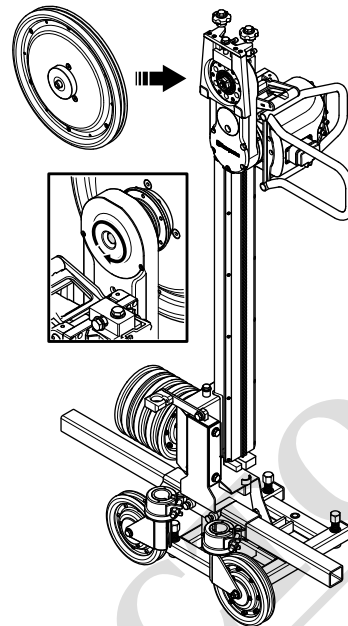

- Mount the upper magazine on the rail. Align the pin on the magazine mounting with the hole on the rail.

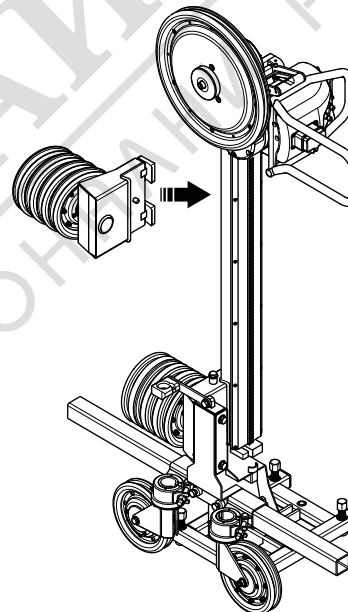

# ASSEMBLING AND ADJUSTMENTS

## Thread the wire

**NOTICE!** A used wire must always be run in the same direction, as it was previously run in order to prevent unnecessary wear.

- Drive the saw carriage down as far as possible.
- Place the wire around the work piece, possibly through the predrilled holes and back to the saw.
- At min. wire through the saw, 1.7 m (6 ft), only place wire over the drive wheel.

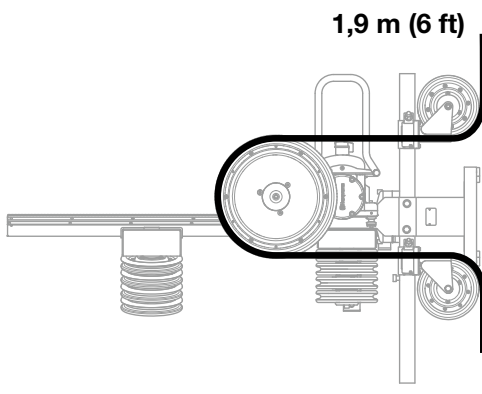

- As the cutting goes along, thread the wire through a suitable number of wheel pairs in the magazine. Max. wire through the saw is 11,3 m (37 ft) and the magazine capacity is 10 m (33 ft).

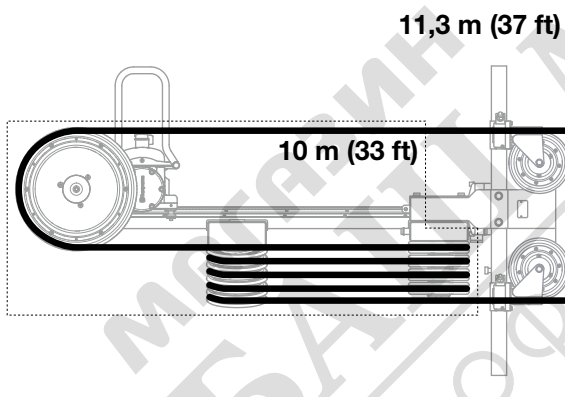

- Before the joints on the wire are connected, the wire should be twisted 1 to 2 turns per metre wire used. It is important to twist the wire in the same direction as it is spun. This is to give as even wear as possible on the wire's diamond segments. A closed wire does not need to be split before you thread it through the machine.

## Assemble the protective covers

- Thread the drive wheel guard over the guard bracket. Fasten the guard with the bail.

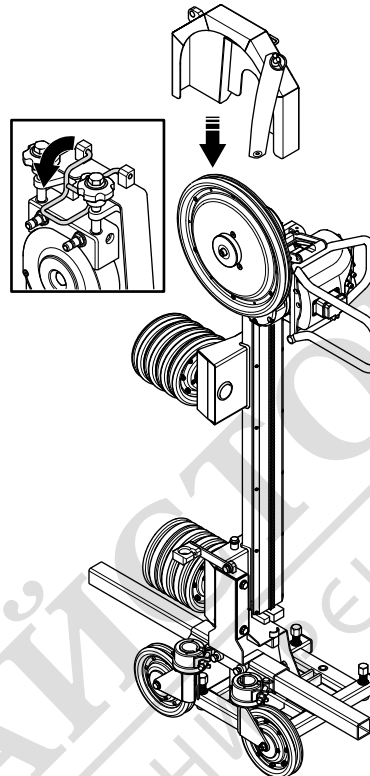

- Mount the magazine cover in the mountings.

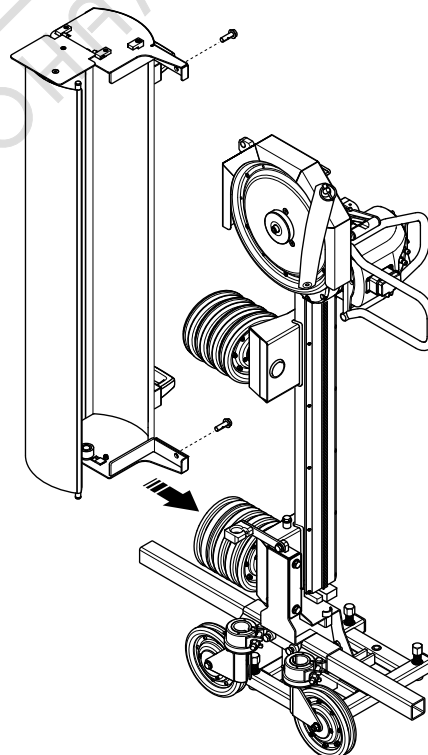

# ASSEMBLING AND ADJUSTMENTS

- The magazine cover can be locked in closed and opened position using the rubber strap.

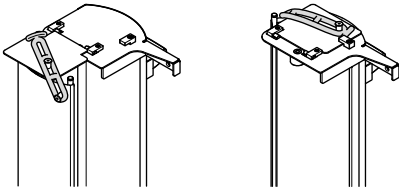

- Mount the wire guard on the beam and through the bracket on the drive wheel guard.

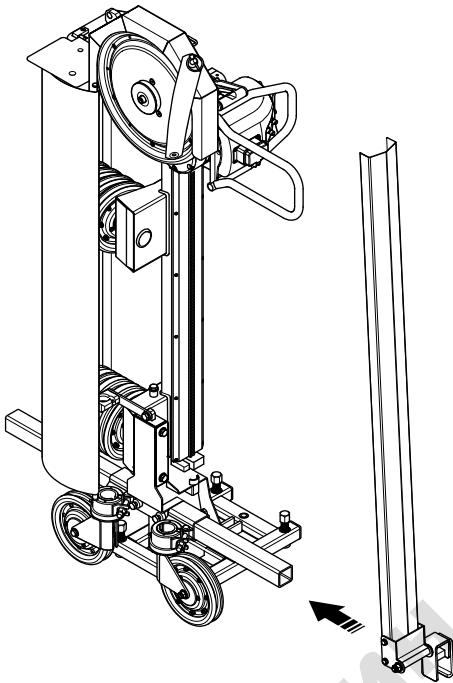

## Connect the cooling water

- Connect a water hose from the saw motor to one of the connectors on the guard bracket.

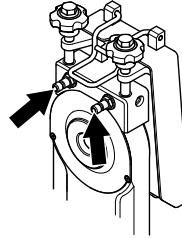

- The water cools off the cutting arm.
- From the other connector on the guard bracket you can lead the water through a water hose or a water lance to cool off the wire.
- The water spears are then placed where the wire enters the concrete. In this way the wire takes water with it into the cut, which results in the concrete dust binding and that the wire is cooled efficiently.

**NOTICE!** In order for the water to cool the wire as intended during cutting, it is essential to adjust the position of the cooling water as the material is cut. Remember to always stop the machine when you do this.

## Connect the power pack

- See instructions in the operator's manual for the saw motor and the power pack in question.

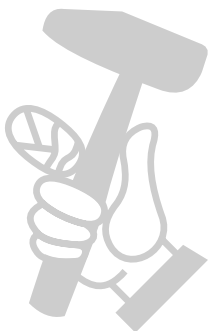

# OPERATING

## Protective equipment

### General

Do not use the machine unless you are able to call for help in the event of an accident.

### Personal protective equipment

You must use approved personal protective equipment whenever you use the machine. Personal protective equipment cannot eliminate the risk of injury but it will reduce the degree of injury if an accident does happen. Ask your dealer for help in choosing the right equipment.



**WARNING! The use of products such as cutters, grinders, drills, that sand or form material can generate dust and vapours which may contain hazardous chemicals. Check the nature of the material you intend to process and use an appropriate breathing mask.**



**WARNING! Long-term exposure to noise can result in permanent hearing impairment. So always use approved hearing protection. Listen out for warning signals or shouts when you are wearing hearing protection. Always remove your hearing protection as soon as the engine stops.**



**WARNING! There is always a risk of crush injuries when working with products containing moving parts. Wear protective gloves to avoid body injuries.**

Always wear:

- Protective helmet
- Hearing protection
- Protective goggles or a visor
- Breathing mask
- Heavy-duty, firm grip gloves.
- Tight-fitting, heavy-duty and comfortable clothing that permits full freedom of movement.
- Boots with steel toe-caps and non-slip sole.

Be careful as clothing, long hair, and jewellery can get caught in moving parts.

### Other protective equipment



**WARNING! Sparks may appear and start a fire when you work with the machine. Always keep fire fighting equipment handy.**

- Fire fighting equipment
- Always have a first aid kit nearby.

## General safety precautions

This section describes basic safety directions for using the machine. This information is never a substitute for professional skills and experience.

- Please read the operator's manual carefully and make sure you understand the instructions before using the machine.
- This machine is used in combination with other products. Please read the manual provided with the products carefully and make sure you understand the instructions before using the machine.
- Keep in mind that the operator is responsible for accidents or hazards occurring to other people or their property.
- All operators shall be trained in the use of the machine. The owner is responsible for ensuring that the operators receive training.
- The machine must be kept clean. Signs and stickers must be fully legible.



**WARNING! The machine can be a dangerous tool if used incorrectly or carelessly, which can cause serious or fatal injury to the operator or others.**

Never allow children or other persons not trained in the use of the machine to use or service it. Never allow anyone else to use the machine without first ensuring that they have read and understood the contents of the operator's manual.

Never use the machine if you are fatigued, while under the influence of alcohol or drugs, medication or anything that could affect your vision, alertness, coordination or judgement.

There is always a risk of shocks from electrically powered machines. Avoid unfavourable weather conditions and body contact with lightning conductors and metal objects. Always follow the instructions in the Operator's manual to avoid damage.



**WARNING! Unauthorized modifications and/or accessories may lead to serious injury or death to the user or others.**

Do not modify this product or use it if it appears to have been modified by others.

Never use a machine that is faulty. Carry out the safety checks, maintenance and service instructions described in this manual. Some maintenance and service measures must be carried out by trained and qualified specialists. See instructions under the Maintenance heading.

Always use genuine accessories.

# OPERATING

## Always use common sense

It is not possible to cover every conceivable situation you can face. Always exercise care and use your common sense. If you get into a situation where you feel unsafe, stop and seek expert advice. Contact your dealer, service agent or an experienced user. Do not attempt any task that you feel unsure of!

## Work area safety



**WARNING! The safety distance to all moving parts is a minimum of 1,5 m. You are responsible to ensure that animals and onlookers are not within the working area.**

- Observe your surroundings to ensure that nothing can affect your control of the machine. Never leave the machine unsupervised with the motor running.
- Do not use the machine in bad weather, such as dense fog, heavy rain, strong wind, intense cold, etc. Working in bad weather is tiring and often brings added risks, such as icy ground.
- Ensure that the working area is sufficiently illuminated to create a safe working environment.
- Never start to work with the machine before the working area is clear and you have a firm foothold.
- Make sure that no pipes or electrical wires are routed in the work piece or in the working area.
- Make sure that electrical cables within the working area are not live.

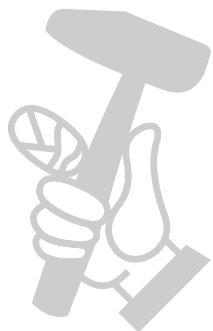

# OPERATING

## The machine's risk area

Nobody is permitted to be within the machine's risk area when work is underway. This also applies for the operator.

Wall cutting

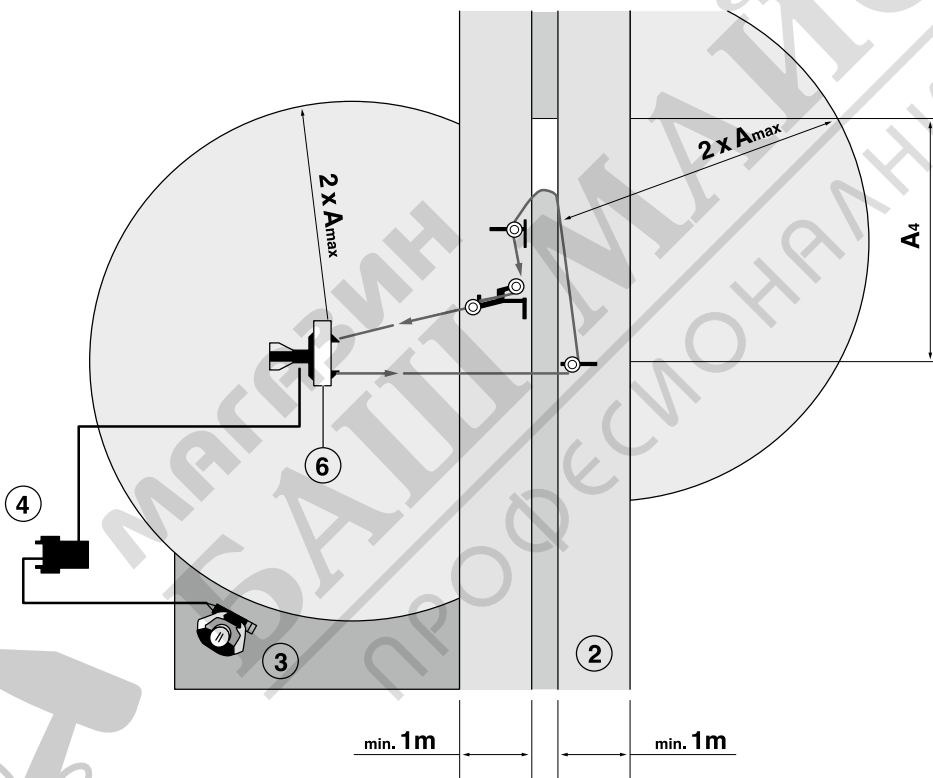
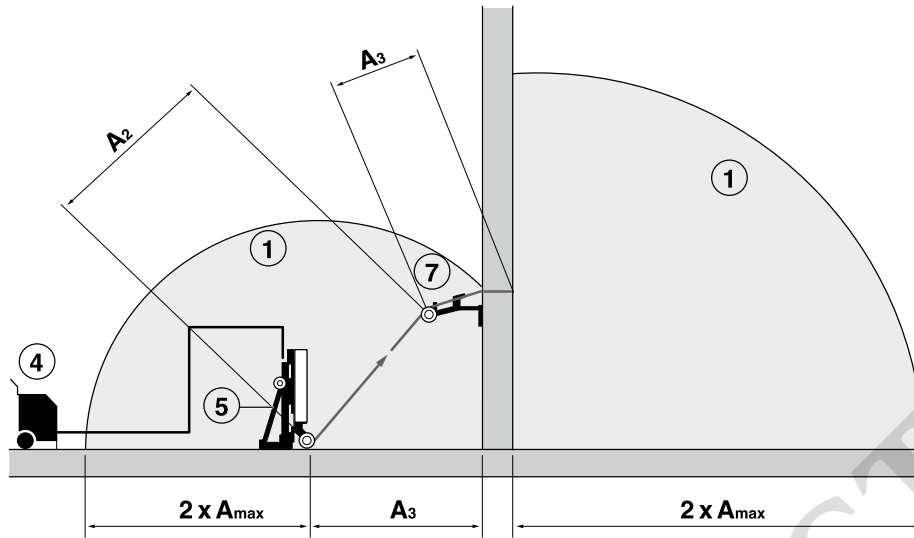

( $A_{max}$ ) Largest free running wire section ( $A_1$ - $A_4$ )

- 1 Risk area
- 2 Risk area of the horizontal projection of the wire towards the operator
- 3 Recommended operator position
- 4 Power pack
- 5 Wire drive unit
- 6 Wire guard
- 7 Pulley wheels

# OPERATING

Cutting with additional pulley wheels

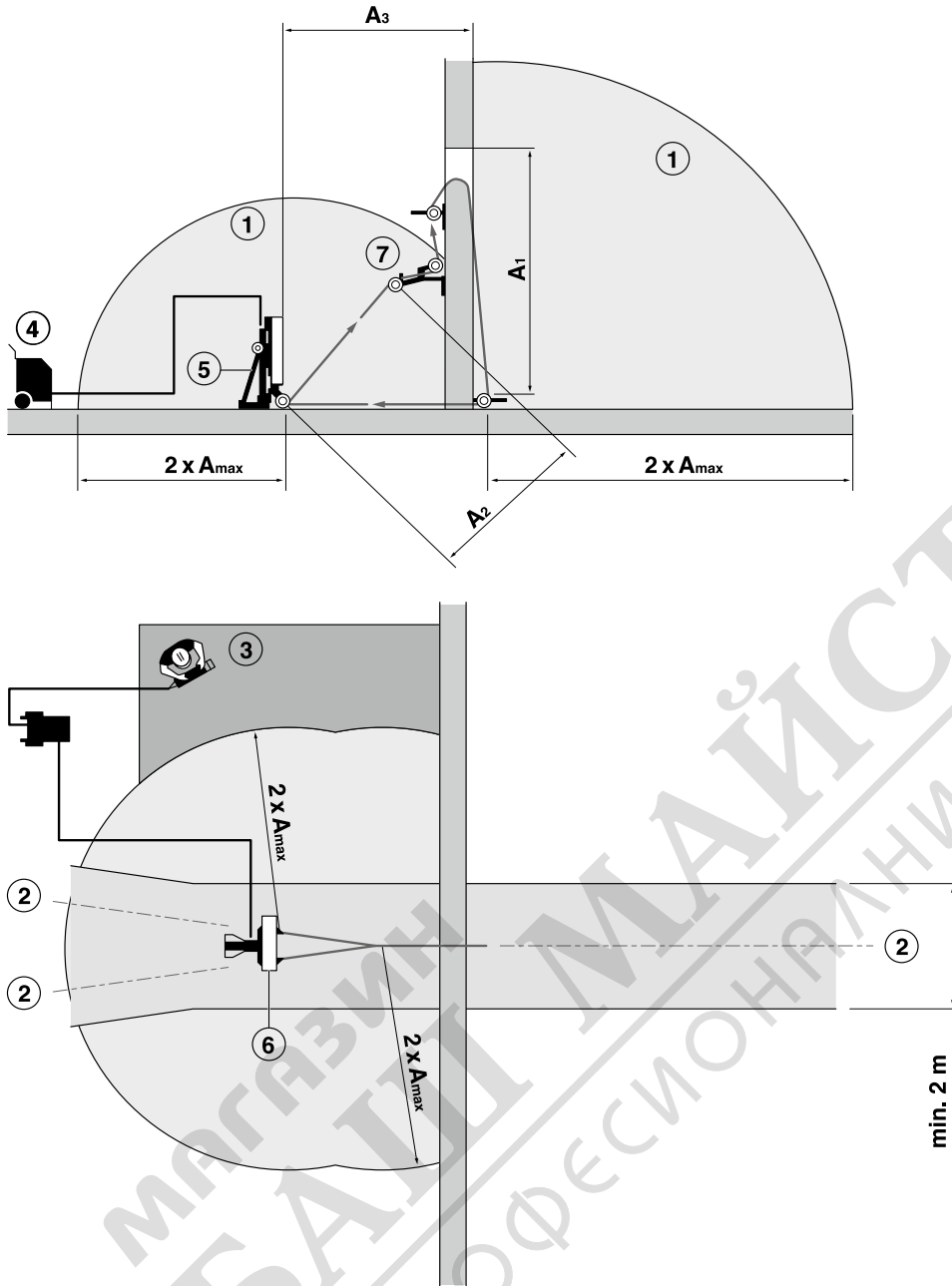

( $A_{max}$ ) Largest free running wire section ( $A_1$ - $A_3$ )

- 1 Risk area
- 2 Risk area of the horizontal projection of the wire towards the operator
- 3 Recommended operator position
- 4 Power pack
- 5 Wire drive unit
- 6 Wire guard
- 7 Pulley wheels

# OPERATING

## Floor cutting

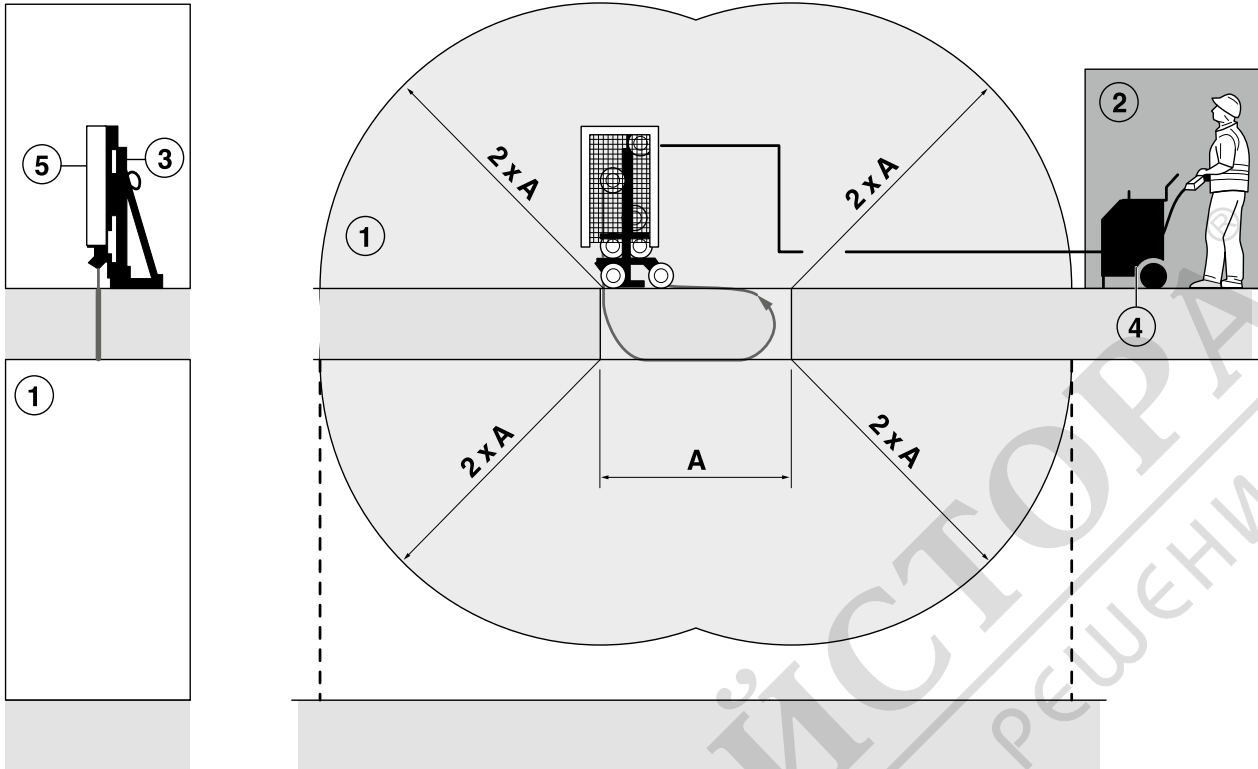

(A) Largest free running wire section

- 1 Risk area
- 2 Recommended operator position
- 3 Wire drive unit
- 4 Power pack
- 5 Wire guard

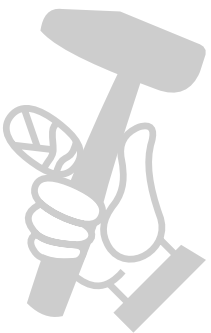



---

# OPERATING

---

## Basic working techniques

- This machine is only intended for use together with Husqvarna WS 440 HF + PP 440 HF or WS 482 HF + PP 480 HF.
- This machine is designed for and intended for sawing concrete, brick and different stone materials. All other use is improper.
- The machine is intended for use in industrial applications by experienced operators.
- Never use the machine if you are fatigued, while under the influence of alcohol or drugs, medication or anything that could affect your vision, alertness, coordination or judgement.
- Keep all parts in good working order and ensure that all fixtures are properly tightened.
- Check that the guards are mounted correctly and do not show any signs of damage. Never cut without using the guard.
- Only use wire recommended by the manufacturer. Ask your dealer for help in choosing the right product.
- Never use worn or damaged wire.
- A used wire must always be run in the same direction, as it was previously run in order to prevent unnecessary wear.
- Never cut without using the cooling water. A poorly cooled wire can result in the segments overheating, which results in greater wear. In the worst case scenario, segments can come loose from the wire and injure persons close to the saw.
- Clearly mark out all cuts to be made before you start sawing, plan these so they can be carried out without danger to persons or the machine.
- Firmly secure or anchor concrete blocks before cutting. The heavy weight of cut material can cause both extensive damage to the machine and serious personal injury if it cannot be moved under controlled conditions.
- Never leave the machine unsupervised with the motor running.
- Never saw in such a way that you cannot easily reach the emergency stop on the remote control or on the power pack. See power pack manual.
- Observe care when lifting. You are handling heavy parts, which imply the risk of pinch injuries or other injuries.

## Transport and storage

- Always switch off the power pack and pull out the electric cable before moving the equipment.
- Secure the equipment during transportation in order to avoid transport damage and accidents.
- Store the equipment in a lockable area so that it is out of reach of children and unauthorized persons.

# STARTING AND STOPPING

## Before starting



**WARNING!** The machine requires software for wire cutting to be installed in the remote control and in the power pack. Equipment that does not have this software must be submitted to an authorized servicing dealer for upgrading. The machine must not be used until new software has been installed.

Please read the operator's manual carefully and make sure you understand the instructions before using the machine.

This machine is used in combination with other products. Please read the manual provided with the products carefully and make sure you understand the instructions before using the machine.

Wear personal protective equipment. See instructions under the "Personal protective equipment" heading.

Make sure no unauthorised persons are in the working area, otherwise there is a risk of serious personal injury.

- Check that the machine is assembled correctly and do not show any signs of damage. See instructions in the section "Assembling and adjustments".
- Perform daily maintenance. See instructions in the section "Maintenance".

## Starting

- Follow the instructions for starting in the manual supplied with the power pack.

## Addition to starting instructions for wire cutting

- **WS 482 HF:** The remote control display shows "SELECT GEAR". Select "Gear 2". Confirm with "OK".
- Go to the option "DRIVING MODE" in the operating menu by navigating with the arrow keys.
- Select "Wire". Confirm with "OK".

## Align the cutting arm



**WARNING!** When the cutting arm is aligned with the rail the depth feeding control must not be used anymore. Carelessness can result in serious personal injury or even death.

- Before starting to cut you must position the cutting arm so that it is aligned with the rail. You do this with the depth feeding control. When the cutting arm is aligned with the rail the depth feeding control must not be used anymore.

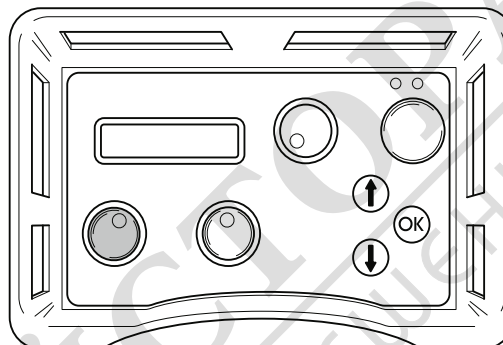

During operation the depth feeding control is disabled.

## Tension the wire



**WARNING!** Do not over-tension the wire! An over-tensioned wire will brake the rotation and can result in the wire breaking. Carelessness can result in serious personal injury or even death.

- Check that the wire is seated correctly in all the wheels.
- Tension the wire against the cutting line by turning the travel feeding control. The wire should rest against all wheels and against the work piece.

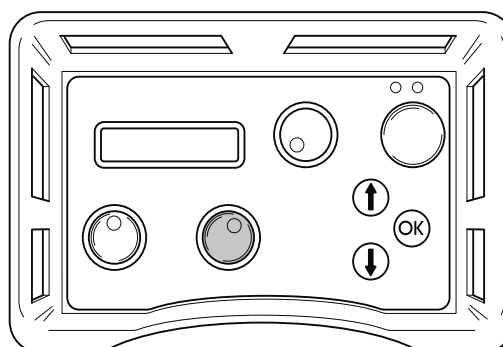

# STARTING AND STOPPING

## Start the rotation

- Hold down the green start button while turning the rotation control clockwise to start the rotation. Turn the control gently. Start with low rotating speed.
- Check that the rotation is turning in the desired direction. Under the heading **BLADE ROTATION** in the operations menu the rotation can be set to the desired direction.

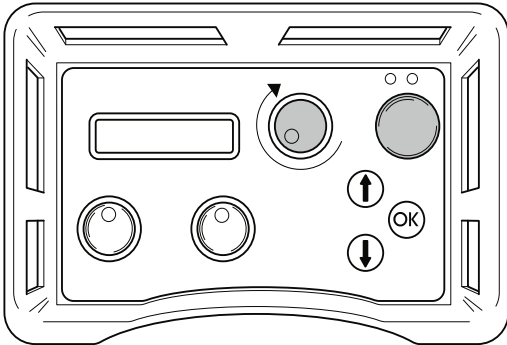

If the drive wheel cannot start the rotation of the wire the reason may be one of the following:

- The wire is too tight. Ease the tension.
- The guide wheels are not properly adjusted. Adjust the guide wheels.
- The contact surface against the work piece is too large. Add a pulley wheel.

## Work procedure



**WARNING! Do not cut continuously on max. power output (100%)! This can cause an over-tension of the wire that will cause it to break. Carelessness can result in serious personal injury or even death.**

- When the wire has engaged in the cut, you can slowly increase the speed until the desired level is obtained. See the table "Speed and wire speed" under the heading "Technical data".

- On the display you can check the output in percentage. During cutting, the value is generally between 50 and 100%.

The power output used for cutting depends on factors such as the saw unit used, how large the wire's contact surface against the work piece is, chosen output mode etc.

Be careful and rather use a lower output to decrease the risk of the wire breaking.

- Keep the wire tensioned as the material is cut off.

## Storing the wire

When the saw unit has reached its end position on the rail, the wire must be stored.

- Stop the rotation.
- Move the saw to the starting position, at the far end against the bottom plate.
- Put the wire around the magazine wheels and adjust the guide wheel closest to the outgoing magazine wheel.

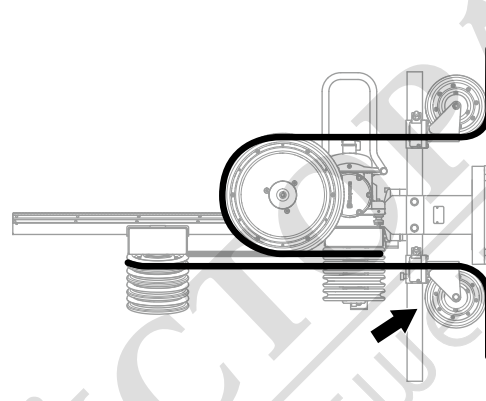

- When the cut is completed the guide wheels should be adjusted so that the wire can be caught once it is through the work piece.

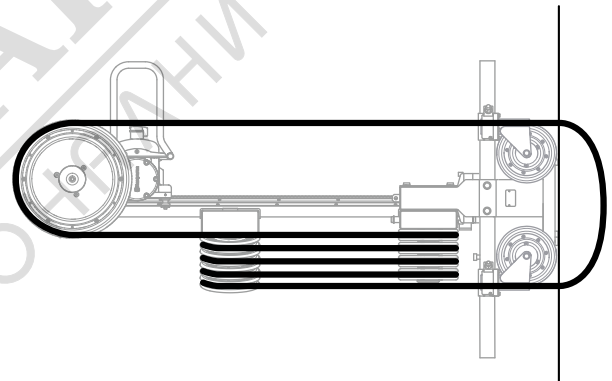

## Stopping

- Turn the rotation and travel feeding controls to their zero positions.
- Follow the instructions in the manual supplied with the power pack.

# MAINTENANCE

## General



**WARNING!** The user must only carry out the maintenance and service work described in this Operator's Manual. More extensive work must be carried out by an authorized service workshop.

Shut down the machine and disconnect the power plug.

Wear personal protective equipment. See instructions under the "Personal protective equipment" heading.

The life span of the machine can be reduced and the risk of accidents can increase if machine maintenance is not carried out correctly and if service and/or repairs are not carried out professionally. If you need further information please contact your nearest service workshop.

## Daily maintenance

- Check that the machine's safety equipment is undamaged. See instructions in the section "Machine's safety equipment".
- Clean the outside of the machine. Do not use a high pressure washer to clean the saw.
- Check that the rubber in the guide wheels is in place and not worn.
- Check the bearings. Rotate the wheels by hand and make sure they rotate freely.

## Service

In addition to the daily maintenance such as cleaning and lubrication, the machine must be serviced. After 50 hours of cutting, the machine should be serviced at an accredited Husqvarna workshop. The saw should then be serviced after every 100 hours of operation. The service is important so that as the user you have a machine that works as effectively as possible for a long time.

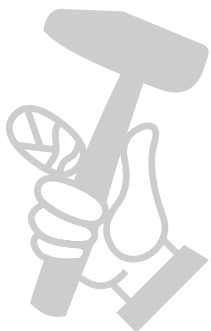

# TECHNICAL DATA

## Technical data

### Power - max, kW/hp

WS 440 HF	13/17.5
WS 482 HF	19/25.6

### Speed, rpm

0-1200

### Starting torque, Nm

WS 440 HF	100
WS 482 HF (Gear 2)	160

### Magazine capacity, m/ft

10/33

### Wire capacity, m/ft

1,9-11,3 / 6-37

### Weight, kg/lbs

WS 440 HF	135/298
WS 482 HF	138 / 304

### Direction of rotation

Both directions

### Degree of protection

IP 65

### Wire speed (at 1200 rpm), m/s / ft/s

24/79

### Noise emissions (see note 1)

Sound power level, measured dB (A)	99
Sound power level, guaranteed $L_{WA}$ dB (A)	100

### Sound levels (see note 2)

Sound pressure level at the operators ear, dB(A)	86
--	----

Note 1: Noise emissions in the environment measured as sound power ( $L_{WA}$ ) in conformity with EN 15027/A1.

Note 2: Noise pressure level according to EN 15027/A1. Reported data for noise pressure level has a typical statistical dispersion (standard deviation) of 1.0 dB(A).

## Speed and wire speed

Spindle speed, rpm	Wire speed, m/s	Wire speed, ft/s
1000	20	66
1100	22	72
1200	24	79

## Recommended diamond wire

Model	Abrasive materials	Lime concrete	Reinforcement degree		
			Low	Medium	High
C 710	-	-	Good	Optimal	Good
C 760	Acceptable	Good	Optimal	Good	Acceptable
C 1000	Good	Good	Good	Optimal	Good
C 1200	Good	Acceptable	Acceptable	Good	Optimal

# TECHNICAL DATA

## EU Declaration of Conformity

### (Applies to Europe only)

We, **Husqvarna AB**, SE 561 82 Huskvarna, SWEDEN, Tel. +46 36 146500 declare on our sole responsibility that the product:

Description	Wall saw
Brand	HUSQVARNA <sup>®</sup>
Type / Model	CS 10
Identification	Serial numbers dating from 2018 and onwards

complies fully with the following EU directives and regulations:

Directive/Regulation	Description
2006/42/EC	"relating to machinery"
2011/65/EU	"relating to restriction of hazardous substances"

and that harmonized standards and/or technical specifications are applied as follows;

EN ISO 12100:2010

EN 15027/A1:2009

Partille, 3 May 2018

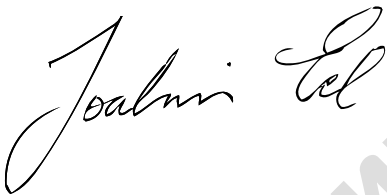

Joakim Ed  
Global R&D Director  
Responsible for technical documentation

