



**GB**

**Operator's manual**

Please read the operator's manual carefully and make sure you understand the instructions before using the machine.

**ES**

**Manual de instrucciones**

Lea detenidamente el manual de instrucciones y asegúrese de entender su contenido antes de utilizar la máquina.

**FR**

**Manuel d'utilisation**

Lire attentivement et bien assimiler le manuel d'utilisation avant d'utiliser la machine.



**FS 513**

**FS 520**

**FS 524**

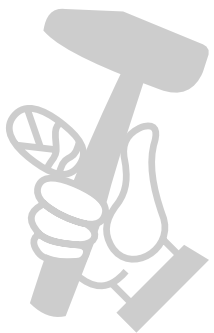

МАГАЗИН  
**БАШ МАЙСТОРА**<sup>®</sup>  
ПРОФЕСИОНАЛНИ РЕШЕНИЯ

# CONTENTS and INTRODUCTION

Section	Contents	Page
Contents & Introduction.....		3
Symbols and Decals.....		4-8
Safety Instructions.....		9-12
Parts Identification (What Is What).....		14-16
Assembly.....		17-21
Operation .....		22-27
Maintenance & Lubrication .....		28-32
Trouble Shooting Guide.....		33
Wiring diagram.....		34-38
Technical Data.....		39-40
Accessories.....		41
Conformity Certificates.....		42
Contact Information.....		43

## Introduction

Thank you for purchasing your new machine from Husqvarna Construction Products. We have provided important safety messages in this manual and on the machine. Please read these messages carefully. A safety message alerts you to potential hazards that could hurt you or others. Each safety message is preceded by a symbol or the safety alert symbol (▲) and one of two words, **WARNING**, or **CAUTION**.

These signal words mean:

**▲ WARNING:** Indicates a hazardous situation which, if not avoided **COULD** result in death or serious injury.

**▲ CAUTION:** Indicates a hazardous situation, which, if not avoided, **COULD** result in minor or moderate injury. It may also be used to alert against unsafe practices.

Each message tells you what the hazard is, what can happen, and what you can do to avoid or reduce injury. Other important messages are preceded by the word **NOTICE**.

**NOTICE** means:

**NOTICE:** Indicates a hazardous situation which, if not avoided, could result in property damage. Your machine or other property can be damaged if you don't follow this instruction.

The safety labels should be periodically inspected and cleaned by the user to maintain good legibility at a safe viewing distance. If the label is worn, damaged, or is illegible, it should be replaced.

**▲ WARNING!**



Before operating machine, read and understand this entire operation manual & engine operation manual supplied with engine.

Be familiar with machine before operation!

**Model Identification:** Record machine serial number plate information below for future reference

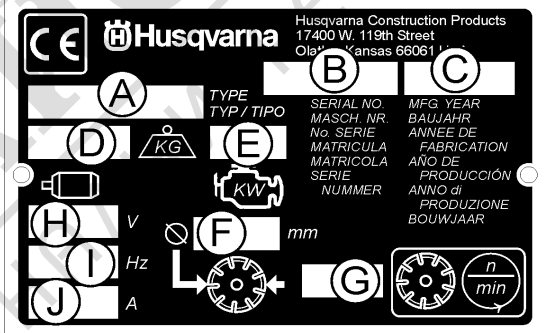
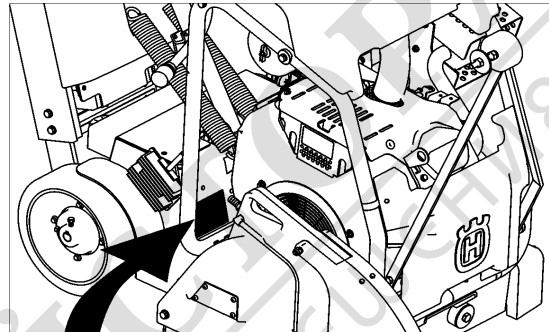

**A. Model:** \_\_\_\_\_

**B. Machine Serial No:** \_\_\_\_\_

**C. Year of Manufacture** \_\_\_\_\_

**D. Mass of Machine (kg)** \_\_\_\_\_

**E. Engine Power (KW)** \_\_\_\_\_

**F. Blade Diameter (mm)** \_\_\_\_\_

**G. Blade Speed (Revolutions / Minute)** \_\_\_\_\_

**H. Electric Motor Voltage (If Equipped)** \_\_\_\_\_

**I. Electric Motor Phase (If Equipped)** \_\_\_\_\_

**J. Electric Motor Amperage (if Equipped)** \_\_\_\_\_

Other information not shown on machine serial plate:

**Engine Serial No:** \_\_\_\_\_

See Engine Operation Manual for location.

**Purchase Date:** \_\_\_\_\_

# SYMBOLS and DECALS



Please read the instructions for use prior to operating the machine for the first time.



This symbol indicates that the machine is in conformance with the applicable European directive.



Mandatory



Indication



Prohibition



Warning Triangle



Wear Eye Protection



Wear Breathing Protection



The use of hearing protection is mandatory



Wear Head Protection



Wear Safety Shoes



Wear Appropriate Clothing



Remove the blade prior to Hoisting, Loading, Unloading and Transporting the Machine.



Emergency Shutdown, Transmission Stop



Use In Well Ventilated Area



Do Not Use In Flammable Areas



Machinery Hazard, Keep hands and Feet Clear.



Muffler Hot. May Cause Burns and / or Ignition of Material. Avoid Contact.



Danger, Poison Exhaust Gas



No Non-working Personnel In Area



No Smoking



Do Not Operate Without Blade Guard in Place



Always Keep All Guards In Place



Water Supply On































Water Supply Off



Water Supply

## SYMBOLS and DECALS

	Blade Water Safety Switch		Electrical Switch-Start
	Engine Coolant Temperature		Repairs Are To Be Done By An Authorized Dealer Only
	Keep Work Area Clean/Well Lit, Remove All Safety Hazards		Headlight
	Dangerously High Noise Level		Diamond Blade
	Pay Extreme Attention to The Care And Protection Of The Machine Before Starting Up		Blade Diameter
	Remove Tools From Area and Machine		Blade Engagement
	Engine Oil Pressure		Pulley diameter
	Oil Required		Number of Revolutions Per Minute, Rotational Speed
	Dipstick, Maintain Proper Oil Level		Blade Flange Diameter
	Lubrication Point		Blade Depth Stop
	High Speed		Cutting Depth Indicator – Depth of Cut
	Low Speed		Parking Brake
	Electrical Switch-Off		Parking Brake Applied
	Electrical Switch-On		Parking Brake Released

## SYMBOLS and DECALS



Machine Mass (Kilograms)



Engine Stop



Positive Battery Terminal



Engine Start

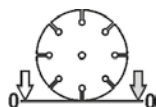

Blade Depth Indicator – Zero



Engine Run



Electric Motor



Disengage to Start Engine (Neutral Start)



Engine

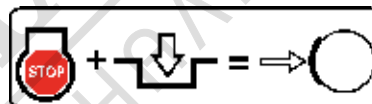

Stop Engine and Engage Transmission to Engage Parking Brake



Engine Speed Revolutions/Minute



Engine Start

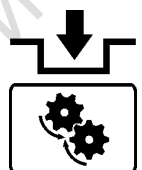

Engage Transmission



Unleaded Fuel Only



Disengage Transmission



# SYMBOLS and DECALS

## FS 513

P/N 542 19 07-08 (2)  
Location: Left and Right Side of Cowl  
(FS 513 Only)



P/N 542 19 07-33  
Location: Front of Cowl

## FS 520

P/N 542 19 07-09 (2)  
Location: Left and Right Side of Cowl  
(FS 520 Only)



P/N 543 85 00-37  
"Blade Guard Arrow (FS 524 - 600mm Only)  
Top of Rear Blade Guard  
(600 mm FS 520-FS 524 Only)

## FS 524

P/N 542 19 07-10 (2)  
Location: Left and Right Side of Cowl  
(FS 524 Only)

### EMISSIONS CONTROL INFORMATION

**HUSQVARNA**  
THIS EQUIPMENT MEETS  
U.S. EPA EVAP STANDARDS

EXEMPT FROM TANK  
PERMEATION STANDARDS  
UNDER 40 CFR 1054.145

FAMILY: BHQCPNHEQA01

578077501

P/N 578077501  
Location: Upper RH Frame  
(FS 520, FS 524 Only)



P/N 542 16 72-98 (2x)  
Location: Left and Right Side  
of Blade Guard (FS 513, 520 Only)

For local service, please contact your local Husqvarna Construction Products representative.

Para efectuar un servicio local, póngase en contacto con su representante local de Husqvarna Construction Products.

Pour toute réparation, contacter le représentant local de Husqvarna Construction Products.

Für Service vor Ort wenden Sie sich bitte an Ihren örtlichen Vertreter von Husqvarna Construction Products.

Neem voor plaatselijke service contact op met uw plaatselijke vertegenwoordiger van de constructieproducten van Husqvarna.

Per assistenza, rivolgersi al rappresentante di zona della Husqvarna Construction Products.

För service på platsen, kontakta din lokala representant för Husqvarna Construction Products.

Para obter serviço técnico local, contactar o representante da Husqvarna Construction Products local.

#### Europa / Europe:

Husqvarna  
Construction Products  
SE-433 81 Partille, Sweden  
Tel: +46 31 94 90 00  
Fax: +46 31 94 90 50

#### Asia Pacific:

Husqvarna  
Construction Products,  
Australia Pty Ltd  
25-31 Kinkaid Avenue,  
North Plympton, Adelaide,  
South Australia 5037  
Tel: +61 (0)8 8375 1000  
Fax: +61 (0)8 8371 0990

#### The Americas:

Husqvarna Construction Products,  
North America  
17400 West 119th Street,  
Olathe, Kansas 66061 USA  
Toll-Free Telephone: 800-288-5040,  
Telephone: 913-928-1300  
Fax: 913-438-7938

P/N 542 19 06-46 Local Service  
Location: Side of Frame



P/N 542 19 05-89  
Location: Depth Gauge

# SYMBOLS and DECALS

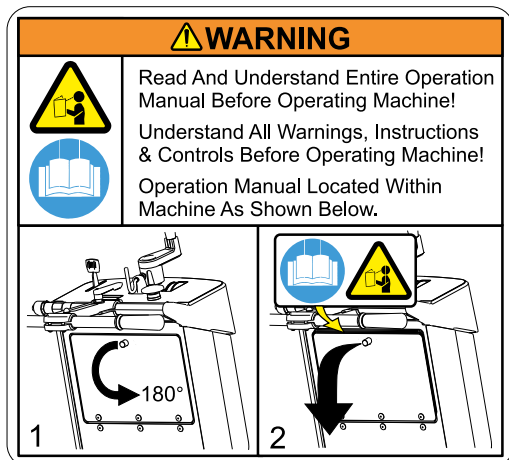

P/N 542 19 05-93  
Location: Rear of Cowl



P/N 542 19 06-17  
Location: Water Tank (If Equipped)



P/N 542 16 90-65  
Location: Top of Belt Guard



P/N 578 01 42-01 **SOUND LEVEL - 109 dBA**  
Location: Upper RH Frame



P/N 542 16 12-35 **PATENT PENDING**  
Location: Upper RH Frame

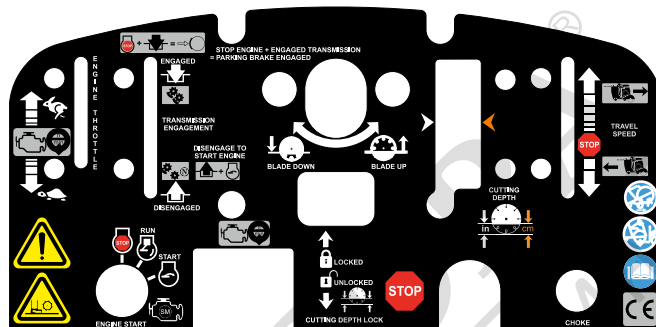

P/N 502 24 01-03  
Location: Top of Cowl, FS 520, FS 524

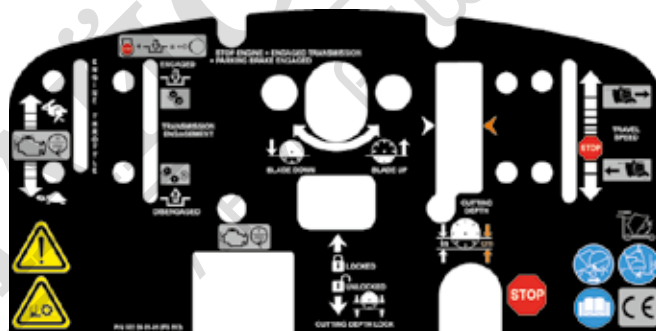

P/N 502 24 01-01  
Location: Top of Cowl, FS 513



P/N 542 19 06-38  
Location: Rear of Cowl





P/N 542 19 06-39  
Location: Frame Near Fuel Fill (FS 520, FS 524)





# SAFETY INSTRUCTIONS

## General use

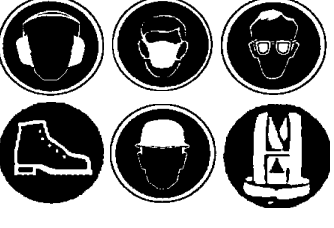
 <b>WARNING!</b>	
	Before operating machine, read and understand this entire operation manual & engine operation manual supplied with engine.
	Be familiar with machine before operation!

	<b>Operator must wear personal protective equipment &amp; clothing appropriate to the work he is doing. Personal protective equipment, such as hearing &amp; eye protection, is mandatory.</b>
---	--

	<b>The working area must be completely clear, well lit and all safety hazards removed.</b>
---	--

	<b>Any persons not involved in the work, should leave the area.</b>
---	---

	<b>WARNING! Do not contact the tool when machine is in operation.</b>
---	---

## Fuel Safety:

	<b>WARNING! Take care when handling fuel. Bear in mind the risk of fire, explosion and inhaling fumes.</b>
---	--

- Only store fuel in containers approved for the purpose.
- Only refuel machine with engine OFF. Never remove fuel cap and fill the fuel tank while the engine is running.
- Always refuel in a well ventilated area.
- Never fill a fuel tank indoors.
- Allow engine to cool before refueling.

	<b>Never fuel machine in vicinity of sparks or flames. Do not use machine in flammable area.</b>
---	--

	<b>Do not smoke while fueling or using the machine.</b>
---	---

- Move machine 10 feet (3 meters) from refueling point before starting engine.
- Never start the machine:
  - 1) If fuel has been spilled on the machine. Wipe off spillage and allow remaining fuel to evaporate.
  - 2) If you have spilled fuel on yourself or your clothes. Use soap and water to wash any part of your body that has come in contact with fuel.
  - 3) If the machine is leaking fuel. Check regularly for leaks from the fuel cap and fuel lines.
- Store and transport machine and fuel so that there is no risk of any leakage or fumes coming into contact with sparks or flames, for example, electrical machinery or electric motors, electrical relays / switches, or boilers.

## DUST WARNING

**Cutting, especially when DRY cutting, generates dust that comes from the material being cut, which frequently contains silica.** Silica is a basic component of sand, quartz, brick clay, granite and numerous other minerals and rocks. Exposure to excessive amount of such dust can cause:

- Respiratory diseases (affecting your ability to breath), including chronic bronchitis, silicosis and pulmonary fibrosis from exposure to silica. These diseases may be fatal;
- Skin irritation and rash; and
- Cancer according to NTP\* and IARC\*

\* National Toxicology Program, International Agency for Research on Cancer

### Take precautionary steps

- Avoid inhalation of and skin contact with dust, mist and fumes;
- Wet cut when feasible, to minimize dust;
- Wear and ensure that all bystanders wear appropriate respiratory protection such as dust masks designed to filter out microscopic particles. (See OSHA 29 CFR Part 1910.1200)

### California Prop 65 Warning:

Use of this product can cause exposure to materials known to the State of California to cause cancer and/or birth defects or other reproductive harm.

## SAFETY INSTRUCTIONS



### WARNING POISON EXHAUST GAS



**THIS SAW IS SHIPPED FROM THE FACTORY WITHOUT A CATALYTIC CONVERTER.** THE ENGINE PRODUCES CARBON MONOXIDE EXHAUST EMISSIONS AND IS **NOT SAFE** FOR USE IN ENCLOSED AREAS. USE OF A CATALYTIC CONVERTER REDUCES THE CARBON MONOXIDE EXHAUST EMISSIONS, BUT STILL IS **NOT SAFE** FOR USE IN ENCLOSED AREAS.

USE ONLY IN WELL-VENTILATED AREAS. WORK SITE AIR QUALITY MUST COMPLY WITH OSHA 29 CFR 1910.1000 PER TABLE Z-1, LIMITS FOR AIR CONTAMINANTS.

MONITOR WORKSPACE AIR QUALITY TO INSURE COMPLIANCE. FAILURE TO COMPLY WILL RESULT IN DANGER TO LIFE AND CAUSE PERMANENT INJURY OR DEATH.

#### General Information

Carbon monoxide (CO) has the distinction of being one of the few commonly encountered industrial gasses that is both highly toxic (poison) and odorless. When inhaled, CO acts as a chemical asphyxiant by preferentially combining with hemoglobin in the blood stream. As a result, the hemoglobin is not able to transport its normal amount of oxygen, which results in under-oxygenation of tissues. Symptoms of low-level CO exposure include headaches, dizziness, confusion, and nausea. **However, loss of consciousness, permanent injury and death may result from continued or more intense exposure.** Because of the health hazards associated with CO inhalation, the Occupational Safety and Health Administration (OSHA) have imposed personal exposure limits. The OSHA exposure limits, which are specified in the 29 CFR 1910.1000 (1998 Revision), allow for a 200 PPM Ceiling Limit and a TWA of 35 PPM per 8-hour shift/40-hr workweek. It is strongly recommended that the OSHA 29 CFR 1910.1000 (Code of Federal Regulations) be consulted for more information on exposure limits for various hazardous materials. If CO Poisoning is suspected immediately remove the victim to fresh air and obtain emergency medical attention.

#### Proper Ventilation:

**THIS SAW IS SHIPPED FROM THE FACTORY WITHOUT A CATALYTIC CONVERTER.** It is important to be aware that saws with catalytic converters reduce CO and hydrocarbon (HC) emissions. The exhaust still contains CO. If the workspace is too confined or under-ventilated, CO may accumulate until it eventually exceeds OSHA limits. When this happens, action must be taken to remove workers from areas of high concentration. Operators and work area supervisors should take precautions to insure adequate ventilation of the workspace at all times. Carbon monoxide detection monitors should be used to determine that adequate ventilation exists.



### WARNING HEARING HAZARD

DURING NORMAL USE OF THIS MACHINE, OPERATOR MAY BE EXPOSED TO A NOISE LEVEL EQUAL TO **85 dB (A)** OR GREATER. TEMPORARY AND/OR PERMANENT DAMAGE TO HEARING MAY RESULT. HEARING PROTECTION REQUIRED.

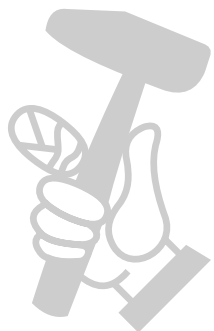

МАГАЗИН  
**БАШ МАЙСТОРА**<sup>®</sup>  
ПРОФЕСИОНАЛНИ РЕШЕНИЯ

---

# SAFETY INSTRUCTIONS

---

## SAFETY FIRST!



### WARNINGS

#### DO's AND DO NOT's



**WARNING: FAILURE TO COMPLY WITH THESE WARNINGS AND OPERATING INSTRUCTIONS COULD RESULT IN DEATH OR SERIOUS BODILY INJURY.** 

#### DO

- DO Read this entire operator's manual before operating this machine. Read and understand all warnings, instructions, controls, and symbol definitions contained in this manual, and on the machine.
- DO always give a copy of this manual to the equipment user. If you need extra copies, call TOLL FREE 1-800-288-5040 in USA, or +1-913-928-1300 for International, or see "contact information" section of this manual.
- DO keep all guards in place and in good condition.
- DO wear safety approved hearing, eye, head and respiratory protection.
- DO read and understand all warnings and instructions on the machine.
- DO keep all parts of your body away from the blade and all other moving parts.
- DO know how to stop the machine quickly in case of emergency.
- DO shut off the engine and allow it to cool before refueling or doing maintenance.
- DO inspect the blade, flanges and shafts for damage before installing the blade.
- DO use the blade flange size shown for each blade size.
- DO use only steel center diamond blades manufactured for use on concrete saws.
- DO use only the blade flanges supplied with the saw. Never use damaged or worn blade flanges.
- DO use only blades marked with a maximum operating speed greater than the blade shaft speed. Verify speed by checking blade shaft rpm and pulley diameters and blade flange diameters.
- DO verify saw drive configuration by checking blade shaft RPM, pulley diameters, and blade flange diameter.
- DO read all safety materials and instructions that accompany any blade used with this machine.
- DO inspect each blade carefully before using it. If there are any signs of damage or unusual wear, **DO NOT USE THE BLADE.**
- DO mount the blade solidly and firmly, Wrench tighten the arbor nut.
- DO make sure the blade and flanges are clean and free of dirt and debris before mounting the blade on the saw.
- DO use the correct blade for the type of work being done. Check with blade manufacturer if you do not know if blade is correct.
- DO use caution and follow the instructions when loading and unloading the machine.
- DO operate this machine only in well ventilated areas. Breathing Poison Exhaust Gas could result in death.
- DO instruct bystanders on where to stand while the machine is in operation.
- DO establish a training program for all operators of this machine.
- DO clear the work area of unnecessary people. Never allow anyone to stand in front of or behind the blade while the engine is running.
- DO make sure the blade is not contacting anything before starting the engine.
- DO use caution when lifting and transporting this machine.
- DO always tie down the machine when transporting.
- DO use caution and follow instructions when setting up or transporting the machine.
- DO have all service performed by competent service personnel
- DO verify the blade arbor hole matches the machine spindle before mounting the blade.
- DO always check for buried hazards, such as electrical or gas lines before sawing. Always contact local utilities before operation in unknown areas.
- DO move the machine at least 10 feet (3 meters) from the fueling point before starting the engine and make sure the fuel cap is on the machine and properly tightened.
- DO lift machine only from specified lifting point.
- DO clean the machine after each day's use.
- DO use the proper blade flange size for each blade size. Never use damaged or worn blade flanges.
- DO use caution when handling fuel.
- DO only cut in a straight line, and only saw as deep as the job specifications require.

---

# SAFETY INSTRUCTIONS

---

## SAFETY FIRST!



### WARNINGS DO's AND DO NOT's



**WARNING: FAILURE TO COMPLY WITH THESE WARNINGS AND OPERATING INSTRUCTIONS COULD RESULT IN DEATH OR SERIOUS BODILY INJURY.**

#### DO NOT

- DO NOT** operate this machine unless you have read and understood this operator's manual.
- DO NOT** operate this machine without the blade guard, or other protective guards in place.
- DO NOT** stand behind or in front of the blade path while the engine is running.
- DO NOT** leave this machine unattended while the engine is running.
- DO NOT** work on this machine while the engine is running.
- DO NOT** operate this machine when you are tired, fatigued or under the influence of drugs or alcohol.
- DO NOT** use a wet blade without adequate water supply to the blade.
- DO NOT** exceed maximum blade speed shown for each blade size. Excessive speed could result in blade breakage.
- DO NOT** operate the machine if you are uncertain of how to run the machine.
- DO NOT** use damaged equipment or blades.
- DO NOT** touch or try to stop a moving blade with your hand.
- DO NOT** cock, jam, wedge or twist the blade in a cut.
- DO NOT** transport a cutting machine with the blade mounted on the machine.
- DO NOT** use a blade that has been dropped or damaged.
- DO NOT** use carbide tipped blades.
- DO NOT** touch a dry cutting diamond blade immediately after use. These blades require several minutes to cool after each cut.
- DO NOT** use damaged or worn blade flanges.
- DO NOT** allow other persons to be near the machine when starting, refueling, or when the machine is in operation.
- DO NOT** operate this machine in an enclosed area. Breathing Poison Exhaust Gas could result in death.
- DO NOT** operate this machine in the vicinity of anything that is flammable. Sparks could cause a fire or an explosion.
- DO NOT** allow blade exposure from the guard to be more than 180 degrees.
- DO NOT** operate this machine with the belt guards or blade guard removed.
- DO NOT** operate this machine unless you are specifically trained for its operation.
- DO NOT** use a blade that has been over heated (Core has a bluish color).
- DO NOT** jam material into the blade.
- DO NOT** grind on the side of the blade.
- DO NOT** tow this machine behind a vehicle.
- DO NOT** operate this machine with the any guards or shields removed.
- DO NOT** cut deeper than 1" per pass with a dry blade. Step cut to achieve deeper cuts.
- DO NOT** operate this machine while under the influence of drugs or alcohol.

\*\*\*\*\*

**This saw was designed for certain applications only. DO NOT modify this saw or use for any application other than for which it was designed. If you have any questions relative to its application, DO NOT use the saw until you have written Husqvarna Construction Products and we have advised you.**

Husqvarna Construction Products North America  
17400 West 119th Street, Olathe, Kansas 66061 USA

## PARTS IDENTIFICATION (WHAT IS WHAT)

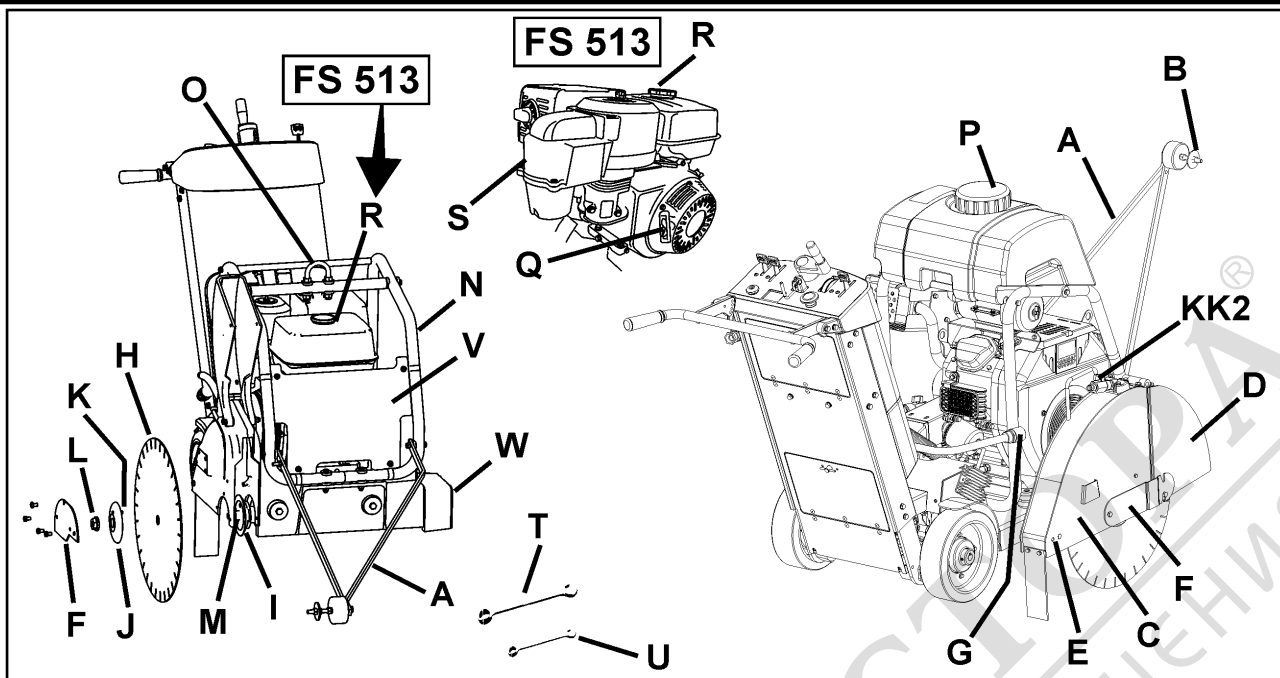

**A. Front Pointer:** Use to Guide machine in a straight line.

**B. Guide Wheel:** On Front Pointer (A). Align to cutting line and Blade (H) to produce straight cuts.

**C. Blade Guard:** Covers Blade (H). Must always be in place when operating machine! Note tool direction as marked on guard with an arrow.

**D. Blade Guard Front:** Part of Blade Guard. Can be raised to install Blade (H).

**E. Blade Guard Rear Bolt:** Holds Blade Guard (C) in position. Must be removed and relocated if Blade Guard (C) is moved.

**F. Blade Guard Latch Plate:** Covers Outer Flange (J).

**G. Water Hose Disconnect (G):** Connects Blade Guard (C) to Water Control Valve (KK1, KK2) or Water Tank (P). Can be used when Blade Guard (C) is mounted to left or right side of machine

**H. Blade:** Tool that cuts asphalt or concrete material – not included with machine.

**I. Inner Flange:** Arbor on which the Blade (H) is mounted. Replace if Damaged or worn.

**J. Outer Flange:** Used to hold Blade (H) in position. Contains Locking Pin (K) that must go through Blade (H). Replace if damaged or worn.

**K. Locking Pin:** Holds Blade (H) in position. Replace if Damaged or worn.

**L. Blade Shaft Nut (L1 / L2):** Holds Outer Flange (J) to machine. Nut (L1) on right side of machine has Left Hand threads. Nut (L2) (not shown) on left side of machine has Right Hand threads.

**M. Blade Arbor:** Blade (H) mounts on this surface.

**N. Water Tank / Lifting Point Support:** Holds Water Tank (P). Supports Lifting Point (O).

**O. Lifting Point:** Lift machine only from this point!

**P. Water Tank (If Equipped):** 25 Liter (6.6 U.S. Gallon) water capacity. Fill only with water! Do not fill with gasoline or other flammable substances! Use only for dust suppression when cutting dry. Use only with laser welded (dry) Diamond Blades (H).

**Q. Engine Starting Rope (FS 513 Only):** Use to start engine. See engine operation manual.

**R. Fuel Tank:** Fuel fill point.

**FS 520 / FS 524:** Located at rear of machine. Fuel fill is located on Left hand side of fuel tank.

**FS 513:** Located on engine - See engine operation manual.

**S. Engine Air Cleaner (FS 513 Shown):** Check daily. Clean every four (4) hours if cutting in dusty conditions. See engine operation manual and maintenance section of this document.

**T. Blade Shaft Wrench (27mm):** Use for installing and removing Blade (H). Store in Tool Compartment (BB).

**U. Wrench (13mm):** Use for many maintenance items on machine. Store in Tool Compartment (BB).

**V. Front Cover:** Clips to Water Tank Support (N). Open to turn Engine Start Switch (DD) ON (1) or OFF (0) [FS 513 Only].

**W. Shaft Guard:** Protects Inner Flange (I). Always installed on opposite side of frame to Blade Guard (C).

**X. Depth Control Grease Fitting:** Not Shown. See Maintenance section of this document.

**Y. Blade Guard Mounting Spade:** Holds Blade Guard (C) in position.

**Z. Engine Oil Dipstick:** Use to check engine oil level (Not Shown – See Operation Section of this document).

## PARTS IDENTIFICATION (WHAT IS WHAT)

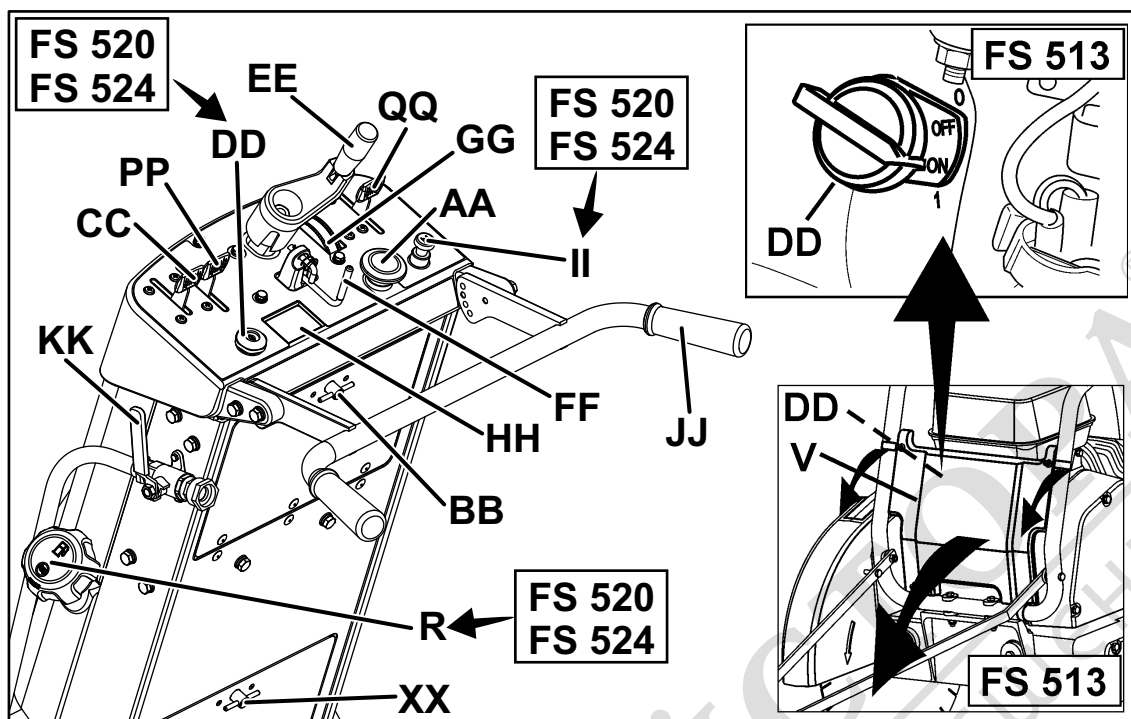

**AA. Emergency Stop Switch:** Depress Switch to STOP engine in emergencies. Reset by pulling outward (pull up) to allow re-starting of machine.

**BB. Tool Compartment:** Contains Operation Manual, Parts List, & two wrenches (T & U) (13mm & 27mm). Open by turning knob 180 degrees. Always return Operation Manual to this area for future reference.

**CC. Engine Throttle:** Controls Engine speed (RPM). Push forward to increase engine speed. Pull backwards to decrease engine speed. All sawing is done at maximum engine speed.

**DD. Engine Start Switch:**

**FS 513:** Located on engine, behind Front Cover (V). Must be ON (1) to start engine. Use to turn engine OFF ("0") in non-emergency situations.

**FS 520 & FS 524 (Electric Start):** A key switch located on lower left side of console. Turn key clockwise to start engine.

**EE. Blade Depth Control:** Turn Counter-Clockwise to raise Diamond Blade (H) and Clockwise to lower Diamond Blade (H).

**FF. Blade Depth Stop:** To Lock Blade Depth Control (EE) in position. Pull Blade Depth Stop toward rear of machine and turn 90 degrees to lock in open position.

**GG. Blade Depth Indicator:** Shows cutting depth of Diamond Blade (H) in centimeters (orange color) and inches (white color). Operation: With engine OFF ("0"), lower Diamond Blade (H) until in contacts the cutting surface. Rotate Blade Depth Indicator to align "0" with arrows. Raise Saw. When saw is lowered into cut, current cutting depth is shown.

**HH. Engine Tachometer (RPM):** Shows engine speed in revolutions per minute if engine is running. Shows total operation time when engine is OFF ("0"). Total operation time shown in minutes from 0-59 minutes, and hours for 60+ minutes.

**II. Engine Choke Knob:** If the engine is cold, use the choke. Pull the knob up to engage the choke. Push down to disengage after engine starts. Please see the engine Operator's Manual for more information.

**JJ. Rear Handle:** Operator position is behind machine with both hands on Rear Handle. Handle is adjustable to several positions.

**KK1. Water Control Valve:** Controls water flow to blade. Located on Left side of machine, near Rear Handle (JJ). Not used with the water tank (if equipped).

**KK2. Blade Guard Water Control Valve:** Controls the water flow to the blade. Located on blade guard. Used with water tank (if equipped).

**LL. Belt Guard (Not Shown):** Covers engine drive belt.

**MM. Belt Drive Idler:** Used to hold tension on Blade Shaft Drive Belt.

**NN. Oil Drain Hose:** Use to remove oil from engine.

**OO. Parking Brake (EU units):** Used to hold machine in parked position. With engine OFF (0), apply the brake by moving Transmission Engagement Lever (PP), to the "Engaged" position. Move lever to dis-engaged position before starting engine!

**PP. Transmission Engagement Lever:** MUST BE in rear (dis-engaged) position to start engine for FS 520 and FS 524 (Neutral Start function). Push forward to engage transmission. Push rearward to dis-engage transmission. With transmission dis-engaged, machine can be moved with engine turned OFF (0). See "OO. Parking Brake" for additional information.

## PARTS IDENTIFICATION (WHAT IS WHAT)

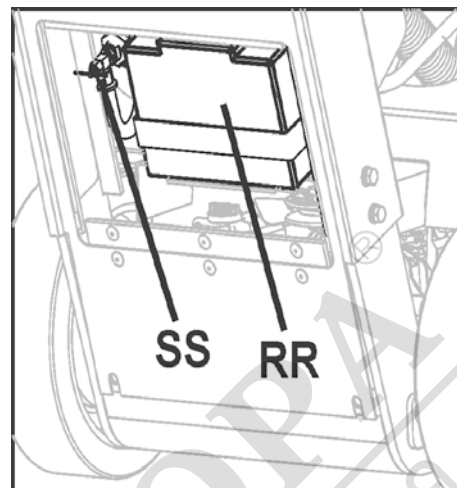
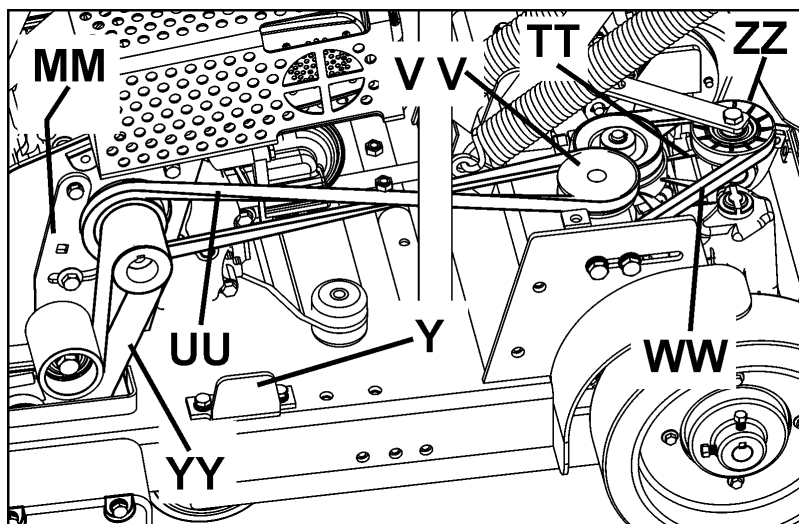

**QQ. Travel Speed Lever:** Controls ground travel speed and direction of machine (forward or reverse). Move lever forward to travel forward. Move lever rearward to travel backward. Lever **MUST** be near "STOP" position before moving Transmission Engagement Lever (PP) into "Engaged" position.

**RR. Starting Battery (FS 520, FS 524 Only):** Located behind lower access panel at the rear of machine. See "Battery Maintenance" section of this document for instructions on charging and maintenance.

**SS. Fuel Shut-Off Valve:** Used to shut off fuel supply to engine.

**FS 520 / FS 524:** Located behind lower access door at rear of machine. Turn counter-clockwise to close.

**FS 513:** Located on engine (see engine operation manual for more information).

**TT. Hydrostatic Transmission:** Controls travel speed and direction of machine. Maintenance free for the life of the machine.

**UU. Transmission Drive Tensioner Belt:** Connects Engine to Transmission Drive Belt Tensioner (VV). Check periodically for wear on belt and sheaves.

**V V. Transmission Drive Tensioner:** Used to tension Transmission Drive Belt (UU). See maintenance section of this document for more information.

**WW. Hydrostatic Transmission Belt:** Drives Hydrostatic Transmission (TT). Connects Transmission Drive Belt Tensioner (VV) to Hydrostatic Transmission (TT). See maintenance section of this document for more information.

**XX. Lower Access Panel:** Open panel to expose Starting Battery (RR) and Fuel Shut-Off Valve (SS).

**YY. Bladeshaft Drive Belt:** Connects Engine and Blade-shaft. See maintenance section of this document for more information.

**ZZ. Hydrostatic Transmission Belt Tensioner:** Spring loaded idler used to tension Hydrostatic Transmission Belt (WW). See maintenance section of this document for more information.

AAA. --

BBB. --

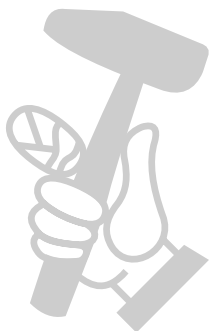



# ASSEMBLY

Assemble the following items before operating machine for the first time.

**Re-Position Rear Handle (JJ):** Rear Handle (JJ) is shipped in storage position shown. It must be repositioned to use the machine.

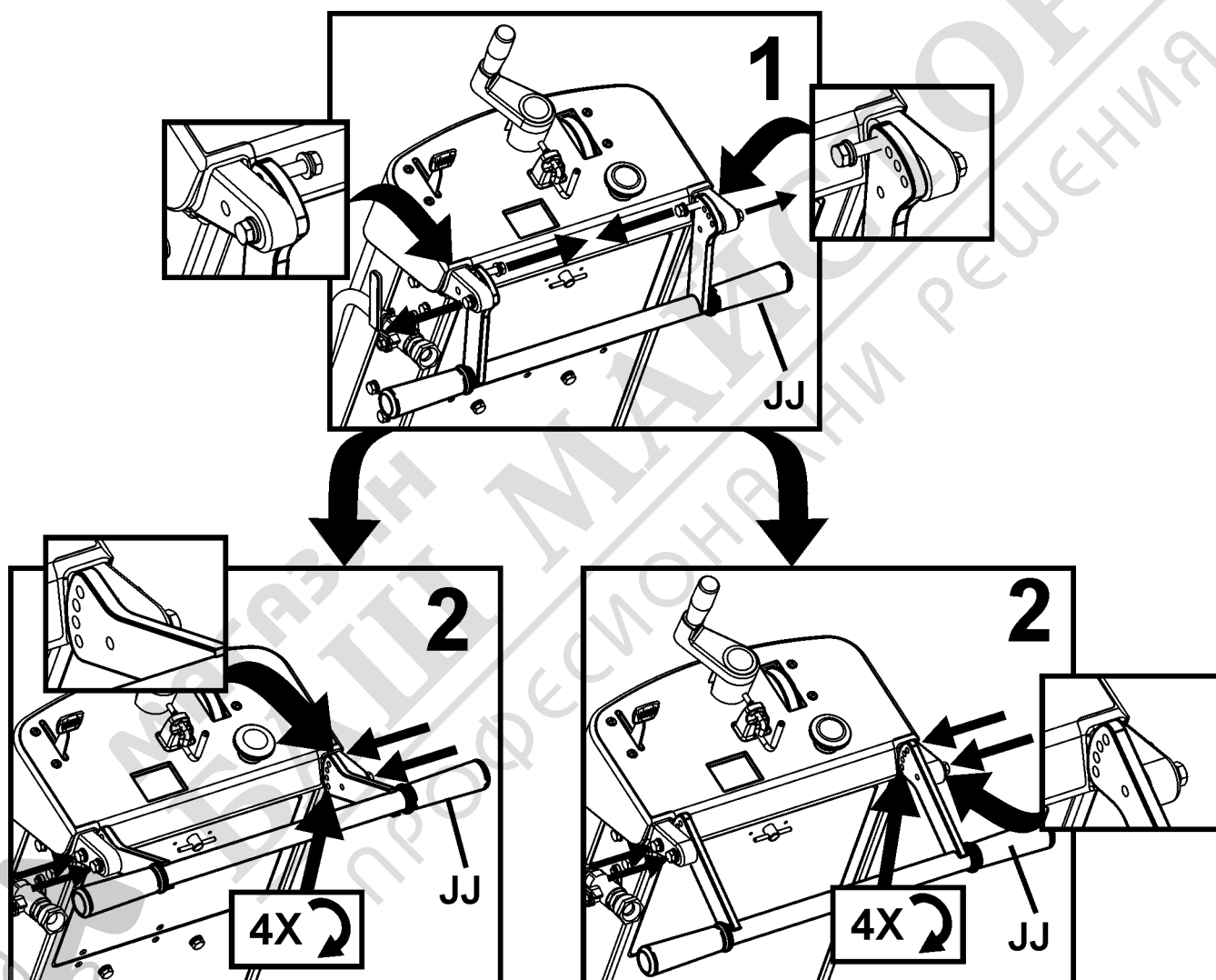

# ASSEMBLY

## Install Front Pointer (A):

1. Using screws, washers and nuts installed in the Front Pointer (A), install onto tube frame of Water Tank Support (N). Adjust locking nuts to allow Pointer (A) to pivot freely.
2. Route pointer rope to avoid hot surfaces. Two loops in rope allow attachment to Rear Handle (JJ).

**Note:** “*Single Pointer*” (A) shown. Some regions have “*Dual Pointer*” as standard equipment. For all regions, Dual Pointer is available as an accessory. See “accessories” section of this document, or spare parts list for more information.

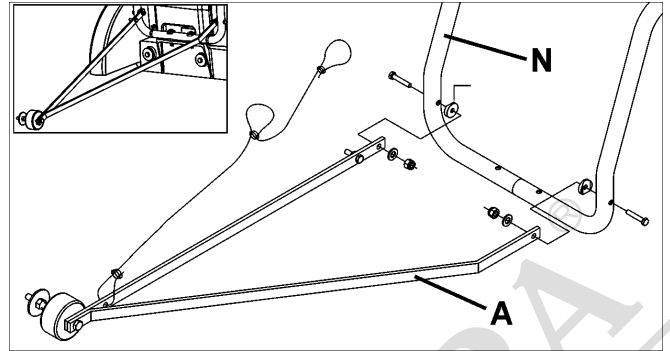

## Blade Guard Front (D):

1. Using 13mm Wrench (U) provided, remove two (2) M8 screws located in front of and below Blade Guard Latch Plate (F), and the M8 screw in Blade Guard Front (D) [as indicated by arrows]. Loosen, but do not remove, remaining screw Blade Guard Latch Plate (F). Rotate Blade Guard Latch Plate (F), and Blade Guard Front (D) downward.

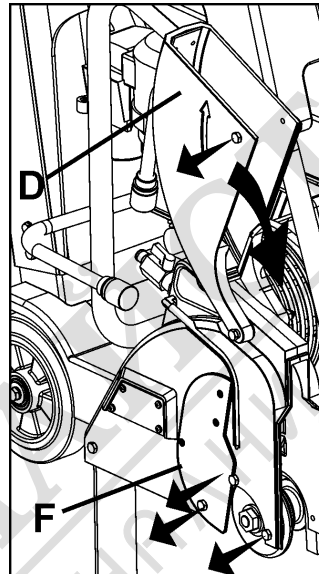

### **! WARNING!**

Blade Guard Latch Plate (F) Must Be Installed before operation. Failure to install before operating machine could create a Hazardous situation!

Always keep all guards in place when operating machine!

2. Reinstall three (3) M8 screws in Blade Guard Latch Plate (F) as shown in the diagram at the right. Use the 13mm Wrench (U) (supplied) to securely tighten the four (4) M8 bolts that hold the Blade Guard Latch Plate (F) in position.

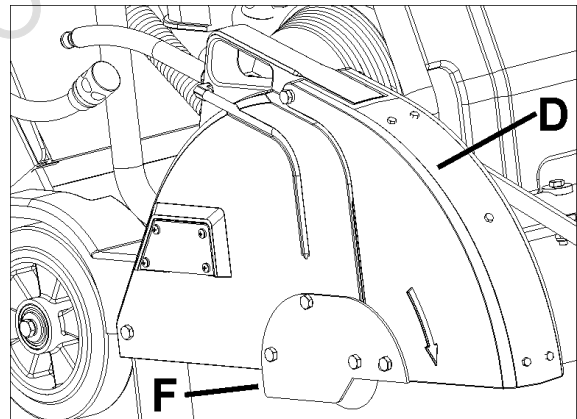

## Re-Position Blade Depth Control Handle (EE):

Pull outward on Blade Depth Control Handle (EE) and rotate 90 degrees until it snaps in position shown.

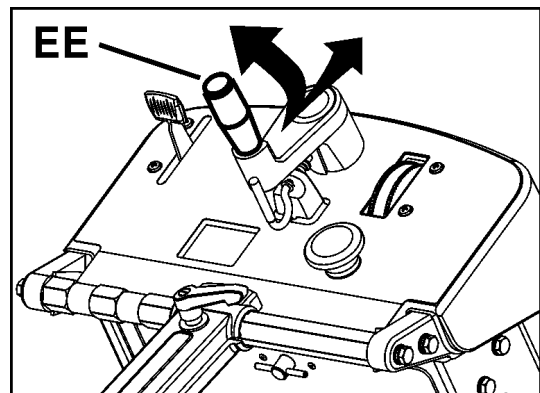

# ASSEMBLY

## Install Water Tank (P) (if equipped):

- A factory installed water tank is available in some regions. An optional water tank kit is available for all regions.
- If water tank was previously installed on machine, read these instructions to verify that installation is correct. Follow all WARNINGS for installation and use of the Water Tank.
- Verify the contents of the Water Tank Kit See Diagram at right.

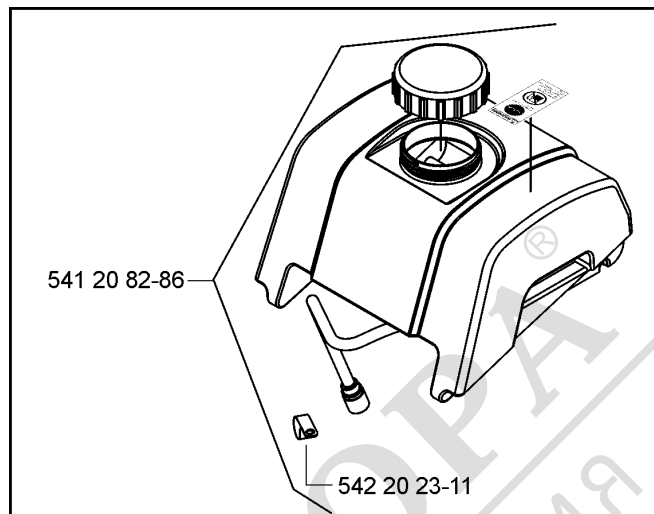

1. **FS 513 Only:** Temporarily remove the right hand (same side of machine as engine starter rope) NUT from Lifting Eye (O). See diagram at right.

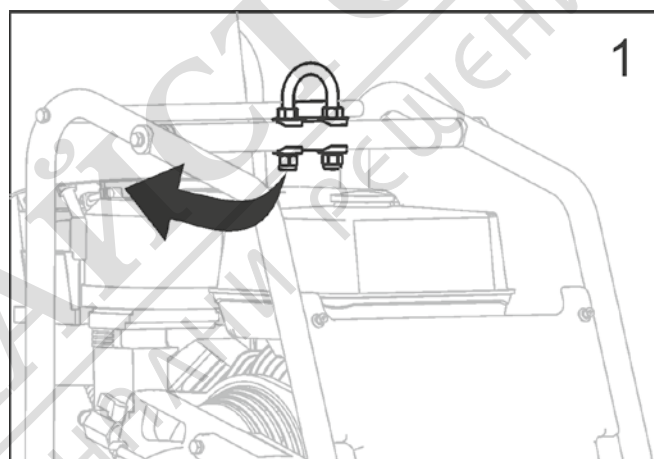

2. **FS 513 Only:** Install CLAMP supplied in Water Tank Kit (P), and then reinstall the NUT. See diagram at right.

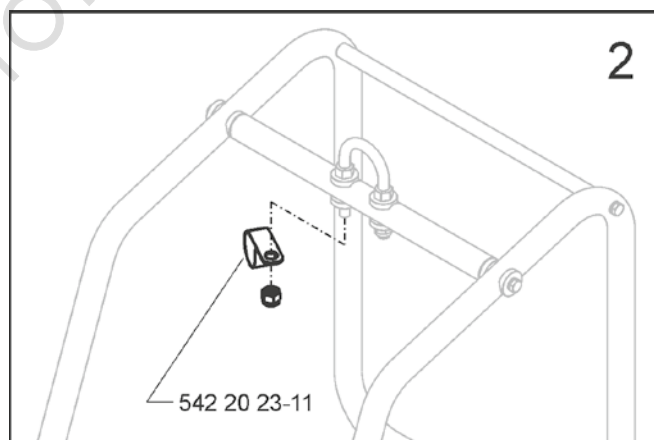

3. **FS 513 Only:** Torque as specified below, and diagram at right.

<b>NOTICE</b>
<b>Torque Lifting Eye NUT to 83 N-m (61 lb-ft) minimum.</b>

<b>⚠ WARNING!</b>
Torque NUT as specified, else failure of LIFTING EYE (O) could occur. Injury or death could occur if LIFTING EYE fails while lifting machine.

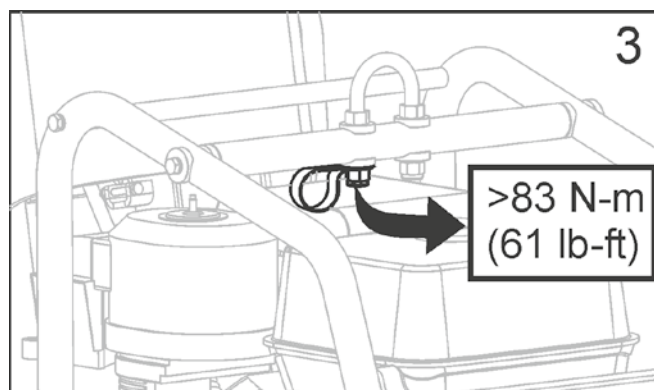

## ASSEMBLY

4. Position Water Tank, and route Water Tank Hose as shown in Diagram at right (**FS 513**). FS 520 / FS 524 do not use clamp shown in diagram.

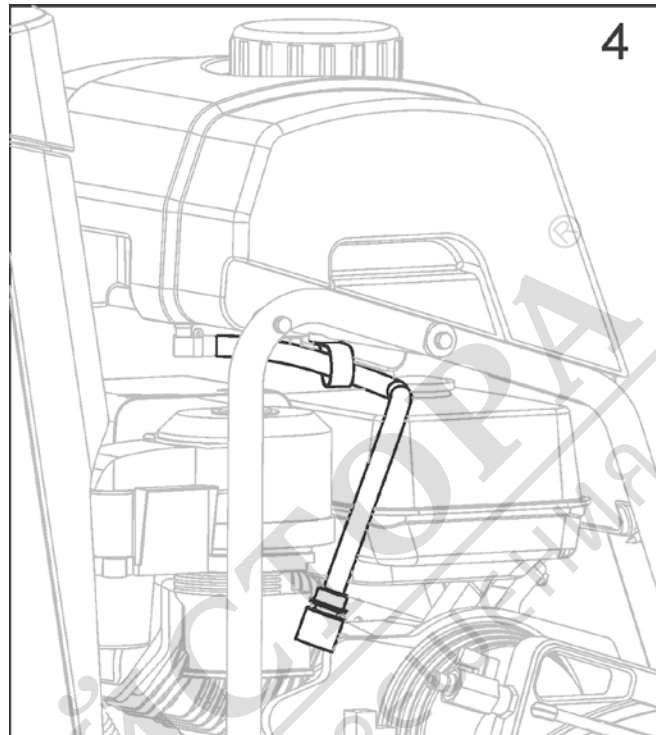

5. Align rear bar and recessed area at rear of water tank.

- Press down firmly on water tank so it snaps in position onto rear bar.
- When properly installed, water tank should pivot freely on rear bar.

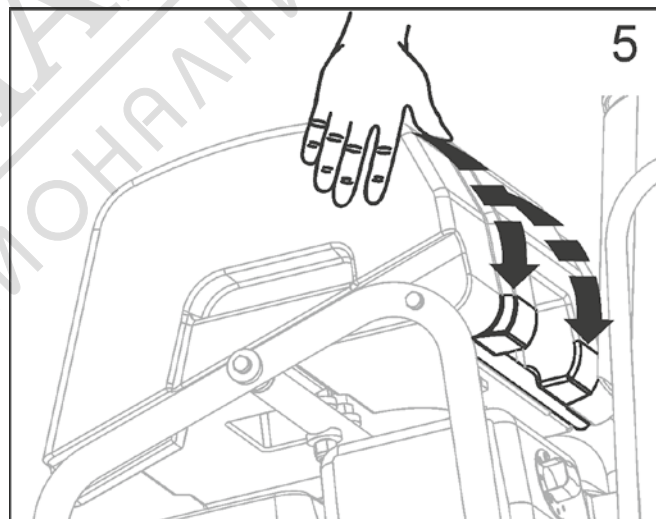

6. Disconnect existing water hose from blade guard. This is the water hose from water control valve mounted on saw.

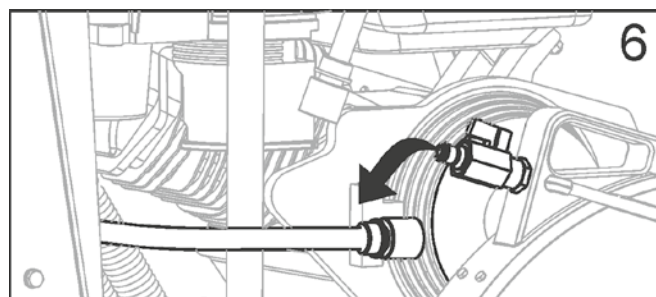

## ASSEMBLY

7. Connect Water tank hose to blade guard water valve.

- Verify that blade guard water valve is in the OFF position.
- The water tank hose is now assembled to the saw.

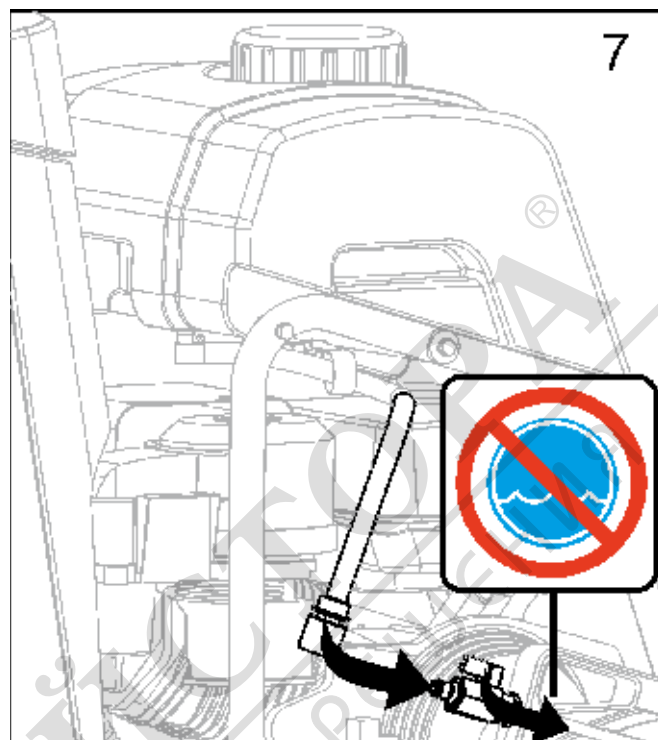

### Filling Water Tank:

8. Remove the cap by turning counter clockwise. See diagram at right.

- Fill water tank only with water. Read all WARNINGS before using water tank.
- Re-install the cap by turning clockwise.
- Water tank is designed only to suppress airborne concrete dust, and should only be used with “dry” cutting diamond blades.

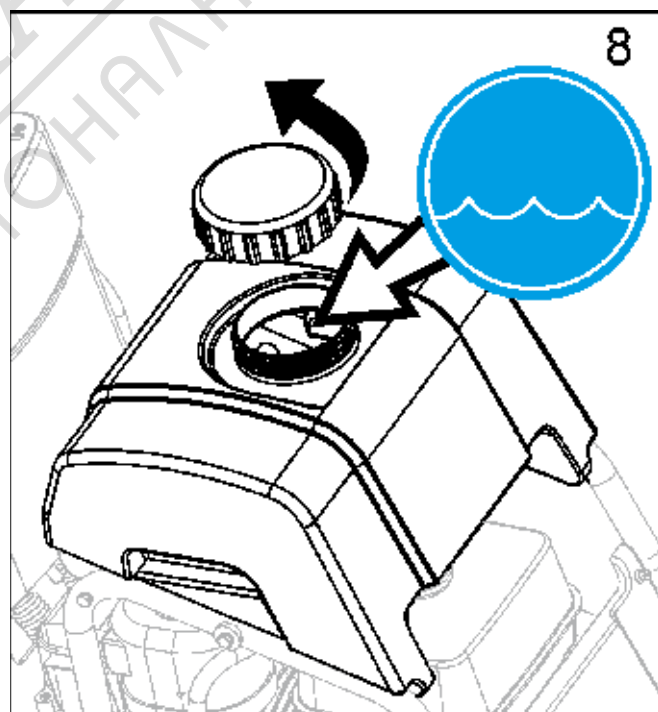

### WARNING!

DO NOT use conventional (wet) diamond blades with water tank as water source. Water flow is not sufficient to properly cool blade!

Fill Water Tank Only With Water!

Never fill Water Tank (P) with flammable liquids or gasoline, else injury or death could occur!

# OPERATION

## Before Operation:

**Use:** This machine is used only for wet or dry sawing of old and new concrete and asphalt.

### **! WARNING!**

DO NOT use for dry cutting in European Union (EU) regions. Machine is not equipped with a dust port.

**Tools:** Use machine only with the following tools (H): Water Cooled Diamond Blades. Reinforced Abrasive Blades or Dry Cutting Diamond blades should NOT be used within European Union (EU) regions because this machine, as supplied, does not include a dust collector port.

Diameter: 300 mm (12") – 500 mm (20").

Bore: 25.4mm (1.00").

### **! WARNING!**

DO NOT use carbide, wood saw, or circular saw blades on this machine, else injury or death could occur.

## Re-Locating the Blade Guard (C) - If Required:

Blade Guard (C) is factory installed on right hand side of machine, but can be relocated to left side. This may allow cutting closer to obstacles, if approaching them from the opposite direction is not possible.

1. Use 13mm Wrench (U) to remove Blade Guard Rear Bolt (E) from Blade Guard (C).
2. Push back collar to separate Water Hose Disconnect (G). Male half remains with Blade Guard (C). Female half remains with Water Tank (P) or Water Control Valve (KK).
3. Lift Blade Guard (C) upward, and off of Blade Guard Mounting Spade (Y).
4. Use 13mm Wrench (U) to remove four (4) screws that attach Blade Guard Latch Plate (F). Re-attach the Blade Guard Latch Plate (F) to the left hand side of Blade Guard (C).
5. Remove and relocate Shaft Guard (W) from left hand side of machine to right hand side.
6. Lower Blade Guard (C) onto Blade Guard Mounting Spade (Y) on left hand side of machine.
7. Re-Install Rear Bolt (E) in Blade Guard (C).
8. Re-Attach Water Hose Disconnect (G) from Blade Guard (C) to Water Tank (P) or Water Valve (KK). Take care that relocated hose will not contact muffler.
9. Relocate and realign Front Pointer (A) so Guide Wheel (B) is on left side of machine.

### **! WARNING!**



Before operating machine, read and understand this entire operation manual & engine operation manual supplied with engine.



Be familiar with machine before operation!

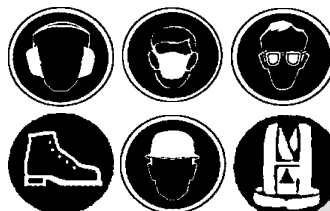

Operator must wear personal protective equipment & clothing appropriate to the work he is doing. Personal protective equipment, such as hearing & eye protection, is mandatory.

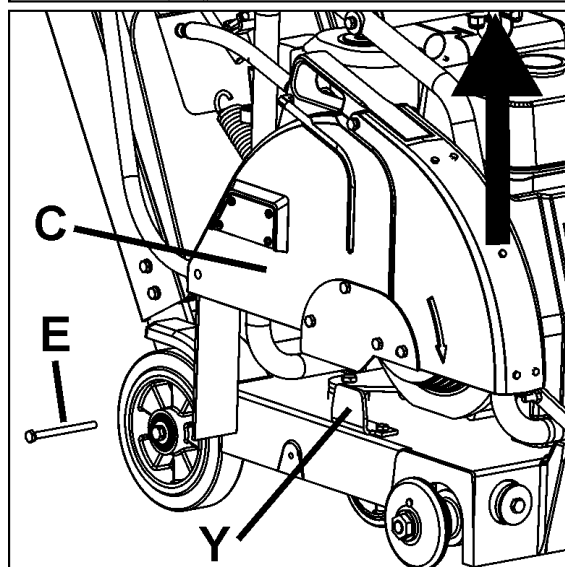
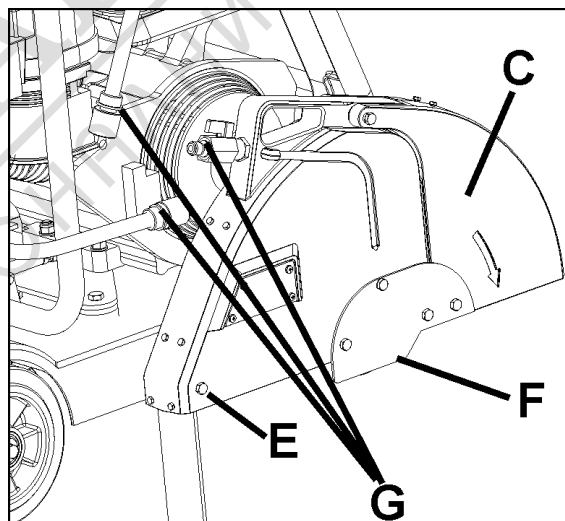

# OPERATION

## Transporting & Lifting Machine:

- Lift machine only from Lifting Point (O).
- Always remove Blade (H) before lifting, loading, or transporting.
- Use a proper lifting strap rated for at least the maximum mass of the machine. The nominal and maximum mass of the machine are shown in the TECHNICAL DATA section of this document.

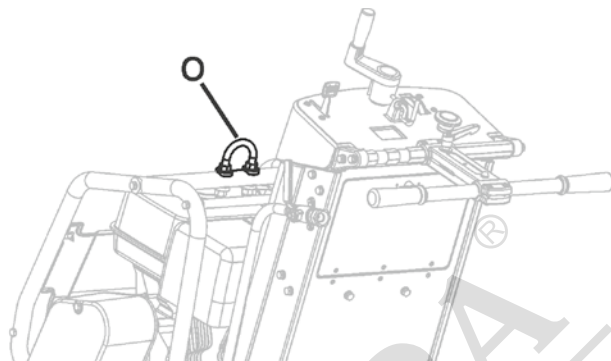

Remove Blade (H) before lifting, loading, or transporting machine.

## Lifting machine equipped with Water Tank:

- Before lifting a machine equipped with a water tank:
  1. Empty water from tank.
  2. Remove Blade.
  3. Lower machine until frame is parallel to ground.
  4. Pivot front of water tank upward until it rests against aluminum cowl top. Do not rest water tank cap against plastic cowl front - damage during lifting could occur.
  5. Attach proper lifting strap to Lifting Point (O).
  6. Test Lift machine at a low level (just a few centimeters) to verify tank remains secured to machine, and will not be damaged or cause damage.
  7. If water tank equipped machine can not be lifted without damage to the machine or tank, remove water tank before lifting.

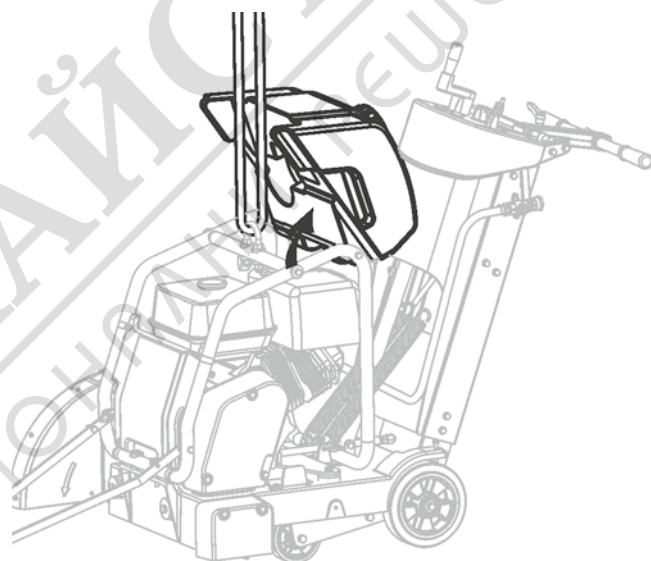

### NOTICE

Water tank or saw could be damaged if saw is not lifted properly. Closely monitor for damage while lifting machine.

## Parking Machine:

- Machines used in some regions may require a Parking Brake. Parking Brake for this machine is applied using Transmission Engagement Lever (PP).
- Parking brake is designed to hold machine in position on a slope of 10 degrees or less, with rear of machine on downhill side of slope (maximum weight on braked wheel).



**Parking Brake - Engage (See Diagram):**

1. Turn engine OFF (O).
2. Move Transmission Engagement Lever (PP) forward to "engaged" position.

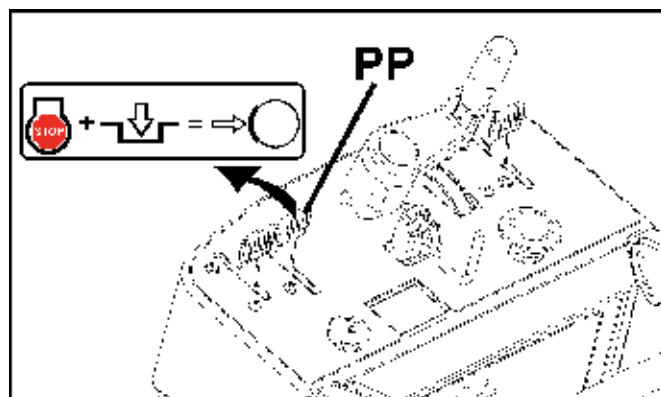

# OPERATION

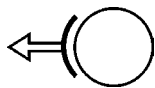

**Parking Brake - Dis-engage (See Diagram):**

1. Move Transmission Engagement Lever (PP) rearward to “dis-engaged” position. Must be fully dis-engaged.
2. Engine may now be started.

## NOTICE

Parking Brake must be dis-engaged to start engine (FS 520 & FS 524). Move Transmission Engagement Lever (PP) rearward to Dis-Engaged position.

## Gasoline Engine Models:

Refer to the engine operating manual for proper engine operation.

**FUEL:** Unleaded gasoline is recommended. See engine operation manual for more information.

**OIL:** Check that engine oil level is correct using the Engine Oil Dipstick (Z). See Maintenance section of this document or engine operation manual for more information.

Because the engine often operates at an angle, check oil level with engine horizontal. Check frequently to ensure that oil level never falls below lower mark on dipstick. 10W30 oil is recommended. See engine operation manual for more information.

## NOTICE

If engine is equipped with a low oil shutdown system, engine will not start if oil level is low. Also, engine may stop if maximum angle of operation is exceeded. See engine operation manual.

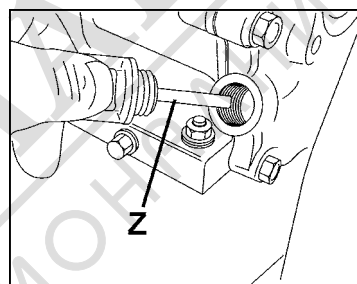
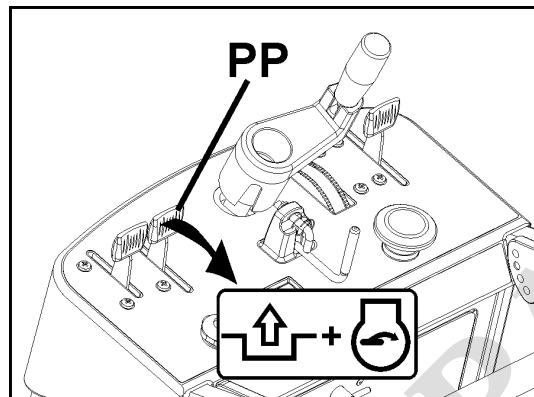

FS 513

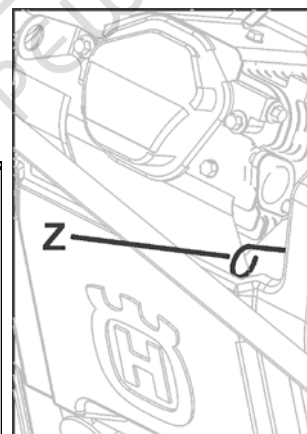

FS 520, FS 524

## All Models:

Front Pointer (A) must be checked for alignment with blade. Lay a straight edge along Inner Flange (I). Align Front Pointer (A) to straight edge. If required, adjust Front Pointer (A) by loosening nuts that hold Guide Wheel (B) in place. Align Guide Wheel (B) to straight edge and re-tighten nuts.

Check that water tubing in the Blade Guard (C) is open and that each side of blade has an adequate supply of water.

Test the water supply for pressure and quantity (flow) before starting the saw.

Saw only as deep as the job specifications require. Sawing deeper than required will add excessive wear the blade and machine.

Cut in increments of 50mm (2 inches) deep until cutting depth specification is reached. This is known as “step cutting”.

Saw only in a straight line. Mark cutting line clearly so saw operator can follow line without difficulty. Saw should NOT be twisted from side to side to force blade back on line.

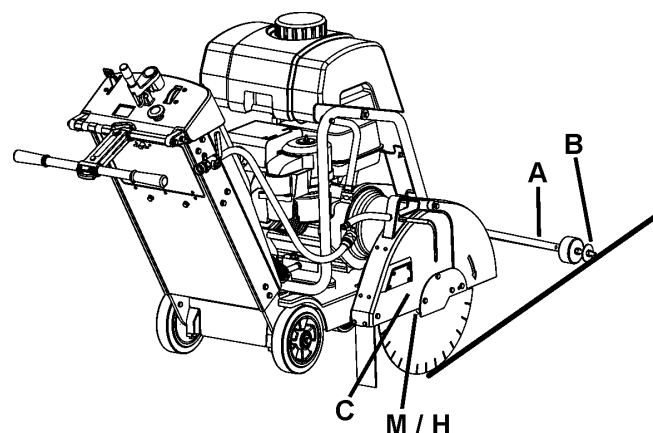



# OPERATION

## Fitting the Diamond Blade (H):



Install Diamond Blade (H) at job site. Do not transport the machine with the Diamond Blade (H) installed.

1. Open Front Cover (V).
2. Set Engine Start Switch (DD) to OFF ("0") position.
3. Raise Diamond Blade (H) to highest position by turning Blade Depth Control (EE) Counter-Clockwise.
4. Use 13mm Wrench (U) located in Tool Compartment (BB), to loosen and remove four (4) M8 bolts that attach Blade Guard Latch Plate (F). Temporarily remove Blade Guard Latch Plate (F).
5. Raise Blade Guard Front (D).
6. Using the 27mm Blade Shaft Wrench (T), loosen and remove the Blade Shaft Nut (L) that secures the Outer Flange (J) in position.

### NOTICE

Blade Shaft Nut (L1) on right hand side of machine has left hand threads. To loosen, turn clockwise.

Blade Shaft Nut (L2)(not shown) on left hand side of machine has right hand threads. To loosen, turn counter-clockwise.

7. Remove Outer Flange (J).
8. Check that Blade Shaft Arbor (M), Inner Flange (I), and Outer Flange (J) are clean and free of foreign objects.
9. Fit Diamond Blade (H) onto Blade Shaft Arbor (M). Direction of rotation is shown by arrows on Diamond Blade (H) and Blade Guard Front (D). See diagram at right.
10. Install Outer Flange (J) onto Blade Shaft Arbor (M). Make sure that Locking Pin (K) passes through Diamond Blade (H) and into Inner Flange (I).
11. Rotate Outer Flange (J) and Diamond Blade (H) in opposite direction of blade rotation to remove backlash.
12. Install Blade Shaft Nut (L). Tighten using 27mm Blade Shaft Wrench (T).

### NOTICE

Blade Shaft Nut (L1) on right hand side of machine has left hand threads. To tighten, turn counter-clockwise. Torque to 45 N•m (33 lb-ft) - minimum.

Blade Shaft Nut (L2)(not shown) on left hand side of machine has right hand threads. To tighten, turn clockwise. Torque to 45 N•m (33 lb-ft) - minimum.

13. Lower Blade Guard Front (D).
14. Re-install and tighten Blade Guard Latch Plate (F).

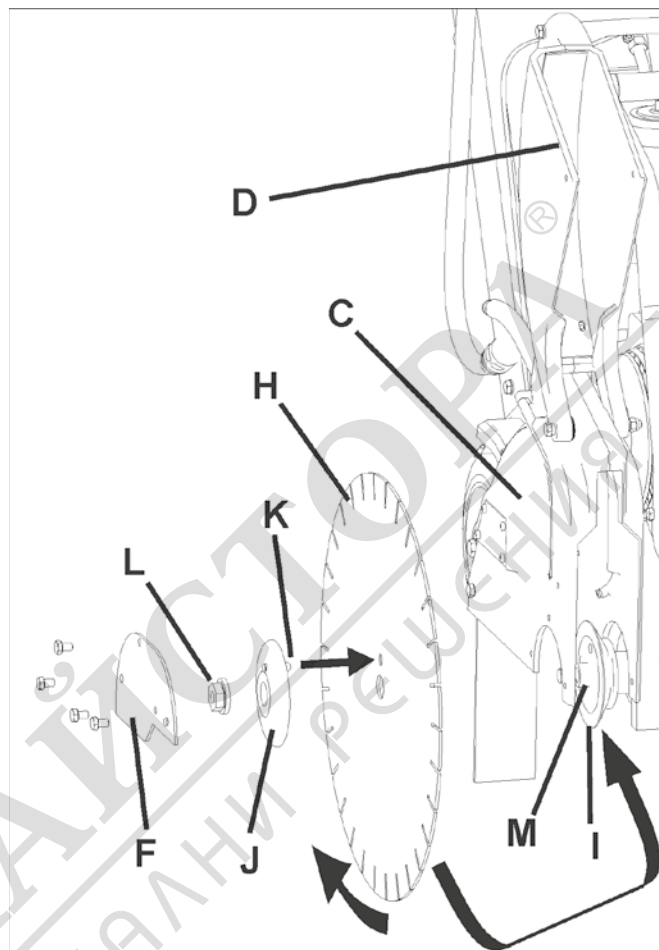

### WARNING!

USE ONLY Blades (H) marked with a maximum operating speed greater than blade shaft speed of machine.

DO NOT change to a larger size blade without changing to proper belts and pulleys!

DO NOT operate machine without proper guard over Diamond Blade (H)!

DO NOT operate machine with Front Blade Guard (D) raised!

Blade (H) exposure MUST NOT exceed 180 degrees when operating machine!

Contact Surfaces of Blade Shaft Arbor (M), Inner Flange (I), and Outer Flange (J) MUST BE clean and free of foreign objects.

DO NOT transport machine with Blade (H) installed.

DO NOT use conventional (wet) Diamond Blades (H) without water.

READ operation instructions supplied with Blade (H).

DO NOT install Blade (H) unless power source is in OFF (0) position, and dis-connected from power supply.

# OPERATION

## Starting and cutting with machine:

- Using Blade Depth Control (EE), raise Diamond Blade (H) as high as possible so it will not strike pavement when maneuvering. Pull out on Blade Depth Stop (FF) if required.
- Dis-engage Parking Brake (OO) by moving Transmission Engagement Lever (PP) rearward to Dis-Engaged position.
- With engine OFF, maneuver machine into position near line to be cut.
- Lower Front Pointer (A) onto cutting surface.
- Set Depth Indicator (GG) (use if desired):
  - 1) Lower machine until diamond blade contacts cutting surface.
  - 2) Set Depth Indicator (GG) dial to align indicator arrows with zero (0). Orange color indicates cutting depth in centimeters. White color indicates inches.
  - 3) Raise saw to maximum height. Now as Diamond Blade (H) is lowered, Depth Indicator (GG) will show cutting depth.
  - 4) Fully raise Diamond Blade (H).

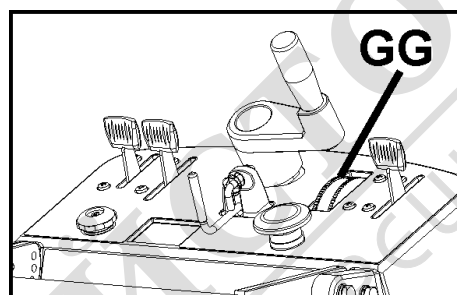
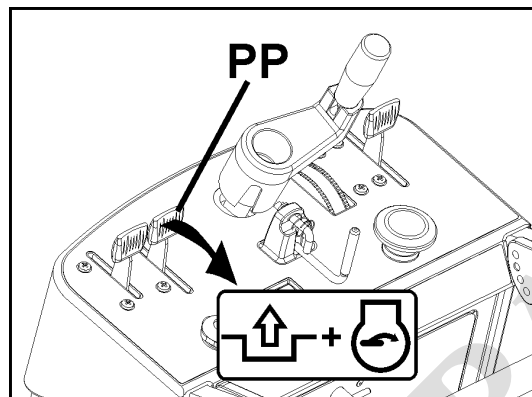

## Starting FS 513:

- Verify that Emergency Stop Switch (AA) AND Engine Start Switch (DD) are in "ON" position. Emergency Stop Switch (AA) should be in outer position (pulled outward from cowl). Engine Start Switch (DD) must be turned to "1" (ON) position. Travel Speed Lever (QQ) is near the "Stop" position.
- Start Engine by engaging Engine Choke Lever, and pulling starting rope. Dis-engage Engine Choke Lever after engine starts. See engine manual for more information.

## Starting FS 520 / FS 524:

- Verify that Emergency Stop Switch (AA) is in outer position (pulled outward from cowl), and Parking Brake (OO) is dis-engaged [Transmission Engagement Lever (PP) moved rearward to Dis-Engaged position]. Travel Speed Lever (QQ) is near the "Stop" position.
- Pull Engine Choke (II) Outward (See engine manual for more information).
- Turn Engine Start Switch (DD) to "Start" position.
- Start Engine. See engine manual for more information.

## After Starting Engine (All Models):

- Visually verify that tool rotation matches directional arrow on blade guard.
- Open Water Control Valve (KK1) FULL open. Verify full water flow, and then adjust for proper amount of water on the blade BEFORE you lower the Blade.
- Make final adjustments to align saw with cutting line. Verify that Guide Wheel (B), and Diamond Blade (H) are both on the cutting line.

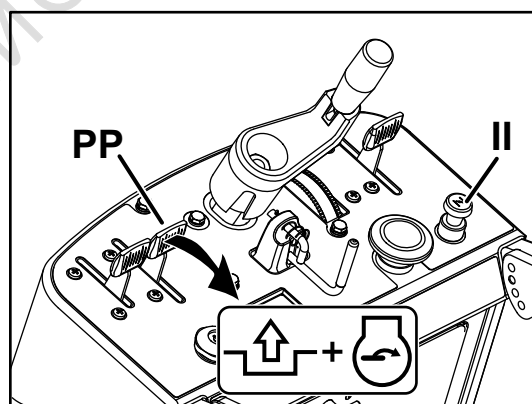

### NOTICE

Parking Brake must be dis-engaged to start engine (FS 520 & FS 524). Move Transmission Engagement Lever (PP) rearward to Dis-Engaged position.

# OPERATION

**If water supply is interrupted, stop cutting immediately. Damage to Diamond Blade (H) could occur.**

- Lower Diamond Blade (H) into the cut by slowly turning Blade Depth Control (EE) COUNTER-CLOCKWISE.
- When desired depth of cut is reached, push Blade Depth Stop (FF) down to lock it to Blade Depth Control (EE) (if desired).
- Make sure Travel Speed Lever (QQ) is near the "Stop" position, then move Transmission Engagement Lever (PP) forward to "Engaged" position.
- Push Travel Speed Lever (QQ) forward until desired travel speed is achieved. Watch Diamond Blade (H) and Guide Wheel (B) carefully to assure that machine stays on cutting line, and that Diamond Blade (H) does not rise out of cutting path.
- When cut is complete, push Travel Speed Lever (QQ) backward until travel stops.
- Dis-engage Blade Depth Stop (FF).
- Raise Diamond Blade (H) out of cut by slowly turning Blade Depth Control (EE) CLOCKWISE.
- Close Water Control Valve (KK).
- Move Transmission Engagement Lever (PP) rearward to "Dis-engaged" position.
- Turn engine to "0" (OFF) position using the Engine Start Switch (DD).

## Extended Periods of Non-Operation (Two Weeks or Greater):

**FS 520 / FS 524: See Battery Maintenance.**

**FS 520 / FS 524: Remove Fuel in Engine:**

- If the machine is not expected to be operated within two weeks the fuel should be removed from the engine. The following procedure can be used:
  1. Open Batter Access Panel (Access Panel not shown in diagram for clarity).
  2. Close engine Fuel Shut-Off Valve (SS). Turn clockwise to close.
  3. Removed Blade and clear area of persons not involved in this work.
  4. Start engine and run at full speed until engine dies because of fuel starvation.

### NOTICE

Failure to drain fuel from engine during extended non-operation periods could cause old fuel to clog carburetor. Additional engine maintenance may result.

### Remove Fuel from Fuel Tank:

- If the machine is not expected to be operated within four or more weeks fuel should be removed from fuel tank. See engine operation manual for information and safety warnings.

### NOTICE

If an urgent situation arises during cutting operations STOP machine immediately using Emergency Stop Switch (AA).

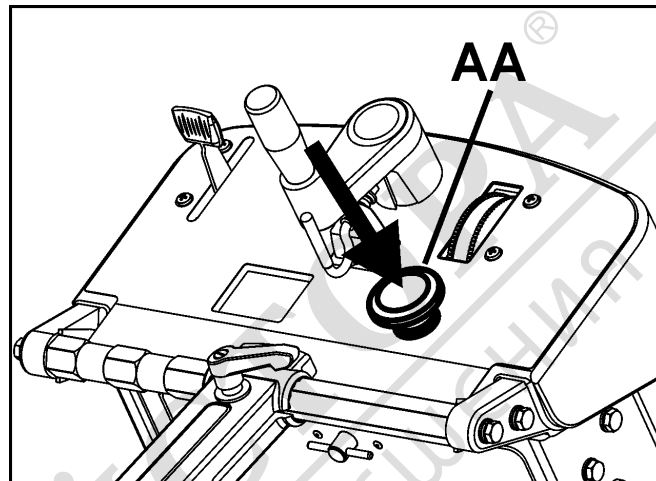

For EMERGENCY STOP of machine, press down EMERGENCY STOP SWITCH (AA).

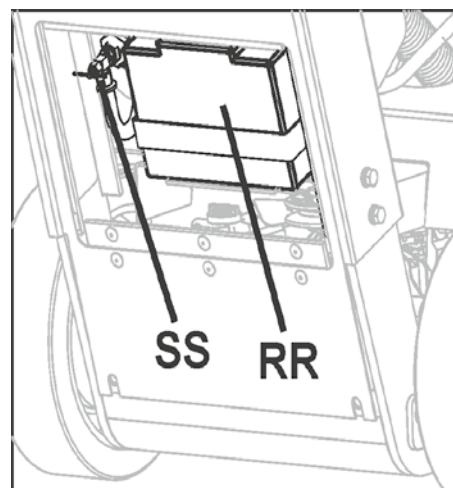

### WARNING!

Gasoline is highly flammable and explosive, and you can be burned or seriously injured when handling fuel.

- Stop engine and keep heat, sparks, and flame away.
- Refuel only outdoors.
- Wipe up spills immediately.

# MAINTENANCE & LUBRICATION

## SCHEDULED MAINTENANCE QUICK REFERENCE:

Before performing any maintenance, ALWAYS park the machine on a level surface with the engine "OFF" and the engine switch set in the "OFF" position. Let the machine cool down! Other maintenance and repairs should only be carried out by a qualified technician.

### SERVICE DAILY:

1. Check engine oil level.
2. Check blade guard for damage.
3. Check engine air filter, replace if dirty. Service sooner if used in dusty conditions.
4. Clean machine daily.

### SERVICE EVERY 50 HOURS:

1. Replace engine oil and filter.
2. Clean engine/motor air fins.
3. Lubricate Depth Control Grease Fitting (X).
4. Check wheels for wear or damage.
5. Check blade drive belt tension.

### FS 513:

#### Replacing Engine Air Filter (S):

If the engine seems weak, produces black smoke or runs unevenly, the air filter may be clogged. For this reason, it is important to clean and replace the air filter regularly. Check engine manual for detailed instructions.

Cleaning/replacement of the air filter is carried out as follows:

1. Undo the wing nut (S1) and lift off the cyclone air filter cowling (S2).

2. Remove the foam rubber pre-filter (S3) and clean using a mild detergent. Squeeze it dry with a clean cloth. Soak it with new engine oil. Squeeze out excess oil.

3. Remove the wing nut (S4) in the air filter and remove the paper filter (S5). Tap the paper filter against a fixed surface to remove dust. If the paper filter is still dirty or damaged, it MUST be replaced.

#### NOTICE

**DO NOT use compressed air over 2 bar / 30 PSI to clean the paper filter.**

**DO NOT wash paper filter.**

**DO NOT oil paper filter.**

4. Refit the air filter as follows:

Mount the paper filter in the air filter housing and tighten the wing nut.

5. Refit foam rubber pre-filter (S3) on the paper filter (S5).

6. Refit with the air filter cowling (S2).

### FS 520 / FS 524:

The air filter on these models are "Snorkel Type" and are supplied by engine manufacture. See engine operation manual for service information. If used in dusty conditions, use the recommended service interval shown in this document.

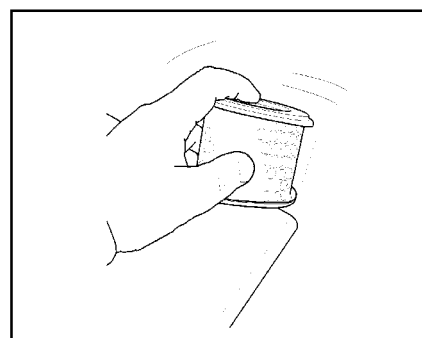
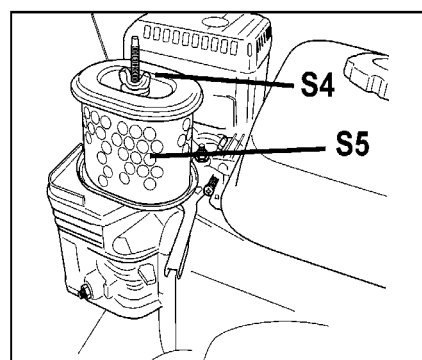
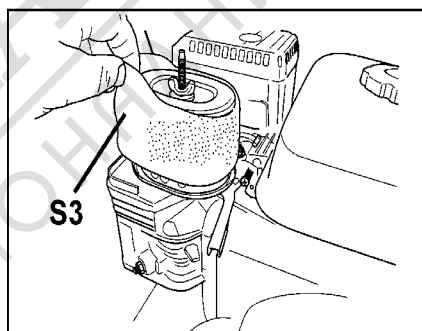
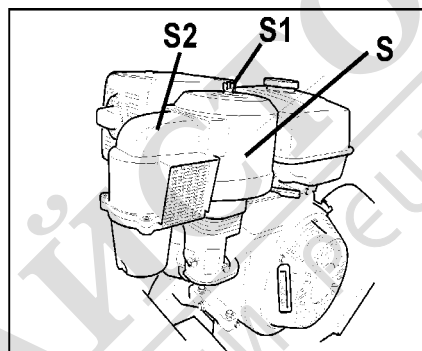

# MAINTENANCE & LUBRICATION

## LUBRICATION:



**Depth Control Grease Fitting (X):** A grease fitting allows lubrication of Blade Depth Control (EE) screw. To access this grease fitting:

- Raise the Diamond Blade (H) to maximum height. Open Tool Compartment (BB), temporarily remove operation manual bag.
- Grease fitting (X) is located near top of Blade Depth Control (EE) Tube.
- Add Grease to the fitting. Raise and lower the machine a few times to circulate the grease through the tube.
- Replace Operation Manual Bag, close Tool Compartment (BB) door.

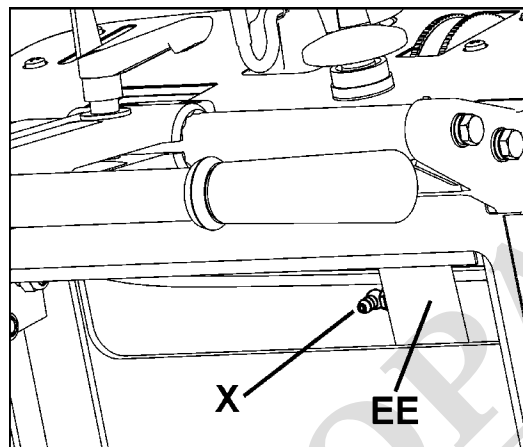

## Engine Oil:

### Checking Engine Oil:



Check that engine oil level is correct. FS 524 ONLY: Start the engine and let it idle for 1 or 2 minutes. Stop the engine and wait for 2 or 3 minutes. See engine operation manual for more information.



#### FS 513:

Engine Oil Dipstick (Z) is located on front of engine. Refill engine oil in dipstick hole. When checking oil level, Engine Oil Dipstick (Z) should not be screwed in. See engine operation manual for more information.

#### FS 520 / FS 524:

Engine Oil Dipstick (Z) is located on front of engine. Refill engine oil in oil filler hole (see engine operation manual). Fully insert Engine Oil Dipstick (Z), then remove it to check oil level. If the oil level is low, remove the oil filler cap, and fill to the upper limit mark on Engine Oil Dipstick (Z) with recommended oil type. See engine operation manual for more information.

Because engine often operates at an angle, check oil level with engine horizontal. Check frequently to ensure that oil level never falls below lower mark on dipstick. 10W30 oil is recommended. See engine operation manual for more information.

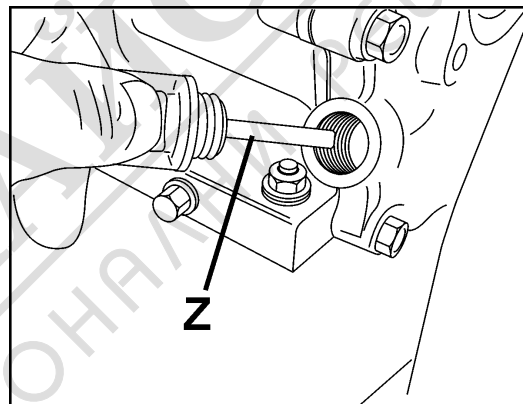

FS 513

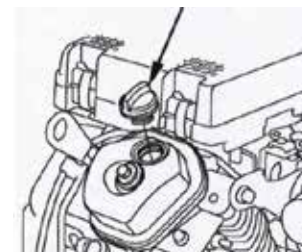
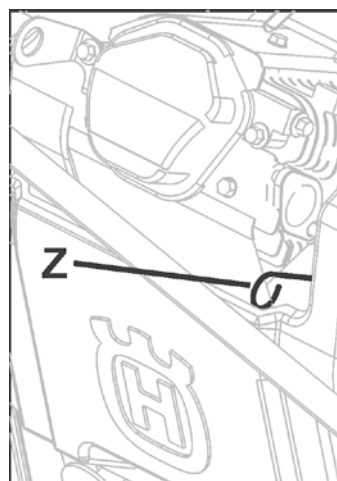

FS 520, FS 524

## MAINTENANCE & LUBRICATION

### Changing Engine Oil:

- Turn machine Start Switch (DD) to OFF (0) position. Let engine cool. Use Depth Control (EE) to tilt machine slightly backwards.
- Reposition Oil Drain Hose (NN) to side of machine. Set a suitable container, large enough to hold engine oil capacity, beside machine to catch oil.
- Open end of Oil Drain Hose (NN), and let oil drain into container. After oil is drained, replace Oil Drain Hose (NN) end, tighten securely, return hose to original position.
- Fill engine with recommended quantity of oil - see engine manual for details.
- Dispose of used oil in an environmentally safe manner.

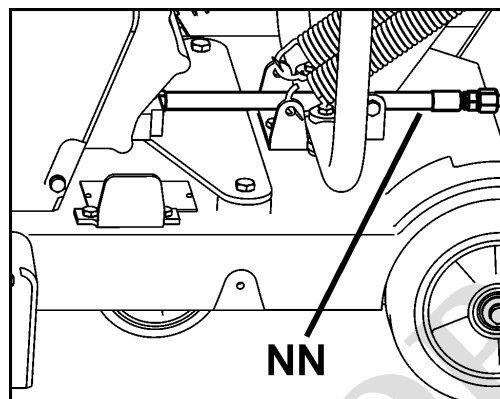

### Battery Maintenance (FS 520 / FS 524):

This engine starting battery (RR) is a sealed unit and will never require the addition of water. Keep the top of the battery and the cable connections clean and free of corrosion. Coat the connections with a high temperature grease or petroleum jelly. Periodically check the battery by measuring its voltage with a DC voltmeter. A fully charged battery will be 12.8 volts. It is recommended that voltage checking and charging be done at the battery cable on the starter motor at the front of the saw.

Charge battery at least once a month. Charging can be done by running engine for at least 30 minutes or connect battery to a trickle charger (2 amps or less) for 8 hours. If battery will not start engine, it is recommended that battery be replaced or charged with a trickle charger (2 amp rating or less).

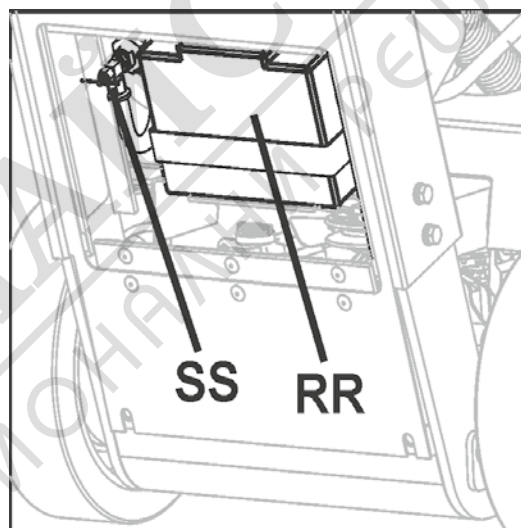

#### NOTICE

A fully charged battery will be 12.8 volts.

Jump starting this equipment from a larger battery or boost charger is not recommended. Doing so could cause permanent damage to the internal battery.

# MAINTENANCE & LUBRICATION

**Blade Shaft Drive Belt Tension:** Drive Belt should be re-tensioned after first few hours of operation. Belt Drive Idler (MM) holds tension on Drive Belt.

**Tools Required:**

- 13mm Wrench (Included with machine).
- 3/8" (9.53mm) Drive Torque Wrench (Not Included)
- 14mm Wrench (Not included with machine).

1. Use 13mm Wrench (U), to remove three (3) M8 bolts that attach Belt Guard (LL). Remove Guard (LL).

2. Use the 13mm & 14mm wrenches to slightly loosen the two (2) bolts that secure the Belt Drive Idler (MM) [bolts indicated by (2) arrows].

3. Attach Torque Wrench to square hole in Belt Drive Idler (MM).

4. Apply a torque to Drive Idler (MM) so that Drive Idler (MM) is forced against the Drive-Belt. Torque to the value shown in diagram 4.

5. Tighten center bolt (CB1) to hold Drive Idler (MM) in position, then tighten remaining bolt (CB2).

6. Reinstall Belt Guard (LL). Use 13mm Wrench (U), to tighten three (3) M8 bolts that attach Belt Guard (LL).

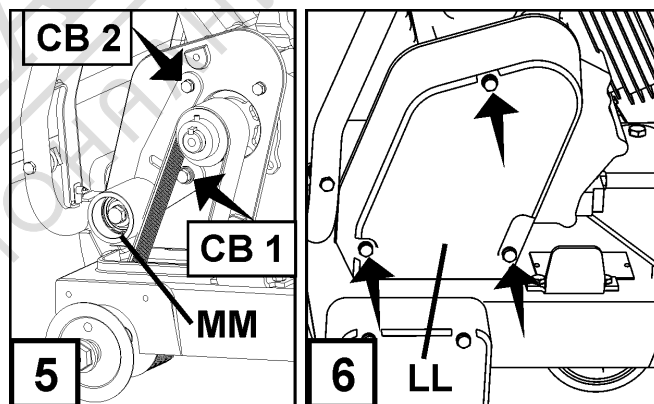
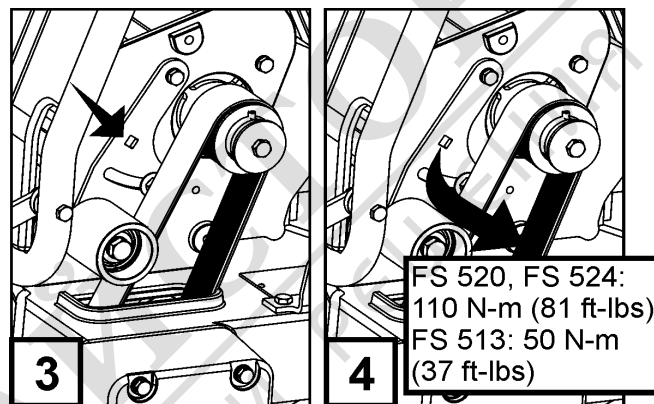
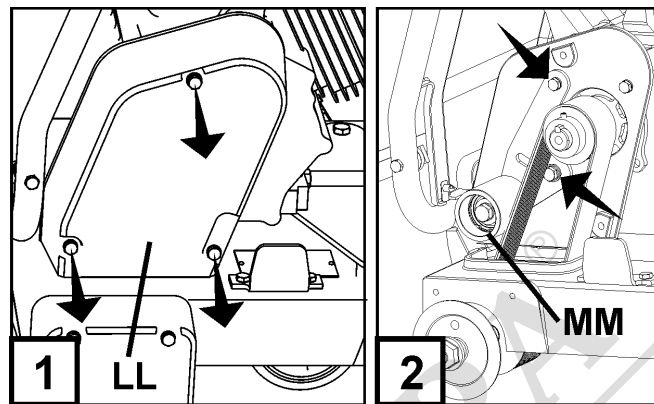

**Governor Speed**

It is critical that Governor and throttle on all internal combustion engines be adjusted properly. Engine speed is preset at factory for proper sawing speed. It is NOT normally necessary to change this setting. It should be periodically verified after machine is placed into service. To change the Governor setting, refer to the engine manual.

**⚠ WARNING!**

**Overspeeding Diamond Blade (H) can result in blade breakage and/or personal injury to operator and bystanders! To assure proper Governor adjustment, determine correct blade shaft speed (RPM) from the adjacent chart. Follow engine manufacturer's instruction procedure for Governor and throttle setting.**

Blade Shaft & Engine Speed		
Model	Blade Shaft RPM	Engine RPM
FS 513	2600	3600
FS 520	2100	3600
FS 524	2100	3600

# MAINTENANCE & LUBRICATION

## Hydrostatic Transmission:

**Service of Hydrostatic Transmission (TT):** Maintenance free for life of machine.

**Transmission Drive Belts:** Remove guards shown in diagram as right to access transmission drive belts.

### • Transmission Drive Tensioner Belt (UU):

#### Belt Tension:

1. Check tension when machine is new.
2. Re-check tension after 1-2 hours of operation and re-tighten to original tension if required - see steps 3-5 below.
3. Loosen Bolts that hold Transmission Drive Tensioner (V V) in place.
4. Move tensioner (V V) toward rear of machine to increase tension.
5. Re-tighten bolts.

#### Belt and Sheave Wear:

Check every 50 hours for wear on belt and sheaves. Replace if worn.

### • Hydrostatic Transmission Belt (WW):

#### Belt Tension:

Checking tension is not required. Hydrostatic Transmission Belt Tensioner (ZZ) is a spring loaded self tensioning idler. Check for wear or damage to idler spring - replace if required.

#### Belt and Sheave Wear:

Check every 50 hours for wear on belt and sheaves. Replace if worn.



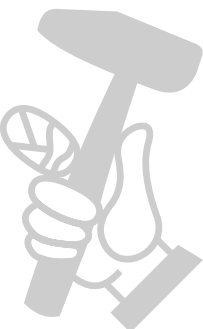
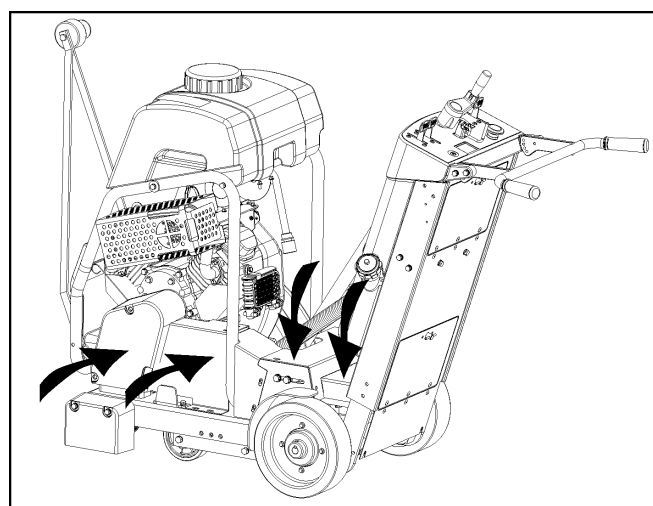
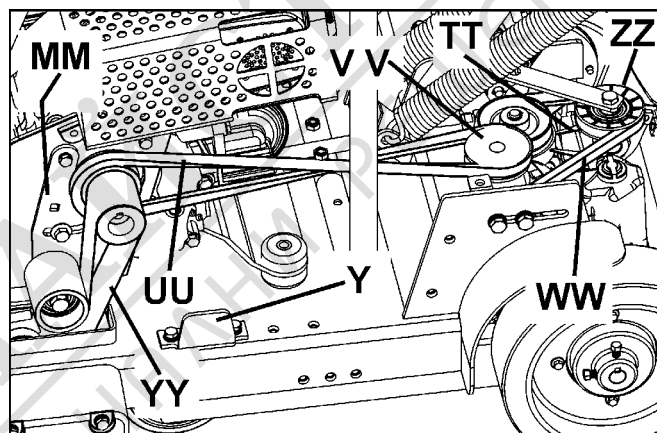
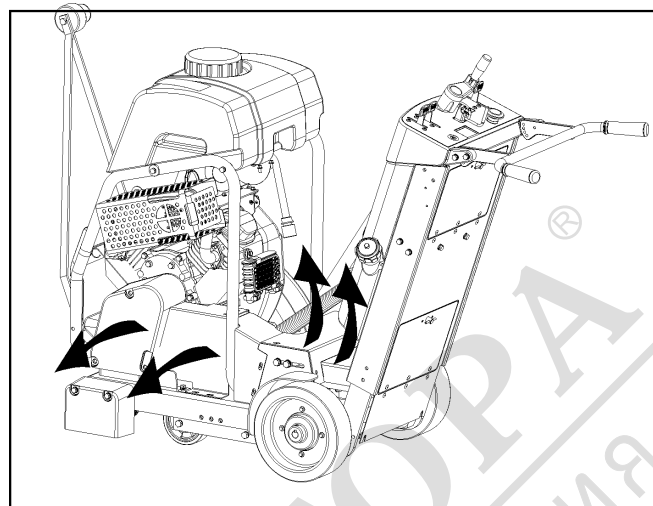

Replace guards shown in diagram at right before starting engine.



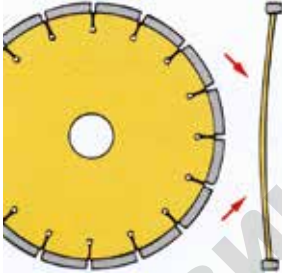

# TROUBLE SHOOTING GUIDE

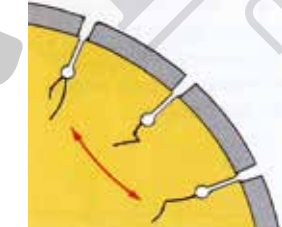
<b>Engine Will Not Start:</b>	
<b>Cause</b>	<b>Action</b>
Electrical switches not in correct position.	Check that BOTH Emergency Stop Switch (AA) and Engine Start Switch (DD) (FS 513) are in "ON" position. Emergency Stop Switch (AA) should be pulled outward from cowl, and Engine Start Switch (DD) turned to "1" (ON) position.
Fuel valve closed.	Open the fuel valve.
Choke valve open.	Close the choke with cold engine.
Fuel tank empty.	Fill with fuel.
Contamination, or water ice in fuel system.	Clean tank, fuel lines and carburetor. Fill tank with fresh fuel.
Buildup on spark plug electrodes.	Check electrode gap and clean.
Engine has no power or runs unevenly. Air filter Clogged.	Clean or replace the air filter.

<b>Diamond Blade Trouble Shooting:</b>	
<b>Problem</b>	<b>Cause &amp; Action</b>
<p>Loss of Tension in Diamond Blade</p> 	<p>Blade being used on misaligned saw. Check for proper saw alignment.</p> <p>Blade is excessively "hard" for material being cut, creating stress on steel blade center. Check that blade is correct for material being cut.</p> <p>Different diameter or undersize blade flanges creates uneven pressure on blade center. Use proper size flange on each side of blade. Never use worn or damaged flanges.</p> <p>Blade operated at improper speed (R.P.M.). Make certain blade shaft is turning at the proper speed (R.P.M.) for blade size. Check R.P.M. using a tachometer.</p> <p>Blade improperly mounted on arbor. Could become bent when flanges are tightened.</p>
<p>Segment Loss</p> 	<p>Blade is too "hard" for material being cut. Use "softer" blade specification.</p> <p>Overheated blade, detected as "blue" color on steel center. Check that water supply is adequate and not blocked.</p> <p>Saw is twisted while cutting. Saw only in a straight line.</p> <p>Blade Bore is worn to an eccentric shape (ovalized). Replace worn blade and worn spindle.</p> <p>Segment knocked off during mounting or transport. Avoid rough handling of diamond blade. Never transport the machine with the diamond blade mounted.</p>
<p>Cracked Blade Core</p> 	<p>Blade is too "hard" for material being cut. Use "softer" blade specification.</p> <p>Overheated blade, detected as "blue" color on steel center. Check that water supply is adequate and not blocked.</p> <p>Saw is twisted while cutting. Saw only in a straight line.</p> <div style="border: 1px solid black; padding: 5px; margin-top: 10px;"> <p style="text-align: center;"><b>! WARNING!</b></p> <div style="display: flex; align-items: center;">  <p>DO NOT use damaged diamond blades! Death or injury could occur if machine is operated using damaged diamond blades!</p> </div> </div>
<p>Cracked Blade Segments</p> 	<p>Blade is too "hard" for material being cut. Use "softer" blade specification.</p> <p>Blade operated at improper speed (R.P.M.). Make certain blade shaft is turning at the proper speed (R.P.M.) for blade size. Check R.P.M. using a tachometer.</p>

# WIRING DIAGRAM (FS 520, FS 524)

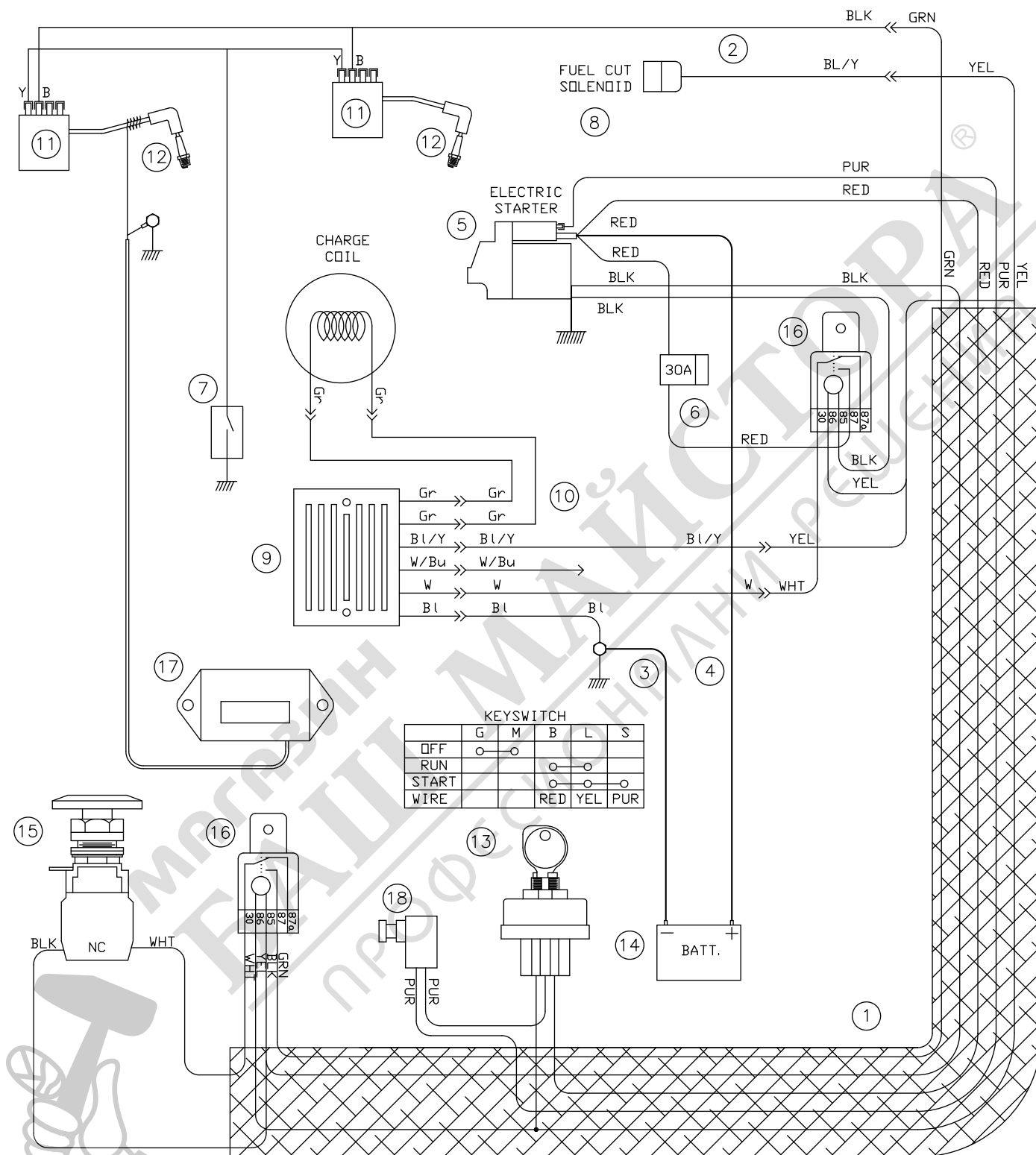

---

## WIRING DIAGRAM (FS 520, FS 524)

---

ITEM	PART NO	QTY	DESCRIPTION
1	502304815	1	WIRE HARNESS
2		1	WIRE HARNESS, ENGINE, HONDA
3	542182253	1	CABLE, BATTERY NEGATIVE
4	542182254	1	CABLE, BATTERY POSITIVE
5		1	STARTER, HONDA
6	542198815	1	FUSE, 30A
7		1	SWITCH, ENG. OIL LEVEL, HONDA
8		1	FUEL CUT SOLENIOD, HONDA
9		1	REGULATOR, HONDA
10		1	WIRE HARNESS, REGULATOR, HONDA
11		2	COIL, IGNITION HONDA
12		2	SPARK PLUG
13	542177920	1	SWITCH, IGNITION
14	541208318	1	BATTERY, 12 VOLT
15	505417701	1	SWITCH, PALM STOP
16	542166708	2	RELAY, NO/NC
17	539300556	1	TACH/HOURMETER
18	542204052	1	NEUTRAL START SWITCH

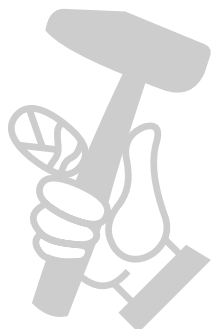

# WIRING DIAGRAM (FS 513)

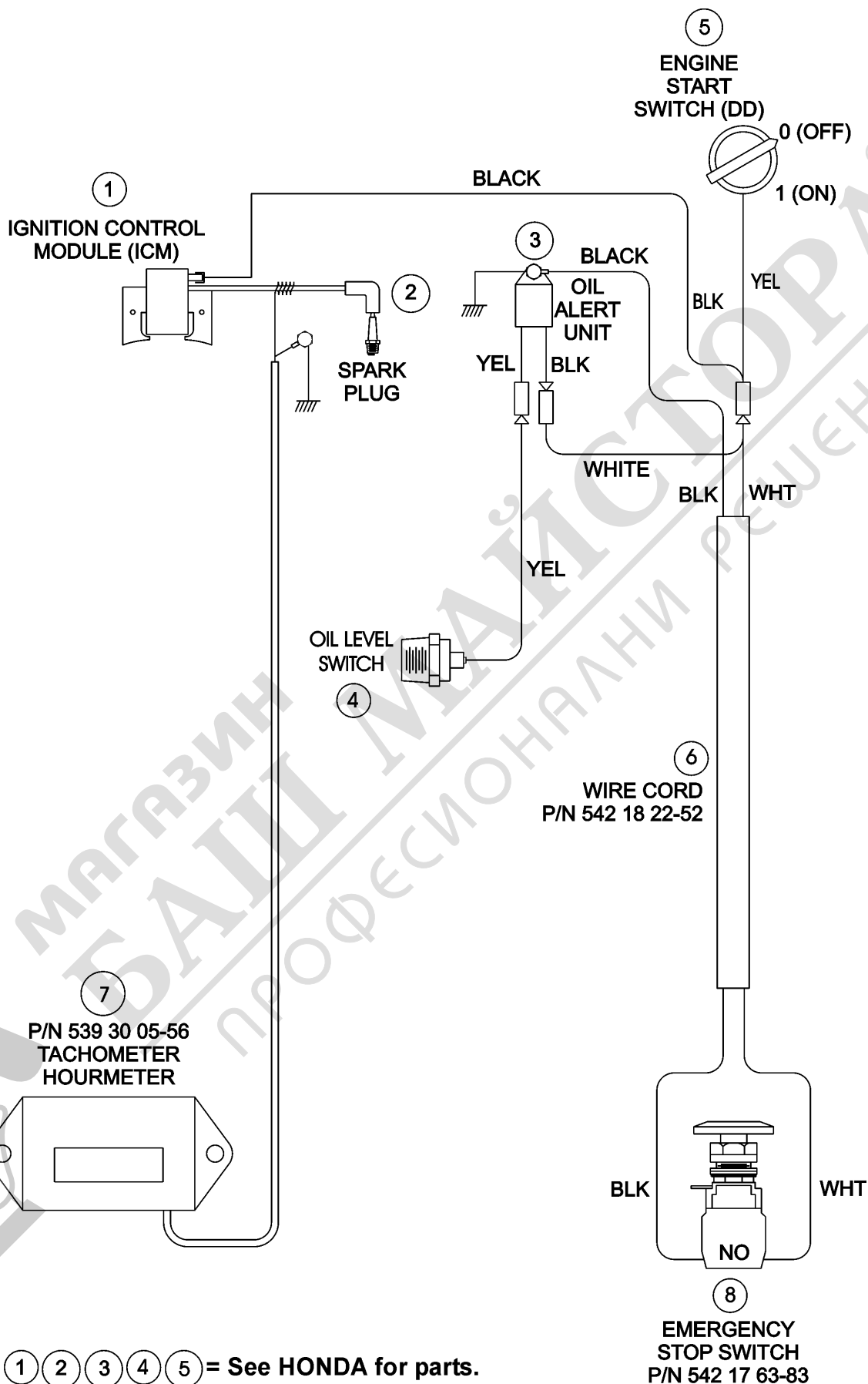

**1 2 3 4 5** = See HONDA for parts.

## TECHNICAL DATA

### FS 513

Noise emissions (see note 1)	
Sound power level, measured dB(A)	104
Sound power level, guaranteed dB(A)	105
Sound levels (see note 2)	
Sound pressure level at the operators ear, dB(A)	87
Vibration levels, $a_{hv}$ (see note 3)	
Handle right, $m/s^2$	3,1
Handle left, $m/s^2$	3,2

Note 1: Noise emissions in the environment measured as sound power ( $L_{WA}$ ) in conformity with EC directive 2000/14/EC.

Note 2: Noise pressure level according to EN 13862. Reported data for noise pressure level has a typical statistical dispersion (standard deviation) of 1.0 dB(A).

Note 3: Vibration level according to EN 13862. Reported data for vibration level has a typical statistical dispersion (standard deviation) of 1  $m/s^2$ .

### FS 520

Noise emissions (see note 1)	
Sound power level, measured dB(A)	109
Sound power level, guaranteed dB(A)	110.5
Sound levels (see note 2)	
Sound pressure level at the operators ear, dB(A)	89
Vibration levels, $a_{hv}$ (see note 3)	
Handle right, $m/s^2$	2.5
Handle left, $m/s^2$	2.8

Note 1: Noise emissions in the environment measured as sound power ( $L_{WA}$ ) in conformity with EC directive 2000/14/EC.

Note 2: Noise pressure level according to EN 13862. Reported data for noise pressure level has a typical statistical dispersion (standard deviation) of 1.5 dB(A).

Note 3: Vibration level according to EN 13862. Reported data for vibration level has a typical statistical dispersion (standard deviation) of 1  $m/s^2$ .

### FS 524

Noise emissions (see note 1)	
Sound power level, measured dB(A)	109
Sound power level, guaranteed dB(A)	110.5
Sound levels (see note 2)	
Sound pressure level at the operators ear, dB(A)	89
Vibration levels, $a_{hv}$ (see note 3)	
Handle right, $m/s^2$	2.5
Handle left, $m/s^2$	2.8

Note 1: Noise emissions in the environment measured as sound power ( $L_{WA}$ ) in conformity with EC directive 2000/14/EC.

Note 2: Noise pressure level according to EN 13862. Reported data for noise pressure level has a typical statistical dispersion (standard deviation) of 1.5 dB(A).

Note 3: Vibration level according to EN 13862. Reported data for vibration level has a typical statistical dispersion (standard deviation) of 1  $m/s^2$ .

## TECHNICAL DATA



### Machine Mass

Model	Nominal Mass-kg (lbs)	Maximum Mass-kg (lbs)
FS 513	187 (412)	213 (470)
FS 520	210 (462)	236 (520)
FS 524	213 (469)	239 (527)

### Blade Shaft & Engine Speed

Model	Blade Shaft RPM	Engine RPM
FS 513	2600	3600
FS 520	2100	3600
FS 524	2100	3600

### ! WARNING!

USE ONLY Blades (H) marked with a maximum operating speed greater than blade shaft speed of machine.

DO NOT change to a larger size blade without changing to proper belts and pulleys!

### Cutting Depth

Blade Size	Maximum Blade Cutting Depth
250 mm (10")	68 mm (2-3/4")
300 mm (12")	93 mm (3-3/4")
350 mm (14")	118 mm (4-3/4")
400 mm (16")	146 mm (5-3/4")
450 mm (18")	164 mm (6-3/4")
500 mm (20")*	192 mm (7-3/4")*
600 mm (24")**	247 mm (9-3/4")**

\*FS 520 & FS 524 Only,    \*\*FS 524 Only

### Fuel Tank Capacity

Model	Capacity
FS 513	6,5 Liters (1.72 U.S. Gallons) (1,43 U.K. Gallons)
FS 520	7,9 Liters (2.1 U.S. Gallons) (1,7 U.K. Gallons)
FS 524	7,9 Liters (2.1 U.S. Gallons) (1,7 U.K. Gallons)

### Water Tank Capacity

25 Liters (6.6 U.S. Gallons) (5.5 U.K. Gallons)

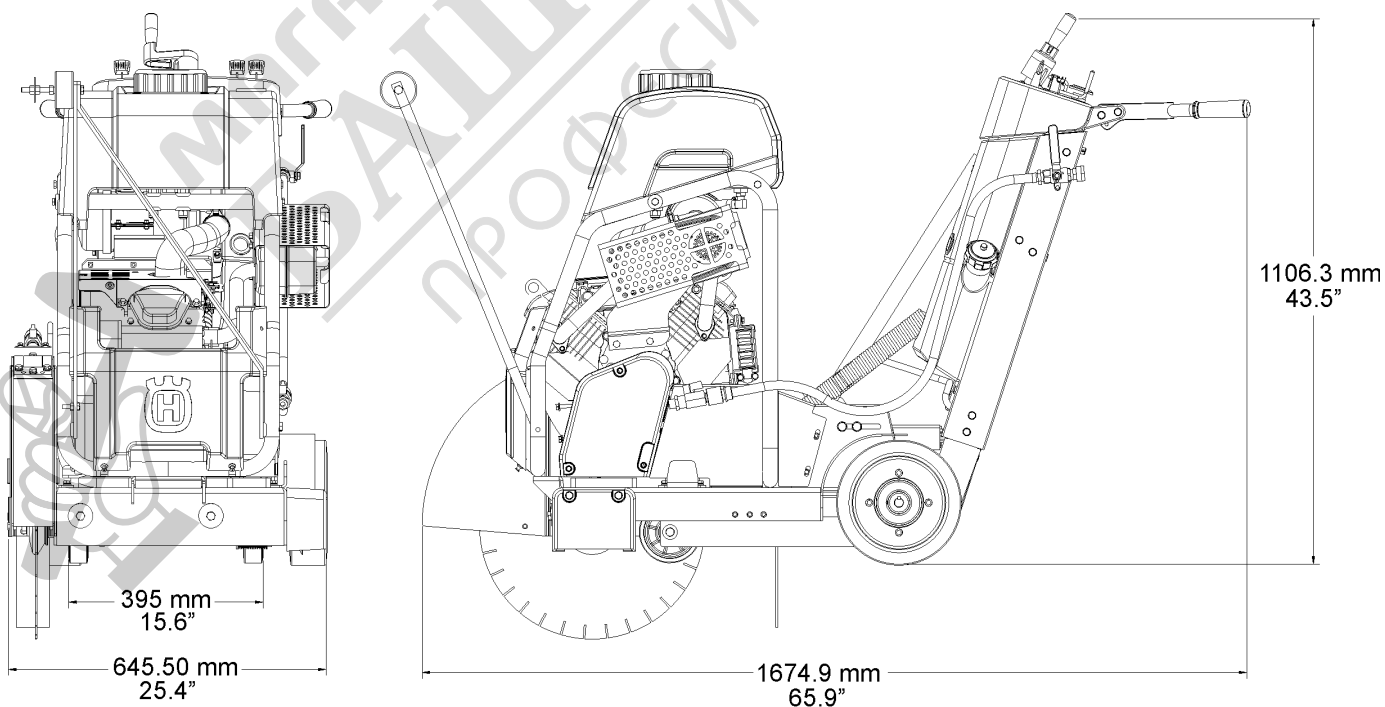

---

## ACCESSORIES

---

**Dual Pointer Assembly**  
542 20 22-70 Complete Kit

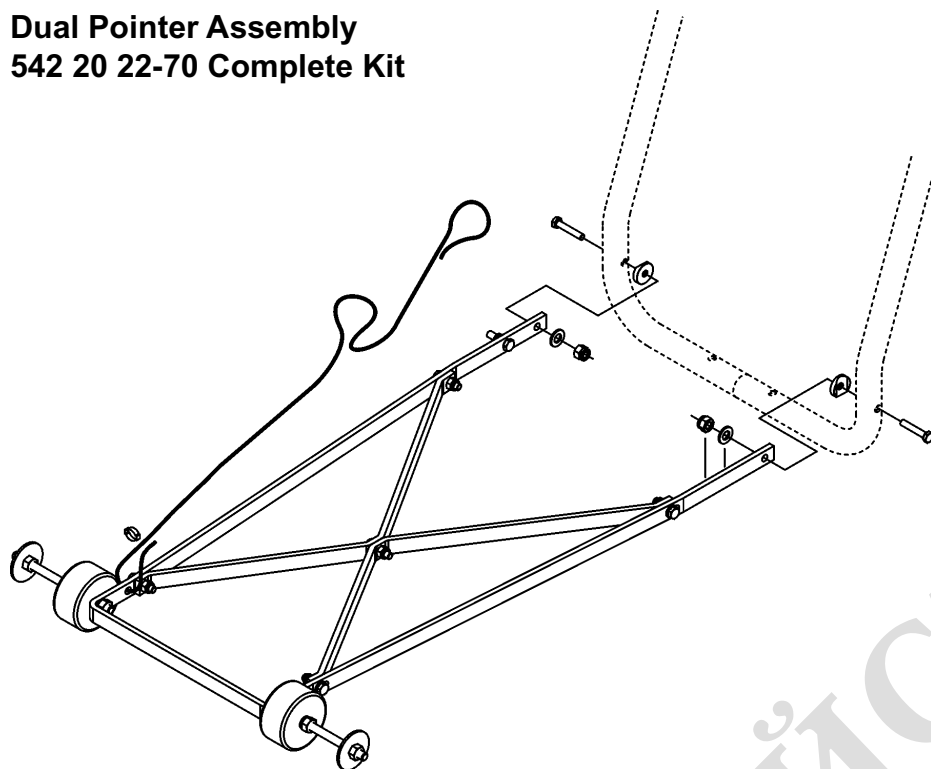

**Water Tank Assembly**  
541 20 82-86 Complete Kit

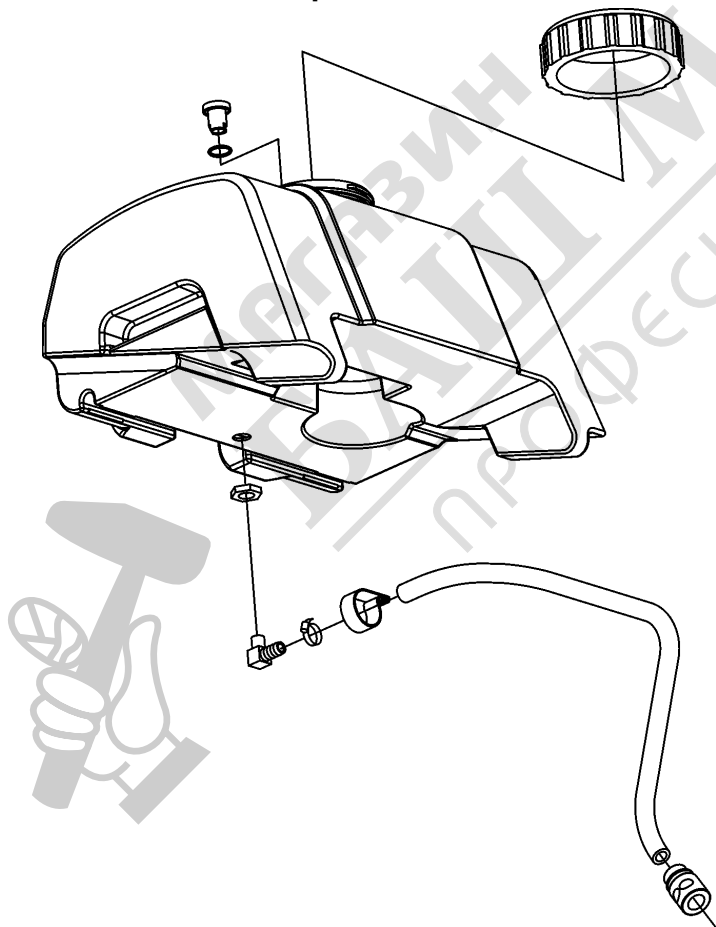

---

## CONFORMITY CERTIFICATES

---

**American National Standards Institute** : For units used in the United States, this machine has been designed to comply with American National Standards Institute ANSI B7.1-2000, "Safety Requirements for the Use, Care and Protection of Abrasive Wheels". This standard can be purchased by contacting the American National Standards Institute at the address shown below:

American National Standards Institute  
25 West 43rd Street, 4th floor  
New York, NY 10036

Telephone: 212.642.4900  
Fax: 212.398.0023  
www.ansi.org

**CALIFORNIA AIR RESOURCES BOARD (CARB)**: This machine is considered a preempt Off-Road Application as relating to CARB standards. Under construction equipment, and in particular, as a concrete saw (Saws: concrete, masonry, cutoff), with engine power less than 19KW (25 hp), CARB standards do not apply to this machine.

For more information see the website

<http://www.arb.ca.gov/msprog/offroad/preempt.htm>

### EC DECLARATION OF CONFORMITY

**Husqvarna AB**, SE-433 81 Göteborg, Sweden, tel: +46-31-949000, declares under sole responsibility that the **Husqvarna FS 513, FS 520, FS 524** dating from 2010 serial numbers and onwards (the year is clearly stated on the rating plate, followed by the serial number), complies with the requirements of the COUNCIL'S DIRECTIVE:

- of May 17, 2006 "relating to machinery" 2006/42/EC
- of December 15, 2004 "relating to electromagnetic compatibility" 2004/108/EC.
- of May 8, 2000 "relating to the noise emissions in the environment" 2000/14/EC.

The following standards have been applied: EN ISO 12100:2003, EN 55014-1:2006, EN 55014-2/A1:2001, EN 61000-3-2:2006, EN 61000-3-3/A1/A2:2005, EN 13862/A1:2009, EN ISO 14982:2009.

Husqvarna January 3, 2011



Henric Andersson

Vice President, Head of Power Cutters and Construction Equipment

(Authorized representative for Husqvarna AB and responsible for technical documentation.)



---

## CONTACT INFORMATION

---



### Construction Products, North America

#### Corporate Office

17400 West 119th Street, Olathe, Kansas 66061 USA

Corporate Office: 913-928-1000

Corp. Office Fax: 913-438-7951

[www.husqvarna.com](http://www.husqvarna.com)

For local service, please contact your local Husqvarna Construction Products representative.

Para efectuar un servicio local, póngase en contacto con su representante local de Husqvarna Construction Products.

Pour toute réparation, contacter le représentant local de Husqvarna Construction Products.

Für Service vor Ort wenden Sie sich bitte an Ihren örtlichen Vertreter von Husqvarna Construction Products.

Neem voor plaatselijke service contact op met uw plaatselijke vertegenwoordiger van de constructieproducten van Husqvarna.

Per assistenza, rivolgersi al rappresentante di zona della Husqvarna Construction Products.

För service på platsen, kontakta din lokala representant för Husqvarna Construction Products.

Para obter serviço técnico local, contactar o representante da Husqvarna Construction Products

### Europa / Europe:

#### Husqvarna Construction Products

SE-433 81 Partille, Sweden

Tel: +46 31 94 90 00

Fax: +46 31 94 90 50

### Asia Pacific:

#### Husqvarna Construction Products, Australia Pty Ltd

25-31 Kinkaid Avenue,  
North Plympton, Adelaide,  
South Australia 5037

Tel: +61 (0)8 8375 1000

Fax: +61 (0)8 8371 0990

### The Americas:

#### Husqvarna Construction Products, North America

17400 West 119th Street, Olathe, Kansas 66061 USA

Toll-Free Telephone: 800-288-5040, Telephone: 913-928-1300

Fax: 913-438-7938

