



Husqvarna®



FS5000 D

EN	Operator's manual	2-47
DE	Bedienungsanweisung	48-95
FR	Manuel d'utilisation	96-144
NL	Gebruiksaanwijzing	145-191



Contents

Introduction.....	2	Transportation, storage and disposal.....	37
Safety.....	8	Technical data.....	41
Operation.....	13	Accessories.....	46
Maintenance.....	25	EC Declaration of Conformity.....	47
Troubleshooting.....	37		

Introduction

Product description

The product is a walk behind floor saw with a combustion engine. The product has an adjustable pointer that lets you see the operation clearly and makes it easy to cut straight. The product has a control panel with a digital display that monitors all functions.

Intended use

This product is used with diamond blades for wet cutting to cut hard floor surface materials such as concrete, asphalt and stone. All other use is incorrect.

The product is used in industrial operations by operators with experience.

Product overview, left side

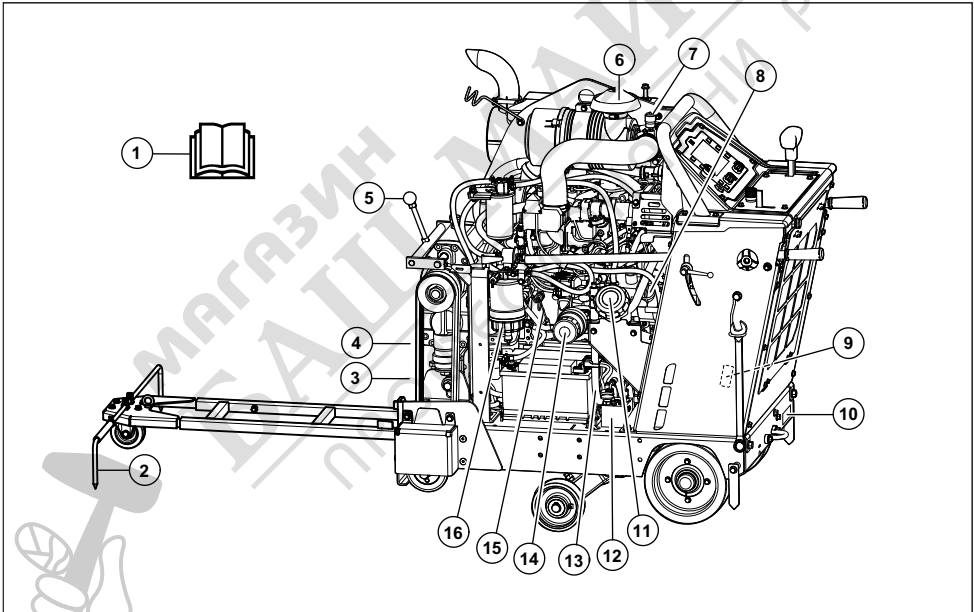

- | | |
|---|---|
| 1. Operator's manual | 9. Type plate for US/Canada |
| 2. Adjustable pointer | 10. Type plate for EU |
| 3. Water drain valve for the gearbox | 11. Fuel tank cap |
| 4. Bolts for belt tension | 12. Transmission bypass valve |
| 5. Gearshift lever, 3-speed gearbox model | 13. Drain hose for engine oil |
| 6. Air filter | 14. Engine oil filter |
| 7. Air filter indicator | 15. Engine oil dipstick |
| 8. Oil tank cap for engine oil | 16. Water separator for the fuel filter |

Product overview, right side

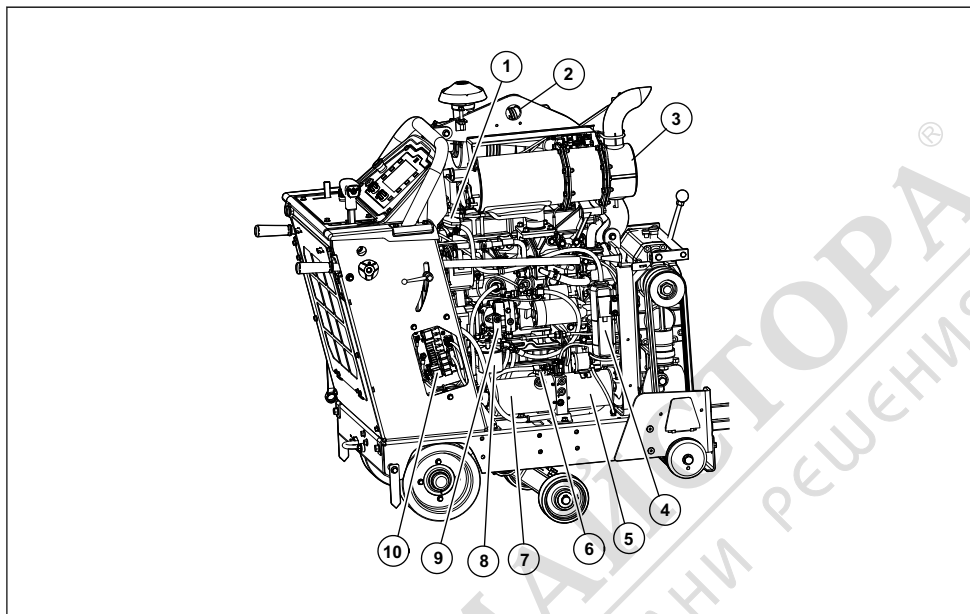

1. Radiator coolant lid
2. Lifting eye
3. Muffler
4. Container for radiator coolant spill
5. Pump for the hydraulic lift
6. Hydraulic reservoir opening
7. Hydraulic reservoir
8. Hydraulic system filter
9. Pump for the hydrostatic transmission
10. Relay and fuse box



Product overview, rear

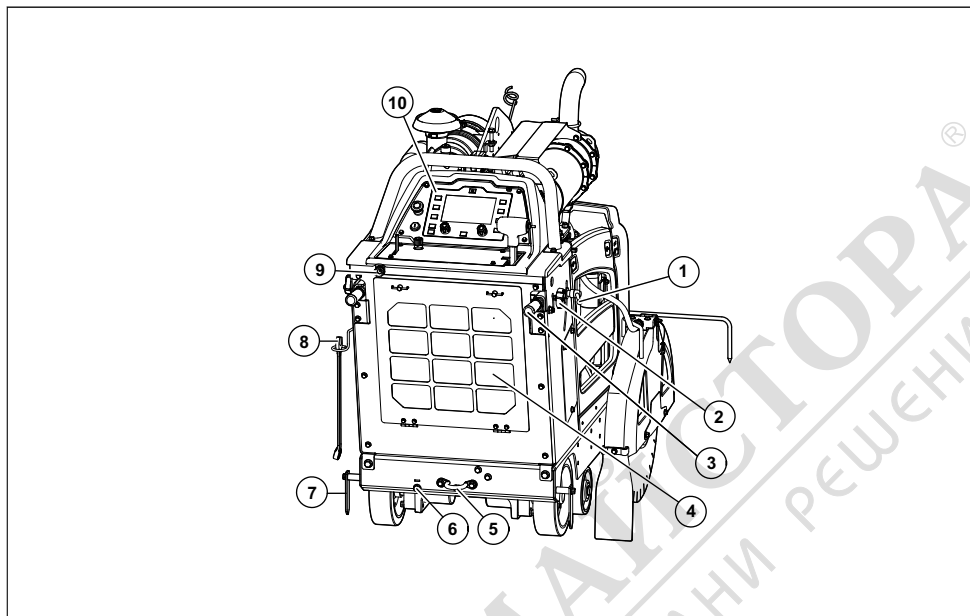

1. Locking knob for operation handles, adjustment in height
2. Locking knob for operation handles, adjustment in length
3. Operation handles
4. Radiator air filter
5. Rear tie-down bracket
6. Manual axle adjustment
7. Rear pointer
8. Blade shaft wrench
9. Water inlet
10. Control panel

Note: There is also a tie-down bracket at the front of the product.



Overview of the controls and the control panel

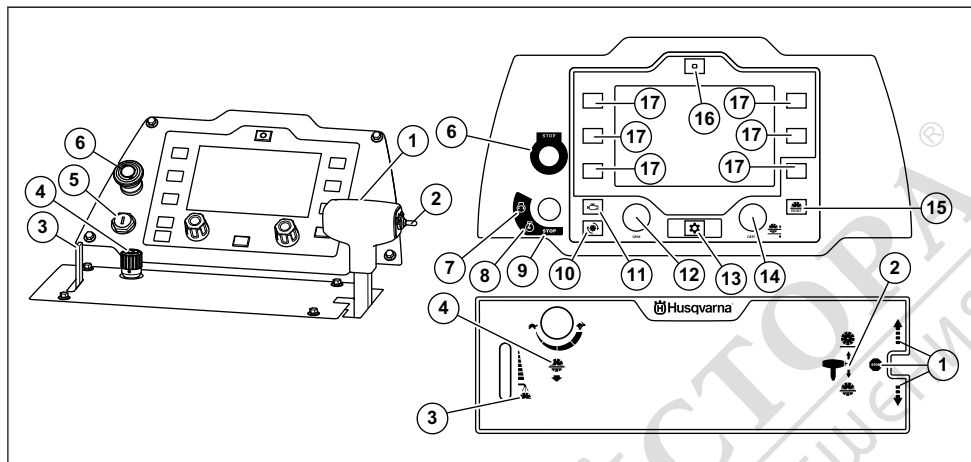

1. Lever for speed control. Forward, rearward and transmission stop *
2. Switch for cutting depth adjustment *
3. Lever for the water cooling system for the cutting blade *
4. Knob for adjustment of the blade lowering speed *
5. Engine start switch
6. Machine stop button *
7. Engine start position *
8. Ignition on position *
9. Engine stop position *
10. Button to show blade speed in rpm on the display *
11. Button to show engine speed in rpm on the display *
12. Knob for the throttle control
13. Menu button *
14. Knob for adjustment of the blade depth stop *
15. Reset button for the blade depth stop *
16. E-track reset button * (optional)
17. Selection button

* = Refer also to *Symbols on the product on page 5.*

Symbols on the product



WARNING: This product can be dangerous and cause serious injury or death to the operator or others. Be careful and use the product correctly.



Read the operator's manual carefully and make sure that you understand the instructions before you use this product.



Use hearing protection, eye protection and respiratory protection. Refer to *Personal protective equipment on page 10.*



All displacement of the machine outside the cutting area shall be carried out with the tool not in rotation.



Remove the cutting blade before transportation and before you lift the product, to prevent damage to the cutting blade.



The blade guards must always be installed on the product. Do not let more than 180° of the cutting blade show.



Make sure that the cutting blade is not blunt or has damages, such as cracks.



Make sure that the cutting blade is applicable to the same speed or a higher speed than the value given on the product type plate. A cutting blade that is operated at too high speed can break and cause injury or damage.



Do not use the product near flammable material or gases.



The dust can cause health problems. Use an approved respiratory protection. Do not breathe exhaust fumes. Do not use a combustion engine product indoors or in areas that do not have sufficient airflow.



Hot surface.



Keep body parts away from the cutting blade and other moving parts.



Risk of cut injuries. Keep all body parts away from the cutting blade.



Ultra-low-sulfur diesel fuel only.



Engine oil.



Dipstick.



Do not lift the saw when you examine the engine oil level.



Make sure that the saw is level without cutting blade when you examine the engine oil level.



The arrow on the blade guard shows the direction of rotation of the cutting blade.



Always lift the product at the lifting eye.



Transmission stop.

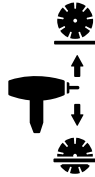

Switch for cutting depth adjustment.



Lever for the water cooling system.



Knob for adjustment of the blade lowering speed.



Slow.



Fast.



Machine stop.



Engine starts.



Ignition on.

STOP Engine stops.



Show blade speed in rpm on the display.



Show engine speed in rpm on the display.



Menu button.



Knob for adjustment of the blade depth stop.



Reset button for the blade depth stop.



Reset button for the E-track adjustment (optional).



This product complies with applicable EC Directives.



Noise emission to the environment complies with applicable EC Directives. The noise emission of the product is specified in *Technical data on page 41* and on the label.

Note: Other symbols/decals on the product refer to certification requirements for some markets.

Symbols on the control panel display



E-track adjustment, left (optional).



E-track adjustment, right (optional).



Water safety system ON/OFF. The water safety system monitors the water pressure to the water cooling system for the cutting blade. If the water pressure decreases, the water safety system stops the cutting blade.



Engage/disengage blade clutch. This function is not standard on all product variants.



Blade depth stop.

Warning symbols on the control panel display



Machine stop engaged. Reset the machine stop button and cycle ignition.



The battery does not charge.



Low fuel level.



Preheating. Refer to the engine manual for more information.



No water pressure to the water cooling system for the cutting blade.



Low engine oil pressure.



Engine stop. The operation cannot continue.



Engine too hot. The operation cannot continue. Refer to the engine manual for more information.



Moderate engine problem. The operation can continue.



Engine failure. Refer to the engine manual for more information.



Regeneration is necessary. Refer to *Stationary regeneration standby on page 36*.



Error code not related to the engine.



Failure in the NOx Diagnostic Control System.

Type plate EU

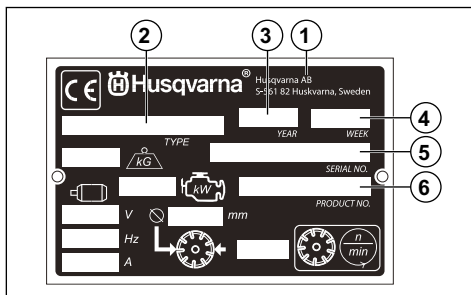

1. Manufacturer
2. Product type

3. Production year
4. Production week
5. Serial number
6. Product number

Product liability

As referred to in the product liability laws, we are not liable for damages that our product causes if:

- the product is incorrectly repaired.
- the product is repaired with parts that are not from the manufacturer or not approved by the manufacturer.

- the product has an accessory that is not from the manufacturer or not approved by the manufacturer.
- the product is not repaired at an approved service center or by an approved authority.

Euro V Emissions



WARNING: Tampering with the engine voids the EU type-approval of this product.

Safety

Safety definitions

Warnings, cautions and notes are used to point out specially important parts of the manual.



WARNING: Used if there is a risk of injury or death for the operator or bystanders if the instructions in the manual are not obeyed.



CAUTION: Used if there is a risk of damage to the product, other materials or the adjacent area if the instructions in the manual are not obeyed.

Note: Used to give more information that is necessary in a given situation.

General safety instructions



WARNING: Read the warning instructions that follow before you use the product.

- This product is a dangerous tool if you are not careful or if you use the product incorrectly. This product can cause serious injury or death to the operator or others. Before you use the product, you must read and understand the contents of this operator's manual.
- Save all warnings and instructions.
- Comply with all applicable laws and regulations.
- The operator and the employer of the operator must know and prevent the risks during operation of the product.
- Do not let a person operate the product unless they read and understand the contents of the operator's manual.
- Do not operate the product unless you receive training before use. Make sure that all operators receive training.
- Only let approved persons operate the product.

- The operator is responsible for accidents that occur to other persons or their property.
- Do not use the product if you are tired, ill, or under the influence of alcohol, drugs or medicine.
- Always be careful and use your common sense.
- This product produces an electromagnetic field during operation. This field can under some circumstances interfere with active or passive medical implants. To decrease the risk of serious injury or death, we recommend persons with medical implants to speak to their physician and the medical implant manufacturer before operating this product.
- Keep the product clean. Make sure that you can clearly read signs and decals.
- Do not use the product if it is defective.
- Do not do modifications to this product.
- Do not operate the product if it is possible that other persons have done modifications to the product.

Safety instructions for operation



WARNING: Read the warning instructions that follow before you use the product.

- Read the warning instructions that are supplied with the cutting blade by the cutting blade manufacturer.
- Make sure that the product is assembled correctly.
- Do not operate the product without the blade guard and the protective covers installed.
- Incorrect operation of the product can cause the cutting blade to break and cause injury or damage.
- Make sure that you know how to stop the engine quickly in an emergency.
- Use personal protective equipment. Refer to *Personal protective equipment on page 10*.
- Make sure that only approved persons are in the work area.
- Make sure that electrical cables in the work area are not live.
- Keep the work area clean and bright.

- Before you operate the product, find out if there are hidden wires, cables and pipes in the work area. If the product hits a hidden object, stop the engine immediately and examine the product and the object. Do not start to operate the product again until you know that it is safe to continue.
- Do not use the product in bad weather conditions, such as thick fog, heavy rain, strong wind or intense cold. To do work in bad weather makes you tired and can cause dangerous conditions, for example slippery surfaces.
- Make sure that you are in a safe and stable position during operation.
- Do not use the product in areas where fire or explosions can occur.
- The product can cause objects to eject at high speed. Make sure that all persons in the work area use approved personal protective equipment. Remove loose objects from the work area.
- The exhaust fumes from the engine contain carbon monoxide which is an odourless, poisonous and very dangerous gas. Do not use a combustion engine product indoors or in areas that do not have sufficient airflow.
- Before you go away from the product, stop the engine and make sure that there is no risk of accidental start.
- The product does not have a parking brake. Do not go away from the product if it is on a slope. If it is necessary to park the product on a slope, make sure that the product is sufficiently attached and cannot move.
- Be very careful during operation on slopes. The product is heavy and can cause serious injury if it falls.
- Make sure that no material can become loose and cause injury to the operator.
- Make sure that clothes, long hair and jewelry do not get caught in moving parts.
- Do not operate the product unless you can get aid if an accident occurs.

Exhaust fumes safety



WARNING: Read the warning instructions that follow before you use the product.

- The exhaust fumes from the engine contain carbon monoxide which is an odourless, poisonous and very dangerous gas. To breathe carbon monoxide can cause death. Because carbon monoxide is odourless and cannot be seen, it is not possible to sense it. A symptom of carbon monoxide poisoning is dizziness, but it is possible that a person becomes unconscious without warning if the quantity or concentration of carbon monoxide is sufficient.
- Exhaust fumes that you can see or smell also contain carbon monoxide.

- Do not use a combustion engine product indoors or in areas that do not have sufficient airflow.

Vibration safety



WARNING: Read the warning instructions that follow before you use the product.

- During operation of the product, vibrations go from the product to the operator. Regular and frequent operation of the product can cause or increase the degree of injuries to the operator. Injuries can occur in fingers, hands, wrists, arms, shoulders, and/or nerves and blood supply or other body parts. The injuries can be debilitating and/or permanent, and can increase gradually during weeks, months or years. Possible injuries include damage to the blood circulation system, the nervous system, joints, and other body structures.
- Symptoms can occur during operation of the product or at other times. If you have symptoms and continue to operate the product, the symptoms can increase or become permanent. If these or other symptoms occur, get medical aid:
 - Numbness, loss of feeling, tingling, pricking, pain, burning, throbbing, stiffness, clumsiness, loss of strength, changes in skin color or condition.
- Symptoms can increase in cold temperatures. Use warm clothing and keep your hands warm and dry when you operate the product in cold environments.
- Do maintenance on and operate the product as given in the operator's manual, to keep a correct vibration level.
- Keep your hands on the handle or handles only. Keep all other body parts away from the product.
- Stop the product immediately if strong vibrations suddenly occurs. Do not continue the operation before the cause of the increased vibrations is removed.

Noise safety



WARNING: Read the warning instructions that follow before you use the product.

- High noise levels and long-term exposure to noise can cause noise-induced hearing loss.
- To keep the noise level to a minimum, do maintenance on and operate the product as given in the operator's manual.
- Examine the muffler for damages and defects. Make sure that the muffler is correctly attached to the product.
- Use approved hearing protection while you operate the product.
- Listen for warning signals and voices when you use hearing protection. Remove the hearing protection

when the product is stopped, unless hearing protection is necessary for the noise level in the work area.

Personal protective equipment



WARNING: Read the warning instructions that follow before you use the product.

- Always use approved personal protective equipment when you operate the product. Personal protective equipment cannot fully prevent injury but it decreases the degree of injury if an accident does occur. Let your dealer help you select the correct personal protective equipment.
- Regularly do a check of the condition of the personal protective equipment.
- Use an approved protective helmet.
- Use approved hearing protection.
- Use approved respiratory protection.
- Use approved eye protection with side protection. There is a high risk of eye injury from thrown objects.
- Use protective gloves.
- Use boots with steel toe-cap and non-slip sole.
- Use approved work clothing or equivalent close-fitting clothing that has long sleeves and long legs.

Fire extinguisher

- Keep a fire extinguisher near during operation.
- Use a powder fire extinguisher of "ABE" class or a carbon dioxide fire extinguisher of "BE" type.

Safety devices on the product



WARNING: Read the warning instructions that follow before you use the product.

- Do not use a product with defective safety devices.
- Do a check of the safety devices regularly. If the safety devices are defective, speak to your Husqvarna service agent.

Machine stop button

The machine stop button quickly stops the engine and all electrical functions but not the lights. The machine

stop button sets the product in safe mode. The product cannot start again until the safe mode is reset.

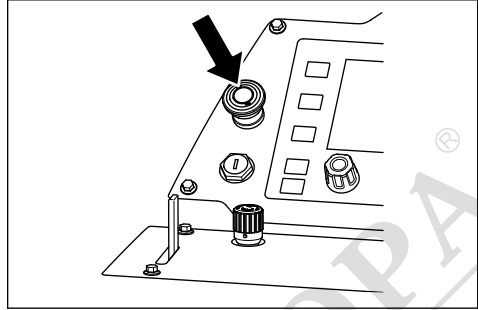

Note: Do not use the machine stop button to stop the product unless there is an emergency. For correct procedure how to stop the product during operation, refer to *To stop the product on page 25*.

To do a check of the machine stop button

1. Start the engine. Refer to *To start the product on page 21*.
2. Push the machine stop button. The engine stops and the product is set to safe mode.
3. Pull out the machine stop button to reset the machine stop.

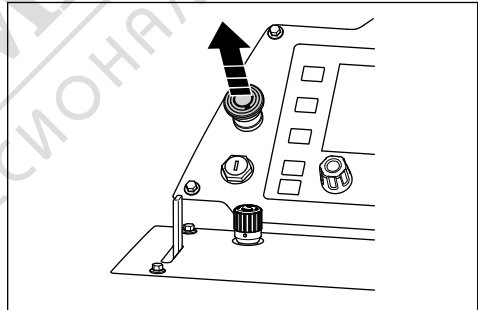

4. To reset the safe mode, turn the engine start switch to engine stop position (B) and then to ignition on position (A).

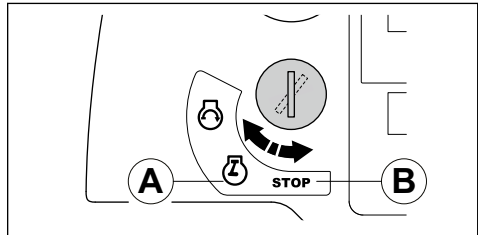

Blade guard

The blade guard is a protective cover for the top part of the cutting blade. It gives protection if parts from a damaged cutting blade or other objects eject in the direction of the operator. The blade guard prevents injury from the cutting blade. The blade guard is also a part of the water cooling system that keeps the cutting blade cool during operation.

To do a check of the blade guard

- Make sure that the blade guard is correctly installed. Refer to *To install a blade guard on page 17*.
- Examine the blade guard for damages, such as cracks.
- Replace a damaged blade guard.
- Replace the blade guard if it is hit, bent or has other defects.
- Examine the blade guard lock for damages.
- Make sure that the blade guard lock is correctly engaged.

Protective covers

Missing or damaged protective covers increase the risk of injury on moving parts and hot surfaces.

To do a check of the protective covers

- Do a check of the protective covers before you operate the product.

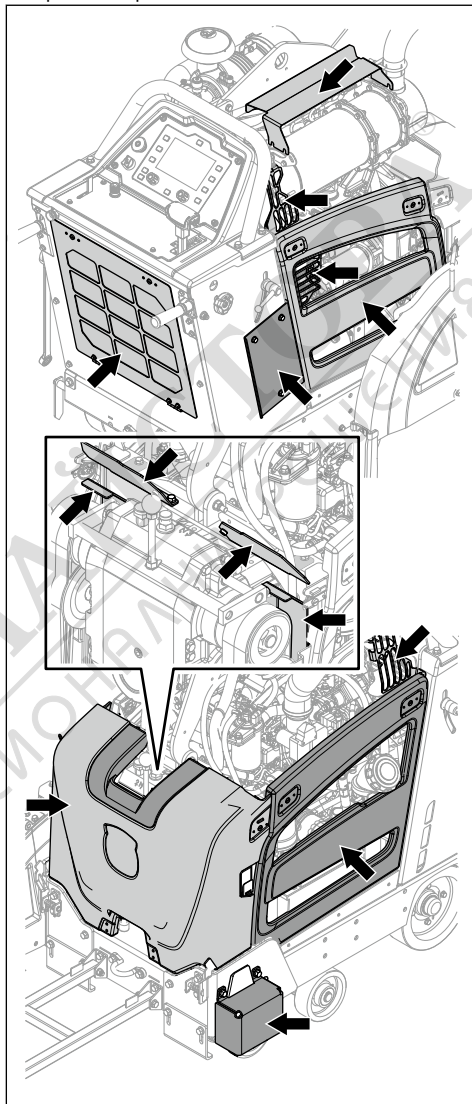

- Make sure that the protective covers are correctly attached and do not have cracks or other damages.
- Replace damaged protective covers.

Muffler

The muffler keeps the noise levels to a minimum and sends the exhaust fumes away from the operator.



Do not use the product if the muffler is missing or defective. A defective muffler increases the noise level and the risk of fire.



WARNING: The muffler becomes very hot during and after use and when the engine operates at idle speed. Be careful near flammable materials and/or fumes to prevent fire.

To do a check of the muffler

- Examine the muffler regularly to make sure that it is attached correctly and not damaged.



CAUTION: Do not change the muffler. The muffler is of DPF type and a part of emissions compliance.

Fuel safety



WARNING: Read the warning instructions that follow before you use the product.

- Fuel is flammable and the fumes are explosive. Be careful with fuel to prevent injury, fire and explosion.
- Do not breathe in the fuel fumes. The fuel fumes are poisonous and can cause injury. Make sure that the airflow is sufficient.
- Do not remove the fuel tank cap or fill the fuel tank when the engine is on.
- Let the engine become cool before you refuel.
- Do not fill fuel in an indoor area. Not sufficient airflow can cause injury or death because of asphyxiation or carbon monoxide.
- Do not smoke near the fuel or the engine.
- Do not put hot objects near the fuel or the engine.
- Do not fill fuel near sparks or flames.
- Before you refuel, open the fuel tank cap slowly and release the pressure carefully.
- Fuel on your skin can cause injury. If you get fuel on your skin, use soap and water to remove the fuel.
- If you spill fuel on your clothing, change clothing immediately.
- Do not fill the fuel tank fully. Heat causes the fuel to expand. Keep a space at the top of the fuel tank.
- Tighten the fuel tank cap fully. If the fuel tank cap is not tightened, there is a risk of fire.
- Before you start the product, move the product to a minimum of 3 m/10 ft from where you refueled.
- Do not start the product if there is fuel or engine oil on the product. Remove the unwanted fuel and engine oil and let the product dry before you start the engine.
- Examine the engine for leaks regularly. If there are leaks in the fuel system, do not start the engine until the leaks are repaired.

- Do not use your fingers to examine the engine for leaks.
- Keep fuel in approved containers only.
- When the product and fuel is in storage, make sure that fuel and fuel fumes cannot cause damage.
- Drain the fuel in an approved container outdoors and away from sparks and flames.

Battery safety



WARNING: A damaged battery can cause an explosion and cause injury. If the battery has a deformation or is damaged, speak to an approved Husqvarna service agent.



WARNING: Read the warning instructions that follow before you use the product.

- Use protective glasses when you are near batteries.
- Do not wear watches, jewelry or other metal objects near the battery.
- Keep the battery out of reach for children.
- Charge the battery in a space with good airflow.
- Keep flammable materials at a minimum clearance of 1 m when you charge the battery.
- Discard replaced batteries. See *Disposal on page 40*.
- Explosive gases can come from the battery. Do not smoke near the battery. Keep the battery away from open flames and sparks.

Safety instructions for maintenance



WARNING: Read the warning instructions that follow before you use the product.

- Use personal protective equipment. Refer to *Personal protective equipment on page 10*.
- If the maintenance is not done correctly and regularly, the risk of injury and damage to the product increases.
- Stop the engine and let the product become cool before you do the maintenance.
- Clean the product to remove dangerous material before you do the maintenance.
- Disconnect the spark plug cap before you do the maintenance.
- The exhaust fumes from the engine are hot and can contain sparks. Do not operate the product in indoor areas or near flammable material.
- Do not change the product. Modifications that are not approved by the manufacturer, can cause serious injury or death.
- Always use original accessories and spare parts. Accessories and spare parts that are not approved

by the manufacturer, can cause serious injury or death.

- Replace damaged, worn or broken parts.
- Only do the maintenance as given in this operator's manual. Let an approved service center do all other servicing.

- Remove all tools from the product before you start the engine after maintenance. Loose tools or tools attached to rotating parts can eject and cause injury.
- Let an approved service center do servicing on the product regularly.

Operation

Introduction



WARNING: Read and understand the safety chapter before you use the product.

To do before you operate the product

- Read this operator's manual carefully and make sure that you understand the instructions.
- Read the operator's manual for the control panel carefully and make sure that you understand the instructions.
- Read the engine manual that is supplied by the engine manufacturer.
- Read the instructions that are supplied with the cutting blade by the cutting blade manufacturer.
- Before you start the product for the first time, do these steps:

- a) Install a new battery and connect the battery cables. Refer to *To connect and disconnect the battery on page 35*.

Note: For some markets, the battery is installed when you purchase the product.

- b) Set the correct language and do other necessary settings on the control panel. Refer to the operator's manual for the control panel.
- Before each operation of the product, do these steps:
 - a) Do the daily maintenance. Refer to *Maintenance schedule on page 25*.
 - b) Make line marks for all cuts. Prepare the operation sequence carefully to prevent injury and damage.
 - c) Adjust the operation handles to an applicable operation position. Refer to *To adjust the position of the operation handles on page 14*.

- d) Lower the adjustable pointer and make sure that it aligns with the rear pointer, the cutting blade and the line mark on the surface. Refer to *To do a check of the pointers on page 13* if the pointers and the cutting blade do not align.

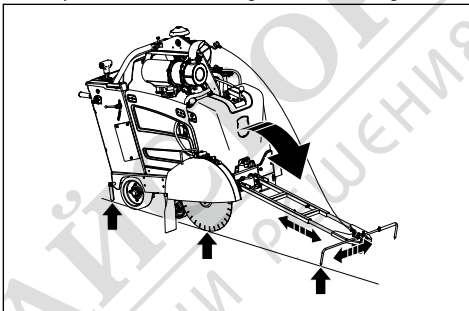

- e) If it is necessary, adjust the length of the adjustable pointer with the screws on the adjustable pointer.

To do a check of the pointers

1. Put a long straight metal bar or equivalent flat against the cutting blade.

Note: As an alternative to a straight metal bar, you can use the cord for the adjustable pointer. Attach the cord to the rear pointer and hold it along the side of the product, against the cutting blade.

2. Make sure that the rear pointer, the cutting blade and the adjustable pointer align.
 - a) Adjust the adjustable pointer with the screws.
 - b) To adjust the rear pointer, tap it with a mallet.

Cutting blades



WARNING: Do not use a cutting blade for other materials than which it is made for.



WARNING: Only use diamond blades for wet cutting. The diamond blade must be applicable to the same speed or a higher speed than the value given on the product type plate. Only use diamond blades that are in compliance with national or regional

standards, for example EN13236 or ANSI B7.1.

The cutting blade manufacturer gives warnings and recommendations for the operation and correct maintenance of the cutting blade. Those warnings are supplied with the cutting blade.

Diamond blades



WARNING: Make sure that the diamond blade rotates in the direction of the arrows shown on the diamond blade.

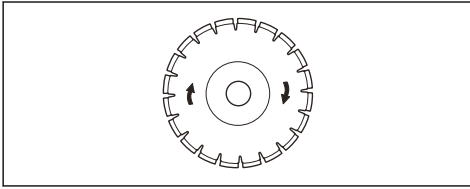

CAUTION: Always use a sharp diamond blade.

There is a wide range of diamond blades that is used for different operations. From new made concrete to concrete and asphalt that has become hard and for different hardness classes.

Diamond blades has a steel core with segments that are made of industrial diamonds.

Water cooling system

Always use water during operation to keep the temperature of the diamond blades down. The water cooling system also increases the lifetime of the diamond blades and prevents dust buildup.

Make sure that the water supply is not clogged.

To sharpen the diamond blades

Diamond blades can become blunt if you use an incorrect feeding pressure or when you cut materials such as hard reinforced concrete. If you use a blunt diamond blade it becomes too hot, which can cause the diamond segments to come loose.

- Decrease the cutting depth and the engine speed for a short time to sharpen the diamonds on the diamond blade.

Diamond blades for wet cutting



CAUTION: Always use a blade flange dimension that is specified for the current blade dimension. Do not use blade flanges that are damaged.

During the operation, the friction causes the diamond blade to become very hot. If the diamond blade becomes too hot, it will decrease the blade tension or make the core crack.

Let the diamond blade become cool before you touch it.

- Diamond blades for wet cutting must be used with water to keep the diamond blade core and segments cool during cutting. Diamond blades for wet cutting can not be used dry.
- If you use diamond blades for wet cutting without water, the diamond blade can become too hot. This gives bad performance, blade damage and is a safety risk.

To fill fuel



CAUTION: Always use correct fuel type. Incorrect fuel type causes damage to the product.



CAUTION: Do not use biodiesel. Biodiesel causes damage to the fuel hoses.

- Use diesel fuel of the correct type. Refer to *Technical data on page 41*. For more information about the fuel, refer to the engine manual supplied by the engine manufacturer.

To adjust the position of the operation handles

1. To adjust the length of the operation handles, loosen the locking knob (A).

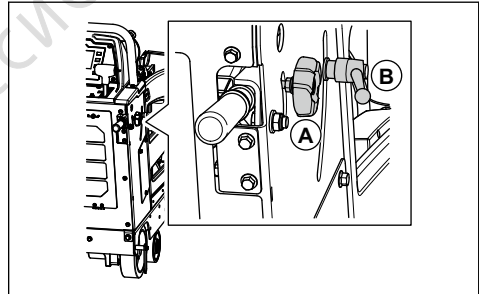

2. Adjust the operation handles to applicable operation length.
3. Tighten the locking knob (A).
4. To adjust the height of the operation handles, turn the locking knob (B) counterclockwise.
5. Adjust the operation handles to applicable operation height.
6. Turn the locking knob (B) clockwise to lock the operation handles in position.

To install a cutting blade

Read the section *Product configuration for different blade dimensions on page 17* before you install a cutting blade.

1. Set the engine start switch to ignition on position (A).

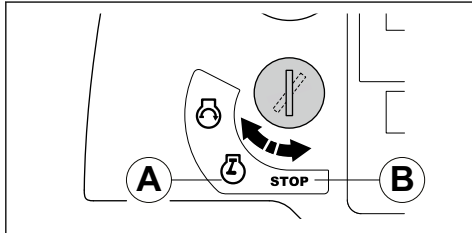

2. Push the switch for cutting depth adjustment up to lift the cutting blade.

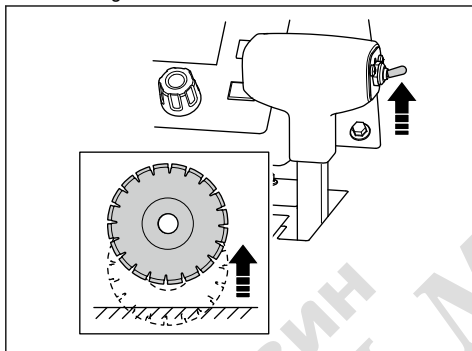

3. Set the engine start switch to stop position (B).
4. Push the machine stop button on the control panel.

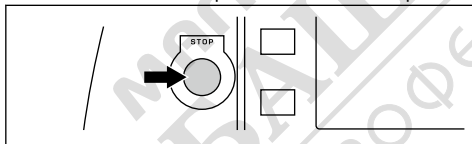

5. Close the water valve.

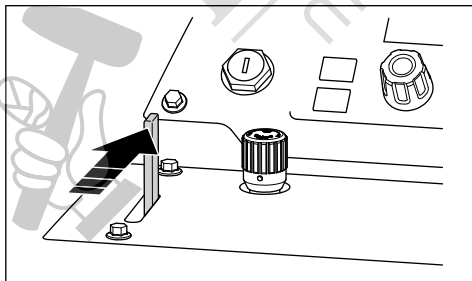

6. Loosen the front bolt on the blade guard and lift the blade guard latch (A).

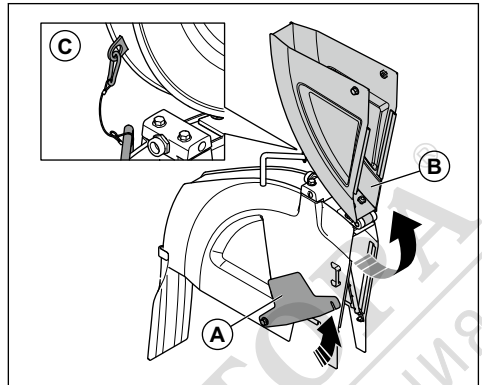

7. Lift the blade guard front (B) and lock the blade guard in upright position with a wire and carabiner (C).
8. Remove the blade shaft bolt (A).

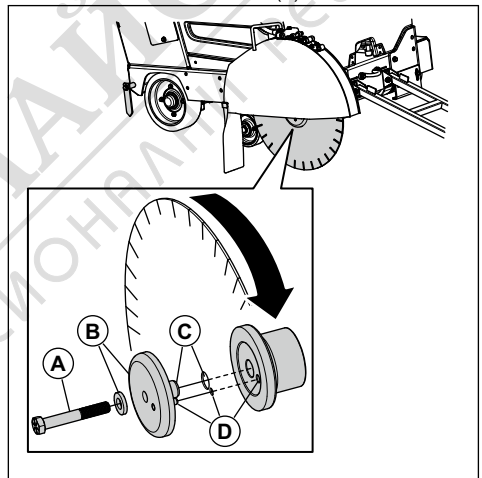

Note: The blade shaft bolt on the right side of the product has a left thread. The blade shaft bolt on the left side of the product has a right thread.

9. Remove the outer blade flange and the flat washer (B).
10. Examine the blade shaft bolt, the blade flanges, the flat washer and the blade flange arbor (C) for damages. Replace worn or damaged parts.
11. Clean the contact surfaces of the cutting blade and the blade flanges.
12. Put the cutting blade on the outer flange arbor.
13. Install the cutting blade and the outer flange into the inner flange. Make sure that the locking pin (D) goes through the blade and into the inner flange.

14. Make sure that the cutting blade rotates in the direction of the arrows shown on the cutting blade.

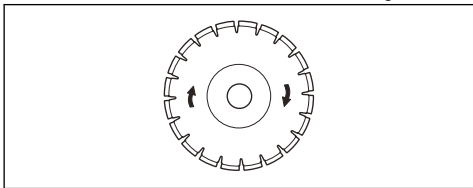

CAUTION: Risk of damage to the cutting blade if it is installed opposite the direction of rotation.

15. Install the flat washer and the blade shaft bolt.
16. To remove play, turn the outer flange and the cutting blade in the opposite direction of which the cutting blade rotates.

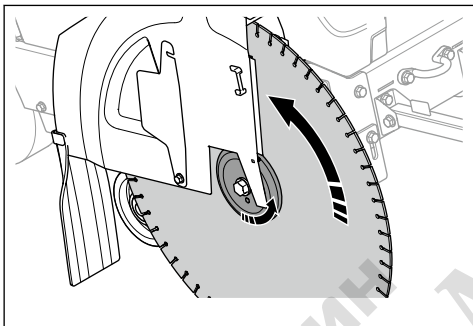

17. Hold the cutting blade tightly while you tighten blade shaft bolt with the blade shaft wrench.
18. Push the switch for cutting depth adjustment down to lower the cutting blade until it touches the surface.

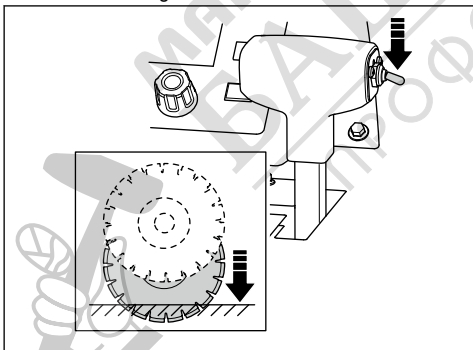

CAUTION: Do not lower the cutting blade too quickly. If the cutting blade hits the surface with force, the cutting blade can become damaged. Decrease the speed with the knob for adjustment of the blade lowering speed.



CAUTION: Do not let the front weight of the product push down on the cutting blade. This causes damage to the cutting blade.

19. Tighten the blade shaft bolt fully with the blade shaft wrench. The resistance between the cutting blade and the ground keeps the cutting blade in position.
20. Lower the blade guard front and put the blade guard latch on the front bolt of the blade guard. Tighten the front bolt of the blade guard.

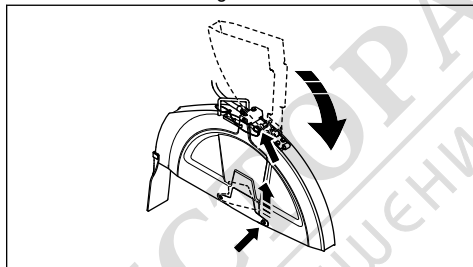

CAUTION: Do not operate the product without the blade guard latch engaged and the front bolt of the blade guard installed. Do not use the product if the parts are damaged.

21. Start the product and listen for unusual sounds. If there are unusual sounds, remove the cutting blade.
a) Examine the cutting blade for damages.
b) Install the cutting blade again. Replace the cutting blade if it is damaged.

To remove the cutting blade



WARNING: When you remove diamond blades, let the product become cool and use protective gloves. Diamond blades are very hot after use.

- Remove the cutting blade in the opposite sequence of how it was installed. Refer to *To install a cutting blade on page 15*.

To install a blade guard

1. Lower the blade guard onto the supports (A), (B), and (C).

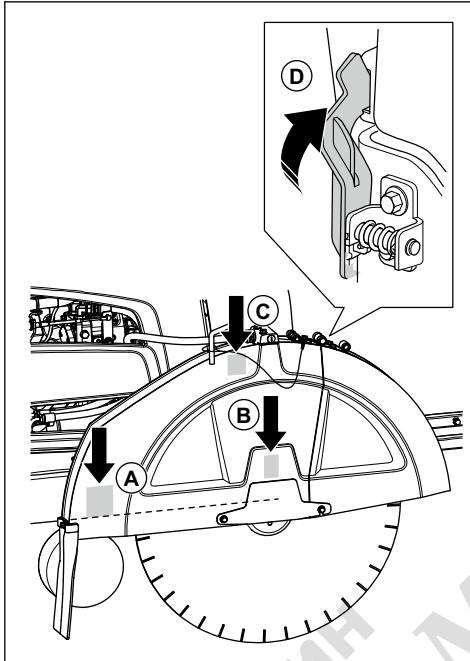

2. Push the blade guard down until the blade guard lock (D) engages.
 3. Connect the water hose.
- All supports are not used for all blade guard dimensions.

- 14 in., 20 in. and 26 in. blade guards are lowered onto the support (B) only.
- 30 in. blade guard is lowered onto the supports (B) and (C).
- 36 in. blade guard is lowered onto all supports (A), (B), and (C).

To remove the blade guard

1. Disconnect the water hose (A) from the blade guard.

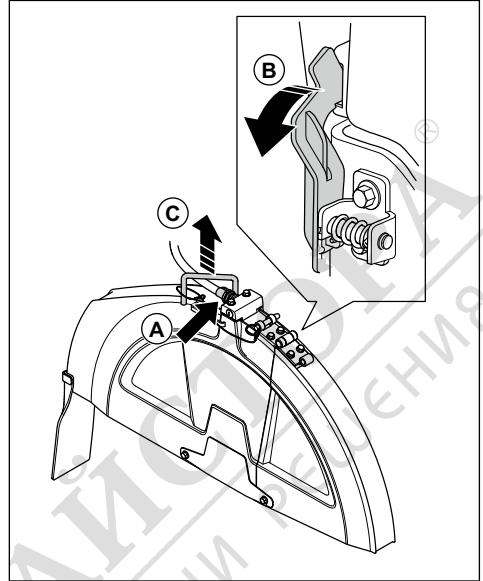

2. Use the blade shaft wrench to turn the blade guard lock (B) forward until it stops and disengages.
3. Lift the blade guard at the handle (C).

Product configuration for different blade dimensions

A product with a 1-speed gearbox operates with 1 specified blade dimension and 1 specified blade guard. A product with a 3-speed gearbox operates with a specified range of blade dimensions in 1 specified blade guard. If you replace the cutting blade with a cutting blade of a different dimension, it is necessary to change the configuration of the product.

For a product with a 1-speed gearbox, replace these parts with parts of the applicable dimension for the new cutting blade:

- Blade shaft pulleys
- Gearbox pulleys
- Blade shaft flanges
- Belts
- Blade guard

For a product with a 3-speed gearbox it is sufficient to change the gear if the dimension of the new cutting blade is in the same dimension range as the replaced cutting blade. If the dimension range is different, it is necessary to replace the parts in the list also on a product with a 3-speed gearbox.

Let your dealer help you to send an order for the parts that is necessary for your configuration.

To do a configuration of the gearbox

- To change gearbox setup on the control panel display, refer to the operator's manual for the control panel.

Configuration of a 1-speed gearbox model

There are 5 possible configurations for a 1-speed gearbox product:

mm/in.
350/14
500/20
650/26
750/30
900/36

Refer to the operator's manual for the control panel for more information.

Configuration of a 3-speed gearbox model

There are 3 possible configurations for a 3-speed gearbox product:

mm/in.
350–650/14–26
500–750/20–30
500–900/20–36

Refer to the operator's manual for the control panel for more information.

To change gears on a 3-speed gearbox model



CAUTION: Do not change gears when the engine is on or before you do a check of the product configuration. There is a risk of damage to the gearbox.

The gearbox has 3 speed positions and 2 neutral positions available. When the gearbox is set to neutral

position, the cutting blade does not rotate when the engine is on.

- Turn the engine start switch to the stop position.
- Make sure that the dimension of the gearbox pulleys, blade shaft pulleys and blade shaft flanges are correct for the dimension of the installed cutting blade.
- Make sure that the blade shaft speed is correct. 
- Turn the knob (A) 2 revolutions counterclockwise to loosen the locknut.

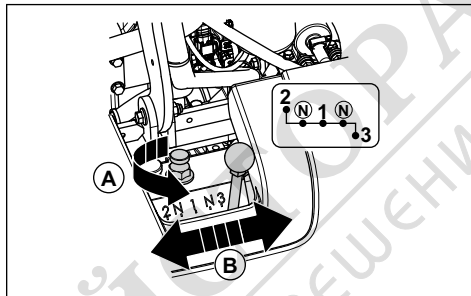

- Loosen the locknut fully but do not remove it.
- Move the gearshift lever (B) to the applicable gear. If it is not easy to move the gearshift lever, turn the blade shaft a small distance.
- Tighten the knob clockwise with your fingers.

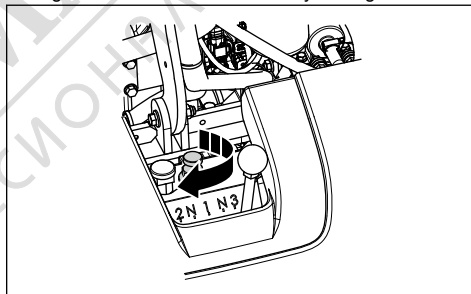

- Tighten the locknut with the supplied blade shaft wrench. Refer to *Product overview, rear on page 4*.

Change of blade dimension, 1-speed gearbox model

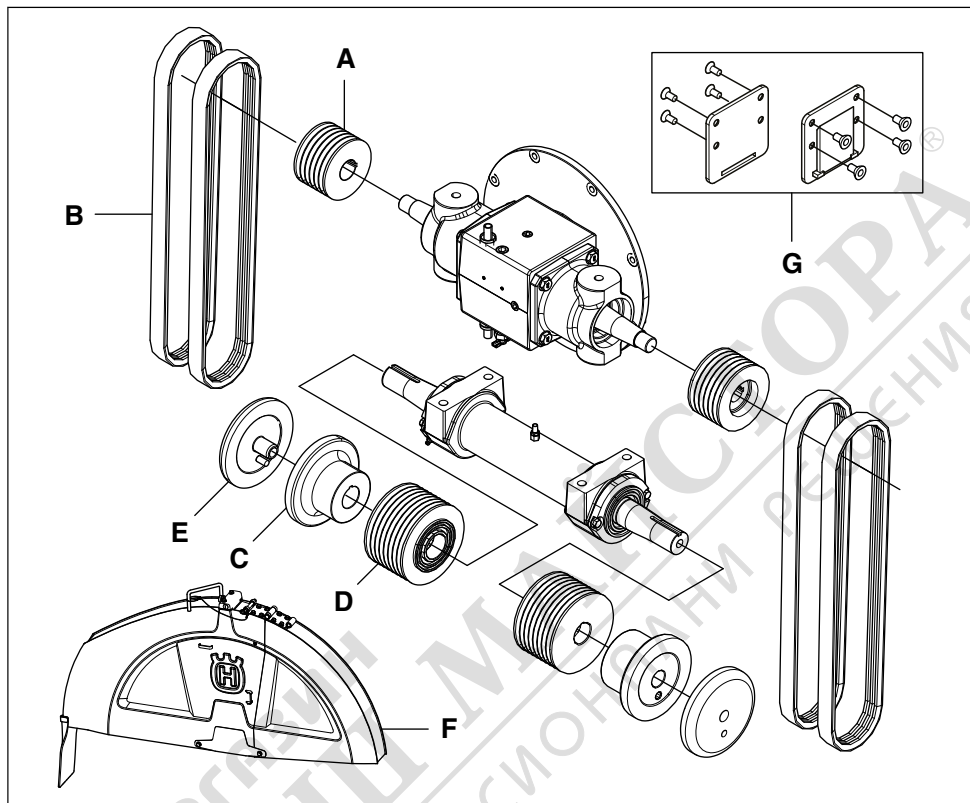

* = The part is included in the initial configuration of the product. Parts that are not in this table are also included in the initial configuration of the product.

Dimension, mm/in.	A	B	C	D	E	F	G
350/14	15.25/6	3VX475	114/4.5	106/4.17	114/4.5	350/14	No
500/20	114/4.51	3VX450	114/4.5	106/4.17	114/4.5	500/20	No
650/26	89/3.5	3VX435	127/5	106/4.17	127/5	650/26	No
750/30	89/3.5	3VX450	127/5	121.5/4.78	127/5	750/30	No
900/36	89/3.5	3VX460	152.5/6	146/5.75	152.5/6	900/36	Yes

Change of blade dimension, 3-speed gearbox model

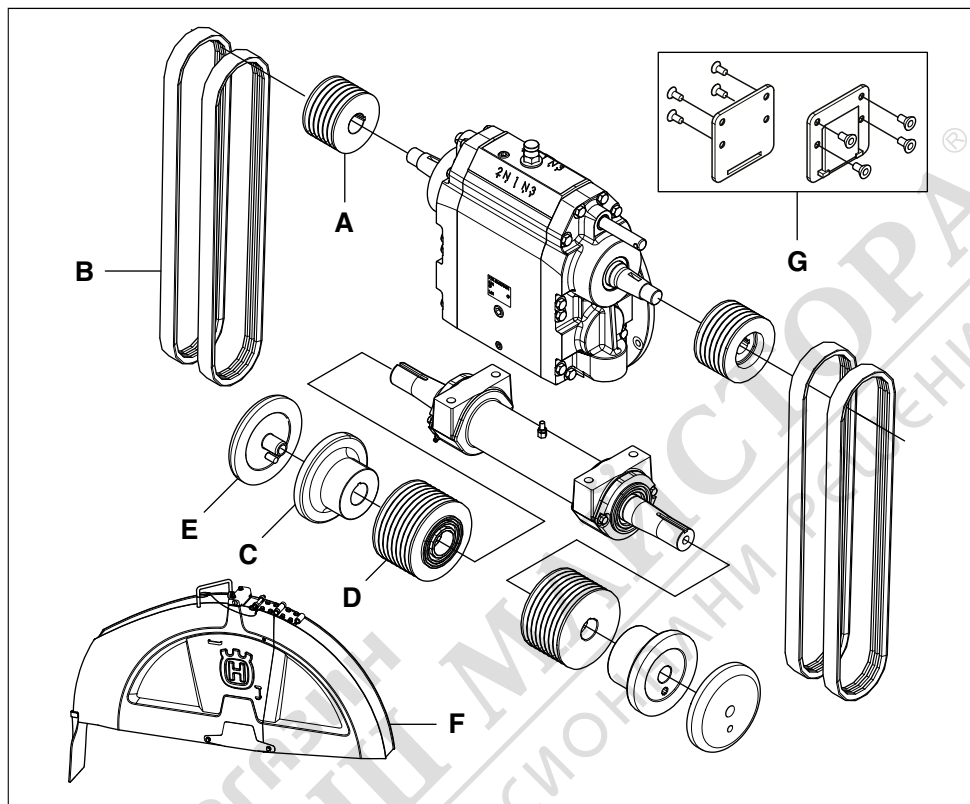

* = The part is included in the initial configuration of the product. Parts that are not in this table are also included in the initial configuration of the product.

Dimension, mm/in.	A	B	C	D	E	F	G
350-650/14-26	114/4.51	3VX550	127/5	106/4.17	127/5	350-650/14-26	No
500-750/20-30	105/4.13	3VX550	127/5	115/4.53	127/5	500-750/20-30	No
500-900/20-36	105/4.13	3VX560	152.5/6	138/4.53	152.5/6	500-900/20-36	Yes

Blade depth stop

The product has the function blade depth stop that lets the operator set the maximum cutting depth. The maximum cutting depth is different for different blade dimensions:

Dimension, mm/in.	Max. cutting depth, mm/in.
350/14	118/4.75

Dimension, mm/in.	Max. cutting depth, mm/in.
500/20	193/7.75
650/26	262/10.5
750/30	312/12.5
900/36	374/15

To set the cutting depth

1. Push the switch for cutting depth adjustment down to lower the cutting blade until it touches the surface. This is the start position for the cutting depth.

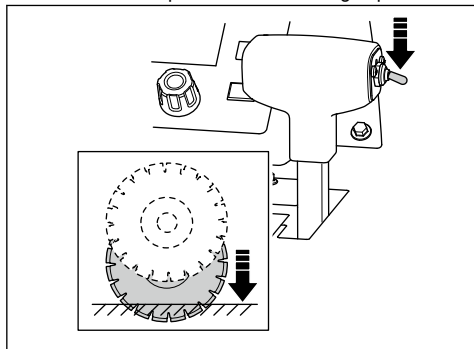

CAUTION: Do not lower the cutting blade too quickly. If the cutting blade hits the surface with force, it can cause damage to the cutting blade. Decrease the speed with the knob for adjustment of the blade lowering speed.

2. Push the reset button for the blade depth stop on the control panel. The cutting depth value is set to 0 in./mm on the display.

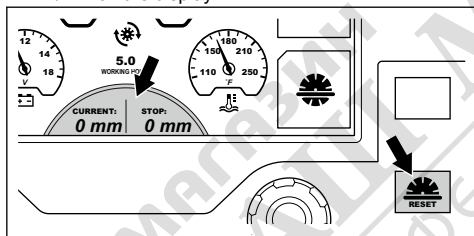

3. Push the button adjacent to the symbol for blade depth stop. The symbol on the display changes color to show that the function is engaged.

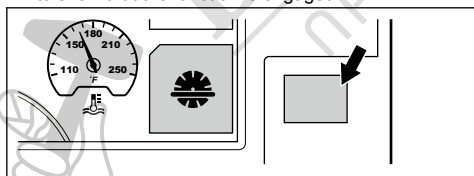

4. Turn the knob for adjustment of the blade depth stop until the correct cutting depth shows on the display. During operation, the cutting blade is not lowered more than the set cutting depth.

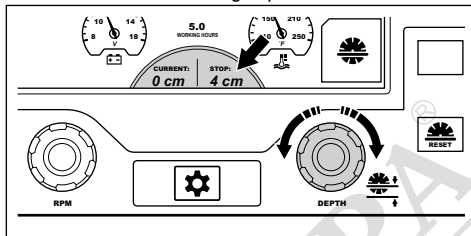

CAUTION: Always do a check that the cutting depth is correct. The blade depth stop helps you to get the correct cutting depth but only gives an indication of the depth value.

5. If it is necessary to increase the cutting depth, do 1 of these procedures:
 - a) Turn the knob for adjustment of the blade depth stop to set a new cutting depth.
 - b) Push the button adjacent to the symbol for blade depth stop to disengage the function. The symbol on the display changes color to show that the function is disengaged.

To start the product

1. Connect the water inlet to a water supply.
2. Close the water valve.

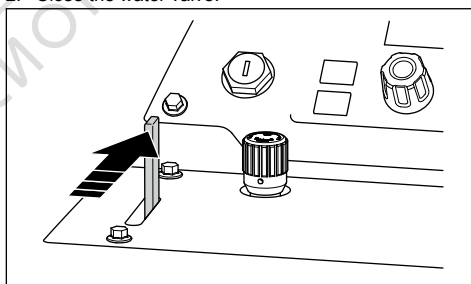

3. Set the lever for speed control to the stop position.

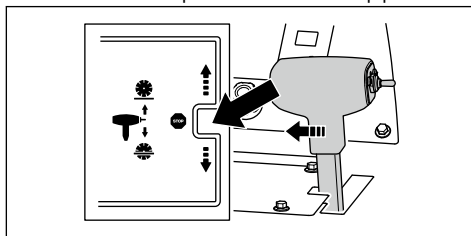

4. Make sure that the transmission bypass valve is closed. Refer to *Product overview, left side on page 2* for the position of the transmission bypass valve.

- Turn the engine start switch to ignition on position (A).

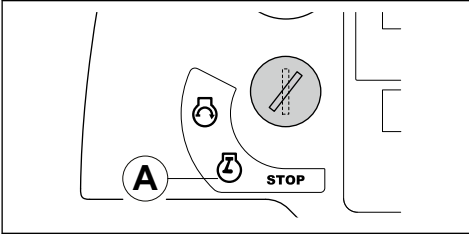

- If the preheating symbol shows on the display, wait until it goes off. Refer to *Warning symbols on the control panel display on page 7*.
- Turn the engine start switch to engine start position (B). The engine starts.

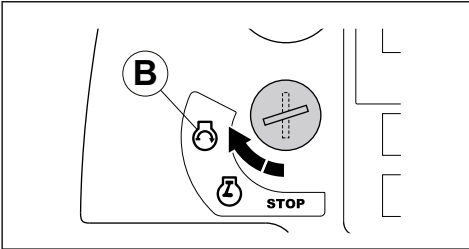

- Let the engine operate at idle speed for 2-3 minutes until the temperature gauge starts to move.



CAUTION: Do not let the engine operate at low idle speed when the product is not in operation. Low idle speed increases the quantity of particles in the engine and decreases the time between regenerations.



WARNING: For products without a blade clutch, the cutting blade starts to rotate when the engine starts and the gear is not in neutral. Do not move the product to the side or out of the work area if the cutting blade rotates.

To operate the product

- Start the engine.



- Push the button adjacent to the symbol for the water safety system. The symbol on the display changes color to show that the function is engaged.

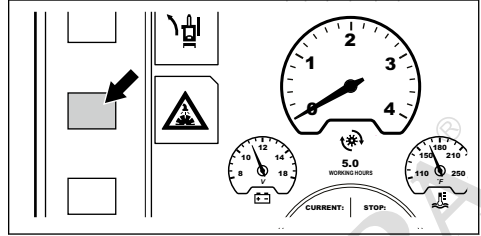

- Open the water valve.

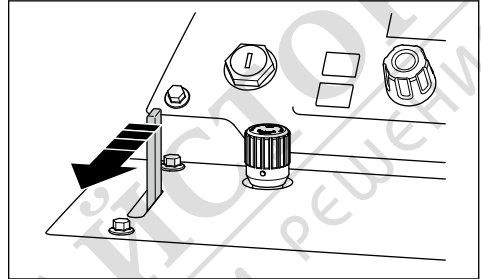

- Push the engine speed button (A). The engine symbol (C) shows that the speed adjustment knob (B) adjusts the engine speed.

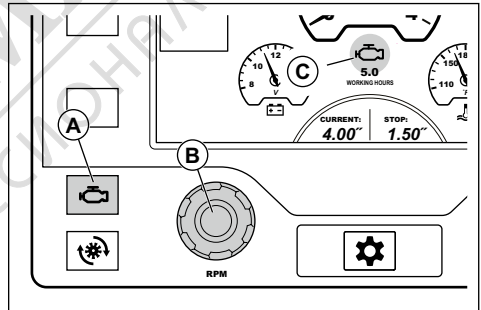

- If the product has a blade clutch, do this procedure:
 - Make sure that the engine speed is not higher than 1200 rpm.

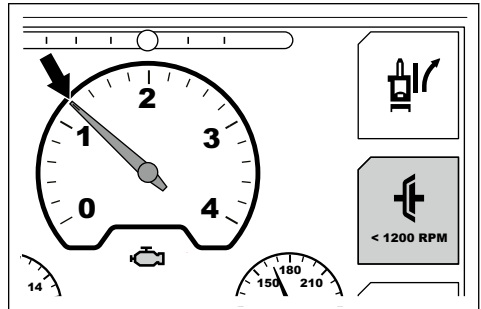

- b) Push the button adjacent to the blade clutch symbol on the display. The symbol on the display changes color to show that the drive on the cutting blade is engaged.

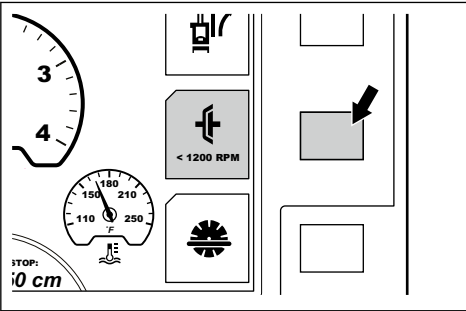

6. Turn the speed adjustment knob clockwise to increase the engine speed to full throttle.
7. To set the blade lowering speed, turn the knob for adjustment of the blade lowering speed. Turn counterclockwise to increase the speed and clockwise to decrease the speed.

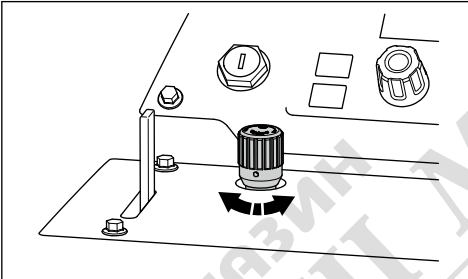

8. Keep the adjustable pointer, the rear pointer and the cutting blade on the line mark during the full operation.
9. Push the switch for cutting depth adjustment down to lower the cutting blade to the correct cutting depth. Refer to *Blade depth stop* on page 20.

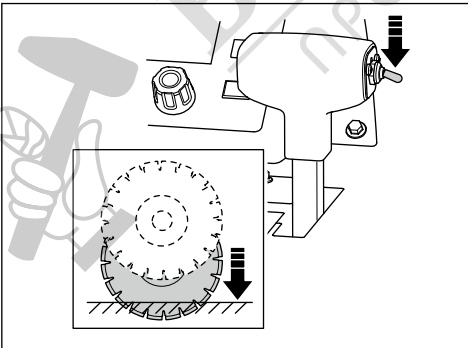

CAUTION: If you lower the cutting blade into a cut that is not fully completed, align the cutting blade accurately with the cut to prevent damage to the cutting blade.

10. Push the lever for speed control forward slowly to move the product forward.
11. Listen to the sound of the engine. Pull the lever for speed control rearward to adapt the forward speed to the sawing conditions.
12. When the operation is completed, set the lever for speed control in the stop position.

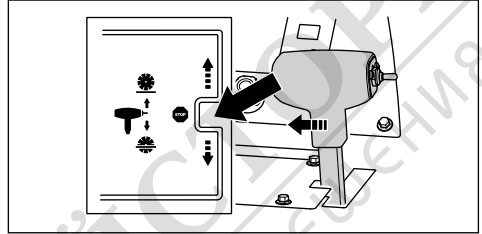

13. Push the switch for cutting depth adjustment up until the cutting blade is above the surface.

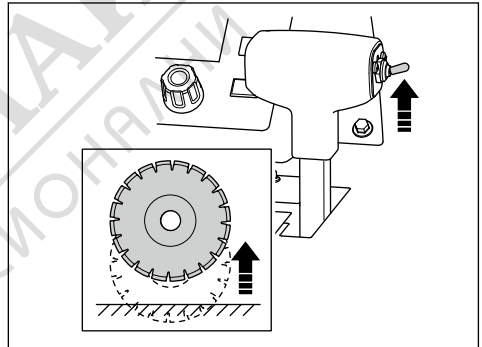

14. Turn the knob for the throttle control to the low idle position.

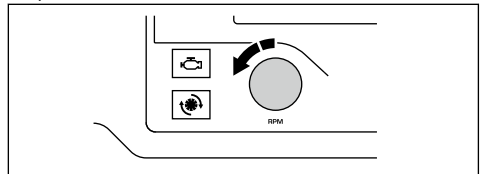

15. If the product has a blade clutch, push the button adjacent to the blade clutch symbol on the display. The symbol on the display changes color to show that the drive on the cutting blade is disengaged.

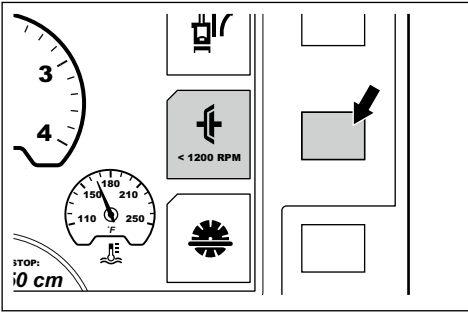

Note: Refer to *Straight operation of the product* on page 24 for information about how to adjust the rear axle if the product does not cut straight.

To use the correct working technique

- Stay away from the blade path while the engine is on. The correct operator position is between the handles.

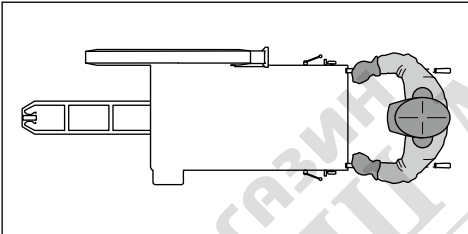

- Examine the cutting blade frequently for cracks and broken parts during the work day. Do not use a damaged cutting blade.



WARNING: Stop the engine before you examine the cutting blade.

- Do not grind with the side of the cutting blade. The cutting blade can break and cause injury to the operator or bystanders. Only use the cutting edge.
- Do not bend or twist the cutting blade in the cut.
- Make sure that the cutting blade moves freely and does not catch in the cut.

Straight operation of the product

During operation, the cutting blade causes resistance to the forward movement from the rear wheels. This causes the product to steer in the same direction as the cutting blade is installed. To prevent a bent cut, the angle of the rear axle can be adjusted. There are 2 procedures to adjust the rear axle, with the E-track function or with a manual axle adjustment.

To adjust the rear axle with the E-track function

You can do the rear axle adjustment with the E-track function during operation or when the product is stationary.

- Push the left and right E-track adjustment buttons (A) to adjust the rear axle. Push again and again for small adjustments.

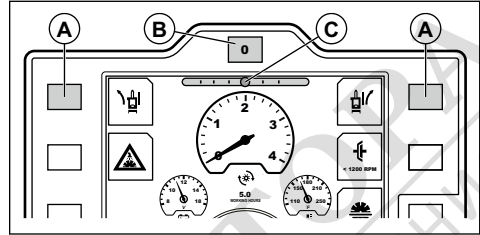

Note: The E-track gauge (C) on the display shows the current angle of the rear axle. The adjustment is saved when the ignition is off or if the product becomes without power.

- Look at the movement and the direction of the product to make sure that the adjustment is correct.
- To reset the rear axle to the center angle that is set in the system, push the E-track reset button (B).
- To go back to the adjusted angle, push the E-track reset button again.
- To adjust the center angle that is set in the system, refer to the operator's manual for the control panel.

To adjust the rear axle manually

- Turn the adjustment bolt at the lower left at the rear of the product. Use an 18 mm wrench.

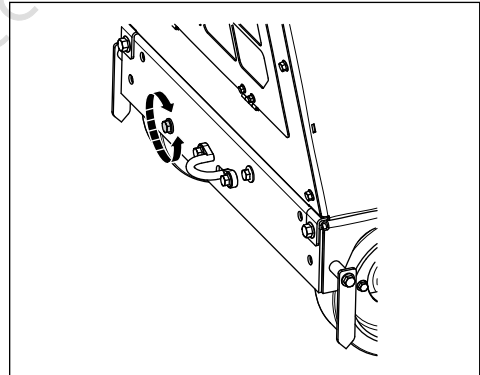

- If the product steers to the right during operation, turn the adjustment bolt counterclockwise.
- If the product steers to the left during operation, turn the adjustment bolt clockwise.

To stop the product

1. Turn the knob for the throttle control to the low idle position.

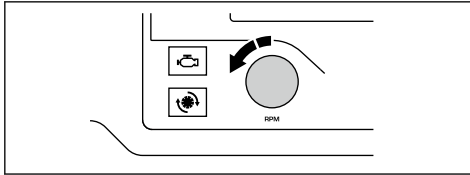

2. Close the water valve.

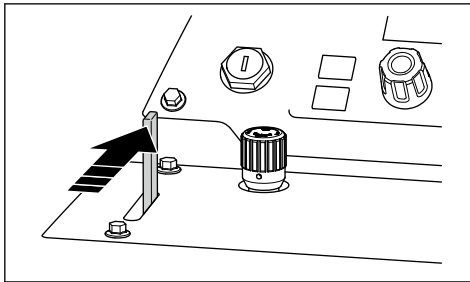

3. Let the engine operate at idle speed for 2-3 minutes.
4. Turn the engine start switch to the stop position (A).

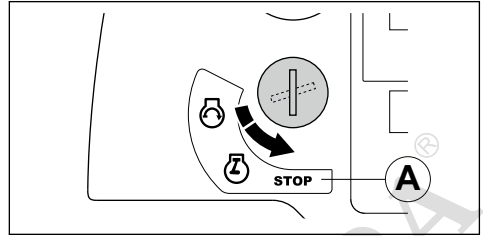

WARNING: The cutting blade continues to rotate for a while after the engine stops. Do not stop the cutting blade with your hands. Serious injuries can occur.

Maintenance

Introduction



WARNING: Read and understand the safety chapter before you do maintenance on the product.

For all servicing and repair work on the product, special training is necessary. We guarantee that professional repairs and servicing is available. If your dealer is not a service agent, speak to them for information about the nearest service agent.

For spare parts, speak to your Husqvarna dealer or service agent.

To do before the maintenance

- Park the product on a level surface and stop the engine. Push the machine stop button on the control panel to prevent accidental start during maintenance.

- Clean the area around the product from oil and dirt. Remove unwanted objects.
- Put clear signs around the maintenance area to give a warning to bystanders that maintenance work is in progress.
- Keep fire extinguishers, medical supplies and an emergency phone near.

Maintenance schedule

Note: If more than 1 time interval is identified in a table row, the shortest time interval is for the first maintenance only.

* Refer to *Safety devices on the product on page 10* for instructions.

Maintenance	Daily and after transportation	50 h	100 h	250 h	500 h	Yearly
Clean the product.	X					
Do a check of the radiator coolant level.	X					
Do a check of the engine oil level.	X					

Maintenance	Daily and after transportation	50 h	100 h	250 h	500 h	Yearly
Do a check of the blade guard.	*					
Examine all hoses and hose clamps. Look for damage where the hoses rub against other hoses or parts of the product.	X					⊕
Clean the outer air filter.	X					
Do a check of the protective covers and blade guards.	*					
Drain water from the gearbox.	X					
Do a check of the water supply to the cutting blade.	X					
Drain the water separator for the fuel filter.	X					
Replace the engine oil and engine oil filter.		X	X			
Clean the radiator air filter.		X				
Do a check of the V-belts.		X				
Lubricate the front wheels.		X				
Replace the hydraulic system filter.		X		X		
Lubricate the pivot bearings of the front axle.			X			
Examine the wheels and wheel hubs for damage and make sure that they are installed correctly.			X			
Examine the air filter hose and hose clamps.			X			
Do a check of the hydraulic oil level.			X			
Lubricate the blade shaft.				X		
Lubricate the pivot on the hydraulic cylinder.	X					
Lubricate the rear axle bearing.				X		
Replace the hydraulic oil.					X	
Replace the oil in the gearbox.					X	
Replace the fuel filter.					X	
Replace the radiator coolant.					X	
Replace the air filters.						X
Do a check that the coolant mixture is correct. Refer to <i>Technical data on page 41.</i>						X

To clean the product



WARNING: Use protective glasses. When you clean with a high-pressure washer, dirt and harmful material can eject from the product.

- Make sure that the cover for the relay and fuse box is correctly installed before you clean the product.
- Do not clean electrical components with water.
- Use a weak cleaning agent. Put on protective gloves to prevent skin irritation.
- Use a high-pressure washer to clean the product.

- Let the product become cool before you clean it.

To clean the radiator



CAUTION: Obey the instructions. Incorrect procedure can cause damage to the cooling fins.

- Use compressed air to clean the cooling fins.
- If it is necessary, use a high-pressure washer and a weak cleaning agent.
- Spray directly on the radiator, in parallel to the cooling fins.
- Keep a minimum distance of 40 cm/15.75 in. between the cooling fins and the nozzle for the high-pressure washer or air flow.

To clean the control panel



CAUTION: Do not use a high-pressure washer to clean the control panel.

- Clean electrical components with a cloth or with compressed air.
- Clean the control panel with a moist cloth.

To clean the engine

- Keep a minimum distance of 40 cm/15.75 in. between the nozzle and the engine and engine components.
- Be careful when you clean the engine, especially near electrical components. Do not spray water directly at electrical components.
- Do not point the water directly into the exhaust pipe or the engine air filter.

To do after you clean the product

- Blow electrical terminals dry with compressed air.
- Let the product become fully dry before you start the engine.

To do a check of the radiator coolant level



WARNING: Risk of burn injuries. Let the engine become cool before you open the radiator coolant lid.

1. Examine the radiator coolant level at the container for radiator coolant spill. The coolant level is correct when it is between the 2 marks.

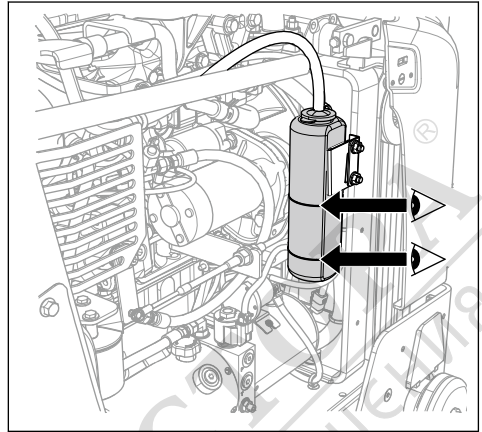

2. If the radiator coolant level is too low, remove the lid and fill until the level is correct. Refer to *Technical data on page 41* for correct radiator coolant type and mixture.

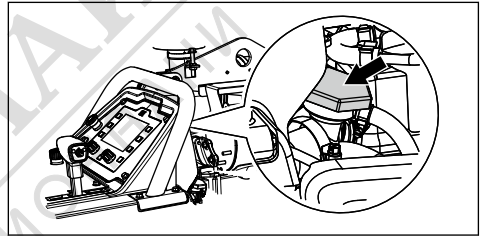

To do a check of the engine oil level

To read the oil level correctly the product must be in the correct position.

1. Make sure that the cutting blade is removed and that the product is level when you examine the engine oil level.
2. Remove the dipstick from the oil tank.

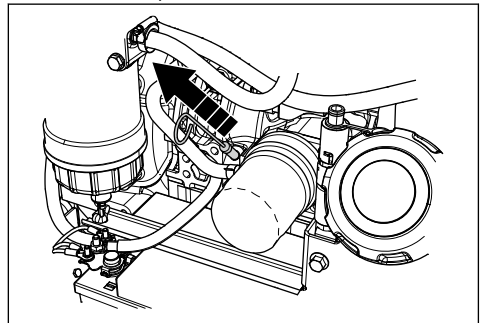

3. Clean the oil from the dipstick.

4. Put the dipstick back fully into the oil tank.
5. Remove the dipstick.
6. Examine the oil level on the dipstick. Make sure that the level of engine oil is between the marks on the dipstick.

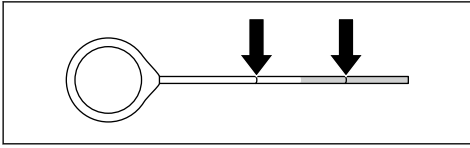

7. If the oil level is low, fill with engine oil and do a check of the oil level again. Refer to *Technical data on page 41* for correct engine oil type.

To examine hoses and hose clamps

- Look for leakage on the hoses in the fuel system, the hydraulic system and the cooling system.
- Examine the hoses for wear and damage, especially where the hoses rub against other hoses or parts of the product.
- Replace damaged hoses.
- Tighten loose hose clamps.

To clean the outer air filter



WARNING: Use approved respiratory protection when you clean or replace the air filter. Discard used air filters correctly. The dust in the air filter is dangerous to your health.



WARNING: Do not clean the air filter with compressed air. This causes damage to the air filter and the risk increases that you breathe the dangerous dust.

It is not necessary to clean the inner air filter.

1. Examine the air filter indicator (A). If the air filter indicator is red, it is necessary to clean the outer air filter.
2. Open the 3 clamps of the air filter housing and remove the air filter housing.

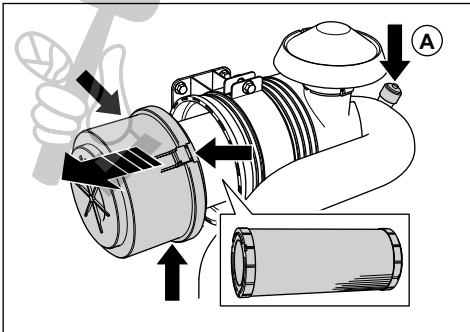

3. Remove the air filter.
4. Tap the air filter against a hard surface or use a vacuum cleaner to remove the particles.



CAUTION: Do not let the nozzle of the vacuum cleaner touch the surface of the air filter. Keep a small distance. The sensitive surface of the air filter becomes damaged if objects touch it.

5. Replace damaged gaskets.
6. Examine the air filter hose and the hose clamps.
 - a) Replace damaged parts.
 - b) Tighten loose clamps.
7. Install the outer air filter.
8. Install the air filter housing and close the 3 clamps of the air filter housing.

Note: If the 3 clamps of the air filter housing cannot be closed, the outer air filter is not correctly installed.



CAUTION: Always replace a damaged air filter, or the dust will go into the engine and cause engine damage. Damage to the engine because of a damaged air filter voids the warranty.

To drain water from the gearbox



CAUTION: Water in the gearbox can cause corrosion and freeze damages.

1. Turn the water drain valve on the gearbox counterclockwise to open.

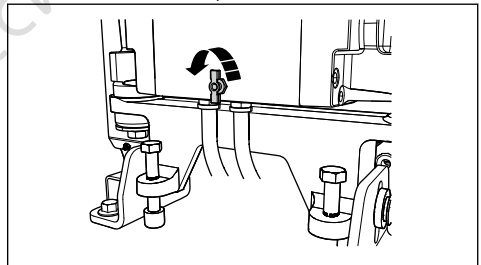

2. Turn the water drain valve on the gearbox clockwise to close.

To do a check of the water supply to the cutting blade

1. Loosen the front bolt on the blade guard and lift the blade guard latch (A).

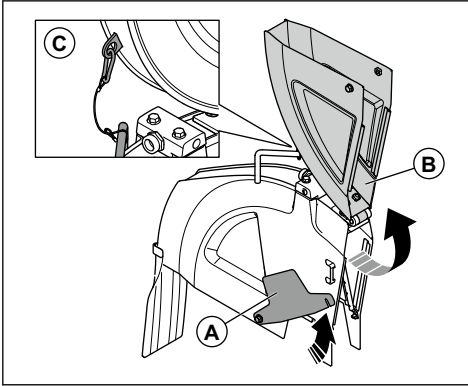

2. Lift the blade guard front (B) and lock the blade guard in upright position with a wire and carabiner (C).
3. Open the water valve.

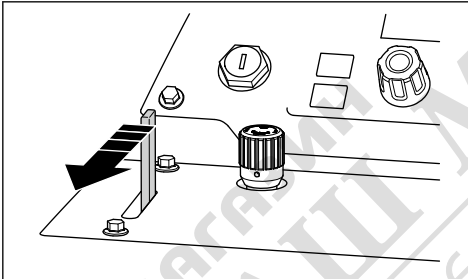

4. Make sure that the jets of water go straight out from the holes and onto each side of the cutting blade.

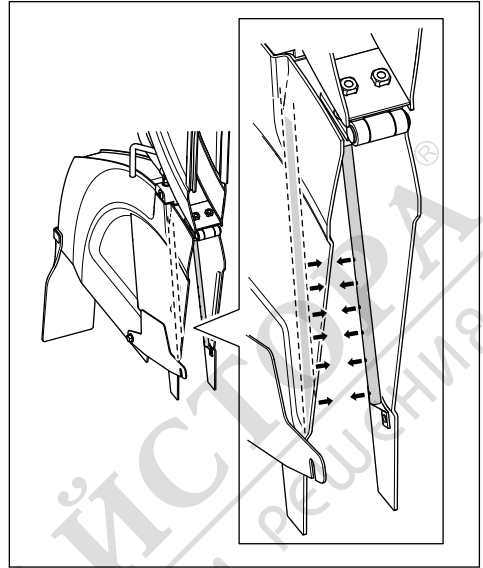

5. Make sure that there are no leakages in the water pipes.
6. Replace the water pipes if they are damaged.

To drain the water separator for the fuel filter

1. Put a container below the hose at the bottom of the water separator for the fuel filter.

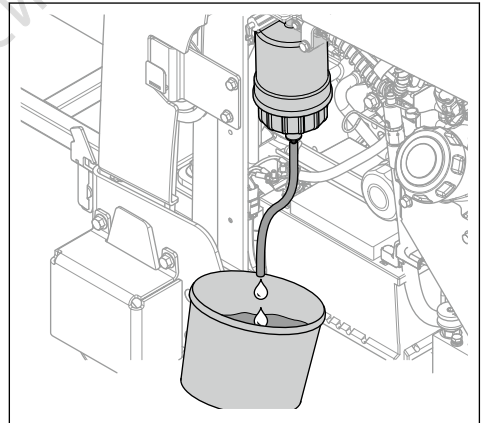

- Turn the engine start switch to ignition on position (A). Do not start the engine.

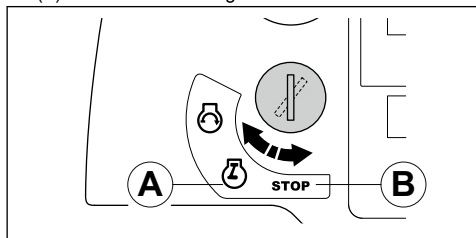

- Let the fuel pump operate for approximately 15 seconds to increase the pressure in the fuel system.
- Turn the engine start switch to the stop position (B).
- Loosen the tap and drain the water from the water separator into the container.
- Tighten the tap.
- Discard the water as chemical waste. Refer to *Disposal on page 40*.

To replace the engine oil and engine oil filter

- Put a cover on the battery to prevent oil spill on the battery.
- Remove the cap (A) from the oil drain hose for engine oil.

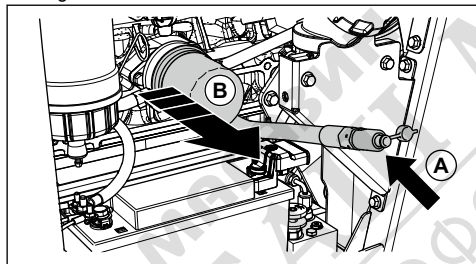

- Open the valve and bend the hose down to drain the engine oil.
- Remove the engine oil filter (B) and discard it.
- Close the valve.
- Fill a new engine oil filter with oil and install the engine oil filter on the product.

- Open an oil tank cap and fill the system with engine oil. Refer to *Technical data on page 41*.

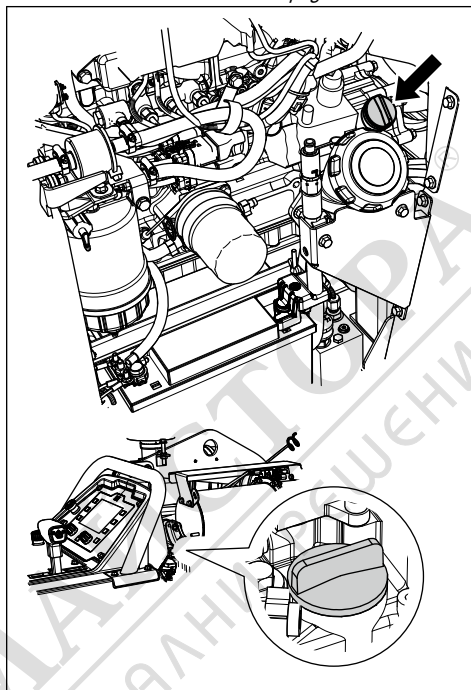

Note: There are 2 oil tank caps for engine oil.

To clean the radiator air filter



CAUTION: Do not operate the product without the radiator air filter installed.

- Clean the radiator air filter with soap and water.

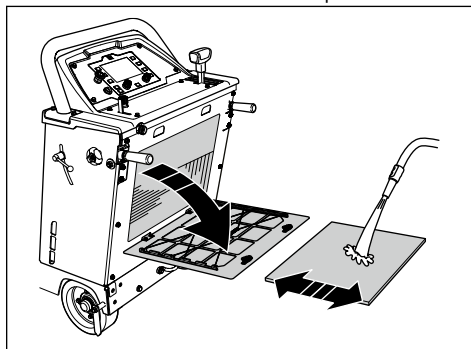

- Always replace a damaged radiator air filter.

To replace the hydraulic system filter

1. Remove the hydraulic system filter and discard it.

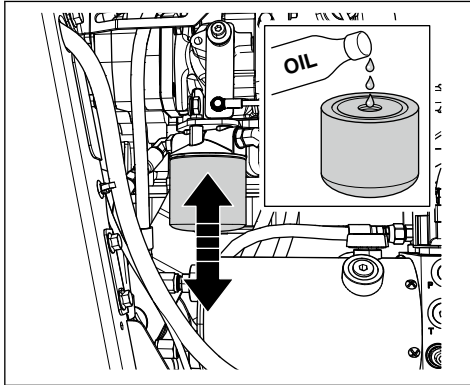

2. Fill a new hydraulic system filter with oil. Refer to *Technical data on page 41* for the correct type of oil.
3. Lubricate the seal with some drops of oil.
4. Install the hydraulic system filter.
5. Make sure that the product is level.
6. Remove the plug from the inspection opening on the hydraulic reservoir.

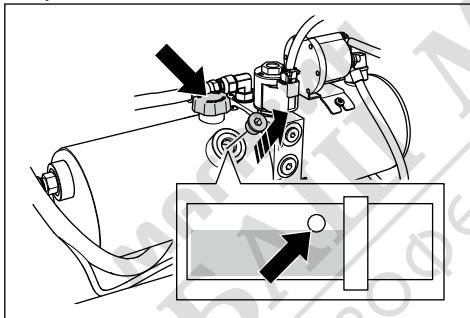

7. Remove the hydraulic reservoir cap and fill with new oil to the correct oil level. Refer to *To do a check of the hydraulic oil level on page 32*.
8. Install the hydraulic reservoir cap.
9. Install the plug in the inspection opening on the hydraulic reservoir.

To do a check of the V-belts

- Pull and release the V-belts, 1 at a time. The belts must give a long sound, not a short sound.

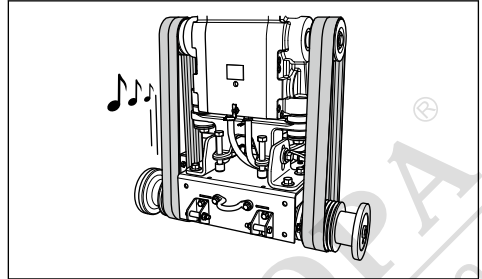

- a) If you hear a long, clear sound from the V-belts, the tension is correct.
 - b) If you hear only a short sound from the V-belts, the tension is too low. Refer to *To increase the tension of the V-belts on page 31*.
- Examine the V-belts for wear and damages. Replace damaged V-belts.



CAUTION: Do not replace only 1 of the V-belts. Always replace all 4 V-belts at the same time.

To increase the tension of the V-belts



CAUTION: The tension of new V-belts must be increased after the first 2-4 hours of operation.

1. Loosen the 2 bolts (A) with the blade shaft wrench.

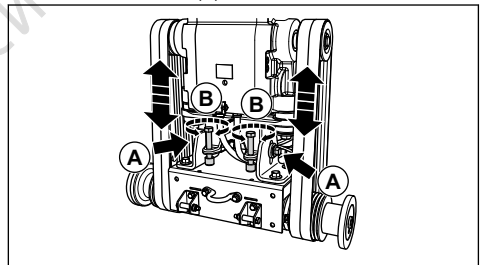

2. Turn the bolts for the belt tension (B) clockwise until the V-belts are tight.



CAUTION: Turn the 2 bolts for the belt tension equally. The tension must be the same in the 2 V-belts.

3. Do a check of the V-belts. Refer to *To do a check of the V-belts on page 31*.
 - a) If the tension of the V-belts is too low, turn the bolts for the belt tension some more.
 - b) Do this procedure again until the V-belt tension is correct.

4. Tighten the 2 bolts (A).
5. Loosen the bolts for the belt tension counterclockwise approximately 1/16 of a turn.

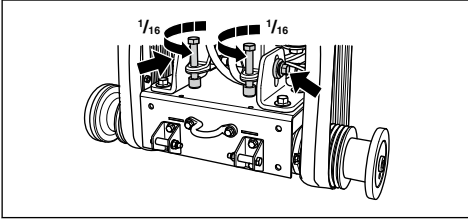

CAUTION: Make sure that the 4 V-belts have the same tension. Do not adjust the tension of the V-belts too much.

To examine the wheels

- Examine the wheels for wear or damage. Replace wheels and hubs if they are damaged or worn out.

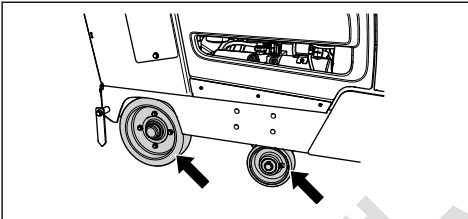

- Examine if the rear wheel hubs and wheels are loose. Tighten loose screws and nuts.

To do a check of the hydraulic oil level

1. Remove the plug in the inspection opening on the hydraulic reservoir. Refer to *Product overview, right side on page 3* for the hydraulic reservoir position.

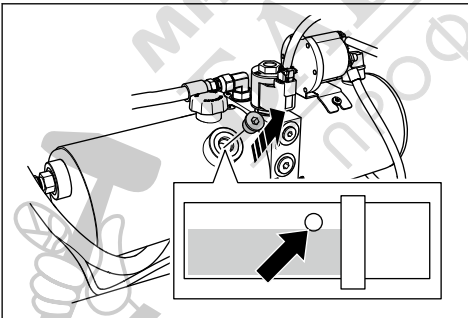

2. Make sure that the oil level is at the bottom edge of the opening on the hydraulic reservoir.

3. If it is necessary, remove the hydraulic reservoir cap and fill the hydraulic reservoir until the oil level is correct. Refer to *Product overview, right side on page 3* for the correct type of oil.

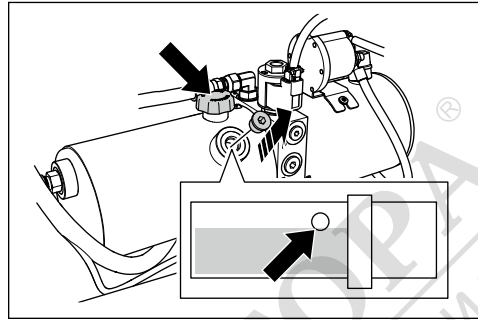

CAUTION: Do not fill too much. Oil can come out of the inspection opening.

4. Install the hydraulic reservoir cap.
5. Install the plug in the inspection opening on the hydraulic reservoir.

To replace the hydraulic oil

1. Remove the plug from the inspection opening on the hydraulic reservoir.

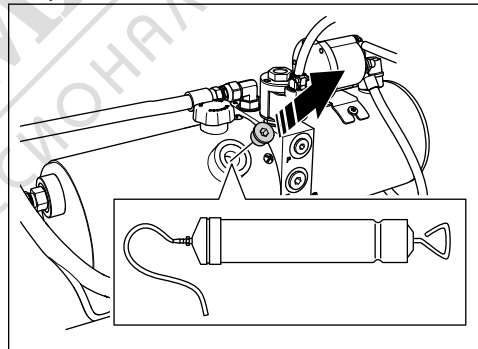

2. Use a manual oil pump to drain the oil through the inspection opening on the hydraulic reservoir.
3. Replace the hydraulic system filter. Refer to *To replace the hydraulic system filter on page 31*.

To lubricate the product

1. Clean the 8 grease nipples.

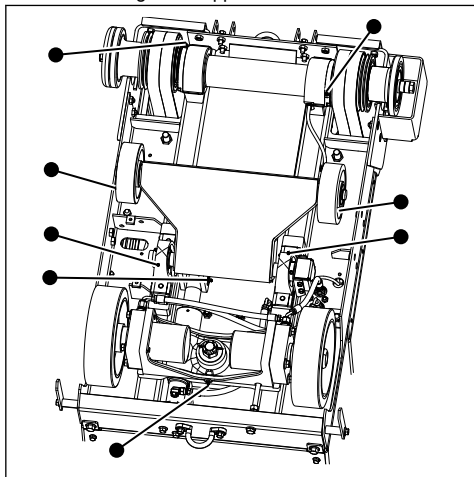

2. Replace broken or blocked grease nipples.
3. Lubricate the front wheels.
4. Lubricate the pivot bearings of the front axle.
5. Lubricate the blade shaft. Push the grease pump 2 times at each end of the blade shaft.
6. Lubricate the pivot pin on the hydraulic cylinder.
7. Lubricate the rear axle bearing.

For more information about lubrication, refer to *Technical data on page 41*.

To replace the oil in the gearbox

There are 2 alternatives for how to drain the oil from the gearbox.

1. To drain the oil with a manual oil pump, do this procedure:

- a) Remove the plug in the inspection window at the front of the product.

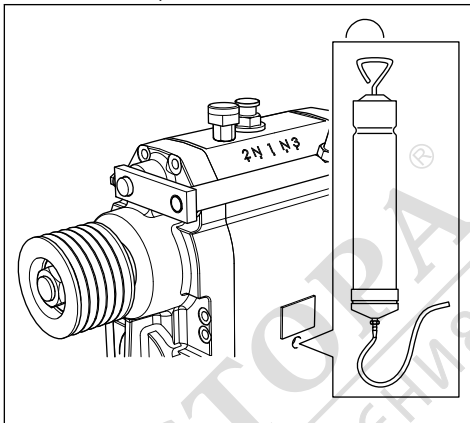

- b) Use an oil pump to drain the oil through the inspection window.

2. Remove the left screw.

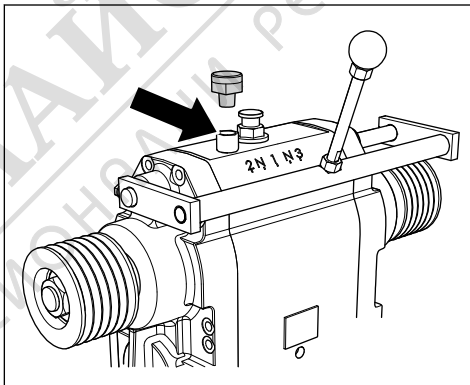

3. To drain the oil through the hole below the engine, do this procedure:



- a) Put a container below the engine.

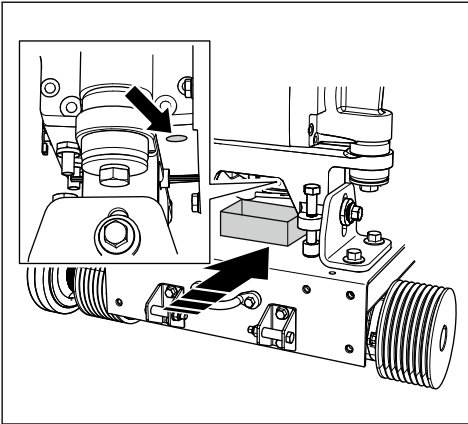

- b) Loosen the screw and let the oil run out into the container.
 c) Tighten the screw.
4. Fill oil into the tube while you look through the inspection window.

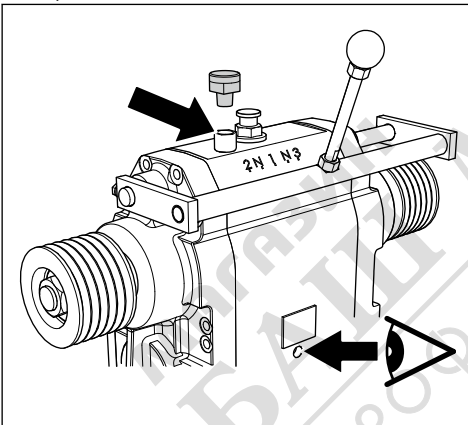

5. Fill until you see that the oil level is correct.
 6. Tighten the left screw.

To replace the fuel filter



WARNING: Use protective gloves to prevent skin irritation. Fuel can come from the fuel filter and onto your skin.

1. Close the valve of the prefilter. For more information, refer to the engine manual.
2. Turn the fuel filter counterclockwise to remove it.
3. Replace the fuel filter.
4. Fill the new fuel filter with diesel fuel.

5. Lubricate the seal with some drops of diesel fuel.

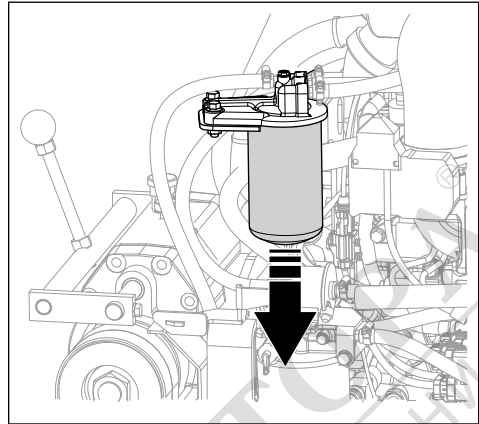

6. Install the fuel filter.
7. Open the valve of the prefilter before you start the engine.

To replace the radiator coolant



WARNING: Risk of burn injuries. Let the engine become cool before you open the radiator coolant lid.

1. Remove the rear cover.

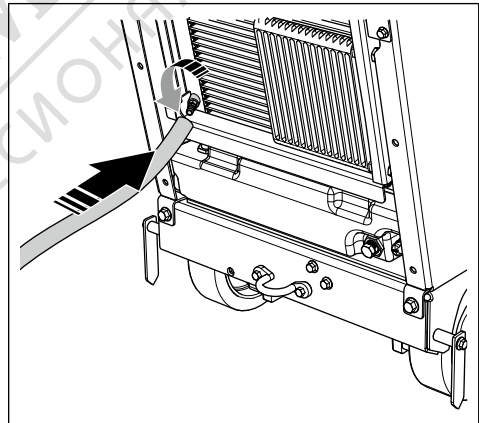

2. Put an extension on the valve.
3. Open the valve.
4. Remove the radiator coolant lid. The radiator coolant drains from the system.
5. Close the valve.
6. Fill with radiator coolant until the level is between the 2 marks on the radiator coolant bottle. Refer to *Technical data on page 41* for correct radiator coolant type and mixture.

To replace the air filters

1. Open the 3 clamps of the air filter housing and remove the air filter housing.

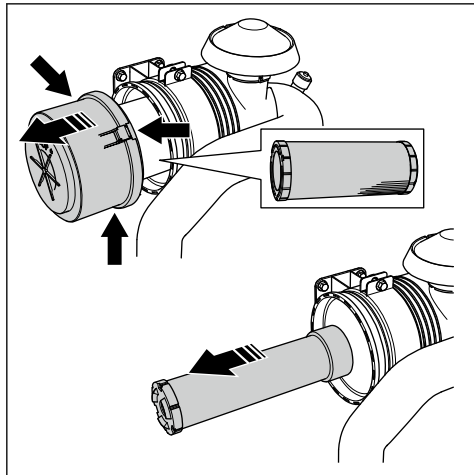

2. Replace the outer air filter and the inner air filter.
3. Install the air filters in opposite sequence.

Note: If the 3 clamps of the air filter housing cannot be closed, the outer air filter is not correctly installed.

Battery maintenance

Note: The battery on your product is maintenance free. Do not open or remove the caps or the covers.

To connect and disconnect the battery

1. Connect the red battery cable (A) to the POSITIVE (+) battery terminal on the battery.

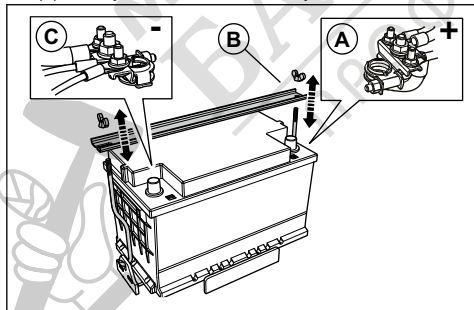

2. Install the battery holder (B).
3. Connect the black battery cable (C) to the NEGATIVE (-) battery terminal on the battery.
4. Disconnect the battery cables in the opposite sequence of how they were connected.



WARNING: Always disconnect the NEGATIVE (-) battery terminal first.

To do a check of the battery

- Do a check of the battery daily.
 - a) Set the engine start switch to the ignition on position.
 - b) Examine the battery gauge in the display. It must not be below 12V.

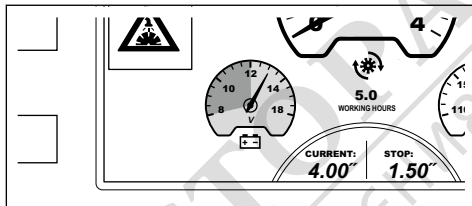

- If the battery gauge is below 12V, charge or replace the battery.
- Replace the battery if it cannot keep the voltage. This can occur if the product is not operated for a long time. For information about recommended batteries, refer to *Technical data on page 41*.
- Charge the battery regularly.
- Keep the battery terminals and the battery cables clean.

To do an emergency start of the engine

If the battery is too weak to start the engine, you can use jumper cables to do an emergency start. This product has a 12 V system with negative ground. The product that is used for the emergency start must also have a 12 V system with negative ground and minimum 700 CCA.

To connect the jumper cables



WARNING: Risk of explosion because of explosive gas that comes from the battery. Do not connect the negative terminal of the charged battery to or near the negative terminal of the weak battery.



CAUTION: Do not use the battery of your product to start other vehicles.

1. Connect one end of the red battery cable to the POSITIVE (+) battery terminal (A) on the weak battery.

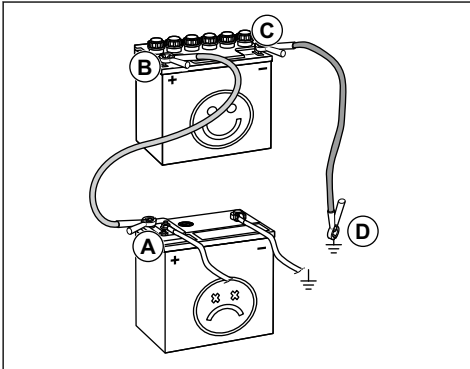

2. Connect the other end of the red battery cable to the POSITIVE (+) battery terminal (B) on the charged battery.



WARNING: Do not let the ends of the red battery cable touch the chassis. This will cause a short circuit.

3. Connect one end of the black battery cable to the NEGATIVE (-) battery terminal (C) on the charged battery.
4. Connect the other end of the black battery cable to a CHASSIS GROUND (D), away from the fuel tank and the battery.

To remove the jumper cables

Note: Remove the jumper cables in the opposite sequence to how you connect them.

1. Remove the BLACK cable from the chassis.
2. Remove the BLACK cable from the fully charged battery.
3. Remove the RED cable from the 2 batteries.

Regeneration

To decrease the exhaust emissions, the diesel engine has a diesel particulate filter (DPF) that collects unwanted material from the exhaust. The concentration of unwanted material in the diesel particulate filter increases during operation and it is necessary to clean the diesel particulate filter regularly. The procedure to clean the diesel particulate filter, a DPF regeneration, is a fully automatic procedure that is started by the operator and controlled by the engine control unit. There are different modes of regeneration:

- Stationary regeneration standby

- Stationary regeneration
- Regeneration back up mode
- Recovery regeneration

Stationary regeneration standby

When these warning symbols show on the display, the engine is in regeneration standby.



The power output of the engine is decreased. During the first 2 hours, the power output is decreased to 85% and then to 50%. After 8 hours, or when the soot load increases to more than 11.5 g/l, the maximum engine speed is decreased to 1500 rpm.

It is necessary to do a stationary regeneration in the shortest time possible after the warning symbols show.

Stationary regeneration

Approximately 30 minutes are necessary to do a stationary regeneration. Refer to the operator's manual for the control panel for information on how to do the stationary regeneration.

Regeneration backup mode

When these warning symbols show on the display, the engine is in regeneration backup mode.



The power output of the engine is decreased to 50%. The maximum engine speed is decreased to low idle speed. It is necessary to do a recovery regeneration for the engine to operate correctly again.

Recovery regeneration

Approximately 3 hours are necessary to do a recovery regeneration. Refer to the operator's manual for the control panel for information on how to do the recovery regeneration.

Note: The operator can do a recovery regeneration from the control panel on all products with a production date from January 1 2019. For engines with a production date before January 1 2019, an ECU software update is necessary before the operator can do a recovery regeneration from the control panel. If the update of the ECU software is not done, the Yanmar servicing tool SmartAssist must be used to do a recovery regeneration. Speak to your Husqvarna service center for more information.

Troubleshooting

Troubleshooting

on the control panel. Examine the product fully before you start the product again.



WARNING: If the engine or cutting blade stops, lift the cutting blade fully from the cut. Set the engine start switch to the stop position and push the machine stop button

For more information about warning symbols, refer to the operator's manual for the control panel.

Problem	Cause	Solution
The engine stops during operation.	The fuel tank is empty. The related warning symbol shows on the display.	Fill the fuel tank with correct fuel type.
	The water safety switch stops the engine because there is no water pressure. The related warning symbol shows on the display together with a warning message.	Disengage the water safety switch. Do a check of the water supply.
	The machine stop button is pushed down. The related warning symbol shows on the display together with a warning message.	Pull the machine stop button up to reset the machine stop.
	Too high load on the cutting blade.	Listen to the sound of the engine. If the engine speed decreases, pull the lever for speed control rearward.
	A fuse is broken.	Replace broken fuses.
The cutting blade stops during operation.	The drive belt tension is not sufficient.	Examine the tension of the drive belt.
	The blade clutch is disengaged.	Engage the blade clutch to engage the blade drive. Make sure that the engine speed is 1200 rpm or less when you engage the blade clutch.
	The blade clutch has an electrical failure or broken fuse.	Examine the fuses. Replace broken fuses.
The cutting blade lowers too quickly.	The valve that controls the speed for the cutting blade position is open too much.	Turn the knob for adjustment of the blade lowering speed clockwise until an applicable speed is set.
The cutting blade cuts too slowly.	The cutting blade is blunt or the feeding pressure is too high.	Decrease the cutting depth and engine speed for a short time.
The control unit restarts when you try to start the engine.	The battery voltage is too low.	Charge the battery, replace the battery or use jumper cables.

Transportation, storage and disposal

Transportation



WARNING: Be careful during transportation. The product is heavy and can cause injury or damage if it falls or moves during transportation.

The wheels let you move the product manually for shorter distances. For longer distances, lift the product to move it or put the product on a vehicle.



CAUTION: Do not tow the product behind a vehicle.

- Safety the product during transportation. Make sure that it cannot move.
- Remove the cutting blade before transportation of the product.
- Remove all tools and wrenches.
- For transportation of the product and fuel, make sure that there are no leaks or fumes. Sparks or open flames, for example from electrical devices or boilers, can start a fire.
- Always use approved containers for transportation of fuel.
- Examine new cutting blades for transport damage.

To move the product with the engine on

1. Turn the engine start switch to ignition on position (A).

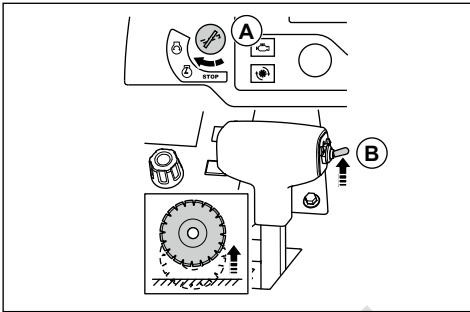

2. Push the switch for cutting depth adjustment (B) up until the cutting blade does not touch the ground.
3. Put the lever for speed control into the stop position.

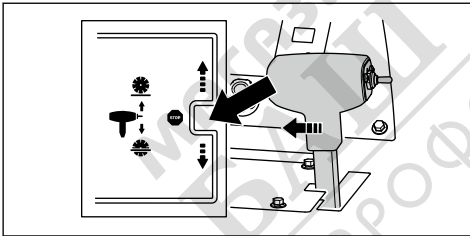

4. If the product has a blade clutch, make sure that the blade clutch is disengaged. The blade clutch is disengaged when the symbol on the display is not in a different color.

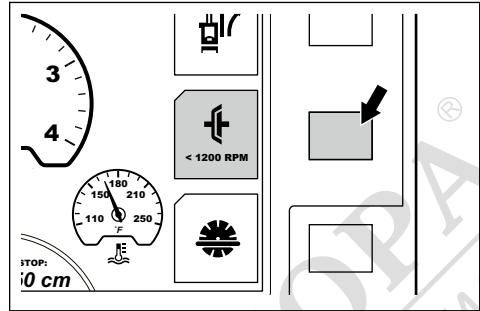

5. If the product does not have a blade clutch, remove the blade or move the gearbox lever to neutral position. Refer to *To remove the cutting blade on page 16* and *To change gears on a 3-speed gearbox model on page 18*.



WARNING: For products that do not have a blade clutch, the cutting blade starts to rotate when the engine starts. Do not move the product to the side or out of the work area if the cutting blade rotates.

6. Start the product. Refer to *To start the product on page 21*.
7. Push the lever for speed control forward for forward saw movement, or rearward for reverse movement. The more you push the lever for speed control, the more the speed increases. Refer to *Technical data on page 41*.

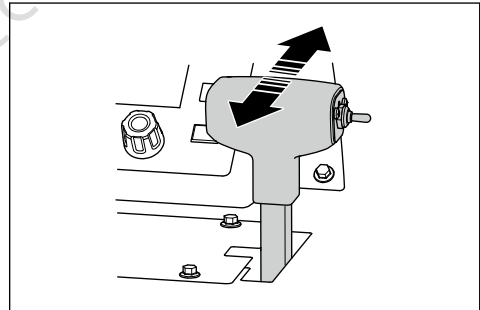

WARNING: Do not open the transmission bypass valve to neutral position while the product is parked on a slope. The product can move away from you and cause injury to bystanders.

- Adjust the resistance on the lever for speed control with the nut on the side of the lever for speed control.

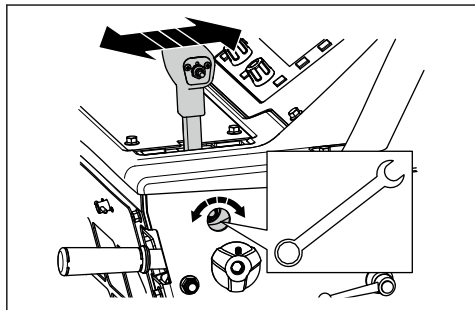

To move the product up and down a ramp



WARNING: Be very careful when you move the product up and down ramps with the engine on. The product is heavy and there is a risk of injury if the product falls or moves too quickly.



WARNING: For ramps with a large angle, always use a winch. Do not walk or stay below the product.

- To move the product down a ramp, operate the product rearward slowly.
- To move the product up a ramp, operate the product forward slowly.

To move the product with the engine off

- Turn the engine start switch to ignition on position (A).

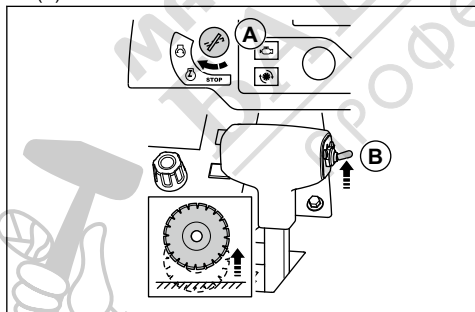

- Push the switch for cutting depth adjustment (B) up until the cutting blade does not touch the ground.

- Put the lever for speed control into the stop position.

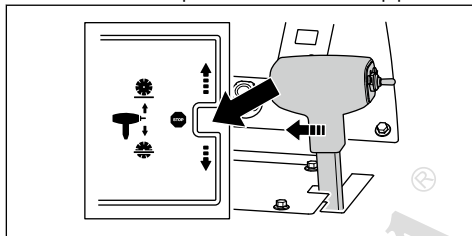

- Turn the transmission bypass valve counterclockwise to the end position to disengage the transmission.

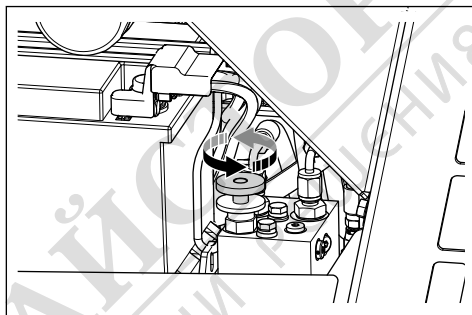

- Hold the operation handles and push the product to move it.



WARNING: Do not push the product on a slope while the transmission bypass valve is in neutral position. The product can move away from you and cause injury to bystanders.

To lift the product



WARNING: Make sure that the lifting equipment has the correct dimension. The type plate on the product shows the product weight.



WARNING: Do not lift a damaged product. Make sure that the lifting eye is correctly installed and not damaged.



WARNING: Do not walk or stay below or near a lifted product.



CAUTION: Do not use the operation handles to lift the product.

- Attach the lifting equipment through the lifting eye.

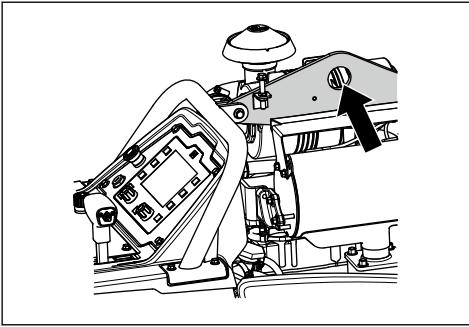

- Keep the battery in a cool and dry area.

For long-term storage, also do these steps:

- Clean the product and do a complete servicing.
- Lubricate all lubrication points.
- Disconnect the battery cable from the negative battery terminal and put the battery cable at a safe distance away from the battery.
- Do a trickle charging of the battery during long-term storage.
- Fill the fuel tank to prevent water in the fuel system.
- Keep the product in a dry and frost-free area.
- Drain the water separator for the fuel filter.
- Do a check that the freezing point of the engine coolant is sufficient for the temperatures in the storage location.
- Put a protective cover on the product. This is especially important for storage outdoors.
- Replace the engine oil after a long-term storage.

To safely the product to a transportation vehicle

1. Put 1 strap through the tie-down bracket at the front of the product and attach the strap to the vehicle.

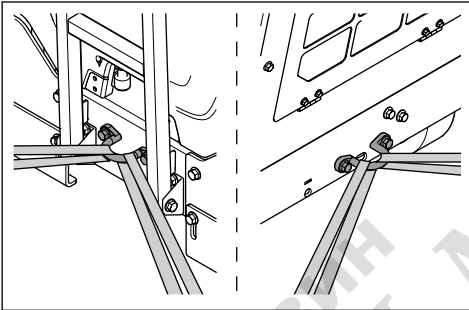

2. Put 1 strap through the tie-down bracket at the rear of the product and attach the strap to the vehicle.

Disposal

- Chemicals can be dangerous and must not be discarded on the ground. Always discard used chemicals at a service center or an applicable disposal location.
- When the product is worn out, send it to the dealer or to an applicable recycling location.
- Oil, oil filters, fuel and the battery can have negative effects on the environment. Obey the local recycling requirements and applicable regulations.
- Do not discard the battery as domestic waste.
- Send the battery to a Husqvarna service agent or discard it at a disposal location for used batteries.

Storage

- The product does not have a parking brake. Do not go away from the product if it is on a slope. If it is necessary to park the product on a slope, make sure that the product is sufficiently attached and cannot move.
- Keep the product in a locked area to prevent access for children or persons that are not approved.
- Drain water from the gearbox.
- Set the engine start switch to the stop position.
- Set the lever for speed control to the stop position.
- Remove the cutting blade from the product.
- Keep the cutting blades in a safe area to prevent damage.
- Keep the cutting blades in a dry and frost-free area.
- Examine new cutting blades for storage damage.
- For storage of the product and fuel, make sure that there are no leaks or fumes. Sparks or open flames, for example from electrical devices or boilers, can start a fire.
- Always use approved containers for storage of fuel.

Technical data

Technical data

Engine *	
Engine brand, type	Yanmar, 4TNV88C-DHQ
Engine power, kW/hp@rpm ¹	35.5/47.6@3000
Displacement, dm ³ /cu.in.	2.2/134
Cylinders	4
Air filter	Radial seal with pre-cleaner and restriction indicator
Starter	Electric
Fuel	Ultra-low-sulfur diesel fuel only

* = For further information and questions about this specific engine, refer to the engine manual or the web site of the engine manufacturer.

Fuel and lubrication system	
Fuel tank capacity, l/gal	24.5/6.5
Oil tank capacity, l/qts	7.1/7.5
Engine oil	SAE 15W40 or SAE 10W30, API Class CJ-4, ACEA E6-08, ACEA E9-08
Gearbox oil	SAE 75W90
Gearbox oil tank capacity, l/qts	1-Speed gearbox model: 0.95/1 3-Speed gearbox model: 1.77/1.87
Grease	Quality: NLGI 2. Standard: SAE J310
Hydraulic oil	SAE 15W40, API Class SE, API Class CC, API Class CD
Coolant fluid	Ethylene glycol and water, 50/50 mixture. Supplied in the product at purchase. Propylene glycol and water, 50/50 mixture
	 CAUTION: Do not make the mixture directly in the tank. It is easier to get the correct 50/50 mixture if you make the mixture in a container.

¹ As specified by engine manufacturer. The power rating of the engines indicated is the average gross power output (at specified r.p.m.) of a typical production engine for the engine model measured to SAE J1995. Mass production engines may differ from this value. Actual power output for the engine installed in the final machine will depend on the operating speed, environmental conditions and other variables.

Battery	
Terminal type	T6
BCI	91
Voltage, V	12
Capacity, Ah	60–100
CCA, A	660–760
Max. size L×W×H, mm/in.	280×175×175/11×6.9×6.9

Saw setup	350/14	500/20	650/26	750/30	900/36
Blade guard capacity, mm/in.	350/14	500/20	650/26	750/30	900/36
Max. cutting depth, mm/in.	118/4.75	193/7.75	262/10.5	312/12.5	374/15
Blade shaft, rpm	3197	2400	1866	1628	1355
Approximate blade shaft output, kW/hp	31/42				
Arbor size, mm/in.	25.4/1 with single drive pin				
Quick disconnect blade flange diameter, mm/in.	114.5/4.5	114.5/4.5	127/5	127/5	152.5/6
Blade shaft drive	3 VX V-belts per side				
Blade coolant	Water				
Blade guard attachment	Slip-on, auto-latch				
Propulsion	Hydraulic				
Max. ground speed	Infinitely variable: 0-37 m/min / 0-122 fpm forward and reverse. 25 m/min maximum reverse speed on CE models.				
Chassis	Heavy duty, rigid, box and channel section construction				
Nominal weight (uncrated), kg/lb	751/1656	756/1667	761/1678	765/1687	771/1700
Max. operating weight incl. optional accessories, kg/lb	791/1744	799/1761	808/1781	817/1801	829/1828

Noise and vibration emissions	
Sound power level, measured dB (A)	113
Sound power level, guaranteed L _{WA} dB (A) ²	119

² Noise emissions in the environment measured as sound power (L_{WA}) in conformity with EC directive 2000/14/EC. The difference between guaranteed and measured sound power is that the guaranteed sound power also includes dispersion in the measurement result and the variations between different machines of the same model according to Directive 2000/14/EC.

Noise and vibration emissions	
Sound pressure level at the operator's ear, dB (A) ³	102
Vibration level, a_{hv} , m/s^2 , right handle/left handle ⁴	<2.5/<2.5

Noise and vibration declaration statement

These declared values were obtained by laboratory type testing in accordance with the stated directive or standards and are suitable for comparison with the declared values of other products tested in accordance with the same directive or standards. These declared values are not suitable for use in risk assessments and values measured in individual work places may be higher. The actual exposure values and risk of harm experienced by an individual user are unique and depend upon the way the user works, in what material the product is used, as well as upon the exposure time and the physical condition of the user, and the condition of the product.



МАГАЗИН
БАШ МАЙСТОРА®
ПРОФЕСИОНАЛНИ РЕШЕНИЯ

- ³ Noise pressure level according to ISO EN 13862. Reported data for noise pressure level has a typical statistical dispersion (standard deviation) of 2.5 dB(A).
- ⁴ Vibration level according to EN 13862. Reported data for vibration level has a typical statistical dispersion (standard deviation) of 1 m/s^2 .

Product dimensions

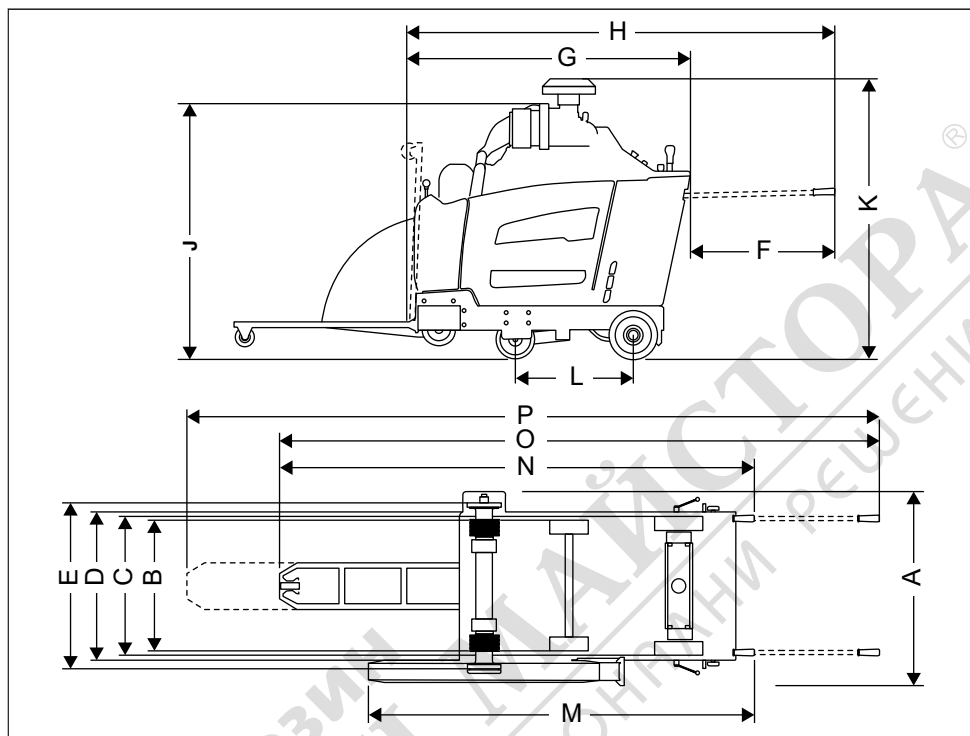

A	Width, mm/in.	844/33 ¼	J	Min. total height (no exhaust pipe, no precleaner cap), mm/in.	1289/50 ¾
B	Center to center wheel width, mm/in.	Front: 518/20 ¾, rear: 533/21	K	Max. total height (top of precleaner), mm/in.	1332/52 ½
C	Outside to outside wheel width, mm/in.	Front: 569/22 ¾, rear: 609/24	L	Wheel base length, mm/in.	427/16 ¾
D	Frame width, mm/in.	635/25	M	Length, guard to handle (handles in), mm/in.	1753/69
E	Inner flange to inner flange width, mm/in.	726,5/28 ¾	N	Max. total length (handles in), mm/in.	2273/89 ½
F	Handle extension, mm/in.	809/31 ¾	O	Max. total length (handles out, pointer down), mm/in.	2964/116 ¾
G	Min. saw length (pointer and guard up, no handles), mm/in.	1485/58 ½	P	Max. total length (handles out, pointer extended), mm/in.	3444/135 ½
H	Saw length (pointer up, handles out), mm/in.	2191/86 ¼			

Relays and fuses

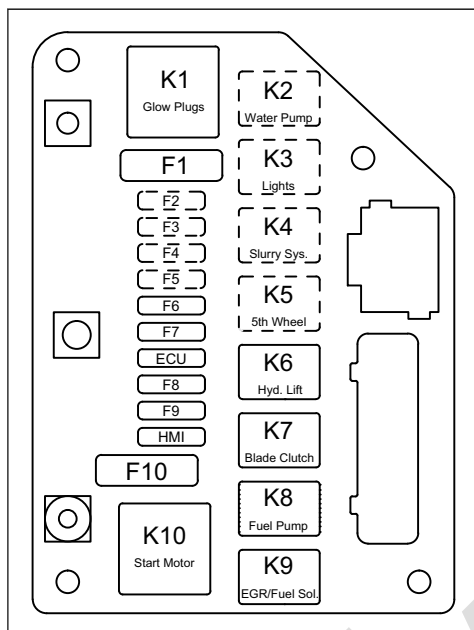

Function	Designation	Relay (A)	Designation	Fuse (A)
Glow plugs	K1	70	F1	60
Water pump (optional)	K2	25	F2	25
Lights (optional)	K3	25	F3	25
Slurry system (optional)	K4	25	F4	25
5th wheel (optional)	K5	25	F5	25
Hydraulic lift pump	K6	25	F6	25
Blade clutch	K7	25	F7	15
Fuel pump	K8	25	F8	20
EGR/Fuel Sol.	K9	25	F9	20
Start motor	K10	70	F10	60
ECU	n/a	n/a	ECU	25
HMI	n/a	n/a	HMI	25

Approved Husqvarna accessories

- Rear weight kit, 2 bars.
- Dual light kit.
- Water pump kit.
- 5th wheel kit.



МАГАЗИН
БАШ МАЙСТОРА®
ПРОФЕСИОНАЛНИ РЕШЕНИЯ

EC Declaration of Conformity

EC Declaration of Conformity

We, **Husqvarna AB**, SE-561 82 Huskvarna, Sweden, tel: +46-36-146500, declare on our sole responsibility that the product:

Description	Floor cutting-off machine
Brand	Husqvarna
Type/Model	FS5000 D
Identification	Serial numbers dating from 2019 and onwards

complies fully with the following EU directives and regulations:

Directive/Regulation	Description
2006/42/EC	"relating to machinery"
2000/14/EC	"relating to outdoor noise"

and that the following harmonized standards and/or technical specifications are applied;

EN ISO 12100:2010

EN 13862/A1:2009

For information relating to noise emissions, refer to the chapter *Technical data on page 41*.

2019-05-24



Edvard Gulis
R&D Director, Concrete Sawing & Drilling
Husqvarna AB, Construction Division
Responsible for technical documentation