

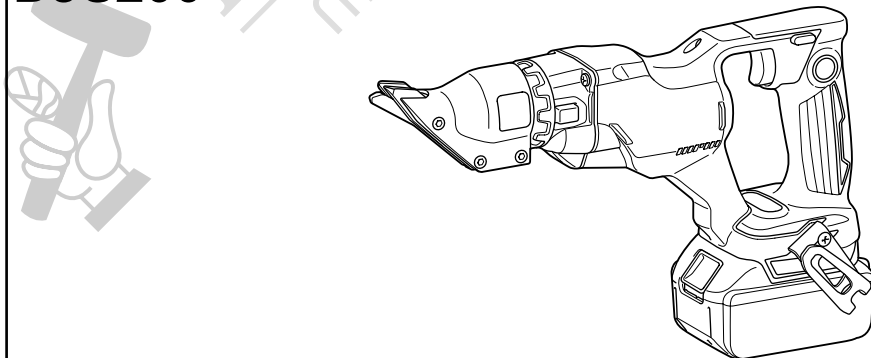

EN	Cordless Metal Shear	INSTRUCTION MANUAL	4
FR	Cisaille sans Fil	MANUEL D'INSTRUCTIONS	9
DE	Akku-Blechscherer	BETRIEBSANLEITUNG	15
IT	Cesoie per metallo a batteria	ISTRUZIONI PER L'USO	21
NL	Accuplaatschaar	GEBRUIKSAANWIJZING	27
ES	Cizalla Inalámbrica para Metal	MANUAL DE INSTRUCCIONES	33
PT	Tesoura Faca a Bateria	MANUAL DE INSTRUÇÕES	39
DA	Akku metalpladesaks	BRUGSANVISNING	44
EL	Φορητό κοπτικό μετάλλων	ΕΓΧΕΙΡΙΔΙΟ ΟΔΗΓΙΩΝ	49
TR	Akülü Sac Kesme Makinesi	KULLANMA KILAVUZU	55

DJS200



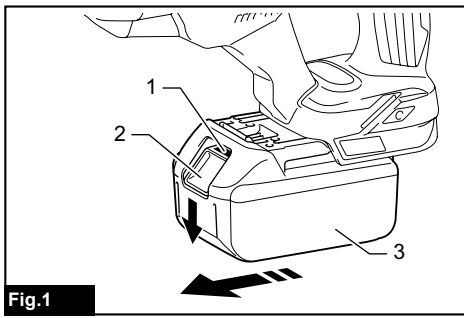

Fig.1

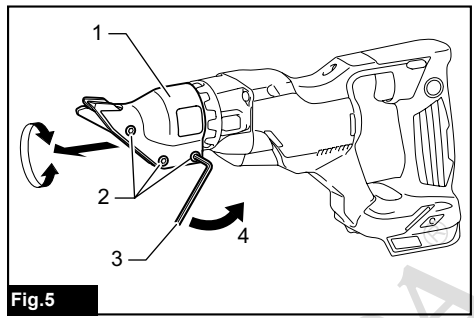

Fig.5

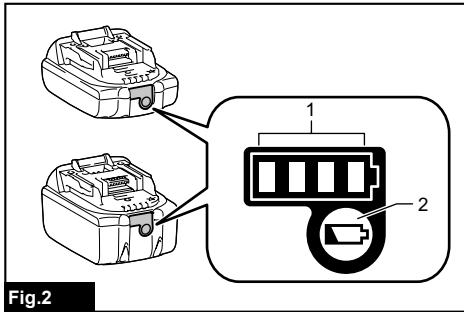

Fig.2

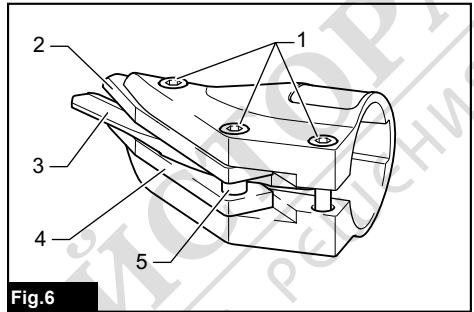

Fig.6

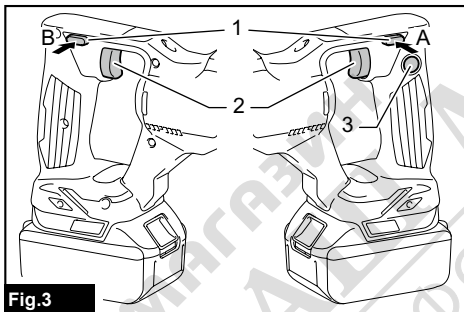

Fig.3

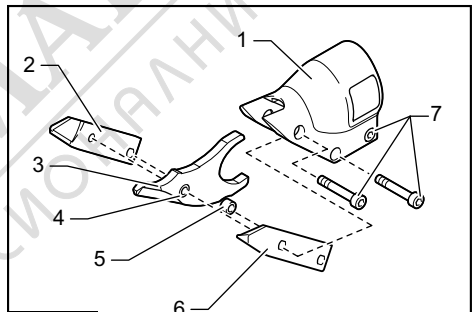

Fig.7

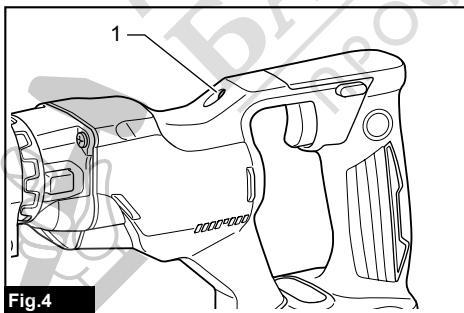

Fig.4

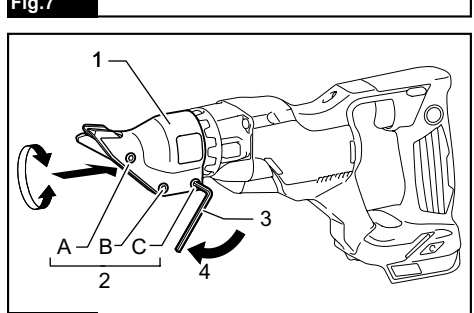

Fig.8

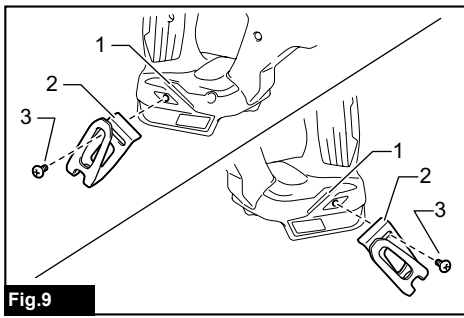

Fig.9

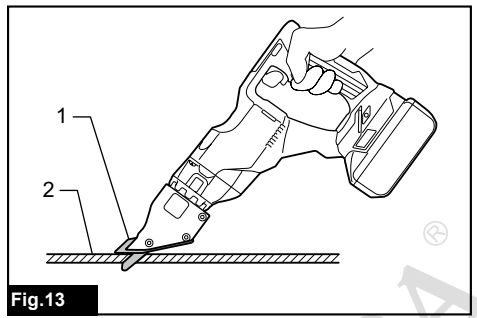

Fig.13

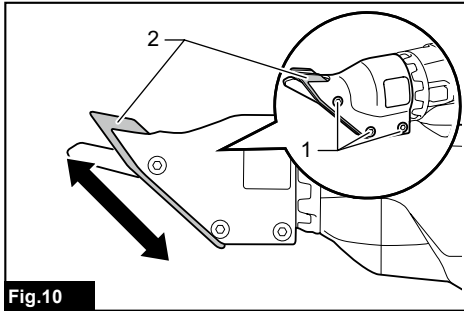

Fig.10

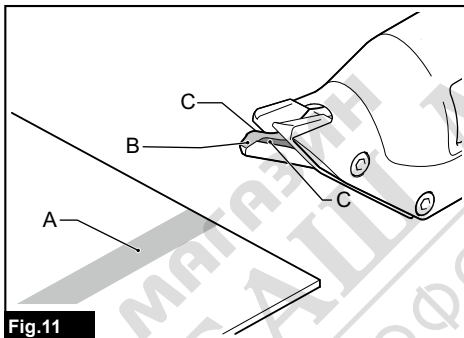

Fig.11

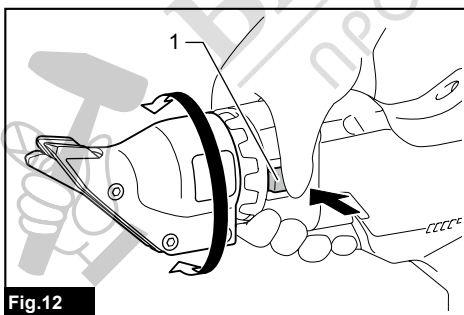

Fig.12

SPECIFICATIONS

Model:		DJS200
Max. cutting capacities *	Steel up to 400 N/mm ²	2.0 mm (14 ga)
	Stainless Steel up to 600 N/mm ²	1.6 mm (16 ga)
Strokes per minute		0 - 3,000 min ⁻¹
Overall length		345 mm
Rated voltage		D.C. 18 V
Net weight		2.2 - 2.5 kg

- Due to our continuing program of research and development, the specifications herein are subject to change without notice.
- Specifications and battery cartridge may differ from country to country.
- The weight may differ depending on the attachment(s), including the battery cartridge. The lightest and heaviest combinations, according to EPTA-Procedure 01/2014, are shown in the table.
- * The Max. cutting capacities mentioned above are rough guide. Some material may not be cut.

Applicable battery cartridge and charger

Battery cartridge	BL1815N / BL1820B / BL1830B / BL1840B / BL1850B / BL1860B
Charger	DC18RC / DC18RD / DC18RE / DC18SD / DC18SE / DC18SF / DC18SH

- Some of the battery cartridges and chargers listed above may not be available depending on your region of residence.

⚠WARNING: Only use the battery cartridges and chargers listed above. Use of any other battery cartridges and chargers may cause injury and/or fire.

Intended use

The tool is intended for cutting sheet steel and stainless sheet steel.

Noise

The typical A-weighted noise level determined according to EN62841-2-8:

Sound pressure level (L_{pA}) : 75 dB(A)

Uncertainty (K) : 3 dB(A)

The noise level under working may exceed 80 dB (A).

NOTE: The declared noise emission value(s) has been measured in accordance with a standard test method and may be used for comparing one tool with another.

NOTE: The declared noise emission value(s) may also be used in a preliminary assessment of exposure.

⚠WARNING: Wear ear protection.

⚠WARNING: The noise emission during actual use of the power tool can differ from the declared value(s) depending on the ways in which the tool is used especially what kind of workpiece is processed.

⚠WARNING: Be sure to identify safety measures to protect the operator that are based on an estimation of exposure in the actual conditions of use (taking account of all parts of the operating cycle such as the times when the tool is switched off and when it is running idle in addition to the trigger time).

Vibration

The vibration total value (tri-axial vector sum) determined according to EN62841-2-8:

Work mode: cutting sheet metal

Vibration emission ($a_{h,D}$) : 6.5 m/s²

Uncertainty (K) : 1.5 m/s²

NOTE: The declared vibration total value(s) has been measured in accordance with a standard test method and may be used for comparing one tool with another.

NOTE: The declared vibration total value(s) may also be used in a preliminary assessment of exposure.

⚠️WARNING: The vibration emission during actual use of the power tool can differ from the declared value(s) depending on the ways in which the tool is used especially what kind of workpiece is processed.

⚠️WARNING: Be sure to identify safety measures to protect the operator that are based on an estimation of exposure in the actual conditions of use (taking account of all parts of the operating cycle such as the times when the tool is switched off and when it is running idle in addition to the trigger time).

EC Declaration of Conformity

For European countries only

The EC declaration of conformity is included as Annex A to this instruction manual.

SAFETY WARNINGS

General power tool safety warnings

⚠️WARNING: Read all safety warnings, instructions, illustrations and specifications provided with this power tool. Failure to follow all instructions listed below may result in electric shock, fire and/or serious injury.

Save all warnings and instructions for future reference.

The term "power tool" in the warnings refers to your mains-operated (corded) power tool or battery-operated (cordless) power tool.

CORDLESS SHEAR SAFETY WARNINGS

1. Hold the tool firmly.
2. Secure the workpiece firmly.
3. Keep hands away from moving parts.
4. Edges and chips of the workpiece are sharp. Wear gloves. It is also recommended that you put on thickly bottomed shoes to prevent injury.
5. Do not put the tool on the chips of the workpiece. Otherwise it can cause damage and trouble on the tool.
6. Do not leave the tool running. Operate the tool only when hand-held.
7. Always be sure you have a firm footing. Be sure no one is below when using the tool in high locations.
8. Do not touch the blade or the workpiece immediately after operation. They may be extremely hot and cause burn your skin.
9. Avoid cutting electrical wires. It can cause serious accident by electric shock.
10. Do not use a damaged blade. Before each use, inspect the blades for any damages.
The damaged blades may break and cause an injury.

SAVE THESE INSTRUCTIONS.

⚠️WARNING: DO NOT let comfort or familiarity with product (gained from repeated use) replace strict adherence to safety rules for the subject product. MISUSE or failure to follow the safety rules stated in this instruction manual may cause serious personal injury.

Important safety instructions for battery cartridge

1. Before using battery cartridge, read all instructions and cautionary markings on (1) battery charger, (2) battery, and (3) product using battery.
2. Do not disassemble or tamper with the battery cartridge. It may result in a fire, excessive heat, or explosion.
3. If operating time has become excessively shorter, stop operating immediately. It may result in a risk of overheating, possible burns and even an explosion.
4. If electrolyte gets into your eyes, rinse them out with clear water and seek medical attention right away. It may result in loss of your eyesight.
5. Do not short the battery cartridge:
 - (1) Do not touch the terminals with any conductive material.
 - (2) Avoid storing battery cartridge in a container with other metal objects such as nails, coins, etc.
 - (3) Do not expose battery cartridge to water or rain.
A battery short can cause a large current flow, overheating, possible burns and even a breakdown.
6. Do not store and use the tool and battery cartridge in locations where the temperature may reach or exceed 50 °C (122 °F).
7. Do not incinerate the battery cartridge even if it is severely damaged or is completely worn out. The battery cartridge can explode in a fire.
8. Do not nail, cut, crush, throw, drop the battery cartridge, or hit against a hard object to the battery cartridge. Such conduct may result in a fire, excessive heat, or explosion.
9. Do not use a damaged battery.
10. The contained lithium-ion batteries are subject to the Dangerous Goods Legislation requirements.
For commercial transports e.g. by third parties, forwarding agents, special requirement on packaging and labeling must be observed.
For preparation of the item being shipped, consulting an expert for hazardous material is required. Please also observe possibly more detailed national regulations.
Tape or mask off open contacts and pack up the battery in such a manner that it cannot move around in the packaging.

11. When disposing the battery cartridge, remove it from the tool and dispose of it in a safe place. Follow your local regulations relating to disposal of battery.
12. Use the batteries only with the products specified by Makita. Installing the batteries to non-compliant products may result in a fire, excessive heat, explosion, or leak of electrolyte.
13. If the tool is not used for a long period of time, the battery must be removed from the tool.
14. During and after use, the battery cartridge may take on heat which can cause burns or low temperature burns. Pay attention to the handling of hot battery cartridges.
15. Do not touch the terminal of the tool immediately after use as it may get hot enough to cause burns.
16. Do not allow chips, dust, or soil stuck into the terminals, holes, and grooves of the battery cartridge. It may result in poor performance or breakdown of the tool or battery cartridge.
17. Unless the tool supports the use near high-voltage electrical power lines, do not use the battery cartridge near high-voltage electrical power lines. It may result in a malfunction or breakdown of the tool or battery cartridge.
18. Keep the battery away from children.

SAVE THESE INSTRUCTIONS.

CAUTION: Only use genuine Makita batteries. Use of non-genuine Makita batteries, or batteries that have been altered, may result in the battery bursting causing fires, personal injury and damage. It will also void the Makita warranty for the Makita tool and charger.

Tips for maintaining maximum battery life

1. Charge the battery cartridge before completely discharged. Always stop tool operation and charge the battery cartridge when you notice less tool power.
2. Never recharge a fully charged battery cartridge. Overcharging shortens the battery service life.
3. Charge the battery cartridge with room temperature at 10 °C - 40 °C (50 °F - 104 °F). Let a hot battery cartridge cool down before charging it.
4. When not using the battery cartridge, remove it from the tool or the charger.
5. Charge the battery cartridge if you do not use it for a long period (more than six months).

FUNCTIONAL DESCRIPTION

CAUTION: Always be sure that the tool is switched off and the battery cartridge is removed before adjusting or checking function on the tool.

Installing or removing battery cartridge

CAUTION: Always switch off the tool before installing or removing of the battery cartridge.

CAUTION: Hold the tool and the battery cartridge firmly when installing or removing battery cartridge. Failure to hold the tool and the battery cartridge firmly may cause them to slip off your hands and result in damage to the tool and battery cartridge and a personal injury.

To remove the battery cartridge, slide it from the tool while sliding the button on the front of the cartridge.

To install the battery cartridge, align the tongue on the battery cartridge with the groove in the housing and slip it into place. Insert it all the way until it locks in place with a little click. If you can see the red indicator on the upper side of the button, it is not locked completely.

► Fig.1: 1. Red indicator 2. Button 3. Battery cartridge

CAUTION: Always install the battery cartridge fully until the red indicator cannot be seen. If not, it may accidentally fall out of the tool, causing injury to you or someone around you.

CAUTION: Do not install the battery cartridge forcibly. If the cartridge does not slide in easily, it is not being inserted correctly.

Indicating the remaining battery capacity

Only for battery cartridges with the indicator

► Fig.2: 1. Indicator lamps 2. Check button

Press the check button on the battery cartridge to indicate the remaining battery capacity. The indicator lamps light up for a few seconds.

Indicator lamps			Remaining capacity
Lighted	Off	Blinking	
■	□	◐	75% to 100%
■ ■ ■ ■			50% to 75%
■ ■ □ □			25% to 50%
■ □ □ □			0% to 25%
◐ □ □ □			Charge the battery.
■ ■ □ □			The battery may have malfunctioned.
□ □ ■ ■			

NOTE: Depending on the conditions of use and the ambient temperature, the indication may differ slightly from the actual capacity.

NOTE: The first (far left) indicator lamp will blink when the battery protection system works.

Tool / battery protection system

The tool is equipped with a tool/battery protection system. This system automatically cuts off the power to extend tool and battery life. The tool will automatically stop during operation if the tool or battery is placed under one of the following conditions:

Overload protection

This protection works when the tool is operated in a manner that causes it to draw an abnormally high current. In this situation, turn the tool off and stop the application that caused the tool to become overloaded. Then turn the tool on to restart.

Overheat protection

When the tool or battery is overheated, the tool stops automatically and the lamp blinks. In this case, let the tool and battery cool before turning the tool on again.

Overdischarge protection

This protection works when the remaining battery capacity gets low. In this situation, remove the battery from the tool and charge the battery.

Switch action

CAUTION: Before installing the battery cartridge into the tool, always check to see that the switch trigger actuates properly and returns to the "OFF" position when released.

To prevent the switch trigger from accidentally pulled, the trigger-lock button is provided.

To start the tool, depress the trigger-lock button from "B" side and pull the switch trigger.

Tool speed is increased by increasing pressure on the switch trigger. Release the switch trigger to stop. After use, always press in the trigger-lock button from "A" side.

For continuous operation, pull the switch trigger and then push in the lock button. To stop the tool from the locked position, pull the switch trigger fully to unlock.

► **Fig.3:** 1. Trigger-lock button 2. Switch trigger 3. Lock button

Accidental re-start preventive function

Even if you install the battery cartridge while pulling the switch trigger, the tool does not start.

To start the tool, first release the switch trigger and then pull the switch trigger.

Lighting the lamp

CAUTION: Do not look in the light or see the source of light directly.

To turn on the lamp, slightly pull the switch trigger, and then release it. The lamp goes out approximately 10 seconds after releasing the switch trigger.

► **Fig.4:** 1. Lamp

NOTE: Use a dry cloth to wipe the dirt off the lens of the lamp. Be careful not to scratch the lens of lamp, or it may lower the illumination.

ASSEMBLY

CAUTION: Always be sure that the tool is switched off and the battery cartridge is removed before carrying out any work on the tool.

Removing and installing shear blades

CAUTION: Never remove the blades with bare hands. Wear gloves.

The sharp edge of the blade may cause injury.

Removing cutting head

Use the hex wrench (5/32") to loosen the bolts which secure the cutting head. Pull the cutting head straight out by turning it left and right alternately.

► **Fig.5:** 1. Cutting head 2. Bolt 3. Hex wrench (5/32") 4. Loosen

Removing shear blades

NOTICE: Hold the blades and the sleeve not to fall from the cutting head.

NOTICE: Be careful not to lose the sleeve.

Remove the bolts which hold the blades. Then the blades can be removed easily.

► **Fig.6:** 1. Bolt 2. Side blade L 3. Center blade 4. Side blade R 5. Sleeve

Installing shear blades

Insert the center blade, the side blade L, the side blade R, and the sleeve into the cutting head.

Tighten the bolts. In this process, the bolt heads should be protruding 2 - 3 mm from the cutting head surface. If you tighten the bolts excessively, the cutting head cannot be installed to the tool.

► **Fig.7:** 1. Cutting head 2. Side blade R 3. Center blade 4. Sleeve 5. Sleeve 6. Side blade L 7. Bolt

Installing cutting head

CAUTION: Secure the cutting head firmly. Otherwise the cutting head may rotate during operation and cause serious injury.

Insert the cutting head into the tool by turning it left and right alternately. Then tighten the three bolts in the order of A, B, C with the hex wrench (5/32"). Make sure the bolts are fastened with 5.1 - 5.7 N•m (45 - 50 in•lbs) before using the tool.

► **Fig.8:** 1. Cutting head 2. Bolt 3. Hex wrench (5/32")
4. Tighen

Hook

CAUTION: Never hook the tool at high location or on potentially unstable surface.

► **Fig.9:** 1. Groove 2. Hook 3. Screw

The hook is convenient for temporarily hanging the tool. This can be installed on either side of the tool. To install the hook, insert it into a groove in the tool housing on either side and then secure it with a screw. To remove, loosen the screw and then take it out.

OPERATION

Adjusting shear blade

Adjust the side blade L to prevent the curl of the workpiece from contacting the cutting head and the workpiece. Loosen bolts with the hex wrench (5/32"). Move the side blade L back and forth to adjust it. Then tighten the three bolts with the hex wrench (5/32").

► **Fig.10:** 1. Bolt 2. Side blade L

Lubrication

NOTICE: Use the standard machine oil for steel or the mineral spirits for aluminum.

Before operation, always lubricate the following areas:

- A The cutting area of the workpiece.
- B The part of the center blade which contacts to the workpiece.
- C The both sides of the center blade which contacts to the side blade L and side blade R.

► **Fig.11**

Adjusting cutting head angle

CAUTION: Make sure the cutting head is secured in the position after adjusting the cutting head angle. Otherwise the cutting head may rotate during operation and cause serious injury.

Rotate the cutting head while pushing the rotation button.

Release the rotation button when the cutting head is in the desired angle.

► **Fig.12:** 1. Rotation button

Cutting operation

CAUTION: Wear gloves. Edges and chips of the workpiece are sharp and may cause injury.

Secure the workpiece firmly. Move the tool forward keeping the side blades flush with the workpiece surface.

► **Fig.13:** 1. Side blade 2. Workpiece

MAINTENANCE

CAUTION: Always be sure that the tool is switched off and the battery cartridge is removed before attempting to perform inspection or maintenance.

NOTICE: Never use gasoline, benzine, thinner, alcohol or the like. Discoloration, deformation or cracks may result.

To maintain product SAFETY and RELIABILITY, repairs, any other maintenance or adjustment should be performed by Makita Authorized or Factory Service Centers, always using Makita replacement parts.

OPTIONAL ACCESSORIES

CAUTION: These accessories or attachments are recommended for use with your Makita tool specified in this manual. The use of any other accessories or attachments might present a risk of injury to persons. Only use accessory or attachment for its stated purpose.

If you need any assistance for more details regarding these accessories, ask your local Makita Service Center.

- Hex wrench (5/32")
- Makita genuine battery and charger

NOTE: Some items in the list may be included in the tool package as standard accessories. They may differ from country to country.