

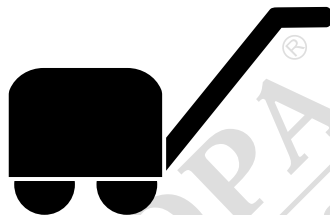

Husqvarna®



LP 6505, LP 7505

EN Operator's manual

2-24



МАГАЗИН
БАШ МАЙСТОРА
ПРОФЕСИОНАЛНИ РЕШЕНИЯ

Contents

Introduction.....	2	Transportation, storage and disposal.....	19
Safety.....	4	Technical data.....	21
Operation.....	9	EC Declaration of Conformity.....	24
Maintenance.....	12		

Introduction

Product overview

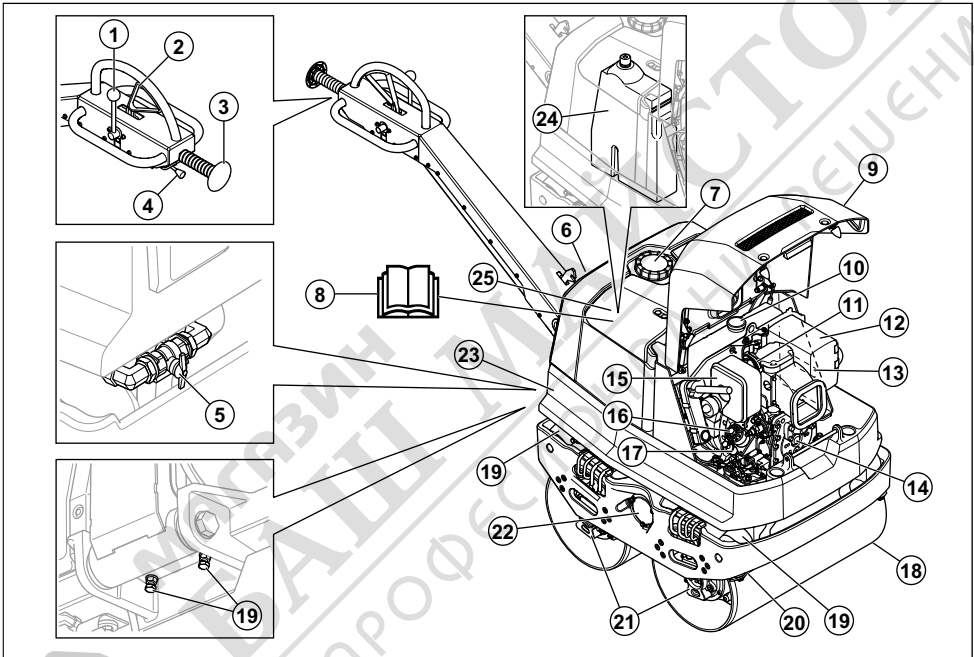

- | | |
|--|-----------------------------|
| 1. Vibration control, ON/OFF | 15. Air filter |
| 2. Control for forward and rearward movement | 16. Engine oil filter |
| 3. Emergency stop button | 17. Engine oil dipstick |
| 4. Throttle control | 18. Drum |
| 5. Water valve | 19. Vibration damping units |
| 6. Control panel | 20. Scraper |
| 7. Water tank | 21. Drum motors |
| 8. Operator's manual | 22. Eccentric element |
| 9. Front cover | 23. Safety frame |
| 10. Fuel tank | 24. Hydraulic oil tank |
| 11. Lever for the decompression valve | 25. Top cover |
| 12. Muffler | |
| 13. Type plate | |
| 14. Connection for the start handle | |

Control panel overview

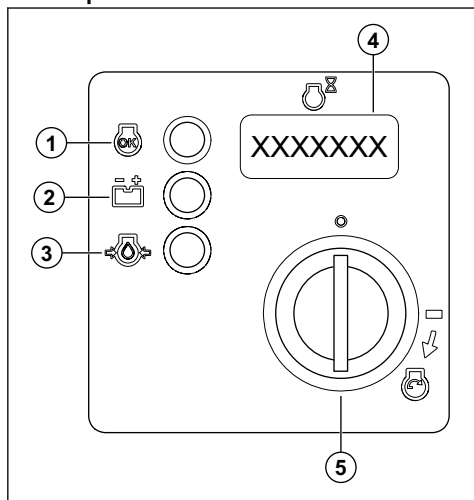

1. Operation indicator. This LED comes on when the engine is on.
2. Error indicator for battery charge. This LED comes on if the battery does not charge correctly.
3. Oil pressure indicator. This LED comes on if the oil pressure is too low.
4. Hour meter. The display shows how many hours the engine has operated.
5. Ignition key.

Product description

The product is a walk-behind double drum roller for compaction of thin layers of granular soils and asphalt. The product has a diesel fuel combustion engine.

Intended use

The product is for professional operation only. Use the product for repairs and maintenance of driveways, paths and parking lots. Do not use the product for other tasks.

Symbols on the product



WARNING: This product can be dangerous and cause serious injury or death to the operator or others. Be careful and use the product correctly.



Read the manual carefully and make sure that you understand the instructions before you use the product.



Use hearing protection.



Use protective boots.



Hydraulic oil level.



Hydraulic oil filter.



Electrical start.



The battery charges.



Hour meter.



Engine oil pressure.



Risk of injury. Keep your hands away from the fan blades and other rotating parts.



Risk of injury if the handle falls on you. Lock the handle in the lifted position.



Hot surface.



Maximum slope angle.



Risk of injury if the product falls down a slope.



The operator must be higher up on the slope than the product.



Lifting point on the safety frame.



Tie-down bracket.



Water nozzle.



Water tank.



Noise emission to the environment as referred to in the EC directive. The emission of the product is specified in *Technical data on page 21* and on the label.



This product is in compliance with applicable EC directives.



Vibration ON/OFF control.



Forward and rearward control.

Note: Other symbols/decals on the product refer to special certification requirements for some markets.

Type plate

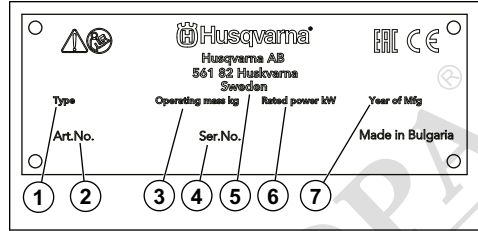

1. Product type
2. Product number
3. Product weight
4. Serial number
5. Manufacturer
6. Rated power
7. Production year

Product liability

As referred to in the product liability laws, we are not liable for damages that our product causes if:

- the product is incorrectly repaired.
- the product is repaired with parts that are not from the manufacturer or not approved by the manufacturer.
- the product has an accessory that is not from the manufacturer or not approved by the manufacturer.
- the product is not repaired at an approved service center or by an approved authority.

Safety

Safety definitions

Warnings, cautions and notes are used to point out specially important parts of the manual.



WARNING: Used if there is a risk of injury or death for the operator or bystanders if the instructions in the manual are not obeyed.



CAUTION: Used if there is a risk of damage to the product, other materials or the adjacent area if the instructions in the manual are not obeyed.

Note: Used to give more information that is necessary in a given situation.

General safety instructions



WARNING: Read the warning instructions that follow before you use the product.

- This product is a dangerous tool if you are not careful or if you use the product incorrectly. This product can cause serious injury or death to the operator or others. Before you use the product, you must read and understand the contents of this operator's manual.
- Save all warnings and instructions.
- Comply with all applicable laws and regulations.
- The operator and the employer of the operator must know and prevent the risks during operation of the product.

- Do not let a person operate the product unless they read and understand the contents of the operator's manual.
- Do not operate the product unless you receive training before use. Make sure that all operators receive training.
- Do not let a child operate the product.
- Only let approved persons operate the product.
- The operator is responsible for accidents that occur to other persons or their property.
- Do not use the product if you are tired, ill, or under the influence of alcohol, drugs or medicine.
- Always be careful and use your common sense.
- This product produces an electromagnetic field during operation. This field can under some circumstances interfere with active or passive medical implants. To decrease the risk of serious injury or death, we recommend persons with medical implants to speak to their physician and the medical implant manufacturer before operating this product.
- Keep the product clean. Make sure that you can clearly read signs and decals.
- Do not use the product if it is defective.
- Do not do modifications to this product.
- Do not operate the product if it is possible that other persons have done modifications to the product.
- Before you go away from the product, stop the engine and make sure that there is no risk of accidental start.
- Make sure that clothes, long hair and jewelry do not get caught in moving parts.
- Do not sit on the product.
- Do not hit the product.
- Always operate the product from behind with your hands on the handle.
- Do not operate the product near electrical cables. The product does not have electrical insulation and injury or death can occur.
- Before you operate the product, find out if there are hidden wires, cables and pipes in the work area. If the product hits a hidden object, stop the engine immediately and examine the product and the object. Do not start to operate the product again until you know that it is safe to continue.

Vibration safety



WARNING: Read the warning instructions that follow before you use the product.

Safety instructions for operation



WARNING: Read the warning instructions that follow before you use the product.

- Make sure that you know how to stop the engine quickly in an emergency.
- The operator must have the physical strength that is necessary to operate the product safely.
- Do not operate the product without all protective covers installed.
- Use personal protective equipment. Refer to *Personal protective equipment on page 6*.
- Make sure that only approved persons are in the work area.
- Keep the work area clean and bright.
- Make sure that you are in a safe and stable position during operation.
- Make sure that there is no risk that you or the product can fall from a height.
- Make sure that there is no grease or oil on the handle.
- Do not use the product in areas where fire or explosions can occur.
- The product can cause objects to eject at high speed. Make sure that all persons in the work area use approved personal protective equipment. Remove loose objects from the work area.
- During operation of the product, vibrations go from the product to the operator. Regular and frequent operation of the product can cause or increase the degree of injuries to the operator. Injuries can occur in fingers, hands, wrists, arms, shoulders, and/or nerves and blood supply or other body parts. The injuries can be debilitating and/or permanent, and can increase gradually during weeks, months or years. Possible injuries include damage to the blood circulation system, the nervous system, joints, and other body structures.
- Symptoms can occur during operation of the product or at other times. If you have symptoms and continue to operate the product, the symptoms can increase or become permanent. If these or other symptoms occur, get medical aid:
 - Numbness, loss of feeling, tingling, pricking, pain, burning, throbbing, stiffness, clumsiness, loss of strength, changes in skin color or condition.
- Symptoms can increase in cold temperatures. Use warm clothing and keep your hands warm and dry when you operate the product in cold environments.
- Do maintenance on and operate the product as given in the operator's manual, to keep a correct vibration level.
- The product has a vibration damping system that decreases the vibrations from the handles to the operator. Let the product do the work. Do not push the product with force. Hold the product at the handles lightly, but make sure that you control the product and operate it safely. Do not push the handles into the end stops more than necessary.

- Keep your hands on the handle or handles only. Keep all other body parts away from the product.
- Stop the product immediately if strong vibrations suddenly occurs. Do not continue the operation before the cause of the increased vibrations is removed.

Dust safety



WARNING: Read the warning instructions that follow before you use the product.

- Operation of the product can cause dust in the air. Dust can cause serious injury and permanent health problems. Silica dust is regulated as harmful by several authorities. These are examples of such health problems:
 - The fatal lung diseases chronic bronchitis, silicosis and pulmonary fibrosis
 - Cancer
 - Birth defects
 - Skin inflammation
- Use correct equipment to decrease the quantity of dust and fumes in the air and to decrease dust on work equipment, surfaces, clothing and body parts. Examples of controls are dust collection systems and water sprays to bind dust. Decrease dust at the source where possible. Make sure that the equipment is correctly installed and used and that regular maintenance is done.
- Use approved respiratory protection. Make sure that the respiratory protection is applicable for the dangerous materials in the work area.
- Make sure that the airflow is sufficient in the work area.
- If it is possible, point the exhaust of the product where it cannot cause dust to go into the air.

Exhaust fumes safety



WARNING: Read the warning instructions that follow before you use the product.

- The exhaust fumes from the engine contain carbon monoxide which is an odourless, poisonous and very dangerous gas. To breathe carbon monoxide can cause death. Because carbon monoxide is odourless and cannot be seen, it is not possible to sense it. A symptom of carbon monoxide poisoning is dizziness, but it is possible that a person becomes unconscious without warning if the quantity or concentration of carbon monoxide is sufficient.
- Exhaust fumes also contain unburned hydrocarbons including benzene. Long-term inhalation can cause health problems.
- Exhaust fumes that you can see or smell also contain carbon monoxide.

- Do not use a combustion engine product indoors or in areas that do not have sufficient airflow.
- Do not breathe the exhaust fumes.
- Make sure that the airflow in the work area is sufficient. This is very important when you operate the product in trenches or other small work areas where exhaust fumes can easily collect.

Noise safety



WARNING: Read the warning instructions that follow before you use the product.

- High noise levels and long-term exposure to noise can cause noise-induced hearing loss.
- To keep the noise level to a minimum, do maintenance on and operate the product as given in the operator's manual.
- Examine the muffler for damages and defects. Make sure that the muffler is correctly attached to the product.
- Use approved hearing protection while you operate the product.
- Listen for warning signals and voices when you use hearing protection. Remove the hearing protection when the product is stopped, unless hearing protection is necessary for the noise level in the work area.

Personal protective equipment



WARNING: Read the warning instructions that follow before you use the product.

- Always use approved personal protective equipment when you operate the product. Personal protective equipment cannot fully prevent injury but it decreases the degree of injury if an accident does occur. Let your dealer help you select the correct personal protective equipment.
- Regularly do a check of the condition of the personal protective equipment.
- Use an approved protective helmet.
- Use approved hearing protection.
- Use approved respiratory protection.
- Use approved eye protection with side protection.
- Use protective gloves.
- Use boots with steel toe-cap and non-slip sole.
- Use approved work clothing or equivalent close-fitting clothing that has long sleeves and long legs.

Fire extinguisher

- Keep a fire extinguisher near during operation.
- Use a powder fire extinguisher of "ABE" class or a carbon dioxide fire extinguisher of "BE" type.

Safety devices on the product



WARNING: Read the warning instructions that follow before you use the product.

- Do not use a product with defective safety devices.
- Do a check of the safety devices regularly. If the safety devices are defective, speak to your Husqvarna service agent.

Muffler

The muffler keeps the noise levels to a minimum and sends the exhaust fumes away from the operator.

Do not use the product if the muffler is missing or defective. A defective muffler increases the noise level and the risk of fire.



WARNING: The muffler becomes very hot during and after use and when the engine operates at idle speed. Be careful near flammable materials and/or fumes to prevent fire.

To do a check of the muffler

- Examine the muffler regularly to make sure that it is attached correctly and not damaged.

Safety frame

The safety frame prevents damage to the product if it falls.

To do a check of the safety frame

- Make sure that there are no cracks or other damages on the safety frame.
- Make sure that the safety frame is correctly installed on the product.

Vibration damping units

The vibration damping units decrease vibration in the product. The vibration damping units decrease harmful vibrations to prevent injury to the operator and damage to the product.

To do a check of the vibration damping units

There are 6 vibration damping units on the product. 2 vibration damping units are on the left side, 2 on the right side and 2 at the bottom of the handle.

- Make sure that the vibration damping units are correctly installed.
- Examine the vibration damping units for damages and wear.
- Replace the vibration damping units if it is necessary.

Emergency stop button

The emergency stop button is used to quickly stop the movement of the product.

To do a check of the emergency stop button

1. Move the control for forward and rearward movement (A) to start the movement of the product.

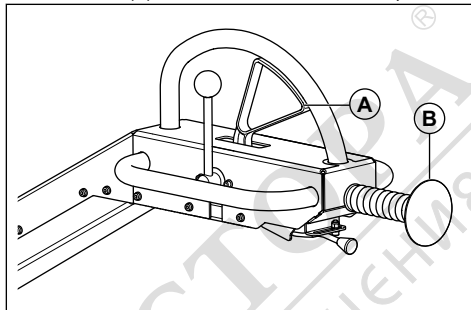

2. Push the emergency stop button (B).
3. Make sure that the product stops.
4. Make sure that the emergency stop button goes back to its initial position.

Fuel safety



WARNING: Read the warning instructions that follow before you use the product.

- Fuel is flammable and the fumes are explosive. Be careful with fuel to prevent injury, fire and explosion.
- Do not breathe in the fuel fumes. The fuel fumes are poisonous and can cause injury. Make sure that the airflow is sufficient.
- Do not remove the fuel tank cap or fill the fuel tank when the engine is on.
- Let the engine become cool before you refuel.
- Do not fill fuel in an indoor area. Not sufficient airflow can cause injury or death because of asphyxiation or carbon monoxide.
- Do not smoke near the fuel or the engine.
- Do not put hot objects near the fuel or the engine.
- Do not fill fuel near sparks or flames.
- Before you refuel, open the fuel tank cap slowly and release the pressure carefully.
- Fuel on your skin can cause injury. If you get fuel on your skin, use soap and water to remove the fuel.
- If you spill fuel on your clothing, change clothing immediately.
- Do not fill the fuel tank fully. Heat causes the fuel to expand. Keep a space at the top of the fuel tank.
- Tighten the fuel tank cap fully. If the fuel tank cap is not tightened, there is a risk of fire.

- Before you start the product, move the product to a minimum of 3 m/10 ft from where you refueled.
- Do not start the product if there is fuel or engine oil on the product. Remove the unwanted fuel and engine oil and let the product dry before you start the engine.
- Examine the engine for leaks regularly. If there are leaks in the fuel system, do not start the engine until the leaks are repaired.
- Do not use your fingers to examine the engine for leaks.
- Keep fuel in approved containers only.
- When the product and fuel is in storage, make sure that fuel and fuel fumes cannot cause damage.
- Drain the fuel in an approved container outdoors and away from sparks and flames.

Battery safety



WARNING: A damaged battery can cause an explosion and cause injury. If the battery has a deformation or is damaged, speak to an approved Husqvarna service agent.



WARNING: Read the warning instructions that follow before you use the product.

- Use protective glasses when you are near batteries.
- Do not wear watches, jewelry or other metal objects near the battery.
- Keep the battery out of reach for children.
- Charge the battery in a space with good airflow.
- Keep flammable materials at a minimum clearance of 1 m when you charge the battery.
- Discard replaced batteries. See *Disposal on page 20*.
- Explosive gases can come from the battery. Do not smoke near the battery. Keep the battery away from open flames and sparks.

Safety instructions for operation on slopes



WARNING: Read the warning instructions that follow before you use the product.

- Make sure that the work area is safe. Be very careful on slopes and rough surfaces. Wet and loose soil increases the risk of an accident.
- Make sure that all persons in the work area are above the product on the slope.
- Operate the product up and down the slope, not from side to side.
- The maximum slope angle is 17° in these conditions:
 - The product is stationary on a hard flat surface with its side in direction of the slope.
 - The vibration is OFF.

- All tanks are full.
- The maximum slope angle is 19° in these conditions:
 - The product is stationary on a hard flat surface with its front in direction of the slope.
 - The vibration is OFF.
 - All tanks are full.
- The maximum slope angle is 14° in these conditions:
 - The product moves.
 - The vibration is ON.
- Loose ground, vibrations and the operation speed can cause the product to fall on a slope with a smaller angle.
- Do not park the product on a slope. If you must park the product on a slope, make sure that the product cannot fall. There is a risk of injury and damage.

Safety instructions for operation near edges



WARNING: Read the warning instructions that follow before you use the product.

- There is a risk that the product falls when you operate it near an edge. Always keep a minimum of $\frac{2}{3}$ of the product on a surface that is sufficiently stable to hold the product weight.
- If the product falls, stop the engine before you lift the product back to a surface that is sufficiently stable. Refer to *To lift the product on page 19*.

Safety instructions for maintenance



WARNING: Read the warning instructions that follow before you use the product.

- If the maintenance is not done correctly and regularly, the risk of injury and damage to the product increases.
- Use personal protective equipment. Refer to *Personal protective equipment on page 6*.
- Stop the engine and make sure that all parts of the product are cool before you do the maintenance.
- Clean the product to remove dangerous material before you do the maintenance.
- Disconnect the spark plug cap before you do the maintenance.
- The exhaust fumes from the engine are hot and can contain sparks. Do not operate the product in indoor areas or near flammable material.
- Do not change the product. Modifications that are not approved by the manufacturer, can cause serious injury or death.
- Always use original accessories and spare parts. Accessories and spare parts that are not approved by the manufacturer, can cause serious injury or death.
- Replace damaged, worn or broken parts.

- Only do the maintenance as given in this operator's manual. Let an approved service center do all other servicing.
- Remove all tools from the product before you start the engine after maintenance. Loose tools or tools attached to rotating parts can eject and cause injury.
- After maintenance, do a check of the vibration level in the product. If it is not correct, speak to an approved service center.
- Let an approved service center do servicing on the product regularly.

Operation

Introduction



WARNING: Read and understand the safety chapter before you use the product.

To do before you operate the product

- Read the operator's manual carefully and make sure that you understand the instructions.
- Read the engine manual that is supplied by the engine manufacturer.
- Do the daily maintenance. Refer to *Maintenance schedule on page 12*.

To set the handle to operation position



WARNING: Hold the handle tightly when you change the position of the handle. There is a risk of injury if the handle falls on you.

1. Hold the handle.
2. Release the lock lever and lower the handle carefully.

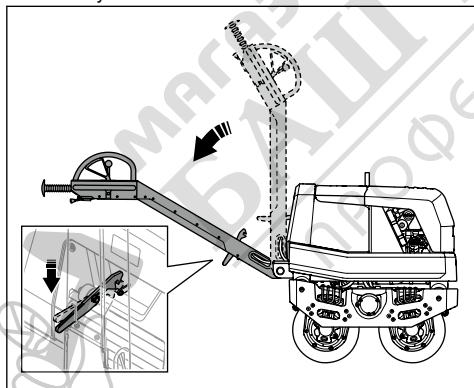

To adjust the handle height

- Adjust the handle height with the vibration damping units for the handle.

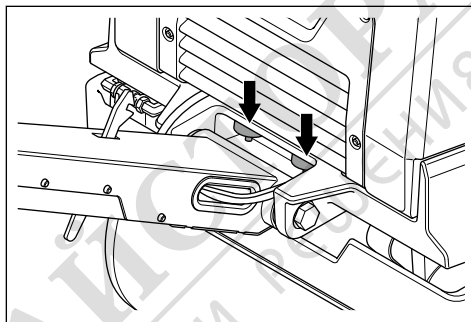

- a) Turn the screws for the vibration damping units to adjust the handle height.

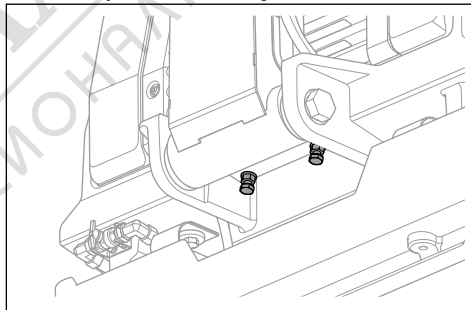

CAUTION: Adjust the screws to the same height to make sure that the load on the handle is balanced.

To start the product manually

Do this procedure if the product has an engine with manual start.

1. Make sure that the control for forward and rearward movement (A) is in the neutral position.

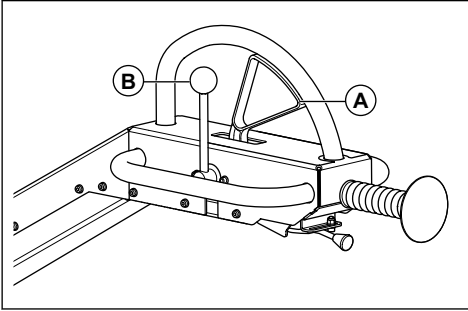

2. Make sure that the vibration control (B) is in the OFF position.
3. Set the throttle control to idle speed.

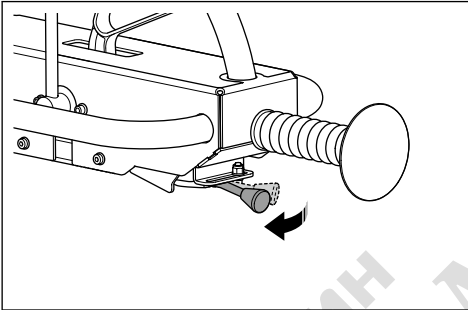

4. Pull the lever for the decompression valve to the start position.

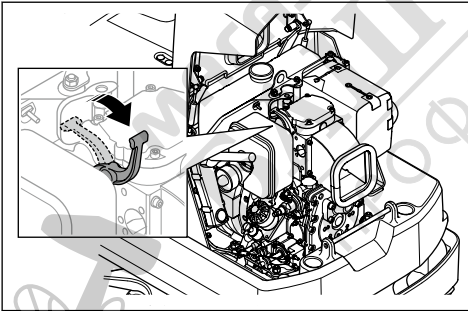

5. Remove the start handle from the transport position (A) and put it in the connection for the start handle (B).

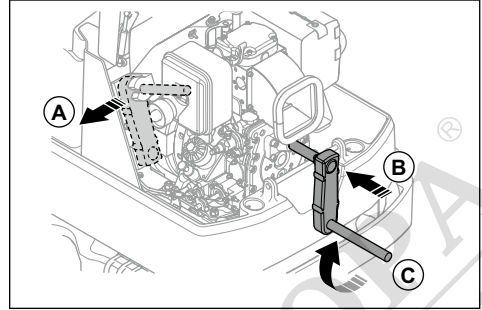

6. Turn the start handle (C) clockwise until the engine starts.
7. Let the engine operate at idle speed for 2-3 minutes.
8. Set the throttle control to full throttle.

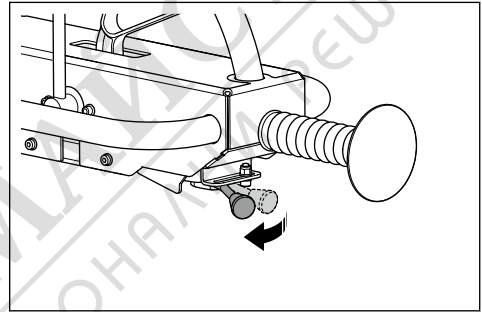

To start the product with electrical start

Do this procedure if the product has an engine with electrical start.

1. Make sure that the control for forward and rearward movement (A) is in the neutral position.

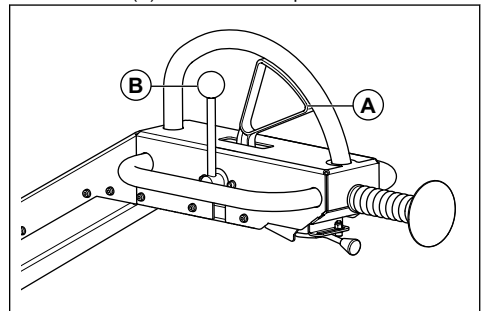

2. Make sure that the vibration control (B) is in the OFF position.

3. Set the throttle control to idle speed.

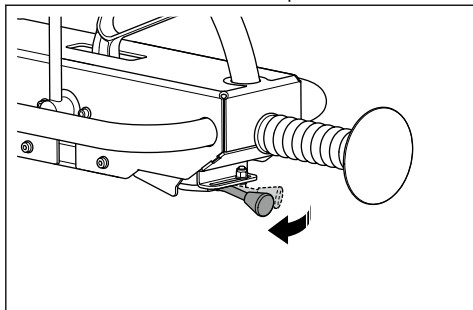

4. Turn the ignition key to the ignition position (A). The indicators for battery charge and oil pressure come on.

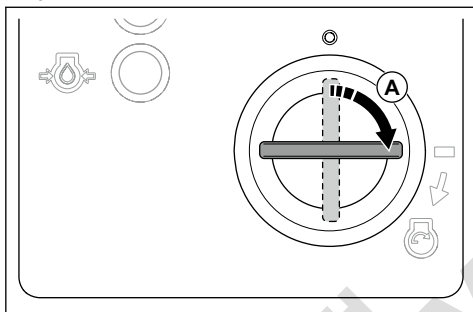

5. Turn the ignition key to the start position (B).

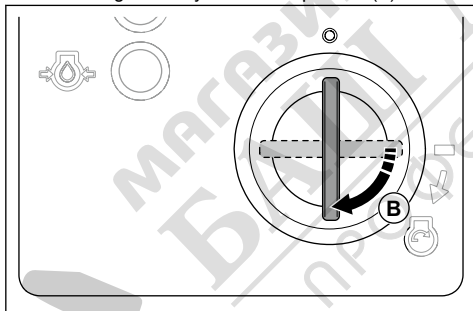

- When the engine starts, immediately release the ignition key. The ignition key goes to the neutral position.
- If the engine does not start in 10 seconds, release the ignition key and wait 5 seconds before you try again.

6. Let the engine operate at idle speed for 2–3 minutes.

7. Set the throttle control to full throttle.

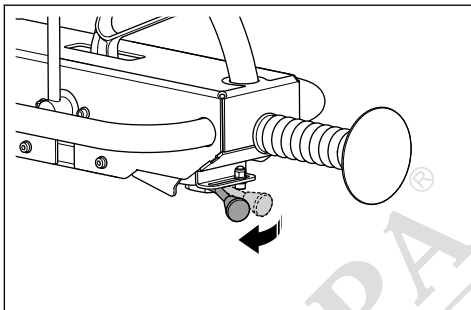

To operate the product

Always operate the product with the throttle control set to full throttle.

- To operate the product forward, move the control for forward and rearward movement (A) forward.

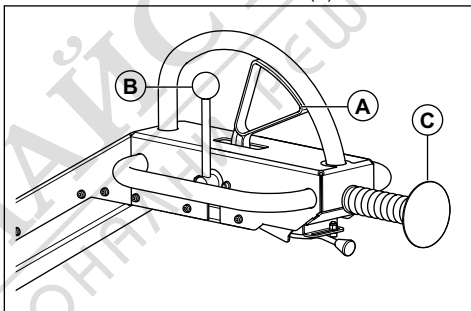

- To operate the product rearward, move the control for forward and rearward movement (A) rearward.
- To start the vibration, move the vibration control (B) to the ON position.
- To stop the movement of the product, release the control for forward and rearward movement.
- To stop the movement of the product in an emergency, push the emergency stop button (C).

Note: The movement stops also if the control for forward and rearward movement is in the forward or rearward position.

To stop the product

- Park the product on level ground.

2. Set the throttle control to idle speed.

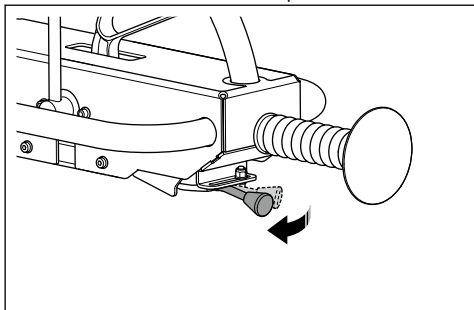

3. Let the engine operate at idle speed for 2–3 minutes.

4. Set the throttle control to the stop position.

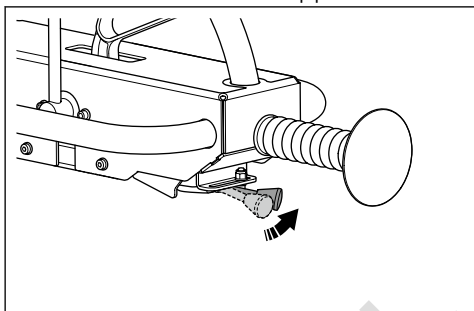

5. If the engine has an electrical start, do also these steps:

a) Turn the ignition key to the stop position (A).

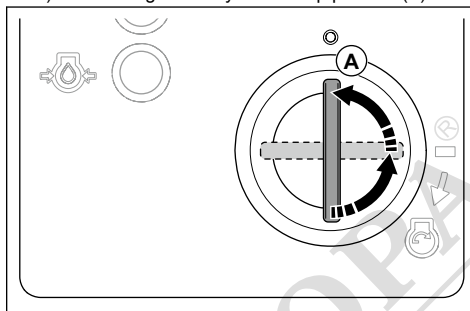

b) Remove the ignition key to prevent accidental start.

The hydraulic parking brake automatically engages when the engine stops.

Maintenance

Introduction



WARNING: Read and understand the safety chapter before you do maintenance on the product.

X = The instructions are given in this operator's manual.

O = Refer to the instructions in the engine manual supplied by the engine manufacturer.

Maintenance schedule

* = General maintenance done by the operator. The instructions are not given in this operator's manual.

General product maintenance	Before use, each 10 h	Weekly, each 100 h	Monthly, each 250 h	Yearly, each 500 h
Make sure that there are no fuel or oil leaks.	*			
Clean the product.	X			
Make sure that nuts and screws are tightened.	*			
Examine the throttle control and the control for forward and rearward movement for damage.	*			
Make sure that the throttle control and the control for forward and rearward movement can move smoothly.	*			
Lubricate the controls and linkages.	*			

General product maintenance	Before use, each 10 h	Weekly, each 100 h	Monthly, each 250 h	Yearly, each 500 h
Examine the safety straps for damage. Replace if it is necessary.	X			
Examine the vibration damping units for damage.	X			
Make sure that the scrapers do not touch the drums. Adjust the clearance if it is necessary.	X			⊕
Fill the water tank with clean water.	*			
Examine all rubber hoses and rubber elements for damage. Replace if it is necessary.	X		X	X
Do a check of the hydraulic oil level.	X			
Do a check of the battery.			X	X
Replace the oil in the eccentric element.				X
Examine and clean the hydraulic oil cooler.			O	
Replace the hydraulic oil.				X

Engine maintenance	Before use, each 10 h	After the first 20 h	Each 250 h	Yearly, each 500 h
Do a check of the fuel level and the engine oil level.	X			
Clean the cooling system of the engine.	O		O	O
Examine the air filter indicator. Clean the air filter if it is necessary.	X	X		
Replace the air filter.			X	X
Do a check of the water separator. Drain the water separator if it is necessary.	X			
Replace the engine oil.		X	X	X
Drain and clean the fuel tank and replace the fuel filter.				O
Adjust the valve head clearance for the air intake and the exhaust valves.		O	O	O
Replace the oil filter.		O	O	O
Do a check of the fuel injection pump.				O
Do a check of the fuel injection nozzle.				O
Drain water from the fuel system.				O

To clean the product



CAUTION: Before you clean the product, attach a plastic bag tightly around the fuel tank cap. This is to make sure that water does not go into the venthole in the fuel tank cap.

- Use running water from a hose or a high-pressure washer to clean the product.



CAUTION: Do not point the water directly at the fuel tank cap, electrical components or the engine.

- Remove grease and oil from the handle.

To do a check of the scrapers

1. Make sure that the scraper blades (A) do not touch the drums.

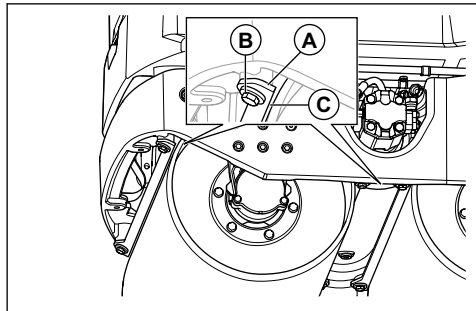

2. If it is necessary, adjust the screws (B) until the clearance (C) is 1.5 mm/0.06 in.

To do a check of the safety straps

1. Examine the safety straps at the front and the rear of the product.

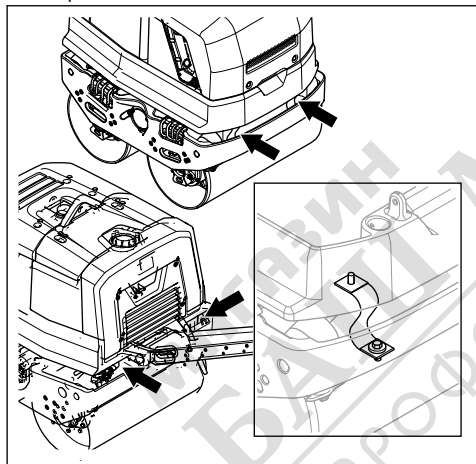

2. Examine the screws and nuts on the safety straps.
3. Replace damaged safety straps.
4. Replace damaged nuts and screws.
5. Tighten loose screws and nuts.

To do a check of the engine oil level

1. Remove the oil tank cap and dipstick.
2. Clean the oil from the dipstick.
3. Put the dipstick back fully into the oil tank.
4. Remove the dipstick.
5. Examine the oil level on the dipstick.

6. If the oil level is low, fill with engine oil and do a check of the oil level again. Refer to *Technical data on page 21* or the engine manual for the correct type of oil.

To replace the engine oil and oil filter

If the engine is cold, start the engine for 1–2 minutes before you drain the engine oil. This makes the engine oil warm and easier to drain.



WARNING: Engine oil is very hot directly after the engine stops. Let the engine become cool before you drain the engine oil. If you spill engine oil on your skin, clean with soap and water.

1. Put a container of sufficient volume below the drain plug for the engine oil. Refer to *Technical data on page 21* for the engine oil volume for your product model.
2. Remove the oil drain hose from the storage position near the engine.
3. Remove the oil drain plug (A) and remove the end plug from the oil drain hose (B).
 - a) LP 6505:

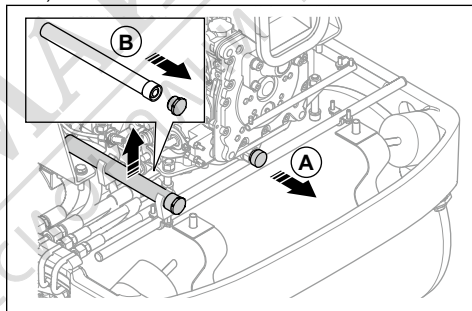

- b) LP 7505:

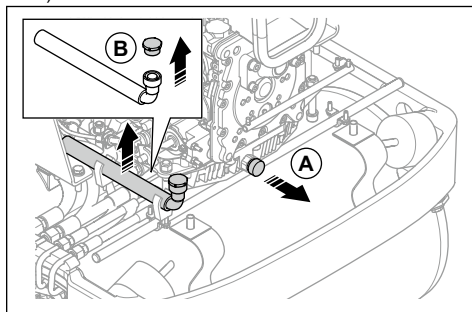

4. Install the oil drain hose and let the oil run out into the container.

a) LP 6505:

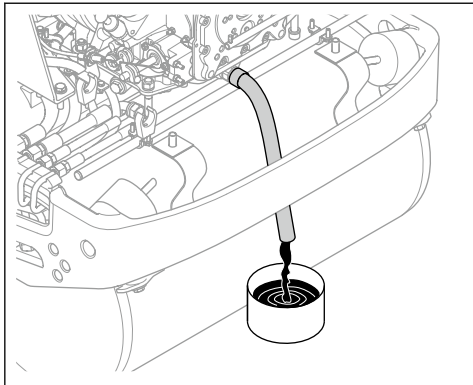

b) LP 7505:

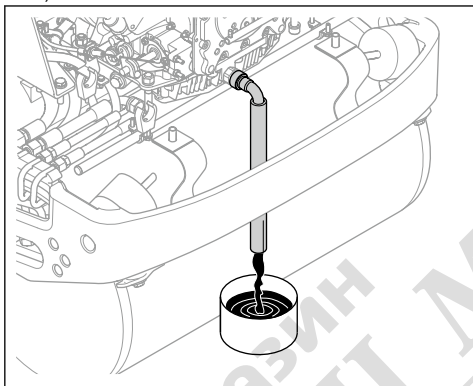

5. Remove the oil drain hose, install the end plug and put the oil drain hose in the storage position near the engine.
6. Install the oil drain plug and tighten it. Make sure that there is no leakage.
7. Replace the oil filter (A).

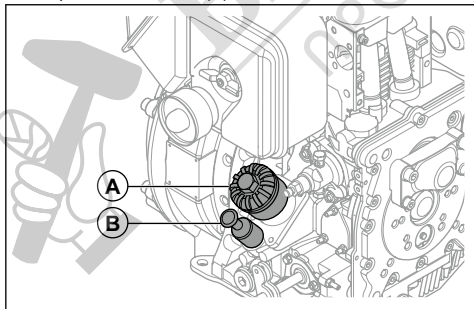

8. Remove the dipstick (B) and fill with new engine oil. Refer to the engine manual for the correct type of oil.
9. Do a check of the engine oil level.

To drain the water separator

1. Remove the drain plug for the water separator.

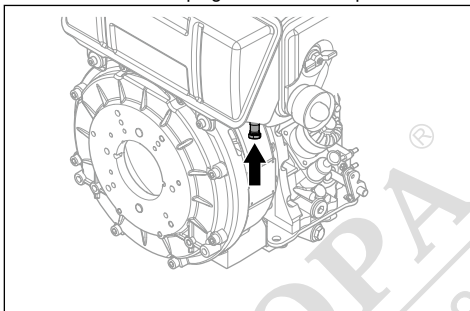

2. Drain until there is only clean fuel in the bowl.
3. Install the drain plug.
4. Discard the water as chemical waste. Refer to *Disposal* on page 20.

Air filter



WARNING: Use approved respiratory protection when you clean or replace the air filter. Discard used air filters correctly. The dust in the air filter is dangerous to your health.



CAUTION: Always replace a damaged air filter, or the dust will go into the engine and cause engine damage.

To examine the air filter indicator



CAUTION: Examine the air filter indicator each time the engine is started. A clogged air filter can cause damage to the product.

1. Examine the air filter indicator.

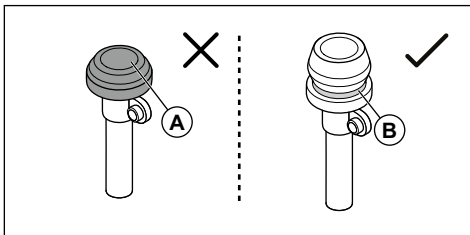

- a) If the air filter indicator is compressed (A), clean or replace the air filter. Refer to *To clean or replace the air filter* on page 16.



WARNING: Stop the engine before you do the maintenance.

- a) If the green mark (B) shows, no maintenance on the air filter is necessary.

Refer to the engine manual for more information about the air filter indicator.

To clean or replace the air filter



WARNING: Use approved respiratory protection when you clean or replace the air filter. Discard used air filters correctly. The dust in the air filter is dangerous to your health.



WARNING: Do not clean the air filter with compressed air. This causes damage to the air filter and the risk increases that you breathe the dangerous dust.

1. Remove the air filter cover.

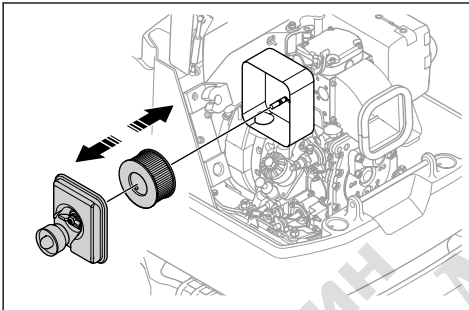

2. Remove the air filter from the air filter housing.
3. Clean the air filter housing with a brush.
4. Tap the air filter against a hard surface or use a vacuum cleaner to remove the particles.



CAUTION: Do not let the nozzle of the vacuum cleaner touch the surface of the paper filter element. Keep a small distance. The sensitive surface of the paper filter element becomes damaged if objects touch it.

5. Examine the air filter for damage.
6. Discard the air filter if it is damaged, wet or if there is oil on it.



CAUTION: Always replace a damaged air filter, or the dust will go into the engine and cause engine damage.

7. Install the clean air filter or a new air filter into the air filter housing.
8. Install the air filter cover.

To replace the oil in the eccentric element

1. Put an applicable container below the eccentric element.
 - a) For model LP 6505, make sure that the container is a minimum of 0.6 l/qts.
 - b) For model LP 7505, make sure that the container is a minimum of 0.9 l/qts.
2. Remove the oil drain plug for the eccentric element.

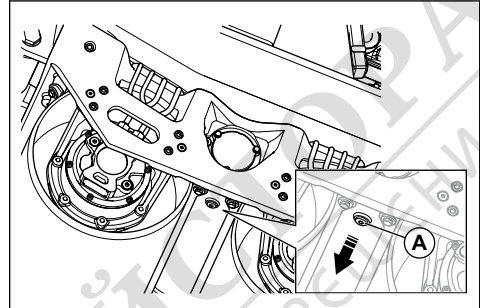

3. Let the oil run out into the container.
4. Clean the surfaces around the hole for the oil drain plug, the threads of the hole and the oil drain plug. Use a dry cloth and, if it is necessary, an applicable solvent.



CAUTION: Do not use water to clean around and on the oil drain plug.

5. Install the oil drain plug.
6. Remove the oil fill plug (B) and the oil level plug (C).

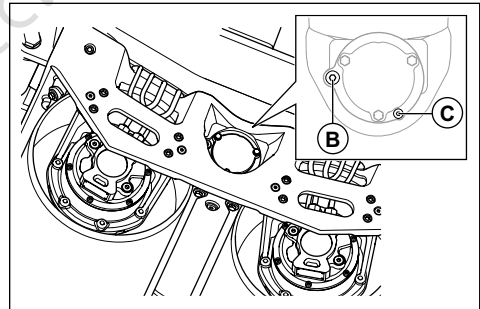

7. Fill the eccentric element with oil until the oil starts to come out of the hole for the oil level plug (C). Refer to *Technical data on page 21* for correct quantity and type of oil.
8. Install the oil level plug (C).
9. Install the oil fill plug (B).

To replace the fuel filter



WARNING: Use protective gloves to prevent skin irritation. Fuel can come from the fuel filter and onto your skin.

1. Disconnect the hose from the top and the bottom of the fuel filter.

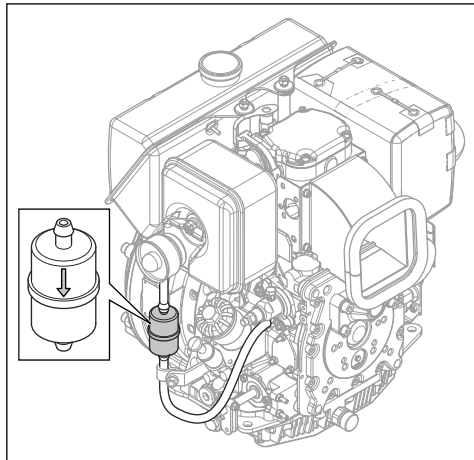

2. Install a new fuel filter. Make sure that the arrow on the fuel filter agrees with the direction of the fuel flow.

Refer to the engine manual for more information.

To do a check of the battery

1. Disconnect the battery cables.
2. Examine the battery for damages. Replace the battery if it is damaged.
3. Clean the battery terminals and the battery cable connectors.
4. Lubricate the battery terminals and the battery cable connectors with grease that does not contain acid.
5. Connect the battery cables.
6. Make sure that the battery is correctly attached.

To charge the battery

- If the battery is not used for a long period of time, charge it fully before you use it.
- Use a battery charger that automatically adjusts the voltage. We recommend a 2-stage charger with constant voltage that automatically decreases to trickle charging when the battery is fully charged. Speak to your Husqvarna dealer for information about the correct battery charger.
- Do a trickle charging 1-2 times during the winter season when the product is in storage.

Hydraulic system

To do a check of the hydraulic hoses

- Examine the hydraulic hoses regularly. Replace worn or damaged hydraulic hoses.



WARNING: Hydraulic oil is dangerous. The rubber in the hydraulic hoses wears with time. Worn or damaged hydraulic hoses can break and the hydraulic oil can cause injury. If you cannot tell if the hydraulic hoses are worn, always replace the hydraulic hoses.

To do a check of the hydraulic oil level

1. Read the hydraulic oil level on the hydraulic oil tank.

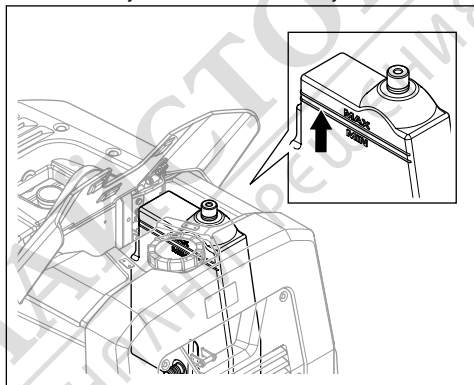

2. If the hydraulic oil level is too low, it is necessary to replace the hydraulic oil. Refer to *To replace the hydraulic oil on page 17*.

To replace the hydraulic oil



WARNING: There is a risk of burn injury. The hydraulic oil becomes hot during operation of the product. Let the product become cool before you replace the hydraulic oil.

1. Remove the oil tank cap, the breather filter and the splash guard from the hydraulic oil tank.

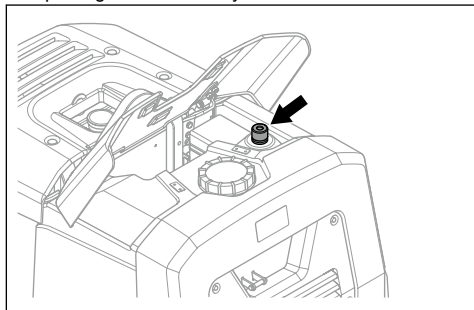

2. Use an oil drain pump to drain the hydraulic oil from the hydraulic oil tank.
3. Clean the opening of the hydraulic oil tank.
4. Replace the breather filter.
5. Fill with hydraulic oil of the correct type. Refer to *Technical data on page 21*.
6. Read the hydraulic oil level on the hydraulic oil tank.

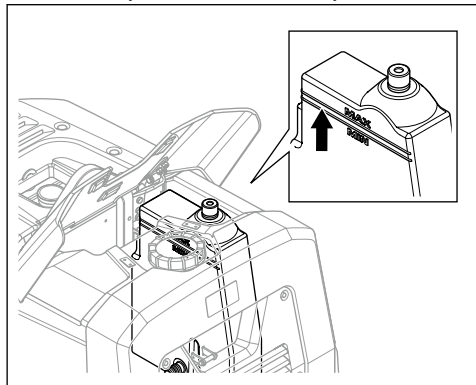

7. Install the oil tank cap, the breather filter and the splash guard.
8. Start the engine and let it operate at idle speed for 2–3 minutes.
9. Read the hydraulic oil level on the hydraulic oil tank again.
10. Fill with hydraulic oil if it is necessary.

To replace the hydraulic oil filter

1. Clean the area around the cover (A) for the hydraulic oil filter.

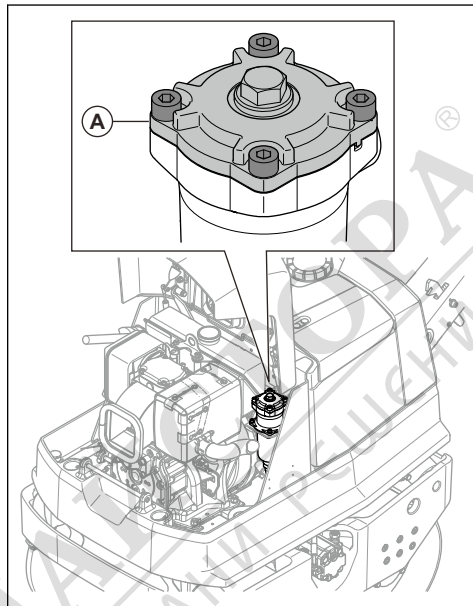

2. Remove the 4 screws and the cover for the hydraulic oil filter.
3. Remove the hydraulic oil filter (B) and remove the spacer (C) from the hydraulic oil filter.

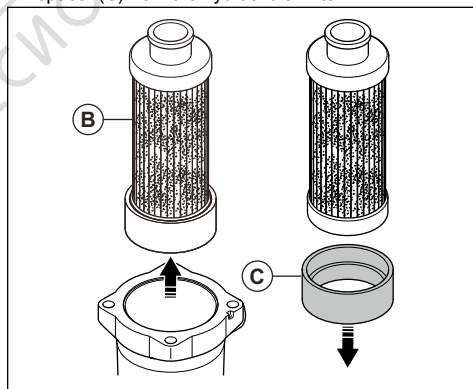

4. Discard the hydraulic oil filter as chemical waste. Refer to *Disposal on page 20*.

5. Install the spacer (C) to a new hydraulic oil filter (D).

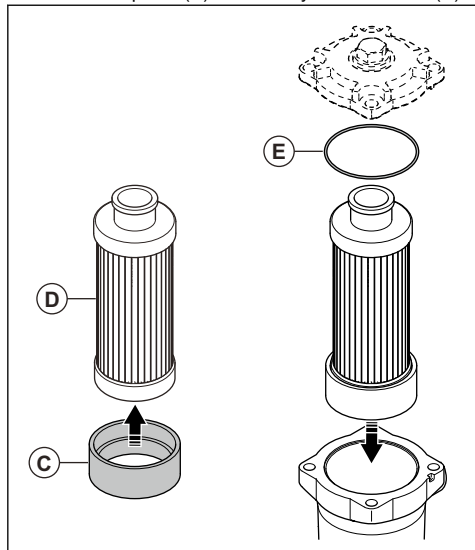

6. Examine the O-ring (E). Replace it if it is damaged.

7. Install the cover for the hydraulic oil filter. Make sure that the cover is installed correctly in the notch.

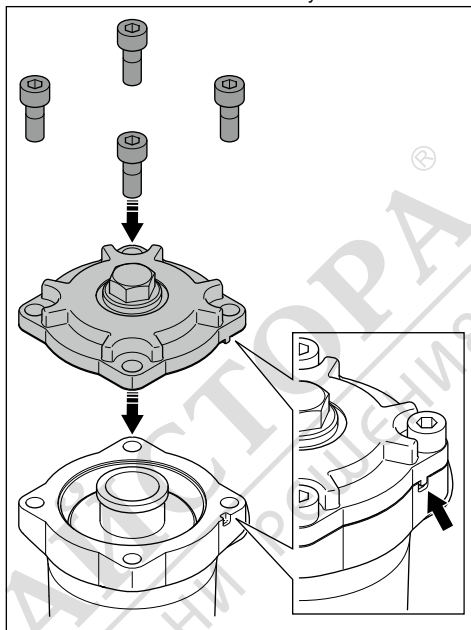

8. Make sure that there is no leakage.

Transportation, storage and disposal

Transportation



WARNING: Be careful during transportation. The product is heavy and can cause injury or damage if it falls or moves during transportation.

Lift the product to move it shorter distances. For longer distances, put the product on a transportation vehicle.



CAUTION: Do not tow the product behind a vehicle.

To lift the product



WARNING: Make sure that the lifting equipment has the correct specification to lift the product safely. The type plate on the product shows the product weight.



WARNING: Do not lift a damaged product. Make sure that the lifting eye, the vibration damping units and the safety straps are correctly installed and not damaged.



WARNING: Do not lift the product at the lifting eye on the engine. Lift the product at the lifting eye on the safety frame only.



WARNING: Do not walk or stay below or near a lifted product.

1. Lock the handle in upright position.

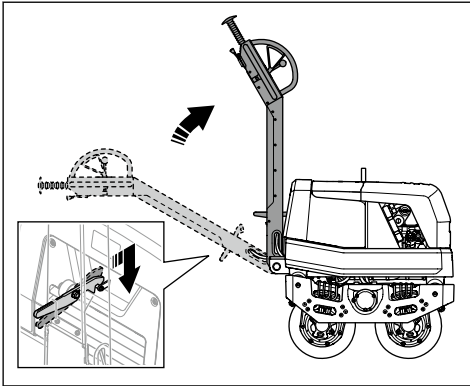

2. Make sure that the lifting eye (A), the vibration damping units (B) and the safety straps (C) are correctly installed and not damaged.

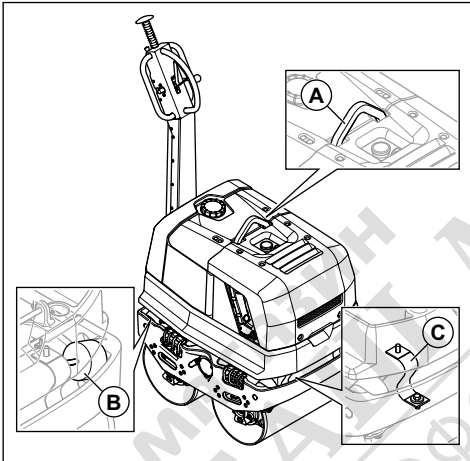

3. Attach the lifting equipment to the lifting eye.

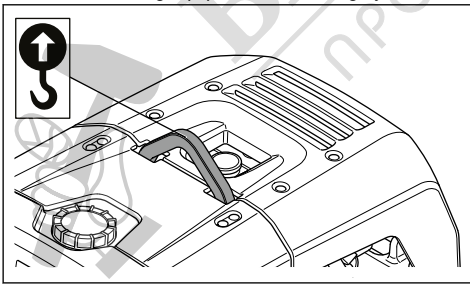

WARNING: Do not use metal hooks, chains or other lifting equipment with

rough edges that can cause damage to the lifting eye.

To safety the product to a transportation vehicle with tie-down straps

1. Lock the handle in upright position.
2. Put straps at the tie-down brackets, 2 on each side of the product, and attach the straps to the vehicle.

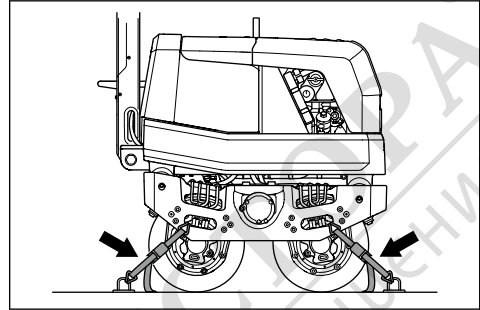

Storage

- Remove all fuel from the fuel tank before you put the product in storage for a long period of time. Discard the fuel at an applicable disposal location.
- Drain the water tank before storage.
- Fully charge the battery before storage. An empty battery freezes at approximately $-7^{\circ}\text{C}/19^{\circ}\text{F}$. A fully charged battery freezes at approximately $-67^{\circ}\text{C}/89^{\circ}\text{F}$.
- Clean the product before storage. Remove oil and dust from the rubber parts.
- Clean the air filter before storage.
- Put a protective cover on the product.
- Keep the product in a dry and frost free area.
- Keep the product in a locked area to prevent access for children or persons that are not approved.

Disposal

- Chemicals can be dangerous and must not be discarded on the ground. Always discard used chemicals at a service center or an applicable disposal location.
- When the product is worn out, send it to the dealer or to an applicable recycling location.
- Oil, oil filters, fuel and the battery can have negative effects on the environment. Obey the local recycling requirements and applicable regulations.
- Do not discard the battery as domestic waste.
- Send the battery to a Husqvarna service agent or discard it at a disposal location for used batteries.

Technical data

Technical data

	LP 6505	LP 7505
Net weight, manual start, kg/lb	716/1579	952/2099
Net weight, electrical start, kg/lb	736/1623	972/2143
Operation weight (EN500, incl. oil, ½ fuel), manual start, kg/lb	745/1642	981/2163
Operation weight (EN500, incl. oil, ½ fuel), electrical start, kg/lb	765/1687	1001/2207
Engine brand/type	Hatz/1D42S	Hatz/1D50S
Engine power, kW/hp @rpm ¹	6.6/8.6 @3000	7.5/10.1 @3000
Vibration frequency, Hz/rpm	58/3480	57/3420
Amplitude, mm/in.	0.52/0.020	0.54/0.021
Static linear load, manual start, kg/cm or pli	5.73 or 32.1	6.54 or 36.6
Static linear load, electrical start, kg/cm or pli	5.88 or 33	6.67 or 37.4
Centrifugal force, kN/lbf	21.8/4900	27.3/6137
Operation speed, m/min or ft./min	0-3.6 or 0-2.3	0-3.6 or 0-2.3
Max. tilt, degrees/%	17/30	17/30
Gradeability with vibration, degrees/%	14/25	14/25
Gradeability without vibration, degrees/%	19/35	19/35
Fuel tank capacity, l/qt	5.0/5.25	5.0/5.25
Crank case, l/qt	1.2/1.27	1.5/1.59
Hydraulic oil, l/qt	12.5/13.2	12.5/13.2
Eccentric element, l/qt	0.6/0.63	0.9/0.95
Water tank, l/gal	58/12.75	58/12.75
Fuel consumption, l/h or qt/h	1.35 or 1.43	1.35 or 1.43
Engine oil	Shell Rimula R4 L 15W-40	Shell Rimula R4 L 15W-40
Eccentric element oil	Shell Rimula R4 L 15W-40	Shell Rimula R4 L 15W-40
Hydraulic fluid	Shell Tellus S2 V68	Shell Tellus S2 V68
Fuel	Ultra-low-sulfur diesel fuel only	Ultra-low-sulfur diesel fuel only

¹ As specified by the engine manufacturer. The power rating of the engine indicated is the average net output (at specified rpm) of a typical production engine for the engine model measured to SAE standard J1349/ISO1585. Mass production engines may differ from this value. Actual power output for the engine installed on the final product will depend on the operating speed, environmental conditions and other values.

Noise and vibration emissions	LP 6505	LP 7505
Sound power level, measured dB (A)	105	106
Sound power level, guaranteed L_{WA} dB (A) ²	107	107
Sound pressure level at the operator's ear, L_p , dB (A) ³	88	88
Vibration level, a_{HV} , m/s^2 , ⁴	4.0	2.6

Noise and vibration declaration statement

These declared values were obtained by laboratory type testing in accordance with the stated directive or standards and are suitable for comparison with the declared values of other products tested in accordance with the same directive or standards. These declared values are not suitable for use in risk assessments and values measured in individual work places may be higher. The actual exposure values and risk of harm experienced by an individual user are unique and depend upon the way the user works, in what material the product is used, as well as upon the exposure time and the physical condition of the user, and the condition of the product.

МАГАЗИН МАЙСТОРА
БАШ ПРОФЕСИОНАЛНИ РЕШЕНИЯ



² Noise emissions in the environment measured as sound power (L_{WA}) as per EN ISO 3744 in conformity with EC directive 2000/14/EC. The difference between guaranteed and measured sound power is that the guaranteed sound power also includes dispersion in the measurement result and the variations between different machines of the same model according to Directive 2000/14/EC.

³ Sound pressure level L_p according to EN ISO 11201, EN 500-4. Uncertainty K_{PA} 3.0 dB (A).

⁴ Vibration value according to EN 500-4. Reported data for vibration level has a typical statistical dispersion (standard deviation) of 1.5 m/s^2 .

Product dimensions

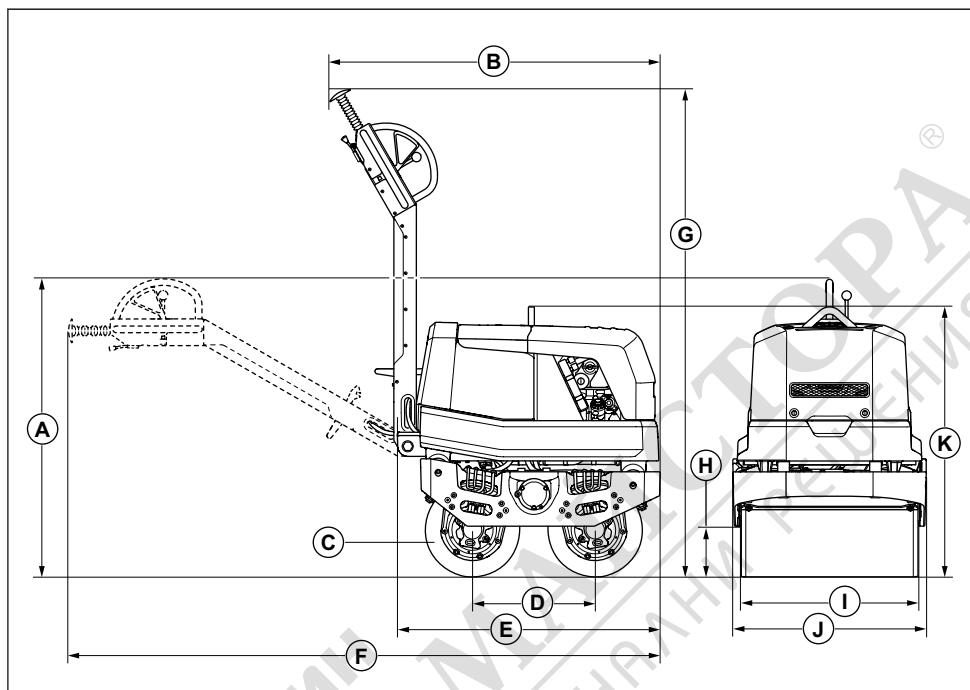

Pos.	Description	LP 6505	LP 7505
A	Handle height, operation position, mm/in.	1215/47.8	1260/49.6
B	Length with handle folded, handle included, mm/in.	1395/54.9	1395/54.9
C	Drum diameter, mm/in.	400/15.7	400/15.7
D	Distance between front and rear drum axles, mm/in.	520/20.5	520/20.5
E	Length with handle folded, handle not included, mm/in.	1110/43.7	1110/43.7
F	Length including handle, mm/in.	2500/98.4	2500/98.4
G	Handle height, transport position, mm/in.	2010/79.1	2055/81.0
H	Drum radius, mm/in.	215/8.7	215/8.7
I	Drum width, mm/in.	650/25.6	750/29.5
J	Width, mm/in.	720/28.3	820/32.3
K	Height without handle, mm/in.	1100/43.3	1100/43.3

EC Declaration of Conformity

EC Declaration of Conformity

We, **Husqvarna AB**, SE-561 82 Huskvarna, Sweden, tel: +46-36-146500, declare on our sole responsibility that the product:

Description	Drum Roller Compaction Machine
Brand	Husqvarna
Type/Model	LP 6505, LP 7505
Identification	Serial numbers dating from 2019 and onwards

complies fully with the following EU directives and regulations:

Directive/Regulation	Description
2014/30/EU	"relating to electromagnetic compatibility"
2006/42/EC	"relating to machinery"
2000/14/EC	"relating to outdoor noise"

and that the following harmonized standards and/or technical specifications are applied;

EN 500-1+A1:2009

EN 500-4:2011

Notified body: 0038, Lloyd's Register Verification Limited, 71 Fenchurch Street, London, EC3M 4BS, UK, has certified conformity with the Council's Directive 2000/14/EC, Annex VIII, Full Quality Assurance.

For information relating to noise emissions, refer to the chapter *Technical data on page 21*.

Partille, 2020-02-28



Martin Huber

R&D Director, Concrete Surfaces & Floors

Husqvarna AB, Construction Division

Responsible for technical documentation

Husqvarna®

www.husqvarnacp.com



Original instructions

1140346-26



2020-04-03