



PERFORMANCE RANGE

- Flow rate up to **90 l/min** (5.4 m³/h)
- Head up to **100 m**

APPLICATION LIMITS

- Manometric suction lift up to **8 m**
- Liquid temperature between **-10 °C** and **+60 °C**
- Ambient temperature up to **+40 °C** (**+50 °C** for PK 60)
- Max. working pressure:
 - **6 bar** for PK 60, PK 60-MD, PK 65,
 - **7 bar** for PK 70, PK 80
 - **10 bar** for PK 90, PK 100, PK 200, PK 300
- Continuous service **S1**

CONSTRUCTION AND SAFETY STANDARDS

EN 60335-1
IEC 60335-1
CEI 61-150

EN 60034-1
IEC 60034-1
CEI 2-3



CERTIFICATIONS

Company with management system certified DNV
ISO 9001: QUALITY



INSTALLATION AND USE

Suitable for use with clean water that does not contain abrasive particles and with liquids that are not chemically aggressive towards the materials from which the pump is made.

Because of their reliability and the fact that they are easy to use and are economical, they are ideal for domestic use and in particular for distributing water in combination with small pressure tanks and for the irrigation of gardens and orchards.

Installation needs to be undertaken in well ventilated closed areas or anyway protected from bad weather.

PATENTS - TRADE MARKS - MODELS

- Motor bracket: patent n. IT1243605
- Shaft: patent n. 0000275945 (PK60, PK65)
- Pump body: patent n. 0000275946 (PK60, PK65)
- Registered EU Design n. 004673192
- **PKm 60**[®] Registered Trade Mark n. 009875394

OPTIONS AVAILABLE ON REQUEST

- Special mechanical seal
- Other voltages or 60 Hz frequency
- IP X5 class protection for PK 70-80-90-100-200-300

CHARACTERISTIC CURVES AND PERFORMANCE DATA

50 Hz n= 2900 min⁻¹ HS= 0 m

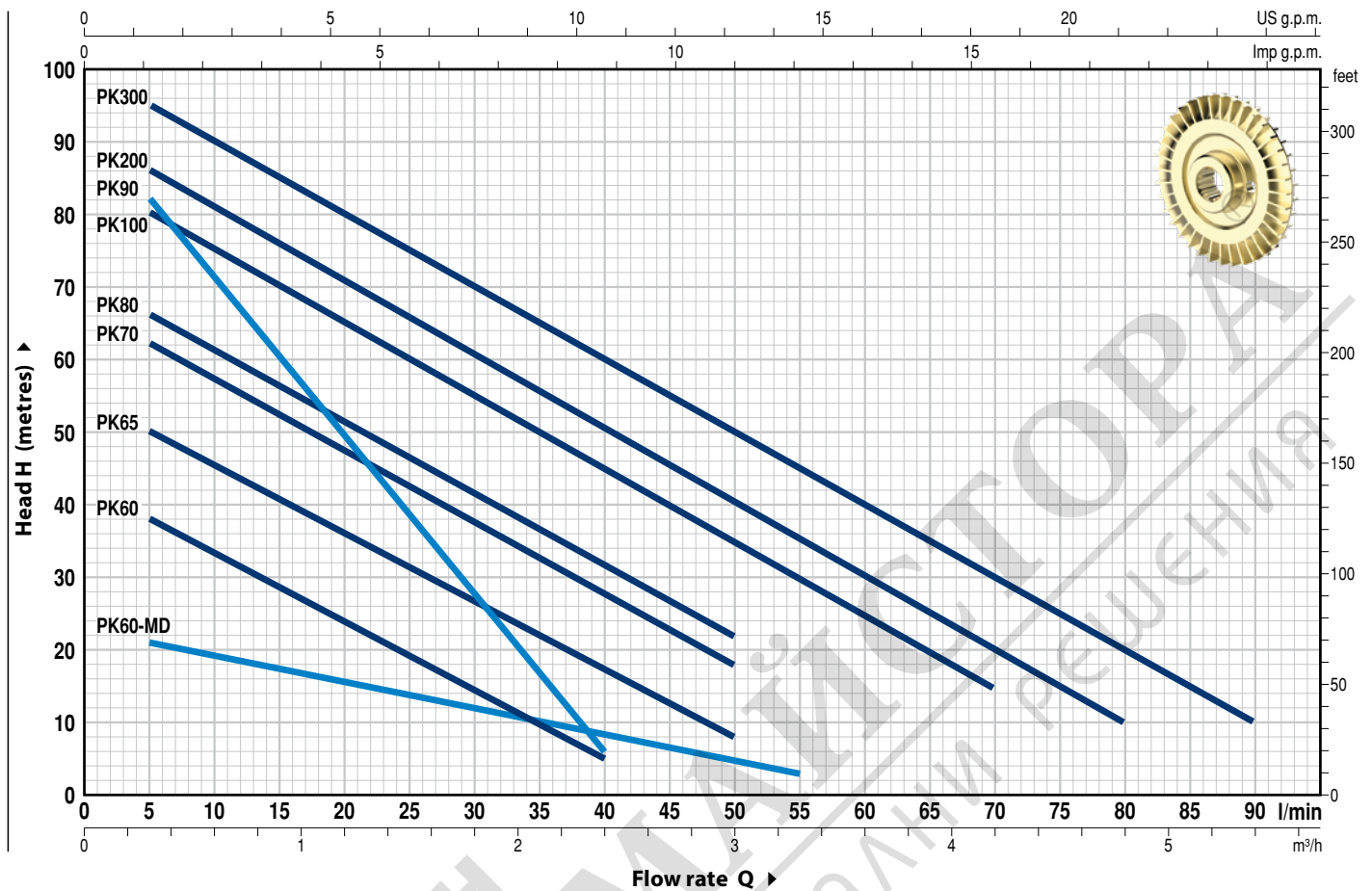

MODEL		POWER (P ₂)		Q	Flow rate															
Single-phase	Three-phase	kW	HP		m ³ /h	0	0.3	0.6	0.9	1.2	1.5	1.8	2.1	2.4	3.0	3.3	4.2	4.8	5.4	
				l/min	0	5	10	15	20	25	30	35	40	50	55	70	80	90		
PKm 60	PK 60	0.37	0.50	H metres	40	38	33.5	29	24	19.5	15	10	5							
PKm 60-MD	PK 60-MD	0.37	0.50		IE2	22	21	19	17.5	15.5	13.8	12	10	8.5	5	3				
PKm 65	PK 65	0.55	0.75		55	50	45.5	40.5	36	31	27	22	17	8						
PKm 70	PK 70	0.60	0.85		65	62	57	52	47	42	37	32	27	18						
PKm 80	PK 80	0.75	1		70	66	61	56	51	46	41	36.5	31	22						
PKm 90	PK 90	0.75	1		90	82	71	60	49	38	27	17	5							
PKm 100	PK 100	1.1	1.5		IE3	85	80	75	70	65	60	55	50	45	35	30	15			
PKm 200	PK 200	1.5	2		90	86	81	76	71	65.5	60	55	50	40	35	20	10			
PKm 300	PK 300	2.2	3		100	95	90	85	80	75	70	65	60	50	45	30	20	10		

Q = Flow rate H = Total manometric head HS = Suction height

Tolerance of characteristic curves in compliance with EN ISO 9906 Grade 3B.

▲ Three-phase motor efficiency class (IEC 60034-30-1)

POS. COMPONENT

CONSTRUCTION CHARACTERISTICS

1 PUMP BODY	Cast iron, with threaded ports in compliance with ISO 228/1 (PK 60, PK 60-MD with an Epoxy Electro Coating treatment)					
2 MOTOR BRACKET	Aluminium with brass insert (patented), reduces the risk of impeller seizure					
3 IMPELLER	Brass with peripheral radial vanes					
4 MOTOR SHAFT	Stainless steel AISI 431 (EN 10088-3 - 1.4104 for PK 60, PK 60-MD, PK 65)					
5 MECHANICAL SEAL	Pump	Seal	Shaft	Materials		
	<i>Model</i>	<i>Model</i>	<i>Diameter</i>	<i>Stationary ring</i>	<i>Rotational ring</i>	<i>Elastomer</i>
	PK 60-65-70-80 PK 60-MD	AR-12	Ø 12 mm	Ceramic	Graphite	NBR
	PK 90 PK 100-200-300	ST1-12 FN-14	Ø 12 mm Ø 14 mm	Silicon carbide Graphite	Graphite Ceramic	NBR NBR
6 BEARINGS	Pump	Model				
	PK 60-65 PK 60-MD	6201 ZZ / 6201 ZZ				
	PK 70-80-90	6203 ZZ / 6203 ZZ				
	PK 100-200-300	6204 ZZ / 6204 ZZ				
7 CAPACITOR	Pump	Capacitance				
	<i>Single-phase</i>	<i>(230 V or 240 V)</i>		<i>(110 V)</i>		
	PKm 60	10 µF - 450 VL		25 µF - 250 VL		
	PKm 60-MD	14 µF - 450 VL		25 µF - 250 VL		
	PKm 65	14 µF - 450 VL		25 µF - 250 VL		
	PKm 70	16 µF - 450 VL		60 µF - 300 VL		
	PKm 80	20 µF - 450 VL		60 µF - 300 VL		
	PKm 90	20 µF - 450 VL		60 µF - 300 VL		
	PKm 100	31.5 µF - 450 VL		60 µF - 250 VL		
	PKm 200	45 µF - 450 VL		80 µF - 250 VL		
	PKm 300	50 µF - 450 VL		-		
8 ELECTRIC MOTOR	PKm: single-phase 230 V - 50 Hz with thermal overload protector incorporated into the winding.					
	PK: three-phase 230/400 V - 50 Hz.					
<p>➔ The three-phase pumps are fitted with high performance motors up to P₂=0.55 kW in class IE2 and from P₂=0.60 kW in class IE3 (IEC 60034-30-1)</p> <ul style="list-style-type: none"> - Insulation: class F - Protection: IP X4 						

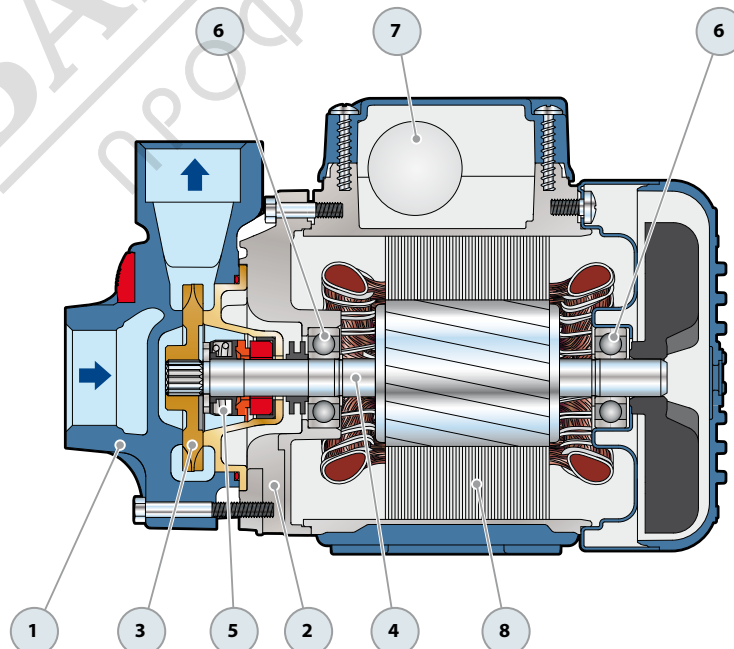

DIMENSIONS AND WEIGHT

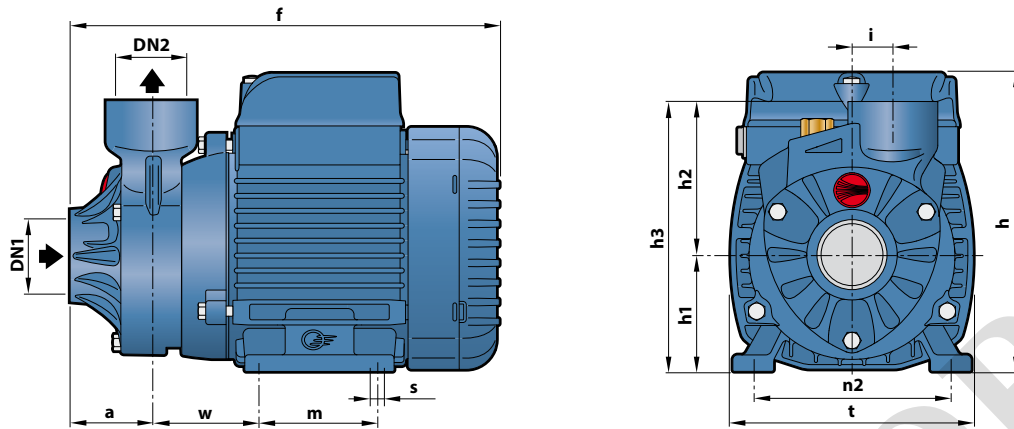

MODEL		PORTS		DIMENSIONS mm												kg	
Single-phase	Three-phase	DN1	DN2	a	f	h	h1	h2	h3	i	m	t	n2	w	s	1~	3~
PKm 60°	PK 60°	1"	1"	38	208	145	56	75	131	20	55	118	94-100	53	7	5.2	5.2
PKm 60°-MD	PK 60°-MD				237	153	63									80	120
PKm 65	PK 65			55	285	179 *	71	85	156		90	140	112	62		10.0	10.0
PKm 70	PK 70			46	278		84	155	19		10.2	10.1					
PKm 80	PK 80	¾"	¾"	62	356	212	80	88	168	19	100	152	125	95	9	15.0	14.9
PKm 90	PK 90	1"	1"	62	376	376	376	376	376	376	376	376	376	376	376	15.9	15.9
PKm 100	PK 100															15.0	14.9
PKm 200	PK 200															15.9	15.9
PKm 300	PK 300	—	—	—	—	—	—	—	—	—	—	—	—	—	—	—	18.6

(*) h=199 mm for single-phase versions at 110 V

ABSORPTION

MODEL	VOLTAGE		
Single-phase	230 V	240 V	110 V
PKm 60°	2.5 A	2.4 A	5.5 A
PKm 60°-MD	2.0 A	1.9 A	4.0 A
PKm 65	3.7 A	3.4 A	7.4 A
PKm 70	5.2 A	4.8 A	10.4 A
PKm 80	5.2 A	4.8 A	10.4 A
PKm 90	5.6 A	5.1 A	11.5 A
PKm 100	9.0 A	8.2 A	18.0 A
PKm 200	11.5 A	11.0 A	23.0 A
PKm 300	—	—	—

MODEL	VOLTAGE				
Three-phase	230 V	400 V	690 V	240 V	415 V
PK 60°	2.0 A	1.15 A	0.7 A	1.9 A	1.1 A
PK 60°-MD	1.7 A	1.0 A	0.6 A	1.7 A	1.0 A
PK 65	3.0 A	1.7 A	1.0 A	2.8 A	1.6 A
PK 70	3.8 A	2.2 A	1.3 A	3.3 A	1.9 A
PK 80	3.8 A	2.2 A	1.3 A	3.3 A	1.9 A
PK 90	4.0 A	2.3 A	1.3 A	3.8 A	2.2 A
PK 100	6.2 A	3.6 A	2.1 A	5.9 A	3.4 A
PK 200	8.3 A	4.8 A	2.8 A	8.0 A	4.6 A
PK 300	9.0 A	5.2 A	3.0 A	8.7 A	5.0 A

PALLETIZATION

MODEL		GROUPAGE	CONTAINER
Single-phase	Three-phase	n. pumps	n. pumps
PKm 60°	PK 60°	240	330
PKm 60°-MD	PK 60°-MD	240	330
PKm 65	PK 65	189	243
PKm 70	PK 70	102	170
PKm 80	PK 80	102	170
PKm 90	PK 90	102	170
PKm 100	PK 100	72	96
PKm 200	PK 200	72	96
PKm 300	PK 300	72	96