

# HF

## Centrifugal pumps

Medium flow

 Clean water

 Agricultural use

 Industrial use

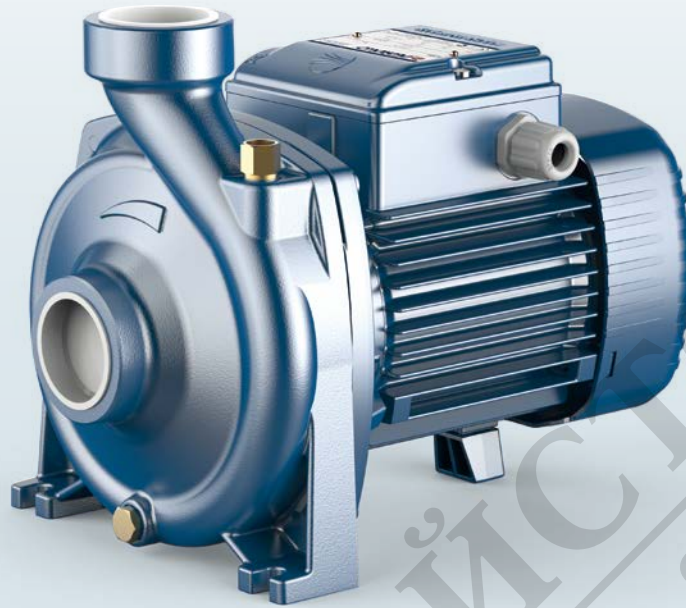

### PERFORMANCE RANGE

- Flow rate up to **600 l/min** (36 m<sup>3</sup>/h)
- Head up to **39 m**

### APPLICATION LIMITS

- Manometric suction lift up to **7 m**
- Liquid temperature between **-10 °C** and **+90 °C**
- Ambient temperature up to **+40 °C**
- Max. working pressure:
  - **6 bar** for HF 5-50-51
  - **10 bar** for HF 5M-70
- Continuous service **S1**

### CONSTRUCTION AND SAFETY STANDARDS

EN 60335-1  
IEC 60335-1  
CEI 61-150

EN 60034-1  
IEC 60034-1  
CEI 2-3



EU REGULATION N. 547/2012

### CERTIFICATIONS

Company with management system certified DNV  
ISO 9001: QUALITY



### INSTALLATION AND USE

Suitable for use in civil and agricultural applications. The high efficiency and continuous duty capabilities makes these pumps ideal for use in applications such as flood and spray irrigation, drawing water from lakes, rivers and wells, or for any number of different industrial applications where the characteristics of high flow rates and mid to low head are required. Installation needs to be undertaken in well ventilated closed areas or anyway protected from bad weather.

### OPTIONS AVAILABLE ON REQUEST

- Special mechanical seal
- Other voltages or 60 Hz frequency
- IP X5 class protection for HF 5M-70

## CHARACTERISTIC CURVES AND PERFORMANCE DATA

50 Hz n = 2900 min<sup>-1</sup> HS = 0 m

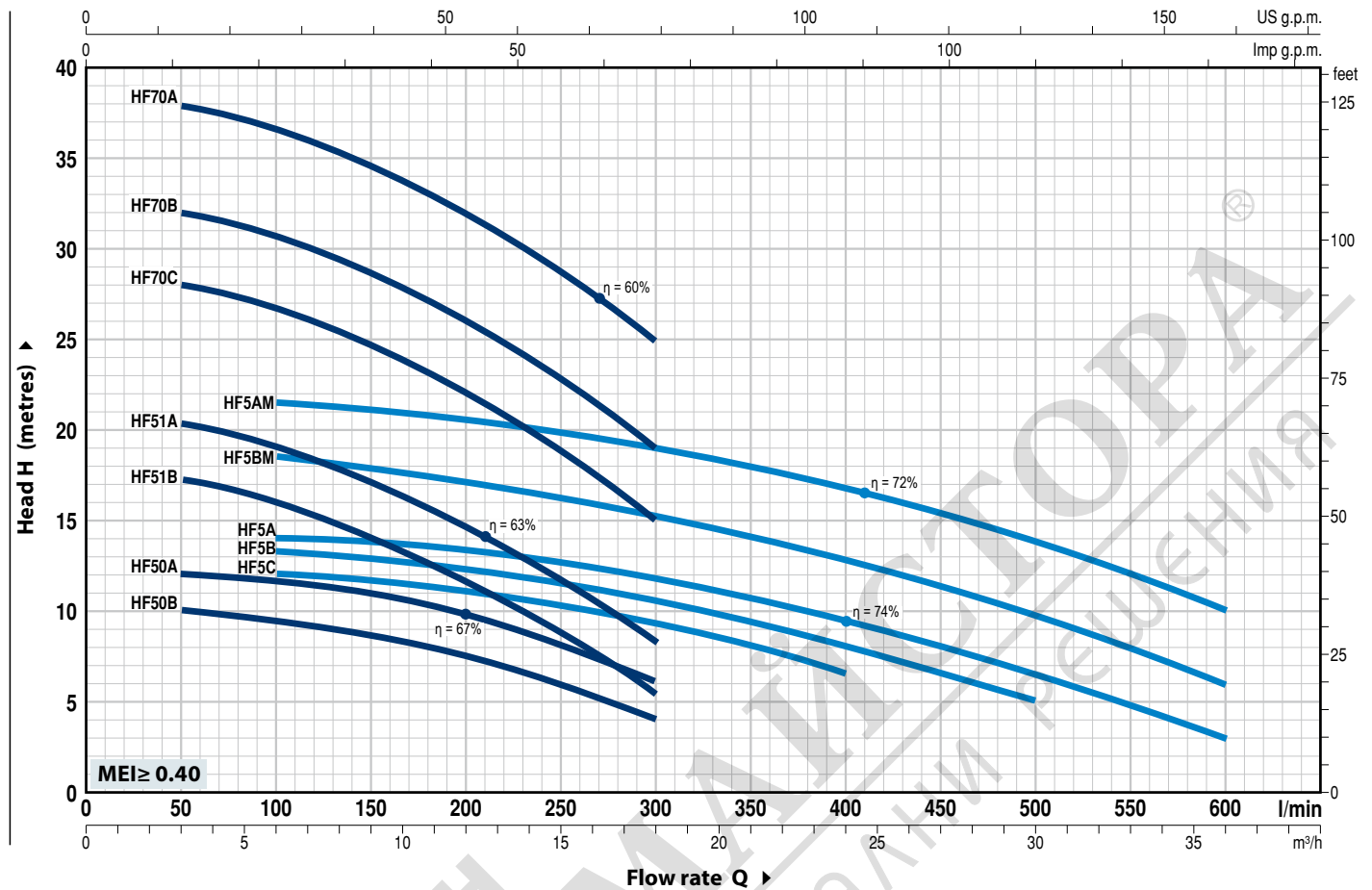

MODEL		POWER (P <sub>2</sub> )		Q	H metres												
Single-phase	Three-phase	kW	HP ▲		m <sup>3</sup> /h	0	3	6	9	12	15	18	21	24	30	36	
				l/min	0	50	100	150	200	250	300	350	400	500	600		
HFm 50B	HF 50B	0.37	0.50	H metres	10	10	9.5	8.5	7.5	6	4						
HFm 50A	HF 50A	0.55	0.75		12	12	11.5	11	9.6	8	6						
HFm 51B	HF 51B	0.55	0.75		18.2	17.2	16	14	11.5	9	5.4						
HFm 51A	HF 51A	0.75	1		21.2	20.2	19	17	14.5	11.6	8.4						
HFm 70C	HF 70C	1.1	1.5		29	28	26.5	24.5	22	18.5	15						
HFm 70B	HF 70B	1.5	2		33	32	30.5	28.5	26	22.5	19						
-	HF 70A	2.2	3		39	38	36.5	34.5	32	28.5	25						
HFm 5C	HF 5C	0.55	0.75		12.5	-	12	11.7	11	10.2	9.2	8	6.5				
HFm 5B	HF 5B	0.75	1		13.7	-	13.2	13	12.5	11.6	10.5	9.2	8	5			
HFm 5A	HF 5A	1.1	1.5		14.5	-	13.8	13.5	13.2	12.6	11.8	10.5	9.2	6.5	3		
HFm 5BM	HF 5BM	1.1	1.5	19	-	18.5	18	17	16	15.2	14	12.8	9.7	6			
HFm 5AM	HF 5AM	1.5	2	22	-	21.5	21	20.5	19.8	19	18	16.8	13.8	10			

Q = Flow rate H = Total manometric head HS = Suction height

Tolerance of characteristic curves in compliance with EN ISO 9906 Grade 3B.

▲ Three-phase motor efficiency class (IEC 60034-30-1)

## POS. COMPONENT CONSTRUCTION CHARACTERISTICS

1	<b>PUMP BODY</b>	Cast iron complete with threaded ports in compliance with ISO 228/1					
2	<b>BODY BACKPLATE</b>	Stainless steel AISI 304 (cast iron for HF 5M-70)					
3	<b>IMPELLER</b>	Brass					
4	<b>MOTOR SHAFT</b>	Stainless steel AISI 431					
5	<b>MECHANICAL SEAL</b>	<i>Pump</i>	<i>Seal</i>	<i>Shaft</i>	<i>Materials</i>		
		<i>Model</i>	<i>Model</i>	<i>Diameter</i>	<i>Stationary ring</i>	<i>Rotational ring</i>	<i>Elastomer</i>
		HF 50	AR-12	Ø 12 mm	Ceramic	Graphite	NBR
		HF 5-51	AR-14	Ø 14 mm	Ceramic	Graphite	NBR
HF 5M-70	FN-18	Ø 18 mm	Graphite	Ceramic	NBR		
6	<b>BEARINGS</b>	<i>Pump</i>	<i>Model</i>				
		HF 50	6201 ZZ / 6201 ZZ				
		HF 5-51	6203 ZZ / 6203 ZZ				
		HF 5M-70	6204 ZZ / 6204 ZZ				
7	<b>CAPACITOR</b>	<i>Pump</i>	<i>Capacitance</i>				
		<i>Single-phase</i>	<i>(230 V or 240 V)</i>	<i>(110 V)</i>			
		HFm 50B	10 µF - 450 VL	25 µF - 250 VL			
		HFm 50A	14 µF - 450 VL	25 µF - 250 VL			
		HFm 51B	20 µF - 450 VL	60 µF - 300 VL			
		HFm 51A	20 µF - 450 VL	60 µF - 300 VL			
		HFm 70C	25 µF - 450 VL	60 µF - 250 VL			
		HFm 70B	45 µF - 450 VL	80 µF - 250 VL			
		HFm 5C	16 µF - 450 VL	60 µF - 300 VL			
		HFm 5B	20 µF - 450 VL	60 µF - 300 VL			
		HFm 5A	25 µF - 450 VL	60 µF - 300 VL			
		HFm 5BM	25 µF - 450 VL	60 µF - 250 VL			
HFm 5AM	45 µF - 450 VL	80 µF - 250 VL					
8	<b>ELECTRIC MOTOR</b>	HFm: single-phase 230 V - 50 Hz with thermal overload protector incorporated into the winding.					
		HF: three-phase 230/400 V - 50 Hz.					
		<p>→ The three-phase pumps are fitted with high performance motors up to P<sub>2</sub>=0.55 kW in class IE2 and from P<sub>2</sub>=0.75 kW in class IE3 (IEC 60034-30-1)</p> <ul style="list-style-type: none"> <li>- Insulation: class F</li> <li>- Protection: IP X4</li> </ul>					

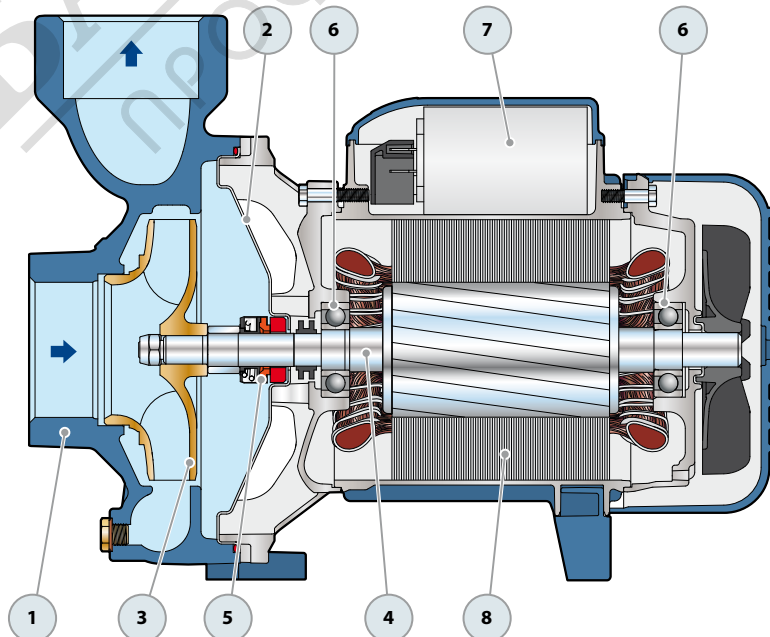

## DIMENSIONS AND WEIGHT

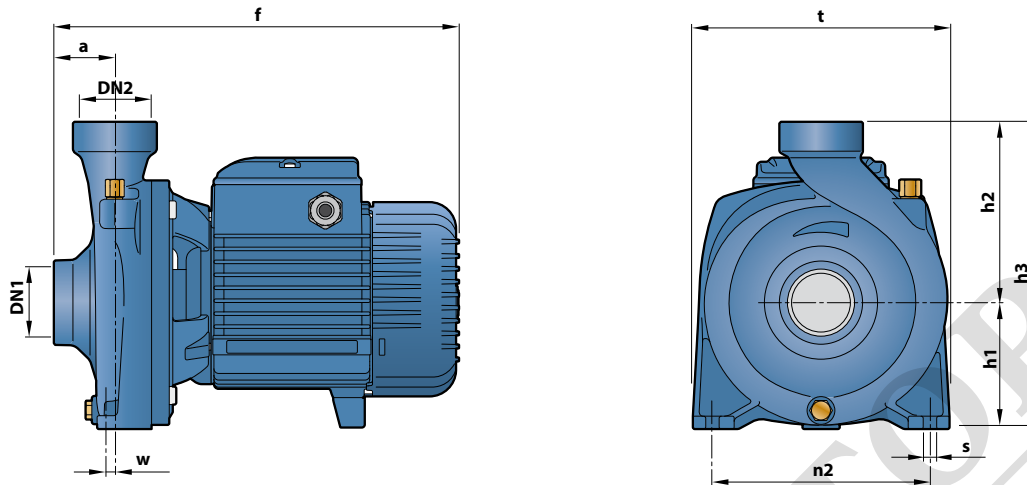

MODEL		PORTS		DIMENSIONS mm									kg			
Single-phase	Three-phase	DN1	DN2	a	f	h1	h2	h3	t	n2	w	s	1~	3~		
HFm 50B	HF 50B	1½"	1½"	42	270	82	118	200	166	135	-8	10	8.0	8.1		
HFm 50A	HF 50A					92	133	225	190				160	2	12.9	12.7
HFm 51B	HF 51B			48.5	373	114	155	269	216	171	12		12	18.8	20.1	
HFm 51A	HF 51A					97	141	238	192	-68	10		14.3	14.3		
HFm 70C	HF 70C					59	393	110	150	260	208		12.5	11	19.2	20.3
HFm 70B	HF 70B							12.5	11	21.6	21.6					
-	HF 70A	12.5	11	-	24.2											
HFm 5C	HF 5C	2"	2"	43	316	97	141	238	192	160	-68	10	14.3	14.2		
HFm 5B	HF 5B					97	141	238	192				-68	10	14.3	14.3
HFm 5A	HF 5A			59	386	110	150	260	208	12.5	11	14.6	14.7			
HFm 5BM	HF 5BM					12.5	11	19.2	20.3							
HFm 5AM	HF 5AM					12.5	11	21.6	21.6							

## ABSORPTION

MODEL	VOLTAGE		
Single-phase	230 V	240 V	110 V
HFm 50B	2.8 A	2.6 A	5.6 A
HFm 50A	3.8 A	3.6 A	7.6 A
HFm 51B	4.7 A	4.5 A	9.4 A
HFm 51A	5.6 A	5.3 A	11.2 A
HFm 70C	8.0 A	7.6 A	16.0 A
HFm 70B	10.0 A	9.0 A	20.0 A
HFm 5C	4.2 A	3.8 A	8.4 A
HFm 5B	4.9 A	4.5 A	9.8 A
HFm 5A	6.2 A	5.7 A	12.4 A
HFm 5BM	7.7 A	7.1 A	15.4 A
HFm 5AM	10.1 A	9.7 A	20.2 A

MODEL	VOLTAGE					
Three-phase	230 V	400 V	690 V	240 V	415 V	720 V
HF 50B	2.1 A	1.2 A	0.7 A	2.1 A	1.2 A	0.7 A
HF 50A	3.0 A	1.7 A	1.0 A	2.8 A	1.6 A	0.9 A
HF 51B	3.6 A	2.1 A	1.2 A	3.5 A	2.0 A	1.2 A
HF 51A	4.4 A	2.5 A	1.2 A	4.0 A	2.3 A	1.4 A
HF 70C	6.1 A	3.3 A	2.0 A	5.5 A	3.2 A	1.9 A
HF 70B	7.4 A	4.3 A	2.5 A	7.1 A	4.1 A	2.4 A
HF 70A	9.5 A	5.5 A	3.2 A	9.1 A	5.3 A	3.0 A
HF 5C	3.5 A	2.0 A	1.2 A	3.3 A	1.9 A	1.1 A
HF 5B	3.6 A	2.1 A	1.2 A	3.5 A	2.0 A	1.2 A
HF 5A	5.0 A	2.9 A	1.7 A	3.6 A	2.1 A	1.6 A
HF 5BM	5.7 A	3.3 A	1.9 A	5.5 A	3.2 A	1.8 A
HF 5AM	7.1 A	4.1 A	2.4 A	6.5 A	3.7 A	2.3 A