



LYNX

ELEKTRO MASCHINEN

Auto Darkening Welding Mask

WHEm 913

User's manual

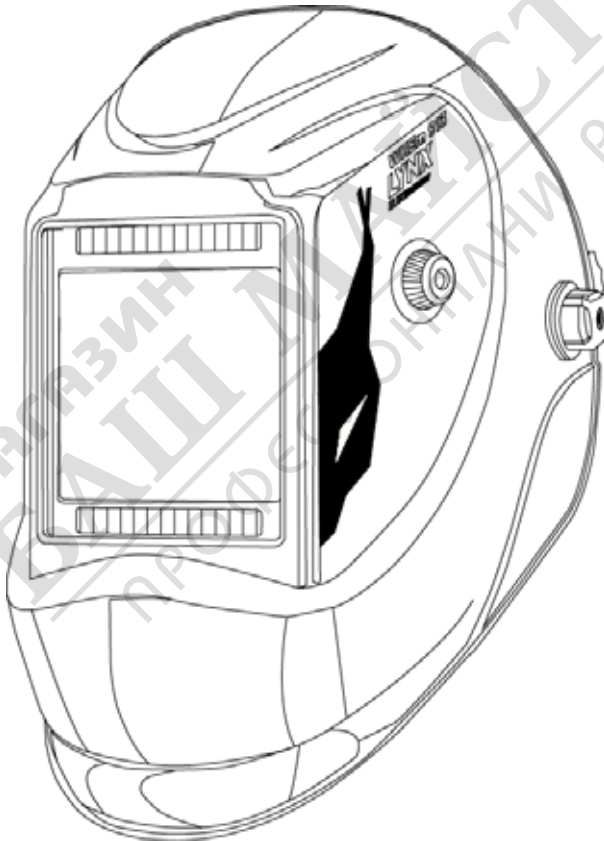

Pay attention to self-safety and read this manual carefully while installing and operating this product.

I、 Main characters:

- 1、 The safe structure design adopts a world famous style, conform to the ergonomic principle, and provides an ample internal space. which makes it easy to operate and comfortable to wear. The helmet shell materials with soft texture are resistant to high/low temperature, corrosion, flame-retardant and light-proof, with high strength, and durable. It may comprehensively protect your face, neck, and so on.
- 2、 Liquid crystal of high quality and optical coating, and protection for shielding ultraviolet and infrared rays(level of protection:13#) are adopted to protect welding operator from being injured by harmful rays such as ultraviolet rays, infrared rays, etc .
- 3、 The original design of automatic transform technology used in controlling circuit make it possible for goggles to be able to react quickly and change strong light to dark light. As a result, it can protect our eyes from being injured by sudden arc.
- 4、 Unique design anti-interference switch avoids not seeing welding object clearly due to complex surrounding nearby.
- 5、 Dark shade DIN9~DIN13,stepless control, set by hand according to actual situation.
- 6、 Dark to light : 0.1 s~ 1.0 s , stepless control.
- 7、 With grinding function

II、 Working principle

Different with traditional passive shading lens, made from various additives and pigment. ADF adopts LCD as lens ADF , using the probe on mirror surface to probe the appearance and disappearance of arc when welding , and using electricity to drive shading level of the LCD to achieve the goal of protecting us from harmful rays, can absolutely reflect ultraviolet rays and ultrared rays .In addition, hands are thoroughly set free. Welding is more exactly. Therefore, efficiency is improved.

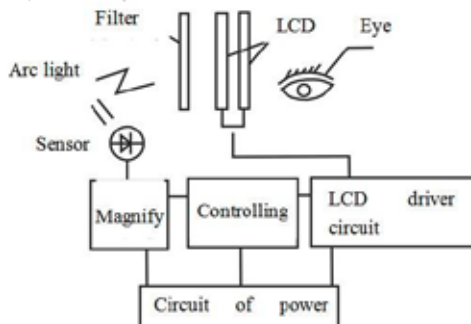

III、 Main technical parameter

Filter Model	WHEm 913
Filter Size	110mm×90mm×9mm
Active Viewing Area	92.5×42.5
Light Shade	DIN3.5
Dark Shade	DIN9~13
Way to shift Dark State	Outer control, stepless shift
Switching Time	3/10000S±20%
Sensitivity Adjustment	Stepless Control
Delay Time	0.1S~1.0S
Power supply	Lithium battery & Solar supply
Rated Capacity of Lithium Battery	600mAh
Replaceable Lithium Battery	YES
Operating Temperature	-5°C~+55°C
Sensors to Weld Arc	2
Grind	YES
Low battery	YES
Test	YES



IV、Structure of welding mask and installation of headband

1、Structure of welding mask

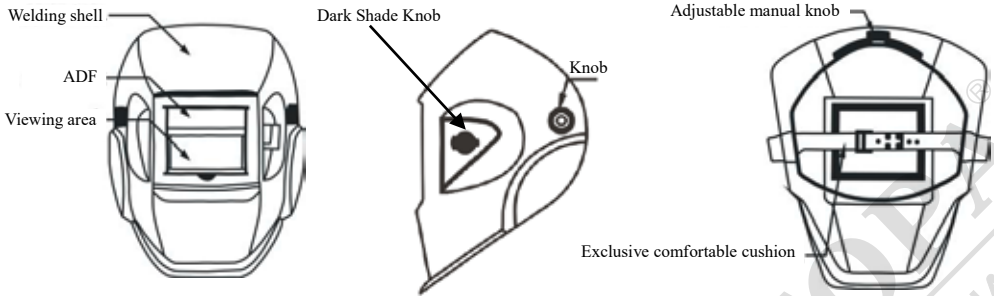

2、Description of Headband Installation:

- a、 Take out the headband, and disassemble it according to the exploded view below:

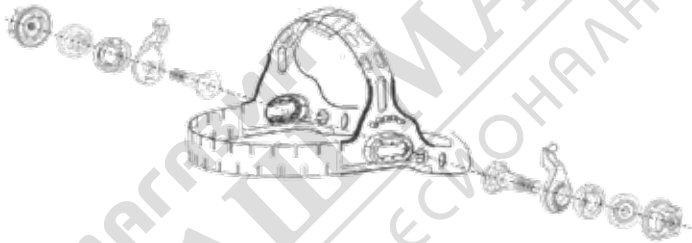

- b、 Take out the mask and install the headband according to the exploded view below:

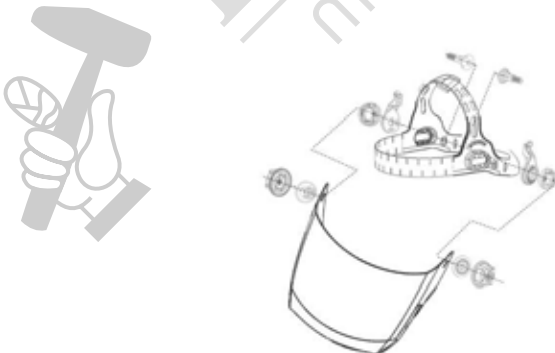

3、Description of Mask Adjustment::

a、 Turn the headband first to make the headband adjusting knob at the back of the head, press with hand and turn counterclockwise the headband diameter adjusting knob to broaden the headband size; otherwise, narrow it.

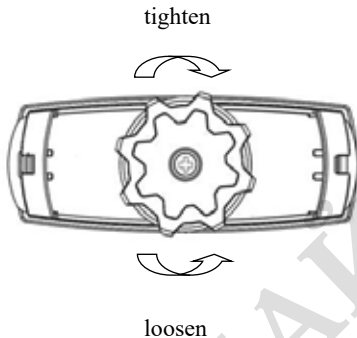

b、 Adjust the band depth location hole to adjust the lengthwise position of the headband from head top to eyes;

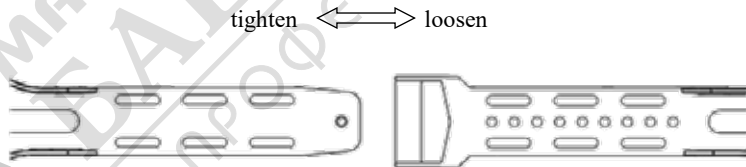

c、 Loosen lug nuts at both sides to make the mask move back and forth in the long mobile hole of the head loop so as to adjust the distance from the window view to eyes;

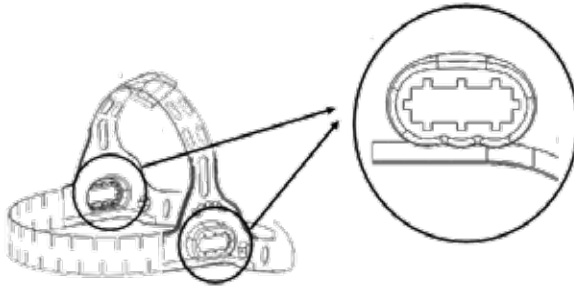

- d、 Fix locating piece on different locating columns to adjust the window view angle, slightly adjust the required angle of elevation, horizontal view angle, and top view angle;

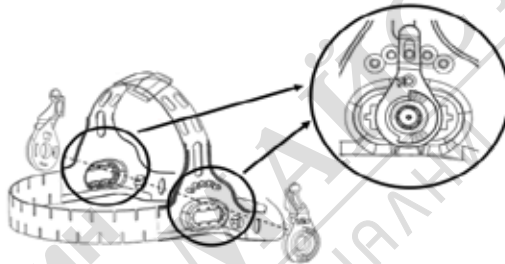

- e、 Loosen lug nuts at both sides to adjust the vertical angle of the mask , to turn up or down the mask; you may hear "chuck-chuck" during adjusting.
- f、 The buckle is equipped with two adjust position to lock the welding cap when it is lifted to the higher point, so as to make workers observe easier after welding.

Caution: The buckle is locked before use. When you use the welding helmet for the first time, please unlock it by rotating the headband, and there will be a "click" sound when the headband is unlocked and locked!

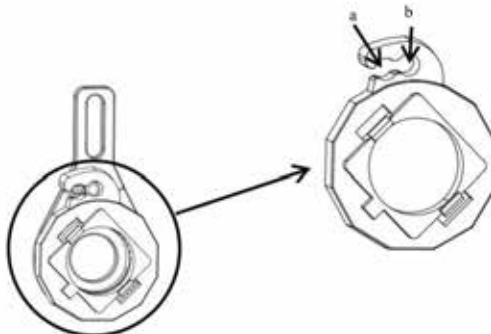

VI. Auto darkening filter's operation instruction

1. Dark shade:

The table below is the darkness color number comparison table; please select correct darkness color number based on the actual working conditions so as to reach the optimal protection and work efficiency:

Welding current (A)	0.5	1	2.5	5	10	15	20	30	40	60	80	100	125	150	175	200	225	250	275	300	350	400	450	500
Shielded metal arc (SMAW)									9	10			11				12					13		14
MIG (heavy)												10	11				12					13		14
MIG (light)												10	11			12		13				14		15
TIG, GTAW						9	10		11			12				13						14		
MAG (CO ₂)										10	11	12				13						14		15
SAW												10	11	12	13	14	15							
PAC												11		12								13		
PAW				8	9	10	11			12			13								14			15

2. Sensitivity adjustment:

Choose the appropriate sensitivity, not only realize the anti-interference capability, but also achieve better work.

- (1)、when welding current is small, you need to put the "sensitivity" knob to high place, so you can detect weak stable arc;
- (2)、when welding current is big, you need to put the "sensitivity" knob to low place, You can avoid the arc interference by others;
- (3)、During TIG welding, the sensitivity can be set to the middle or middle facing up position to prevent unstable dimming or flickering. In practical use, the sensitivity can be adjusted while welding to find a suitable position for use;



- (4)、sensitivity is stepless control, set by hand according to actual situation

3. Delay time:

Delay time is time from dark to light, Stepless control.

- (1)、When welding current is big and the light of molten pool is very strong, you need to put the "delay" knob to high place, so you can avoid the glasses to be wounded by the light of

molten pool.

- (2)、 If you want to do spot welding, you need to put the “delay” knob to low place , so you can improve the work efficiency.
- (3)、 Adjust “delay” knob to middle place is suitable for most of welding mode.
- (4)、 Please note that when both sensitivity and delay functions are set to their maximum, there may be a phenomenon of continuously turning black and not returning to the bright state. Simply adjust the sensitivity back a bit to restore normal operation;

4. Welding/Grinding function:

The welding/grinding function is switched through the knob on the helmet body. When it is switched to "Grind", it means it enters grinding mode under which the auto darkening filter will not turn black when detecting any arc light; therefore, please switch to the correct position based on service conditions before using;

5. “TEST” button



If you put the “TEST” button , the filter turn black , the filter can work.

6. Low battery alarm:



When the light of low battery is red, you need replace the new battery, Please replace the battery according to the view below:

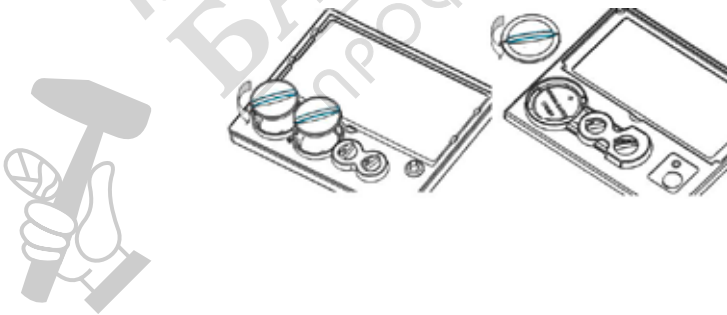

VII. Precautions for Use of Helmet

1. Before using the auto darkening welding helmet, please first tear off the films attached to the inside and outside PC screening glass of the window, adjusting the tightening knob between headband and helmet body, and then adjust the headband diameter and depth properly for wearing;
2. Test with standard incandescent lamps of 40W or above before using , the liquid crystal will turn black when you put lamps near it;
3. Do not put the helmet on any high-temperature weld joint after welding;
4. Do not take the helmet as safety helmet;
5. Replace unclear or damaged inside or outside screening glass timely to ensure the lines of sight;
6. In order to protect the product from damage, please do not clean it with clear water or cleaning solvent; please use soft tissues or cloth for cleaning;
7. In order to ensure proper working of the auto darkening filter, please keep the sensors of weld arc on it clean and out other objects;
8. When the ambient temperature is relatively low, the liquid crystal materials in the cartridge may become a little retardant while it has no influence on various protective properties.

VIII. ADF Filter

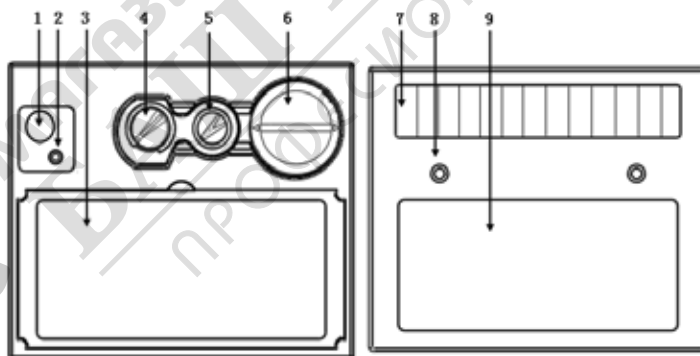

LY600

1. ADF Self-check button
2. Low volume alarm
3. LCD protect plate
4. Sensitivity control knob
5. Delay time control knob

6. Lithium Battery
7. Solar cell
8. Sensor
9. UV, IR filter

IX. After Service

Dear users:

Please go through relevant insurance formalities timely according to the warranty card after purchasing the product; if you need any help during use, please contact local agents. **We earnestly promise customers: For all products sold by our company (excluding quick-wear parts), we provide one year warranty and life-long maintenance service.** Your valuable comments and suggestions are welcome.

Note: Any man-made damage or any damage arising from improper use or failure to follow the user manual is outside the scope of free warranty. You will be charged for the costs of any repair by the price of parts.

Please record the following data for contacting

Warranty card

Type of Product		Serial number	
Place of purchase		Date of purchase	
Telephone of Agent		Invoice no	

