

SUPREME

MARBLE BRIDGE SAWS

*Designed
and made
in Italy*

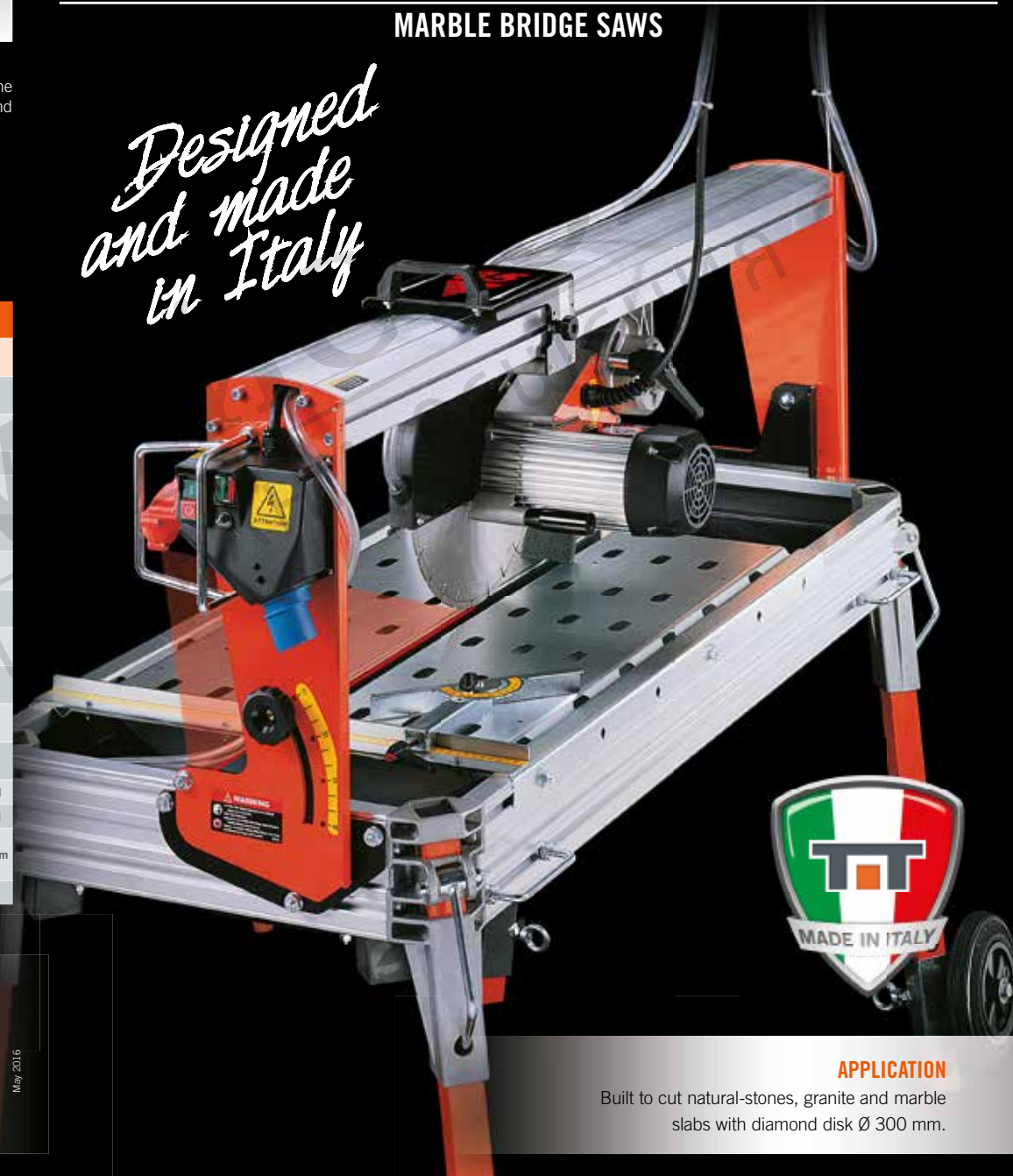

CONTROL BOARD

The control board includes:

- Switch with release coil.
- Overheat protection with manual reset in the event of the disk jamming.
- Red light for net connection.
- Green light for machine on function.
- Laser instrument for the maximum cutting precision.

CUTTING DEPTH

A graduated scale measures the adjustment of the cutting depth by locking the engine group.

STORAGE

Built to reduce at the maximum the encumbrance during the carriage and above all the storage space.

	SUPREME 55		SUPREME 85		SUPREME 100		SUPREME 120		SUPREME 150		SUPREME 200	
Article	Art. 8055	Art. 80551	Art. 8085	Art. 80851	Art. 8100	Art. 81001	Art. 8120	Art. 81201	Art. 8150	Art. 81501	Art. 8200	Art. 82001
CUTTING DISK Ø300 (int ø25,4mm.)	Optional											
ENGINE	Single phase / 230V/50Hz / 3Hp/2,2Kw											
ROTATION SPEED	2800 rpm											
AMPEROMETRICAL PROTECTION	13 A											
MAX CUTTING LENGTH	550 mm		850 mm		1000 mm		1200 mm		1500 mm		2000 mm	
MAX SIZE TILE FOR DIAGONAL CUTS	385 x 385 mm		600 x 600 mm		705 x 705 mm		845 x 845 mm		1060 x 1060 mm		1410 x 1410 mm	
MAX CUTTING DEPTH AT 90°	85 mm											
MAX CUTTING DEPTH WITH 2 RUNS	135 mm											
MAX CUTTING DEPTH AT 45°	60 mm											
WORKING TABLE SIZE	555 x 625 mm		855 x 625 mm		1185 x 625 mm		1485 x 625 mm		1485 x 625 mm		2055 x 625 mm	
WATER RECYCLING PUMP TYPE	S3 standard											
KIT WHEELS	Optional	Standard	Optional	Standard	Optional	Standard	Optional	Standard	Optional	Standard	Optional	Standard
LASER INSTRUMENT	Optional	Standard	Optional	Standard	Optional	Standard	Optional	Standard	Optional	Standard	Optional	Standard
DIMENSION MACHINE IN STOCK	720x1300x h. 1000 mm		720x1600x h. 1000 mm		720x1750x h. 1000 mm		720x1950x h. 1010 mm		720x2250x h. 1000 mm		720x2750x h. 1000 mm	
NET WEIGHT	75 Kg	79 Kg	80 Kg	83 Kg	83 Kg	87 Kg	86 Kg	90 Kg	92 Kg	96 Kg	99 Kg	103 Kg

BATTIPAV™

MACCHINE PER EDILIZIA | MACHINES FOR BUILDING

Z. i. 2 - Via Cavatorta, 6/1 | 48033 Cotignola (Ra) | ITALY
Tel. +39 0545 40004 | Fax +39 0545 41724
www.battipav.com | sales@battipav.com

AUTHORIZED DEALER:



May 2016

APPLICATION

Built to cut natural-stones, granite and marble slabs with diamond disk Ø 300 mm.



The carriage engine group slides with 8 ball-bearings on interchangeable stainless steel track.



Position for 45° angle cuts.



The **CUTTING PROGRESS SYSTEM** with **HANDWHEEL** adjusts the movement of the cutting head forward or behind.



SIDE TILE SUPPORT
Made to have the top straight and angled cuts angle-shot cut.
Optional for the mode

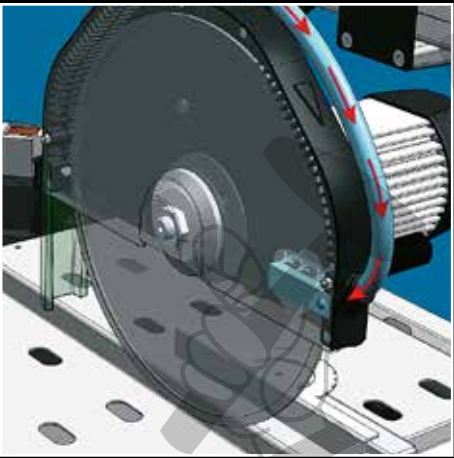

Spray system
DISK'S LUBRICATION



ORIGINAL RECYCLED