

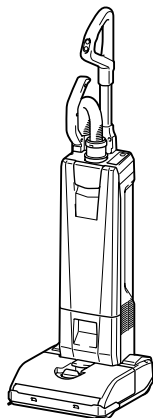

EN	Cordless Upright Cleaner	INSTRUCTION MANUAL	8
FR	Aspiro-brosseur sans fil	MANUEL D'INSTRUCTIONS	18
DE	Akku-Standstaubsauger	BETRIEBSANLEITUNG	30
IT	Aspirapolvere verticale a batteria	ISTRUZIONI PER L'USO	43
NL	Staande accustofzuiger	GEBRUIKSAANWIJZING	55
ES	Limpiador Vertical Inalámbrico	MANUAL DE INSTRUCCIONES	68
PT	Aspirador de Pó Vertical a Bateria	MANUAL DE INSTRUÇÕES	80
DA	Akku oprejst støvsuger	BRUGSANVISNING	91
EL	Φορητή όρθια σκούπα αναρρόφησης	ΕΓΧΕΙΡΙΔΙΟ ΟΔΗΓΙΩΝ	101
TR	Akülü Dikey Süpürge	KULLANMA KILAVUZU	114

DVC560



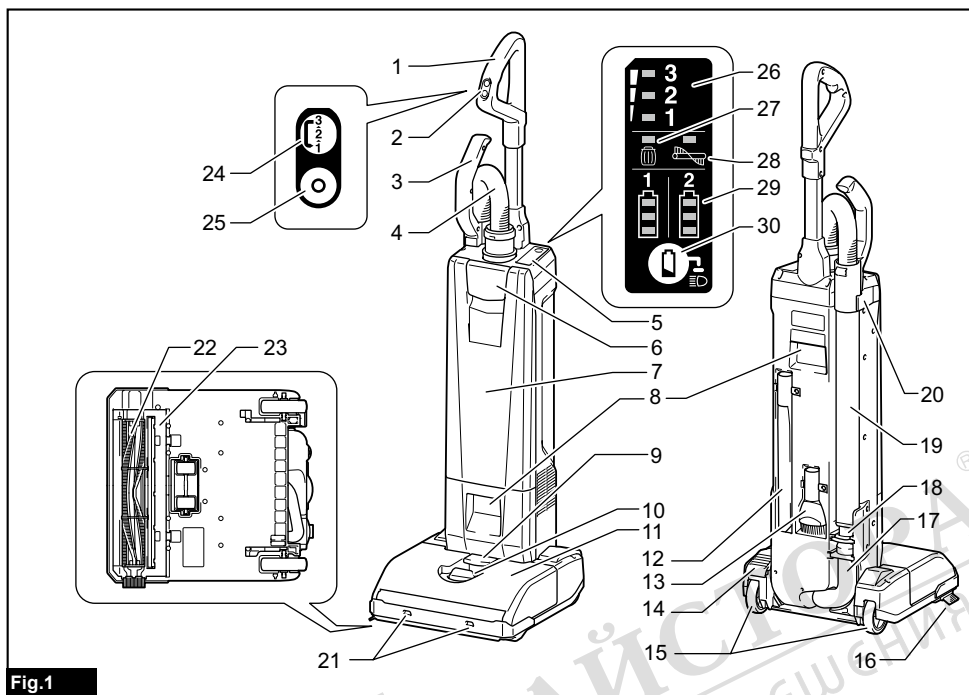

Fig.1

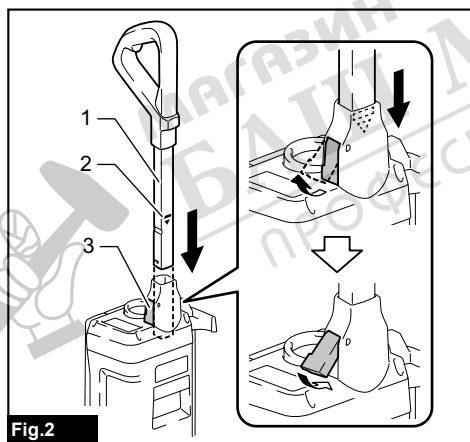

Fig.2

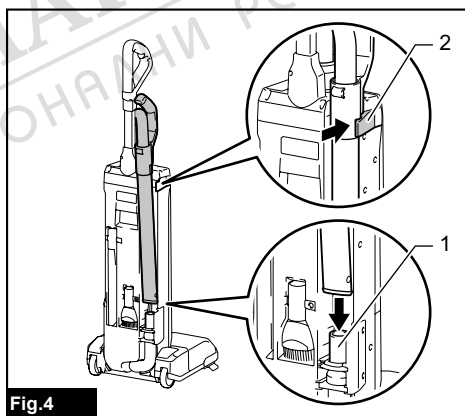

Fig.4

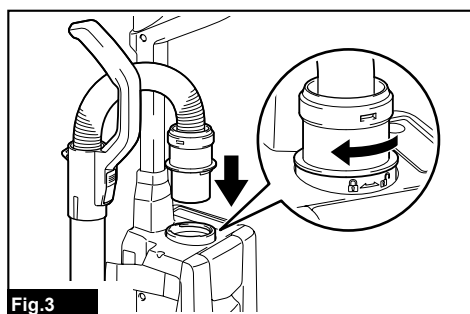

Fig.3

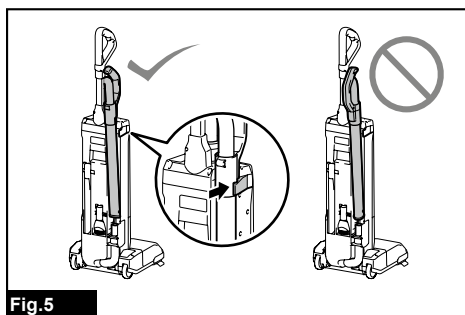

Fig.5

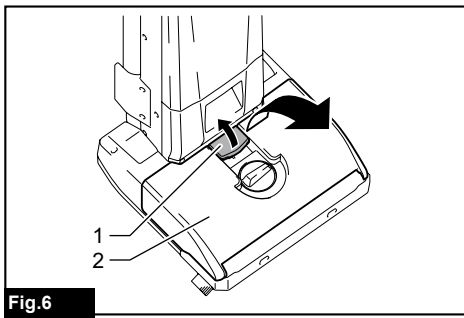

Fig.6

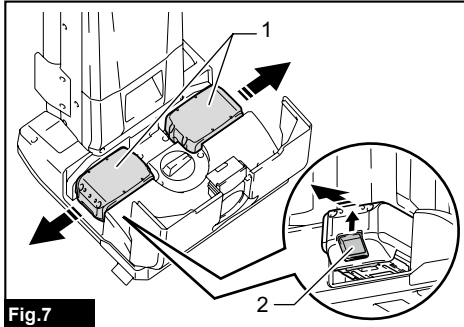

Fig.7

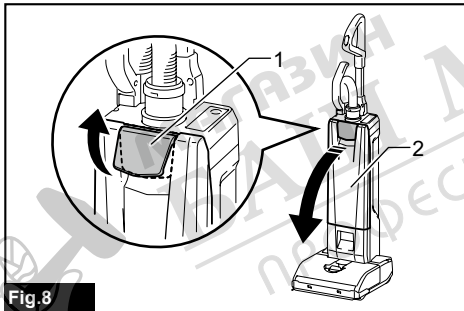

Fig.8

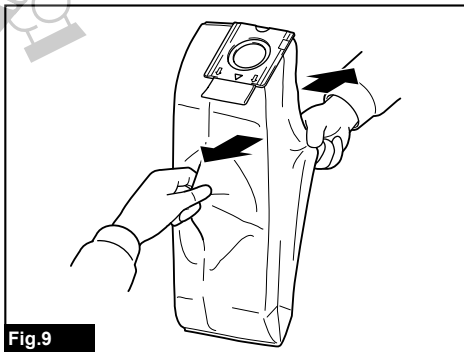

Fig.9

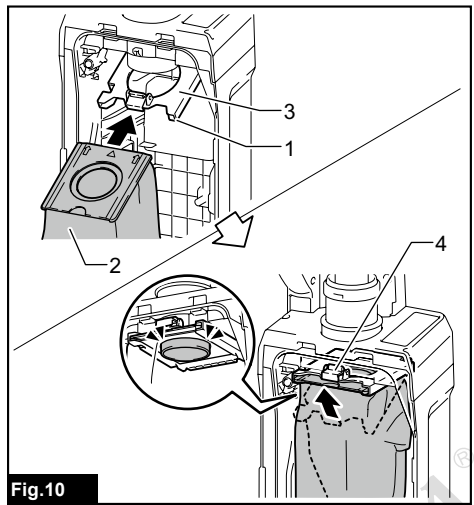

Fig.10

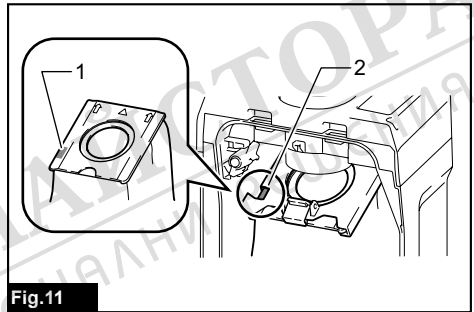

Fig.11

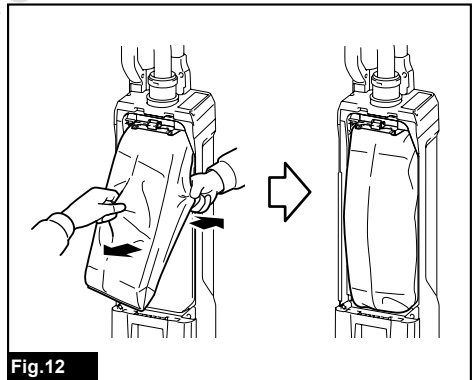

Fig.12

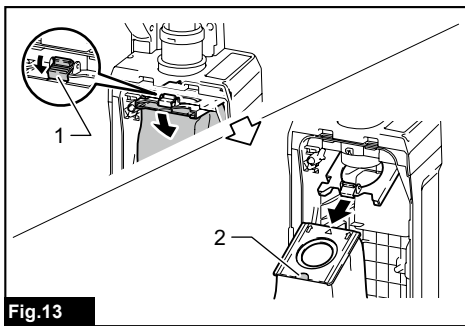

Fig.13

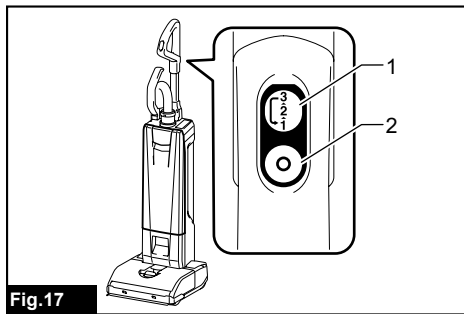

Fig.17

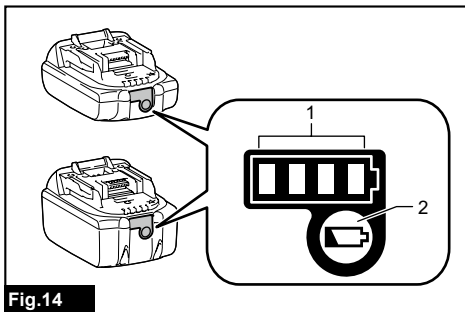

Fig.14

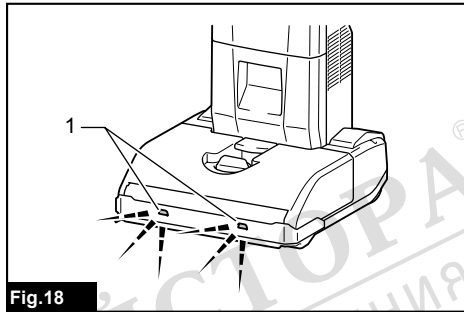

Fig.18

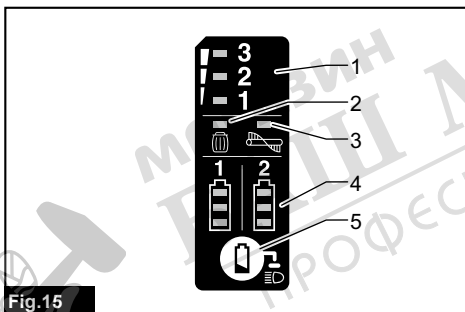

Fig.15

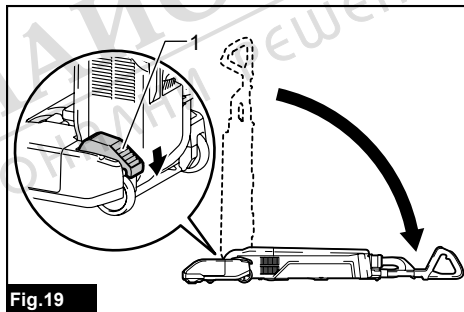

Fig.19

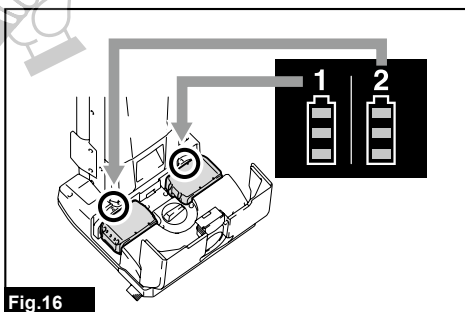

Fig.16

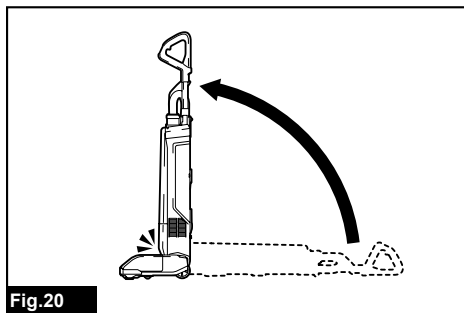

Fig.20

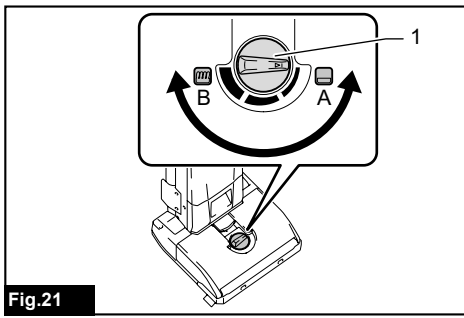

Fig.21

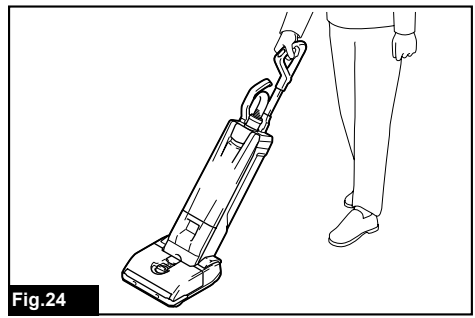

Fig.24

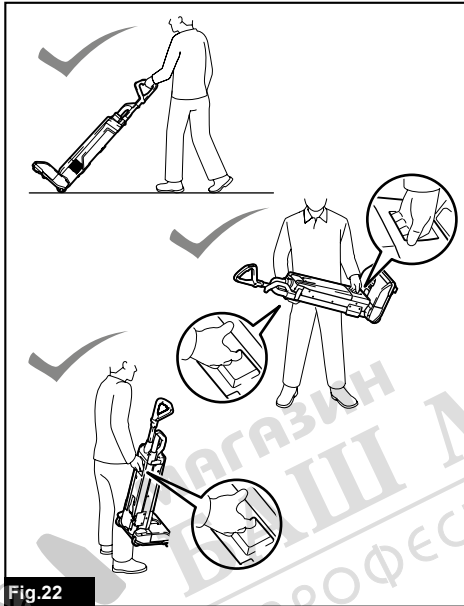

Fig.22

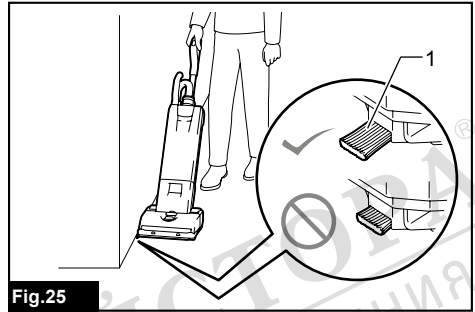

Fig.25

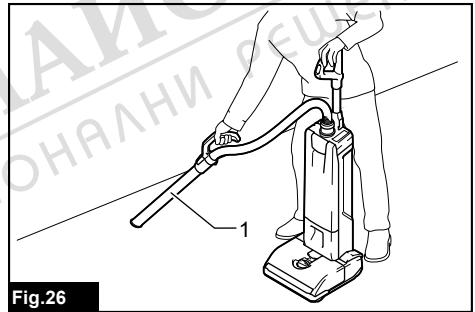

Fig.26

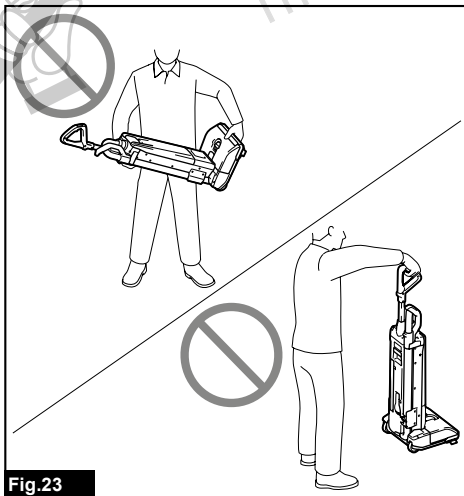

Fig.23

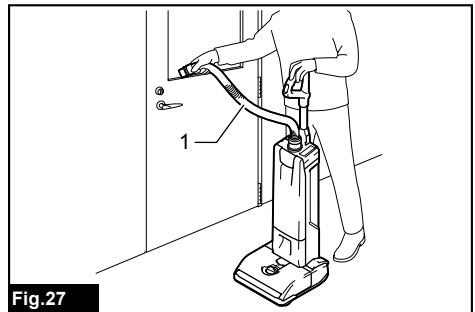
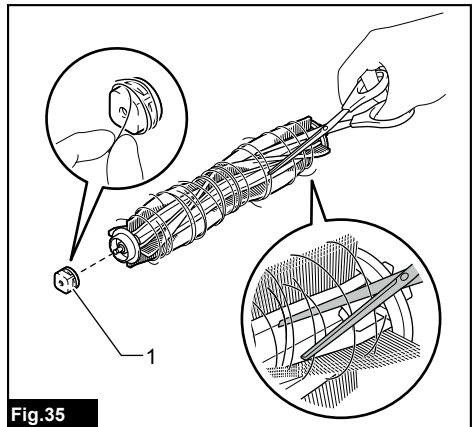
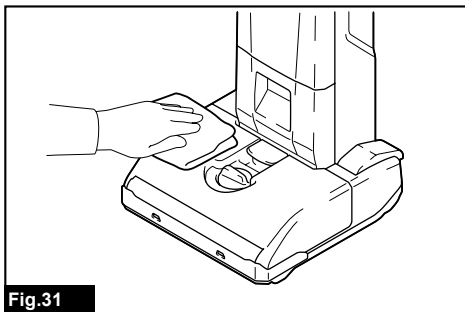
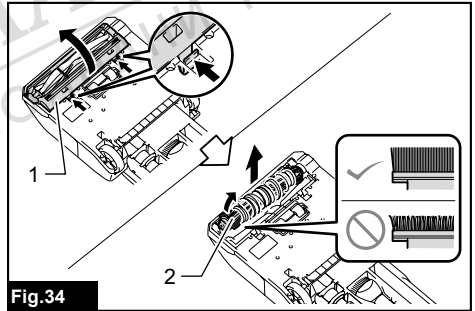
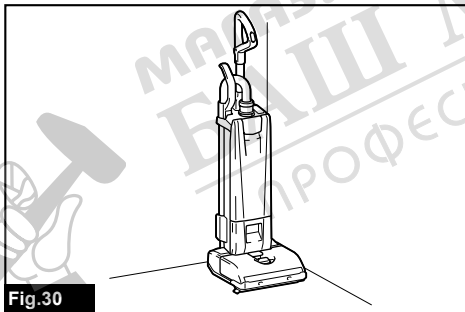
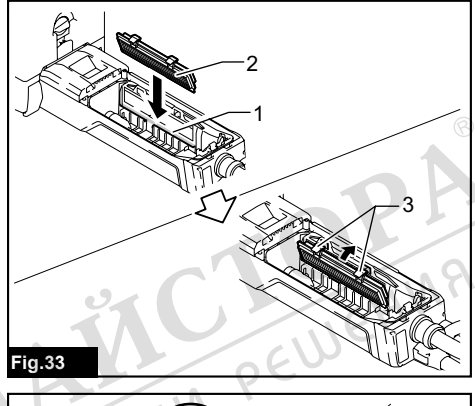
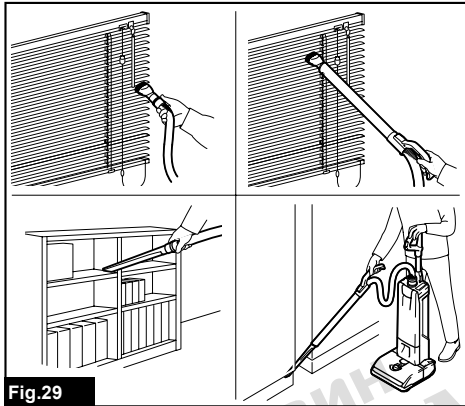
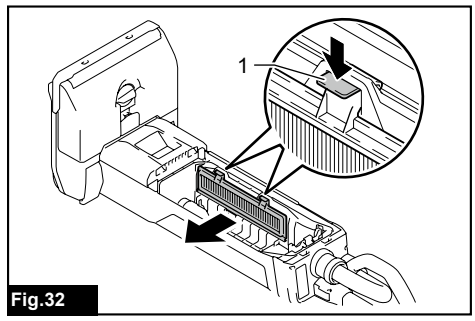
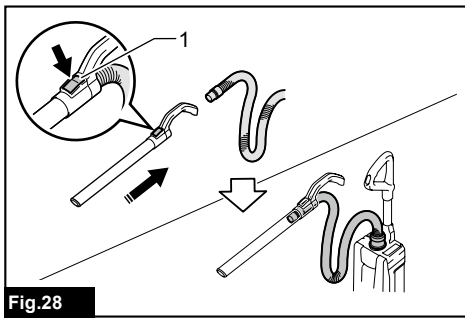
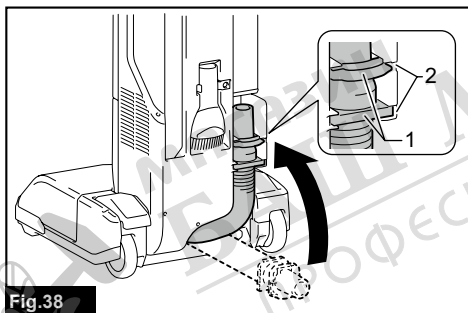
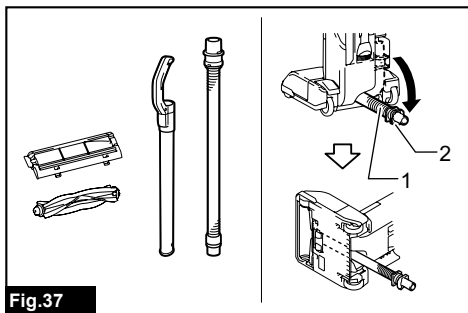
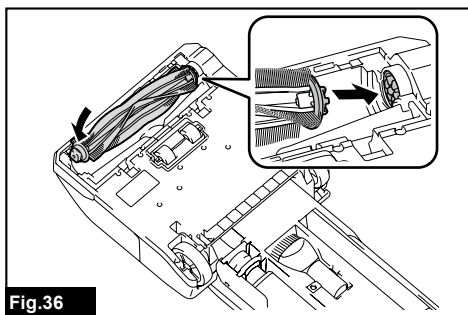

Fig.27





WARNING

- This machine is not intended for use by persons including children with reduced physical, sensory or mental capabilities, or lack of experience and knowledge.
- Children should be supervised to ensure that they do not play with the cleaner.
- See the chapter "SPECIFICATIONS" for the type reference of the battery.
- See the section "Installing or removing battery cartridge" for how to remove or install the battery.
- When disposing the battery cartridge, remove it from the tool and dispose of it in a safe place. Follow your local regulations relating to disposal of battery.
- If the tool is not used for a long period of time, the battery must be removed from the tool.
- Do not short the battery cartridge.
- See the chapter "MAINTENANCE" for the appropriate details of precautions during user maintenance.

SPECIFICATIONS

Model:	DVC560
Maximum air volume *	1.9 m ³ /min
Vacuum *	12 kPa
Capacity	5 L
Dimensions (L x W x H)	326 mm x 318 mm x 1,146 mm
Rated voltage	D.C. 36 V
Net weight	8.3 - 9.0 kg

- * The value is measured by our original method.
- Due to our continuing program of research and development, the specifications herein are subject to change without notice.
- Specifications and battery cartridge may differ from country to country.
- The weight includes accessories (round brush, corner nozzle) and battery cartridge(s). The lightest and heaviest combination weight of the appliance and battery cartridge(s) are shown in the table.

Applicable battery cartridge and charger

Battery cartridge	BL1815N / BL1820B / BL1830B / BL1840B / BL1850B / BL1860B
Charger	DC18RC / DC18RD / DC18RE / DC18SD / DC18SE / DC18SF / DC18SH

- Some of the battery cartridges and chargers listed above may not be available depending on your region of residence.

⚠WARNING: Only use the battery cartridges and chargers listed above. Use of any other battery cartridges and chargers may cause injury and/or fire.

Symbols

The followings show the symbols which may be used for the equipment. Be sure that you understand their meaning before use.



Read instruction manual.



Take particular care and attention.



Only for EU countries
Due to the presence of hazardous components in the equipment, waste electrical and electronic equipment, accumulators and batteries may have a negative impact on the environment and human health. Do not dispose of electrical and electronic appliances or batteries with household waste!
In accordance with the European Directive on waste electrical and electronic equipment and on accumulators and batteries and waste accumulators and batteries, as well as their adaptation to national law, waste electrical equipment, batteries and accumulators should be stored separately and delivered to a separate collection point for municipal waste, operating in accordance with the regulations on environmental protection. This is indicated by the symbol of the crossed-out wheeled bin placed on the equipment.

Intended use

The appliance is intended for collecting dry dust. The appliance is suitable for commercial use, for example in hotels, schools, hospitals, factories, shops, offices and rental businesses.

Noise

The typical A-weighted noise level determined according to IEC60335-2-69:

Sound pressure level (L_{pA}) : 70 dB(A) or less
Uncertainty (K) : 2.5 dB(A)

The noise level under working may exceed 80 dB (A).

NOTE: The declared noise emission value(s) has been measured in accordance with a standard test method and may be used for comparing one tool with another.

NOTE: The declared noise emission value(s) may also be used in a preliminary assessment of exposure.

⚠ WARNING: Wear ear protection.

⚠ WARNING: The noise emission during actual use of the power tool can differ from the declared value(s) depending on the ways in which the tool is used especially what kind of workpiece is processed.

⚠ WARNING: Be sure to identify safety measures to protect the operator that are based on an estimation of exposure in the actual conditions of use (taking account of all parts of the operating cycle such as the times when the tool is switched off and when it is running idle in addition to the trigger time).

Vibration

The vibration total value (tri-axial vector sum) determined according to IEC60335-2-69:

Vibration emission (a_{hM}) : 2.5 m/s² or less

Uncertainty (K) : 1.5 m/s²

NOTE: The declared vibration total value(s) has been measured in accordance with a standard test method and may be used for comparing one tool with another.

NOTE: The declared vibration total value(s) may also be used in a preliminary assessment of exposure.

⚠ WARNING: The vibration emission during actual use of the power tool can differ from the declared value(s) depending on the ways in which the tool is used especially what kind of workpiece is processed.

⚠ WARNING: Be sure to identify safety measures to protect the operator that are based on an estimation of exposure in the actual conditions of use (taking account of all parts of the operating cycle such as the times when the tool is switched off and when it is running idle in addition to the trigger time).

EC Declaration of Conformity

For European countries only

The EC declaration of conformity is included as Annex A to this instruction manual.

SAFETY WARNINGS

Cordless vacuum cleaner safety warnings

⚠ WARNING: IMPORTANT! READ CAREFULLY all safety warnings and all instructions BEFORE USE. Failure to follow the warnings and instructions may result in electric shock, fire and/or serious injury.

1. **Before use, make sure that this cleaner must be used by people who have been adequately instructed on the use of this cleaner.**
2. **Do not use without filter bag and/or filters in place. Replace a damaged filter immediately.**
3. **AVOID UNINTENTIONAL STARTING.** Be sure switch is OFF when installing battery(ies).
4. **Do not attempt to pick up flammable materials, fire works, lighted cigarettes, hot ashes, hot metal chips, sharp materials such as razors, needles, broken glass or the like.**
5. **NEVER USE THE CLEANER IN THE VICINITY OF GASOLINE, GAS, PAINT, ADHESIVES OR OTHER HIGHLY EXPLOSIVE SUBSTANCES.** The switch emits sparks when turned ON and OFF. And so does the motor commutator during operation. A dangerous explosion may result.

6. This cleaner is not suitable for picking up hazardous dust.
 7. Never vacuum up toxic, carcinogenic, combustible or other hazardous materials such as asbestos, arsenic, barium, beryllium, lead, pesticides, or other health endangering materials.
 8. Do not use outdoors or on wet surfaces.
 9. For Finland, this machine is not to be used outdoors at low temperature.
 10. Do not use the appliance close to heat sources (stoves, etc.).
 11. Do not block suction inlet/outlet/cooling vents. These vents permit cooling of the motor. Blockage should be carefully avoided otherwise the motor will burn out due to a lack of ventilation.
 12. Do not fold, tug or step on the hose.
 13. Stop the cleaner immediately if you notice poor performance or anything abnormal during operation.
 14. REMOVE THE BATTERY(IES). When not in use, before servicing, and when changing accessories.
 15. Clean and service the cleaner immediately after each use to keep it in optimum operating condition.
 16. MAINTAIN THE CLEANER WITH CARE. Keep the cleaner clean for better and safer performance. Follow instructions for changing accessories. Keep handles dry, clean, and free from oil and grease.
 17. CHECK DAMAGED PARTS. Before further use of the cleaner, a guard or other part that is damaged should be carefully checked to determine that it will operate properly and perform its intended function. Check for alignment of moving parts, binding of moving parts, breakage of parts, mounting, and any other conditions that may affect its operation. A guard or other part that is damaged should be properly repaired or replaced by an authorized service center unless otherwise indicated elsewhere in this instruction manual. Have defective switches replaced by authorized service center. Don't use the cleaner if switch does not turn it on and off.
 18. REPLACEMENT PARTS. When servicing, use only identical replacement parts.
 19. When not in use, always store the cleaner indoors.
 20. Be kind to your cleaner. Rough handling can cause breakage of even the most sturdily built cleaner.
 21. Do not attempt to clean the exterior or interior with benzine, thinner or cleaning chemicals. Cracks and discoloration may be caused.
 22. Do not use cleaner in an enclosed space where flammable, explosive or toxic vapors are given off by oil-base paint, paint-thinner, gasoline, some mothproofing substances, etc., or in areas where flammable dust is present.
 23. Do not operate the cleaner or any tool while under the influence of drugs or alcohol.
 24. Wear appropriate protective equipment such as a mask depending on the usage environment.
 25. This machine is not intended for use by persons including children with reduced physical, sensory or mental capabilities, or lack of experience and knowledge.
 26. Children should be supervised to ensure that they do not play with the cleaner.
 27. Never handle battery(ies) and cleaner with wet hands.
 28. Use extreme caution when cleaning on stairs.
 29. Keep proper footing and balance at all times.
 30. Do not use the cleaner as a stool or work bench. The machine may fall down and may result in personal injury.
 31. Keep all parts of your body and clothing away from the openings and moving part like the rotating brushroll. Otherwise they may be caught in the appliance and cause injury.
- Battery tool use and care**
1. Recharge only with the charger specified by the manufacturer. A charger that is suitable for one type of battery pack may create a risk of fire when used with another battery pack.
 2. Use power tools only with specifically designed battery packs. Use of any other battery packs may create a risk of injury and fire.
 3. When battery pack is not in use, keep it away from other metal objects, like paper clips, coins, keys, nails, screws or other small metal objects, that can make a connection from one terminal to another. Shorting the battery terminals together may cause burns or a fire.
 4. Under abusive conditions, liquid may be ejected from the battery; avoid contact. If contact accidentally occurs, flush with water. If liquid contacts eyes, additionally seek medical help. Liquid ejected from the battery may cause irritation or burns.
 5. Do not use a battery pack or tool that is damaged or modified. Damaged or modified batteries may exhibit unpredictable behaviour resulting in fire, explosion or risk of injury.
 6. Do not expose a battery pack or tool to fire or excessive temperature. Exposure to fire or temperature above 130 °C may cause explosion.
 7. Follow all charging instructions and do not charge the battery pack or tool outside the temperature range specified in the instructions. Charging improperly or at temperatures outside the specified range may damage the battery and increase the risk of fire.
- SAVE THESE INSTRUCTIONS.**
- ▲WARNING: DO NOT** let comfort or familiarity with product (gained from repeated use) replace strict adherence to safety rules for the subject product. MISUSE or failure to follow the safety rules stated in this instruction manual may cause serious personal injury.

Important safety instructions for battery cartridge

1. Before using battery cartridge, read all instructions and cautionary markings on (1) battery charger, (2) battery, and (3) product using battery.
2. Do not disassemble or tamper with the battery cartridge. It may result in a fire, excessive heat, or explosion.
3. If operating time has become excessively shorter, stop operating immediately. It may result in a risk of overheating, possible burns and even an explosion.
4. If electrolyte gets into your eyes, rinse them out with clear water and seek medical attention right away. It may result in loss of your eyesight.
5. Do not short the battery cartridge:
 - (1) Do not touch the terminals with any conductive material.
 - (2) Avoid storing battery cartridge in a container with other metal objects such as nails, coins, etc.
 - (3) Do not expose battery cartridge to water or rain.

A battery short can cause a large current flow, overheating, possible burns and even a breakdown.
6. Do not store and use the tool and battery cartridge in locations where the temperature may reach or exceed 50 °C (122 °F).
7. Do not incinerate the battery cartridge even if it is severely damaged or is completely worn out. The battery cartridge can explode in a fire.
8. Do not nail, cut, crush, throw, drop the battery cartridge, or hit against a hard object to the battery cartridge. Such conduct may result in a fire, excessive heat, or explosion.
9. Do not use a damaged battery.
10. The contained lithium-ion batteries are subject to the Dangerous Goods Legislation requirements.

For commercial transports e.g. by third parties, forwarding agents, special requirement on packaging and labeling must be observed.
For preparation of the item being shipped, consulting an expert for hazardous material is required.
Please also observe possibly more detailed national regulations.
Tape or mask off open contacts and pack up the battery in such a manner that it cannot move around in the packaging.
11. When disposing the battery cartridge, remove it from the tool and dispose of it in a safe place. Follow your local regulations relating to disposal of battery.
12. Use the batteries only with the products specified by Makita. Installing the batteries to non-compliant products may result in a fire, excessive heat, explosion, or leak of electrolyte.
13. If the tool is not used for a long period of time, the battery must be removed from the tool.

14. During and after use, the battery cartridge may take on heat which can cause burns or low temperature burns. Pay attention to the handling of hot battery cartridges.
15. Do not touch the terminal of the tool immediately after use as it may get hot enough to cause burns.
16. Do not allow chips, dust, or soil stuck into the terminals, holes, and grooves of the battery cartridge. It may result in poor performance or breakdown of the tool or battery cartridge.
17. Unless the tool supports the use near high-voltage electrical power lines, do not use the battery cartridge near high-voltage electrical power lines. It may result in a malfunction or breakdown of the tool or battery cartridge.
18. Keep the battery away from children.

SAVE THESE INSTRUCTIONS.

CAUTION: Only use genuine Makita batteries. Use of non-genuine Makita batteries, or batteries that have been altered, may result in the battery bursting causing fires, personal injury and damage. It will also void the Makita warranty for the Makita tool and charger.

Tips for maintaining maximum battery life

1. Charge the battery cartridge before completely discharged. Always stop tool operation and charge the battery cartridge when you notice less tool power.
2. Never recharge a fully charged battery cartridge. Overcharging shortens the battery service life.
3. Charge the battery cartridge with room temperature at 10 °C - 40 °C (50 °F - 104 °F). Let a hot battery cartridge cool down before charging it.
4. When not using the battery cartridge, remove it from the tool or the charger.
5. Charge the battery cartridge if you do not use it for a long period (more than six months).

PARTS DESCRIPTION

► Fig.1

1	Handle	2	Switch plate	3	Pipe grip	4	Hose
5	Indication panel	6	Lever (for the dust box cover)	7	Dust box cover	8	Carrying handle
9	Lock (for battery cover)	10	Adjusting lever	11	Battery cover	12	Corner nozzle
13	Round brush	14	Foot lever	15	Caster wheel	16	Side brush
17	Suction hose	18	Joint	19	Aluminum pipe	20	Pipe holder
21	LED lamp	22	Brushroll	23	Bottom plate	24	ON / mode change button
25	OFF button	26	Indicator of operating mode	27	Indicator of excess level of dust	28	Indicator of brushroll error
29	Indicator for remaining battery capacity	30	Battery check / LED lamp button	-	-	-	-

ASSEMBLY

CAUTION: Always be sure that the appliance is switched off and the battery cartridge is removed before carrying out any work on the appliance.

CAUTION: Always wear dust mask during assembly or maintenance.

Handle connecting

1. Insert the handle pole fully to the cleaner body as shown in the figure.
2. Close the lock latch.

► Fig.2: 1. Handle pole 2. Red marking 3. Lock latch

NOTICE: Insert the handle fully until the red marking cannot be seen.

Hose connecting

Insert the hose into the mounting port of the appliance and turn the horse until it locks.

► Fig.3

Pipe connecting

Insert the tip of the aluminum pipe to the joint, and then attach the aluminum pipe to the pipe holder.

► Fig.4: 1. Joint 2. Pipe holder

NOTICE: Insert the aluminum pipe in correct direction as shown in figure. Otherwise the pipe holder will not be locked and the aluminum pipe may come off.

► Fig.5

Installing or removing battery cartridge

CAUTION: Always switch off the appliance before installing or removing of the battery cartridge.

CAUTION: Hold the cleaner and the battery cartridge firmly when installing or removing battery cartridge. Failure to hold the cleaner and the battery cartridge firmly may cause them to slip off your hands and result in damage to the cleaner and battery cartridge and a personal injury.

CAUTION: Be careful not to pinch your fingers when opening or closing the battery cover. Failure to do so may cause personal injury.

To install the battery cartridge, release the lock first, and then open the battery cover. After that, insert the battery cartridge.

► Fig.6: 1. Lock 2. Battery cover

Align the tongue on the battery cartridge with the groove in the housing and slip it into place. Insert it all the way until it locks in place with a little click. Then lock the battery cover.

► Fig.7: 1. Battery cartridge 2. Button

To remove the battery cartridge, slide it from the appliance while sliding the button in front of the cartridge.

CAUTION: Always install the battery cartridge fully. If not, it may accidentally fall out of the appliance, causing injury to you or someone around you.

CAUTION: Do not install the battery cartridge forcibly. If the cartridge does not slide in easily, it is not being inserted correctly.

NOTE: The cleaner does not work with only one battery cartridge.

Installing the filter bag

CAUTION: Do not use a damaged filter bag. Always use the vacuum cleaner with the filter bag properly installed. Otherwise the vacuumed dust or particles may be exhausted from the cleaner and they may cause respiratory disease to the operator.

Install the filter bag before using cleaner.
Filter bag is a throw-away type. Throw away the entire filter bag without emptying when it has become full.

NOTICE: When the filter bag is already full or clogged, replace with new one. Continuous use with the filter bag full or clogged results in reduced suction power.

NOTICE: To prevent dust from getting into the motor:

- Make sure that the filter bag is installed before use.
- Do not use a broken or ripped bag.

Otherwise the motor may be broken.

NOTICE: Do not fold the cardboard at its opening when installing the filter bag.

NOTICE: The filter bag for the cleaner is an important component for maintaining the appliance performance. Using non-genuine filter bag may cause smoke or ignition.

NOTE: When the filter bag is not installed in the appliance, the dust box cover does not close completely.

1. Unlock the lever and open the dust box cover.
▶ Fig.8: 1. Lever 2. Dust box cover
2. Unfold the filter bag fully.
▶ Fig.9
3. Insert the filter bag into the slot on the holder so that the side with mark \triangle enters first.
4. Hook the latch of the holder.
▶ Fig.10: 1. Slot 2. Filter bag 3. Holder 4. Latch
5. Make sure that only the marking on the cardboard can be seen through the slit of the holder.
▶ Fig.11: 1. Marking 2. Slit
6. Unfold the filter bag if it is folded.
▶ Fig.12
7. Lock the dust box cover certainly.

CAUTION: Be careful not to pinch your fingers when hooking the latch, and when closing the dust box cover.

Removing the filter bag

CAUTION: Handle the filter bag softly. Otherwise foreign objects are blown into eyes, it may result in personal injury.

Replace the filter bag when it becomes full or clogged. Open the dust box cover and open the latch, then take out the filter bag.

Pull the strip on the side of the opening to shut the filter bag and dispose of the filter bag in whole.

▶ Fig.13: 1. Latch 2. Strip

NOTICE: Do not use a used filter bag. The filter bag is designed for single use. Using filter bag repeatedly may cause clogging of the filter and results in damage to the appliance.

FUNCTIONAL DESCRIPTION

CAUTION: Always be sure that the appliance is switched off and the battery cartridge is removed before adjusting or checking function on the appliance.

Tool / battery protection system

The tool is equipped with a tool/battery protection system. This system automatically cuts off power to the motor to extend tool and battery life. The tool will automatically stop during operation if the tool or battery is placed under one of the following conditions:

Overload protection

When the tool is operated in a manner that causes it to draw an abnormally high current, the tool automatically stops without any indication. In this situation, turn the tool off and stop the application that caused the tool to become overloaded. Then turn the tool on to restart.

Overheat protection

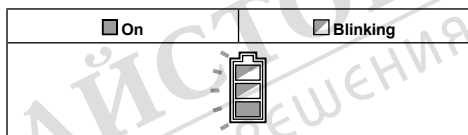

When the tool is overheated, the tool stops automatically, and the battery indicator blinks about 60 seconds. In this situation, let the tool cool down before turning the tool on again.

Overdischarge protection

When the battery capacity becomes low, the tool stops automatically. If the product does not operate even when the switches are operated, remove the batteries from the tool and charge the batteries.







Indicating the remaining battery capacity

Only for battery cartridges with the indicator

▶ Fig.14: 1. Indicator lamps 2. Check button

Press the check button on the battery cartridge to indicate the remaining battery capacity. The indicator lamps light up for a few seconds.

Indicator lamps			Remaining capacity
Lighted	Off	Blinking	
■ ■ ■ ■			75% to 100%
■ ■ ■ □			50% to 75%
■ ■ □ □			25% to 50%
■ □ □ □			0% to 25%
▣ □ □ □			Charge the battery.

Indicator lamps			Remaining capacity
Lighted	Off	Blinking	
			The battery may have malfunctioned.
			

NOTE: Depending on the conditions of use and the ambient temperature, the indication may differ slightly from the actual capacity.

NOTE: The first (far left) indicator lamp will blink when the battery protection system works.

Indication panel

- **Fig.15:** 1. Operating mode 2. Excess level of dust 3. Brushroll error 4. Remaining battery capacity 5. Battery check / LED lamp button

Operating mode

To change the operating mode, refer to the section for switch action.

Excess level of dust

If this indicator lights up, replace the filter bag. (Refer the section of removing the filter bag.)

NOTE: This indicator does not work when the appliance operates in "lower noise level (1)" mode.

NOTE: This indicator may not work depending on the usage environment.

NOTE: The indicator automatically goes out approximately one minute after the appliance is switched off. If you clear the clogging of the filter bag and restart the appliance, the indicator goes out even within one minute.

Brushroll error









Blinking	The brushroll is under high load for some reasons.
On	The brushroll is stopped by abnormal reason.

⚠WARNING: Immediately switch off the appliance when this lamp lights up during operation. Otherwise the motor malfunction may occur and cause fire.

Remaining battery capacity

During operation, press the battery check / LED lamp button to indicate the remaining battery capacities. The battery indicators correspond to each battery.

► **Fig.16**

Battery indicator status			Remaining battery capacity
On	Off	Blinking	
			50% to 100%
			
			Charge the battery

Battery check / LED lamp button

During operation, the following operations can be performed.

- Simply press the button to check the remaining battery capacity.
- Press and hold the button to turn on / off the LED lamp.

Switch action

► **Fig.17:** 1. ON / mode change button 2. OFF button

Turning on / off the appliance

To start the appliance, simply push the ON / mode change button. To switch off, push the OFF button.

⚠CAUTION: Always put the head of the appliance on the floor when turning on the appliance. Otherwise an accident due to entanglement may occur and cause a personal injury.

Changing operating mode

You can change the operating mode in three steps: "lower noise level (1)", "normal (2)", and "high (3)". If you want to change operating mode, press the ON / mode change button when the appliance is running. The operating mode switches in order "lower noise level (1)", "normal (2)", and "high (3)". The appliance will start in the same mode as the previous setting.

Lighting up the LED lamp

⚠ CAUTION: Do not look in the light or see the source of light directly.

The appliance is equipped with the LED lamps. See the paragraph of the battery check / LED lamp button for operation.

► Fig.18: 1. LED lamp

Foot lever

⚠ CAUTION: Always lock the appliance in upright position when you let go of the handle. Otherwise the appliance may accidentally fall and cause injury.

⚠ CAUTION: Be careful not to pinch your fingers between the main body and the head of the appliance.

To unlock the upright position of the appliance, step on the foot lever and pull the handle backward.

The range of motion is 90 degrees from the upright position.

► Fig.19: 1. Foot lever

To lock the appliance in upright position, raise up the handle forward until the foot lever locks the position with click.

► Fig.20

NOTE: While the appliance is in the upright position, the brushroll stops rotating.

Adjusting the height of brushroll

⚠ CAUTION: Always make sure that the adjusting lever comes into the position properly before operation.

The height of brushroll can be adjusted in 4 steps.

Turn the adjusting lever to your desired height.

When the adjusting lever points the A mark, the brushroll is located at the lowest point above the floor and is suitable for cleaning hard floors and short-haired carpets. When the adjusting lever points the B mark, the brushroll is located at the highest point above the floor and is suitable for cleaning long-haired carpets.

► Fig.21: 1. Adjusting lever

NOTE: The brushroll may not rotate if the height of brushroll is too low against the surface of the carpet.

Carrying handle

When carrying the appliance, push the appliance with the caster wheels only, or carry it by holding the carrying handle(s).

► Fig.22

⚠ CAUTION: When carrying the appliance, lock the appliance in upright position. Otherwise falling accident may occur.

⚠ CAUTION: Do not carry the appliance with anything other than the carrying handle. Otherwise falling accident may occur or unintentional starting may cause an injury.

► Fig.23

OPERATION

⚠ CAUTION: Do not pull out the handle pole from the appliance during operation. Doing so lose control of the appliance and may result serious injury.

⚠ CAUTION: Do not put your hand or leg under the appliance during operation. Otherwise pinching accident may occur.

Normal cleaning operation

1. Hold the handle, and then unlock the upright position.
2. Turn on the appliance. Clean a floor.

► Fig.24

Using the side brush

The side brush is convenient for cleaning the corner of a wall. If the side brush gets short, take the appliance to the Makita service center for replacement

► Fig.25: 1. Side brush

Operation with accessories

⚠ CAUTION: Keep holding the handle when using accessories. Otherwise the appliance may accidentally fall and cause injury.

NOTICE: When using accessories, lock the appliance in upright position. Otherwise the rotation of the brushroll may damage the floor.

Using the aluminum pipe

The aluminum pipe is suitable for cleaning tight quarters, or high places.

► Fig.26: 1. Aluminum pipe

Using the hose

The hose is suitable for cleaning near your hands.

► Fig.27: 1. Hose

To use the hose, pull out the aluminum pipe from the hose while pushing the lever.

To install the hose, insert the hose into the aluminum pipe until it clicks.

► Fig.28: 1. Lever

Using the attachments

► Fig.29

To install the attachment, twist and insert it securely to the aluminum pipe or the hose. To disconnect, twist and remove it.

MAINTENANCE

CAUTION: Always be sure that the appliance is switched off and the battery cartridge is removed before attempting to perform inspection or maintenance.

NOTICE: Never use gasoline, benzine, thinner, alcohol or the like. Discoloration, deformation or cracks may result.

To maintain product SAFETY and RELIABILITY, repairs, any other maintenance or adjustment should be performed by Makita Authorized or Factory Service Centers, always using Makita replacement parts.

Storage

When storing, remove the battery cartridges and store the appliance on level place in upright position.

► Fig.30

Cleaning the appliance body

From time to time wipe off the outside (cleaner body) of the cleaner using a cloth dampened in soapy water.

► Fig.31

Cleaning the HEPA filter

CAUTION: Do not use the cleaner without a filter or continue to use dirty or damaged filter. Vacuumed dust or particles may be exhausted from the cleaner and they may cause respiratory disease to the operator.

NOTICE: To keep optimum suction power and clean exhaust, clean the filter periodically. If enough suction power is not obtained even after the cleaning, replace the filter with new one.

NOTICE: To prevent the filter from being damaged, do not use following tools and similar items for cleaning :

- Air duster
- High pressure washer
- Tools made of hard materials such as a metallic brush

1. Open the dust box cover and take out the filter bag.

Release the hooks on the filter and remove it from the appliance body.

► Fig.32: 1. Hook

2. Beat the dust off from the filter. The filter can be washed with water. Rinse away the dust and particles on the filter every 1 or 2 month. After that, dry the filter completely in a shaded and well-ventilated place to prevent unpleasant odor or malfunctions.

3. To install the filter, insert the side without the hooks into the groove then push in the filter until the hooks are secured with a click.

► Fig.33: 1. Groove 2. HEPA filter 3. Hook

Cleaning the brushroll

1. Remove the bottom plate, and then remove the brushroll.

If the hair of the brushroll gets short, ask the Makita service center for new one.

Operating the appliance with the short hair brushroll results in poor dust collecting.

► Fig.34: 1. Bottom plate 2. Brushroll

2. Remove threads and hairs from the brushroll using scissors.

Remove the cap and clean debris.

► Fig.35: 1. Cap

3. Install the cap, brushroll, and bottom plate in reverse order.

► Fig.36

CAUTION: Attach the bottom plate completely. If the appliance is operated without the bottom plate, the brushroll may come off and cause injury.

NOTICE: Always attach the brushroll. Operating the appliance without the brushroll results in poor dust collecting.

How to clear the clog

NOTICE: Do not operate the appliance with the intake flow path clogged. Continuous use with the intake flow path clogged results in reduced suction power.

1. Remove the bottom plate, and then remove the brushroll.

2. Remove the aluminum pipe from the appliance and from the hose.

3. Turn the hose counterclockwise, and then remove the hose from the appliance.

4. Remove the suction hose by pulling the tab.

► Fig.37: 1. Suction hose 2. Tab

5. Inspect the intake flow path of air for the inside of the aluminum pipe and the hose, and the suction hose. Clean debris inside of them.

6. Align the tongue of the suction hose with the groove in the housing and slip it into place.

► Fig.38: 1. Tongue 2. Groove

7. Install the hose, aluminum pipe, brushroll, and bottom plate.

CAUTION: Install the hose, pipe firmly. Otherwise dust leakage may occur and cause injury.