

metabo®

PROFESSIONAL POWER TOOL SOLUTIONS

W 850-100
W 850-115
W 850-125
WP 850-115
WP 850-125
WEV 850-125

W 1100-115
W 1100-125
WP 1100-115

WQ 1100-125

WEQ 1400-125



de Originalbetriebsanleitung 5
en Original instructions 13
fr Notice originale 20
nl Oorspronkelijke gebruiksaanwijzing 28
it Istruzioni originali 36
es Manual original 44
pt Manual original 52
sv Bruksanvisning i original 60

fi Alkuperäiset ohjeet 66
no Original bruksanvisning 73
da Original brugsanvisning 80
pl Instrukcja oryginalna 87
el Πρωτότυπο οδηγιών λειτουργίας 95
hu Eredeti használati utasítás 103
ru Оригинальное руководство по эксплуатации 111

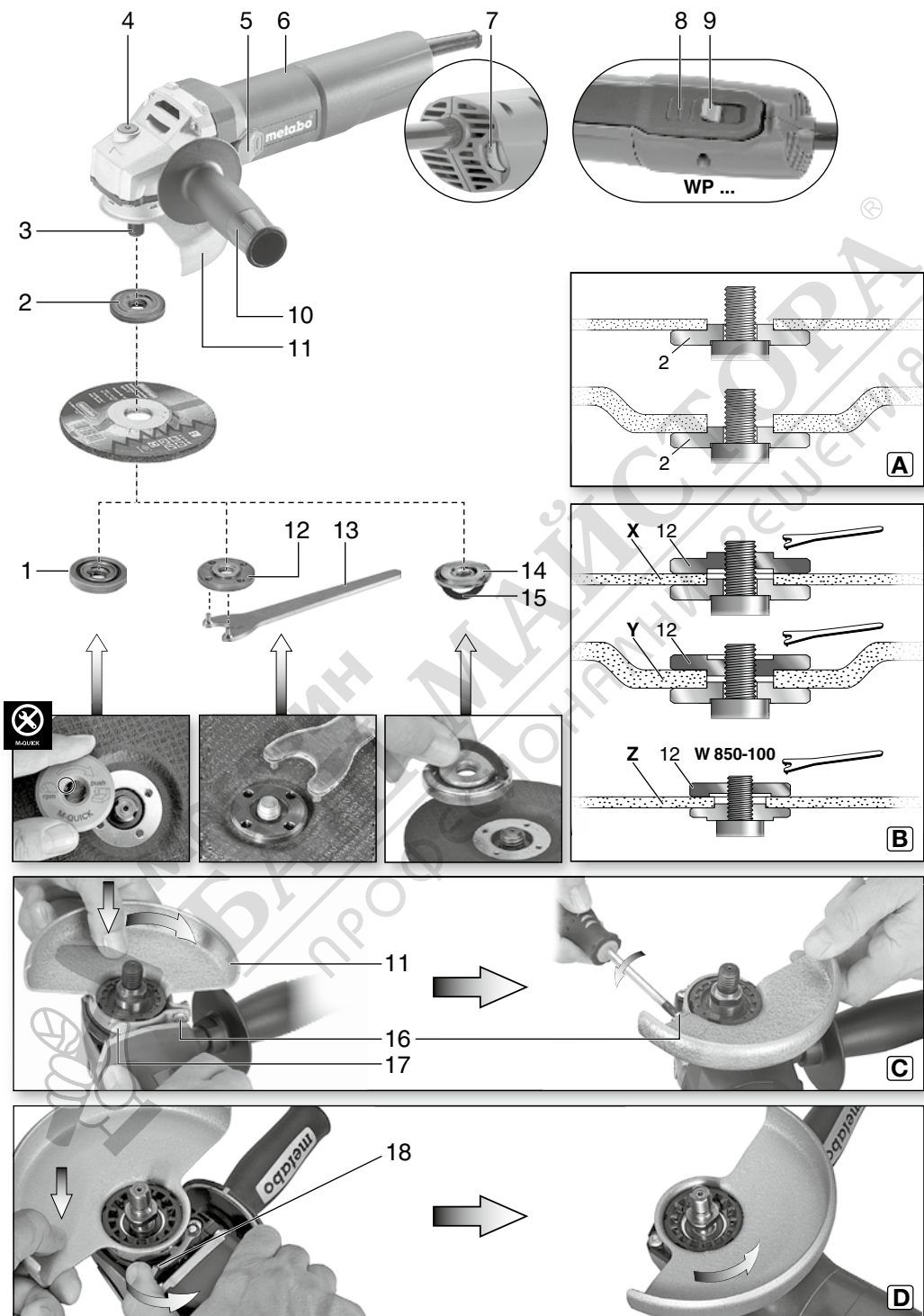

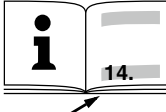
|  | | W 850-100 *1) 03606.. | W 850-115 *1) 03607.. | W 850-125 *1) 03608.. | WP 850-115 *1) 03609.. | WP 850-125 *1) 03610.. | WEV 850-125 *1) 03611.. | W 1100-115 *1) 03613.. | W 1100-125 *1) 03614.. | WP 1100-115 *1) 03612.. | WQ 1100-125 *1) 10035.. | WEQ 1400-125 *1) 00347.. |
|--|----------------------------|--|---|--------------------------|---------------------------|---------------------------|----------------------------|---|---------------------------|----------------------------|--------------------------------------|-----------------------------|
| Quick | | - | - | - | - | - | - | - | - | - | ✓ | ✓ |
| ∅ | mm (in) | 100 (4) | 115 (4 1/2) | 125 (5) | 115 (4 1/2) | 125 (5) | 125 (5) | 115 (4 1/2) | 125 (5) | 115 (4 1/2) | 125 (5) | 125 (5) |
| t _{max1} | mm (in) | 7,1 (⁹ / ₃₂) | | | | | | 10 (³ / ₈) | | | | |
| t _{max2} | mm (in) | - | - | - | - | - | - | - | - | - | 7,1 (⁹ / ₃₂) | |
| t _{max3} | mm (in) | 6 (¹ / ₄) | | | | | | | | | | |
| t _{max4} | mm (in) | 7,1 (⁹ / ₃₂) | | | | | | | | | | |
| M / l | - / mm (in) | M 10 / 19,5 (³ / ₄) | M 14 / 19,5 (³ / ₄) | | | | | M 14 / 20 (²⁵ / ₃₂) | | | | |
| n | min ⁻¹ (rpm) | 11500 | | | | | | 12000 | | | | 11500 |
| n _v | min ⁻¹ (rpm) | - | - | - | - | - | 3000 - 11500 | - | - | - | - | - |
| P ₁ | W | 850 | 850 | 850 | 850 | 850 | 850 | 1100 | 1100 | 1100 | 1100 | 1400 |
| P ₂ | W | 520 | | | | | 480 | 700 | 700 | 700 | 700 | 780 |
| m | kg (lbs) | 1,8 (4.0) | | | | | 1,9 (4.2) | 2,1 (4.7) | | 2,2 (4.8) | | |
| a _{h,SG} / K _{h,SG} | m/s ² | 7,5/1,5 | 7,5/1,5 | 8,0/1,5 | 7,5/1,5 | 8,0/1,5 | 8,0/1,5 | 7,0/1,5 | 7,5/1,5 | 7,0/1,5 | 7,5/1,5 | 7,5/1,5 |
| a _{h,DS} / K _{h,DS} | m/s ² | <2,5/1,5 | | | | | | | | | | |
| L _{pA} /K _{pA} | dB(A) | 88/3 | | | 87/3 | | 88/3 | | | 87/3 | | |
| L _{WA} /K _{WA} | dB(A) | 99/3 | | | 98/3 | | 99/3 | | | 98/3 | | |



*2) 2014/30/EU, 2006/42/EC, 2011/65/EU

*3) EN 60745-1:2009+A11:2010,

EN 60745-2-3:2011+A2:2013+A11:2014+A12:2014+A13:2015, EN 50581:2012

2018-08-16, Bernd Fleischmann

Direktor Produktentstehung & Qualität (Vice President Product Engineering & Quality)

*4) Metabowerke GmbH - Metabo-Allee 1 - 72622 Nuertingen, Germany

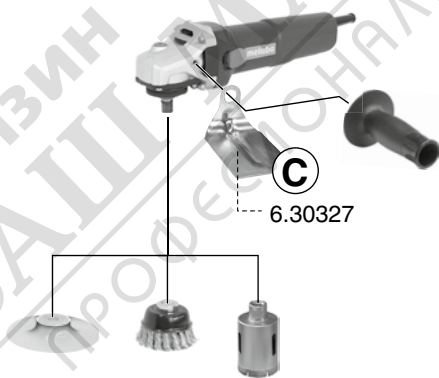
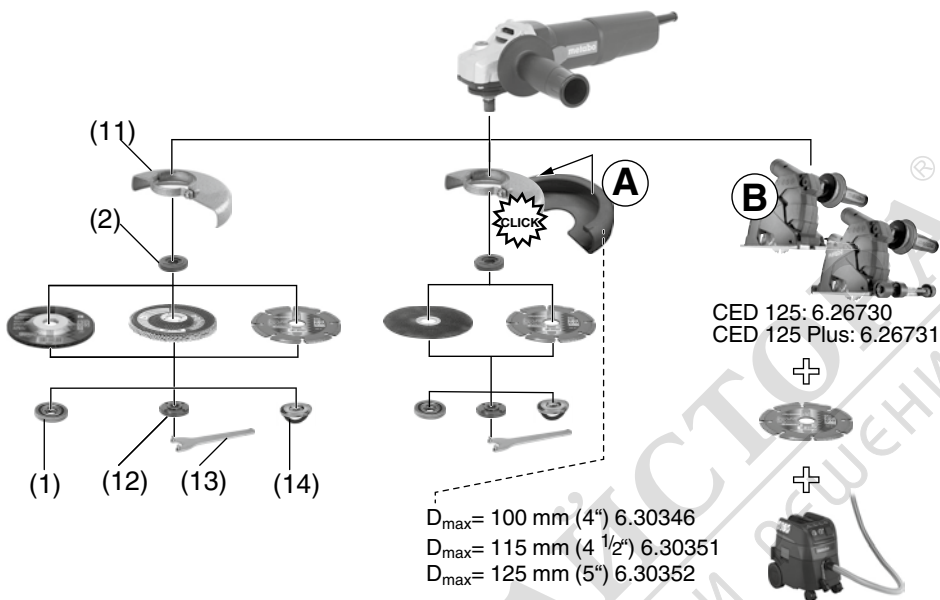

D (12) (M 14) 6.30706
(M 10) 34110205

E (1) WQ 1100-125, WEQ 1400-125: (M 14) 6.30802

F (14) (M 14) 316047600

Original instructions

1. Declaration of Conformity

We, being solely responsible: Hereby declare that these angle grinders, identified by type and serial number *1), meet the requirements of all relevant directives *2) and standards *3). Technical documents for *4) - see page 3.

2. Proper Use

The angle grinders, when fitted with original Metabo accessories, are suitable for grinding, sanding, separating and wire brushing metal, concrete, stone and similar materials without the use of water.

The user bears sole responsibility for any damage caused by inappropriate use.

Generally accepted accident prevention regulations and the enclosed safety information must be observed.

3. General Safety Information



For your own protection and for the protection of your power tool, pay attention to all parts of the text that are marked with this symbol!



WARNING – Read the operating instructions to reduce the risk of injury.



WARNING Read all safety warnings and instructions. *Failure to follow all safety warnings and instructions may result in electric shock, fire and/or serious injury.*

Keep all safety instructions and information for future reference.

Always include these documents when passing on your power tool.

4. Special Safety Instructions

4.1 Safety Warnings Common for Grinding, Sanding, Wire Brushing or Abrasive Cutting-Off Operations:

Use

a) **This power tool is intended to function as a grinder, sander, wire brush or cut-off tool. Read all safety warnings, instructions, illustrations and specifications provided with this power tool.** Failure to follow all the instructions may result in electric shock, fire and/or serious injury.

b) **Operations such as polishing are not recommended to be performed with this power tool.** Operations for which the power tool was not designed may create a hazard and cause personal injury.

c) **Do not use accessories which are not specifically designed and recommended by the tool manufacturer.** Just because the accessory can be

attached to your power tool, it does not assure safe operation.

d) **The rated speed of the accessory must be at least equal to the maximum speed marked on the power tool.** Accessories running faster than their rated speed can break and fly apart.

e) **The outside diameter and the thickness of your accessory must be within the capacity rating of your power tool.** Incorrectly sized accessories cannot be adequately guarded or controlled.

f) **Treaded mounting of accessories must match the grinder spindle thread. For accessories mounted by flanges, the arbour hole of the accessory must fit the locating diameter of the flange.** Accessories that do not match the mounting hardware of the power tool will run out of balance, vibrate excessively and may cause loss of control.

g) **Do not use a damaged accessory. Before each use, inspect accessories such as abrasive wheels for chips and cracks, backing pad for cracks, tear or excess wear, wire brush for loose or cracked wires. If a power tool or accessory is dropped, check it for damage or install an undamaged accessory. After inspecting and installing an accessory, position yourself and bystanders away from the plane of the rotating accessory and run the power tool at maximum no-load speed for one minute.** Damaged accessories will normally break apart during this test time.

h) **Wear personal protective equipment. Depending on application, use a face shield, safety goggles or safety glasses. As appropriate, wear dust mask, hearing protectors, gloves and workshop apron capable of stopping small abrasive or workpiece fragments.** The eye protection must be capable of stopping flying debris generated by various operations. The dust mask or respirator must be capable of filtering particles generated by your operation. Prolonged exposure to high intensity noise may cause hearing loss.

i) **Keep bystanders a safe distance away from work area. Anyone entering the work area must wear personal protective equipment.** Fragments of workpiece or of a broken accessory may fly away and cause injury beyond immediate area of operation.

j) **Hold the power tool by insulated gripping surfaces only, when performing an operation where the cutting accessory may contact hidden wiring or its own cord.** Cutting accessory contacting a "live" wire may make exposed metal parts of the power tool "live" and could give the operator an electric shock.

k) **Position the cord clear of the spinning accessory.** If you lose control, the cord may be cut or snagged and your hand or arm may be pulled into the spinning accessory.

l) **Never lay the power tool down until the accessory has come to a complete stop.** The spinning accessory may grip the surface and pull the power tool out of your control.

m) **Do not run the power tool while carrying it at your side.** Accidental contact with the spinning accessory could snag your clothing, pulling the accessory into your body.

n) **Regularly clean the power tool's air vents.** The motor's fan will draw the dust inside the housing and excessive accumulation of powdered metal may cause electrical hazards.

o) **Do not operate the power tool near flammable materials.** Sparks could ignite these materials.

p) **Do not use accessories that require liquid coolants.** Using water or other liquid coolants may result in electrocution or shock.

4.2 Kickback and Related Warnings

Kickback is a sudden reaction to a pinched or snagged rotating wheel, backing pad, brush or any other accessory. Pinching or snagging causes rapid stalling of the rotating accessory which in turn causes the uncontrolled power tool to be forced in the direction opposite to the accessory's rotation at the point of jamming.

For example, if an abrasive wheel is snagged or pinched by the workpiece, the edge of the wheel that is entering into the pinch point can dig into the surface of the material causing the wheel to climb out or kick out. The wheel may either jump toward or away from the operator, depending on direction of the wheel's movement at the point of pinching. Abrasive wheels may also break under these conditions.

Kickback is the result of power tool misuse and/or incorrect operating procedures or conditions and can be avoided by taking proper precautions as given below.

a) **Maintain a firm grip on the power tool and position your body and arm to allow you to resist kickback forces. Always use the auxiliary handle, if provided, for maximum control over kickback or torque reaction during start-up.** The operator can control torque reactions or kickback forces, if proper precautions are taken.

b) **Never place your hand near the rotating accessory.** Accessory may kickback over your hand.

c) **Do not position your body in the area where power tool will move if kickback occurs.** Kickback will propel the tool in direction opposite to the wheel's movement at the point of snagging

d) **Use special care when working around corners, sharp edges etc. Avoid bouncing and snagging the accessory.** Corners, sharp edges or bouncing have a tendency to snag the rotating accessory and cause loss of control or kickback.

e) **Do not attach a saw chain woodcarving blade or toothed saw blade.** Such blades create frequent kickback and loss of control.

4.3 Safety Warnings Specific for Grinding and Abrasive Cutting-Off Operations:

a) **Use only wheel types that are recommended for your power tool and the specific guard designed for the selected wheel.** Wheels for which the power tool was not designed cannot be adequately guarded and are unsafe.

b) **The grinding surface of the centre depressed wheels must be mounted below the plane of the guard lip.** An improperly mounted wheel that projects through the plane of the guard lip cannot be adequately protected.

c) **The guard must be securely attached to the power tool and positioned for maximum safety, so the least amount of wheel is exposed towards the operator.** The guard helps to protect the operator from broken fragments, accidental contact with the wheel and sparks that could ignite clothing.

d) **Wheels must be used only for recommended applications.**

For example: do not grind with the side of the cut-off wheel. Abrasive cut-off wheels are intended for peripheral grinding, side forces applied to these wheels may cause them to shatter.

e) **Always use undamaged wheel flanges that are of correct size and shape for your selected wheel.** Proper wheel flanges support the wheel thus reducing the possibility of wheel breakage. Flanges for cut-off wheels may be different from grinding wheel flanges.

f) **Do not use worn down wheels from larger power tools.** Wheels intended for larger power tools are not suitable for the higher speed of a smaller tool and may burst.

4.4 Additional Safety Warnings Specific for Abrasive Cutting-Off Operations:

a) **Do not "jam" the cut-off wheel or apply excessive pressure. Do not attempt to make excessively deep cuts.** Overstressing the wheel increases the loading and susceptibility to twisting or binding of the wheel in the cut and the possibility of kickback or wheel breakage.

b) **Do not position your body in line with and behind the rotating wheel.** When the wheel, at the point of operation, is moving away from your body, the possible kickback may propel the spinning wheel and the power tool directly at you.

c) **If the wheel jams or if you interrupt a cut for any reason, switch off the power tool and hold the power tool motionless until the wheel comes to a complete stop. Never attempt to remove the cut-off wheel from the cut while the wheel is in motion, otherwise kickback may occur.** Investigate and take corrective action to eliminate the cause of the wheel jam.

d) **Do not restart the cutting operation in the workpiece. Let the wheel reach full speed and carefully reenter the cut.** The wheel may jam, walk up or kickback if the power tool is restarted in the workpiece.

e) **Support panels or any oversized workpiece to minimise the risk of wheel pinching and kick-**

back. Large workpieces tend to sag under their own weight. Supports must be placed under the workpiece near the line of cut and near the edge of the workpiece on both sides of the wheel.

f) **Use extra caution when making a "pocket cut" into existing walls or other blind areas.** The protruding wheel may cut gas or water pipes, electrical wiring or objects that can cause kickback.

4.5 Safety Warnings Specific for Sanding Operations:

a) **Do not use oversized sanding disc paper. Follow manufacturer's recommendations when selecting sanding paper.** Larger sanding paper extending beyond the sanding pad presents a laceration hazard and may cause snagging, tearing of the disc or kickback.

4.6 Safety Warnings Specific for Wire Brushing Operations:

a) **Be aware that wire bristles are lost by the brush even during ordinary operation. Do not overstress the wires by applying excessive load to the brush.** The wire bristles can easily penetrate light clothing and/or skin.

b) **If the use of a safety guard is recommended for wire brushing, do not allow any interference of the wire wheel or brush with the guard.** Wire wheel or brush may expand in diameter due to work load and centrifugal forces.

4.7 Additional Safety Instructions:

 **WARNING** – Always wear protective goggles.

Use elastic cushioning layers if they have been supplied with the grinding media and if required.

Observe the specifications of the tool or accessory manufacturer! Protect discs from grease or impact!

Grinding wheels must be stored and handled with care in accordance with the manufacturer's instructions.

Never use cut-off wheels for roughing work! Do not apply pressure to the side of cut-off wheels.

The workpiece must lay flat and be secured against slipping, e.g. using clamps. Large workpieces must be sufficiently supported.

If accessories with threaded inserts are used, the end of the spindle may not touch the base of the hole on the sanding tool. Make sure that the thread in the accessory is long enough to accommodate the full length of the spindle. The thread in the accessory must match the thread on the spindle. See page 3 and the 14. Technical Specifications chapter for more information on the spindle length and thread.

It is recommended to use a stationary extraction system and to place a ground fault circuit interrupter (GFCI) downstream. If the angle grinder is shut down via the GFCI, it must be checked and cleaned. See the 9. Cleaning chapter for more information on cleaning the motor.

Damaged, eccentric or vibrating tools must not be used.

Avoid damage to gas or water pipes, electrical cables and load-bearing walls (building structure).

Pull the plug out of the socket before making any adjustments, converting or servicing the machine.

Metabo S-automatic safety clutch (WQ 1100-125, WEQ 1400-125 only). When the safety clutch activates, switch off the machine immediately!

A damaged or cracked additional handle must be replaced. Never operate the machine with a defective additional handle.

A damaged or cracked safety guard must be replaced. Never operate a machine with a defective safety guard.

This power tool is not suitable for polishing work. Improper use of the machine will void the warranty! The motor may overheat and damage the electric power tool. We recommend using our angle polisher for polishing work.

Secure small workpieces, for example by clamping them in a vice.

Reducing dust exposure:

 **WARNING** - Some dust created by power sanding, sawing, grinding, drilling, and other construction activities contains chemicals known to cause cancer, birth defects or other reproductive harm. Some examples of these chemicals are:

- Lead from lead-based paints,
- Crystalline silica from bricks and cement and other masonry products, and
- Arsenic and chromium from chemically treated lumber.

Your risk from these exposures varies, depending on how often you do this type of work. To reduce your exposure to these chemicals: work in a well ventilated area, and work with approved safety equipment, such as those dust masks that are specially designed to filter out microscopic particles.

This also applies to dust from other materials such as some timber types (like oak or beech dust), metals, asbestos. Other known diseases are e.g. allergic reactions, respiratory diseases. Do not let dust enter the body.

Observe the relevant guidelines and national regulations for your material, staff, application and place of application (e.g. occupational health and safety regulations, disposal).

Collect the particles generated at the source, avoid deposits in the surrounding area.

Use suitable accessories for special work. In this way, fewer particles enter the environment in an uncontrolled manner.

Use a suitable extraction unit.

Reduce dust exposure with the following measures:

- do not direct the escaping particles and the exhaust air stream at yourself or nearby persons or on dust deposits,
- use an extraction unit and/or air purifiers,

- ensure good ventilation of the workplace and keep clean using a vacuum cleaner. Sweeping or blowing stirs up dust.
- Vacuum or wash the protective clothing. Do not blow, beat or brush.

5. Overview

See page 2.

- 1 M-Quick clamping nut*
- 2 Support flange *
- 3 Spindle
- 4 Spindle locking button
- 5 Sliding on/off switch *
- 6 Handle
- 7 Speed adjustment wheel *
- 8 Trigger*
- 9 Switch-on lock*
- 10 Side handle
- 11 Safety cover
- 12 2-hole nut *
- 13 2-hole spanner *
- 14 Clamping nut (tool-free) *
- 15 Clip to tighten/release the (tool-free) clamping nut manually *
- 16 Clamping screw*
- 17 Clamping ring*
- 18 Lever for safety guard attachment *

* depending on model / not in scope of delivery

6. Commissioning

 Before commissioning, check that the rated mains voltage and mains frequency stated on the type plate match your power supply.

 Always install an upstream GFCI with a maximum trip current of 30 mA.

6.1 Attaching the additional handle

 Always work with the additional handle (10) attached! Attach the additional handle on the left or right of the machine and secure.

6.2 Attach the safety guard

 For safety reasons, always use the safety guard provided for the respective wheel! See also chapter 11. Accessories!

Safety guard for grinding

Designed for work with roughing wheels, flap sanding pads, diamond cutting discs.

W 850-100, W 850-115, W 850-125, WP 850-115, WP 850-125, WEV 850-125, W 1100-115, W 1100-125 :

See illustration C on page 2.

- Loosen the clamping screw (16) until the clamping ring (17) on the safety guard expands sufficiently.
- Place the safety guard (11) in the position indicated.
- Turn the safety guard until the closed section is facing the operator.

- Tighten the clamping screw (16) firmly. Make sure that the guard is seated securely - you should not be able to turn the safety guard (11).

WP 1100-115, WQ 1100-125, WEQ 1400-125:

See illustration D on page 2.

- Push and hold the lever (18). Place the safety guard (11) in the position indicated.
- Release the lever and rotate the guard until the lever latches.
- Push the lever and turn the safety guard until the closed section is facing the operator.
- Make sure that the guard is attached securely: The lever must engage and you should not be able to turn the safety guard.

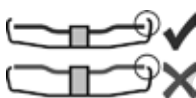

Use only accessories that are covered by at least 3.4 mm by the safety guard.

7. Attaching the grinding wheel

 Prior to any conversion work: pull the mains plug out of the socket. The machine must be switched off and the spindle at a standstill.

 For reasons of safety, attach the cut-off grinding guard before performing cut-off grinding work (see Chapter 11. Accessories).

7.1 Locking the spindle

- Press in the spindle locking button (4) and turn the spindle (3) by hand until the spindle locking button engages.

7.2 Placing the grinding wheel in position

See illustration A on page 2.

- Fit the support flange (2) on the spindle. The flange should not turn on the spindle when properly attached.
Only W 850-100: Screw support flange with two-hole spanner onto spindle so that the small collar (with diameter 16 mm) is facing upwards.
- Place the grinding wheel on the support flange (2). The grinding wheel must lay flat on the supporting flange.

7.3 Securing/Releasing the "M-Quick" clamping nut (depending on features)

Securing the "M-Quick" clamping nut (1):

 Only for WQ1100-125; WEQ 1400-125.

 Do not use the "M-Quick" clamping nut if the accessory has a clamping shank thicker than 7,1 mm! In this case, use the 2-hole nut (12) with 2-hole spanner (13).

- Lock the spindle (see chapter 7.1).
- Position the "M-Quick" clamping nut (1) on the spindle (3) so that the 2 lugs engage in the 2 grooves on the spindle. See illustration on page 2.
- Tighten the "M-Quick" clamping nut by turning it clockwise by hand.

- Turn the grinding wheel firmly clockwise to tighten the "M-Quick" clamping nut.

Releasing the "M-Quick" clamping nut (1):

 The "M-Quick" clamping nut (1) must be attached before the spindle locking button (4) can hold the spindle!

- The machine continues to run after switching off.
- Press in the spindle locking button (4) just before the grinding wheel stops. The "M-Quick" clamping nut (1) is released.

7.4 Securing/Releasing the 2-hole nut (depending on features)

Securing the 2-hole nut (12):

The 2 sides of the two-hole nut are different. Screw the two-hole nut onto the spindle as follows: See illustration B on page 2.

- X) For thin grinding discs:

The edge of the 2-hole nut (12) faces upwards so that the thin grinding disc can be attached securely.

Y) For thick grinding discs:

The edge of the two-hole nut (12) faces downwards so that the two-hole nut can be attached securely to the spindle.

Z) Only for W 850-100:

The collar of the two-hole nut faces downwards and/or the flat surface faces upwards.

- Lock the spindle. Turn the two-hole nut (12) clockwise using the two-hole spanner (13) to secure.

Releasing the 2-hole nut:

- Lock the spindle (see chapter 7.1). Turn the two-hole nut (12) anticlockwise using the two-hole spanner (13) to unscrew.

7.5 Securing/releasing the (tool-free) clamping nut (depending on features)

 Only tighten the (tool-free) clamping nut (14) by hand!

 For the machine to operate, the clip (15) must always lie flat on the clamping nut (1).

To secure the (tool-free) clamping nut (14):

 Do not use the clamping nut (tool-free) if the accessory has a clamping shank thicker than 6 mm! In this case, use the 2-hole nut (12) with 2-hole spanner (13).

- Lock the spindle (see chapter 7.1).
- Flip up the clip (15) on the clamping nut.
- Fit the clamping nut (14) on the spindle (3). See illustration on page 2.
- Tighten the clamping nut on the clip (15) **manually** in a clockwise direction.
- Flip down the clip (15) again .

Release the (tool-free) clamping nut (14):

- Lock the spindle (see chapter 7.1).
- Flip up the clip (15) on the clamping nut.
- Unscrew the clamping nut (14), turning it anticlockwise **manually** .

Note: If the clamping nut is very tightly secured (14), you can also use a two-hole spanner to unscrew it.

8. Use

8.1 Setting the speed (WEV 850-125)

Set the recommended speed using the thumbwheel (7). (Lower number = lower speed; higher number = higher speed)

Cutting disc, roughing disc, cup wheel and diamond cutting disc: **high speed**

Brush: **medium speed**

Sanding plate: **low to medium speed**

Note: We recommend using our angle polisher for polishing work.

8.2 Switching on and off

 Always guide the machine with both hands.

 Switch on first, then guide the accessory towards the workpiece.

 The machine must not be allowed to draw in additional dust and shavings. When switching the machine on and off and keep it away from dust deposits. After switching off the machine, only set it down when the motor has come to a standstill.

 Avoid inadvertent starts: always switch the tool off when the plug is removed from the mains socket or if there has been a power cut.

 In continuous operation, the machine continues running if it is forced out of your hands. Therefore, always hold the machine with both hands using the handles provided, stand securely and concentrate.

Machines with a slide switch:

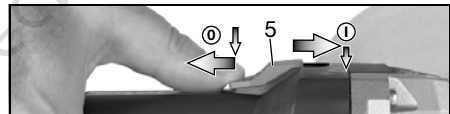

Switching on: push the slide switch (5) forwards. For continuous operation, tilt it downwards until it engages.

Switching off: press the rear end of the slide switch (5) and release it.

Machine with paddle switch (with deadman function):

(Machines with the designation WP...)

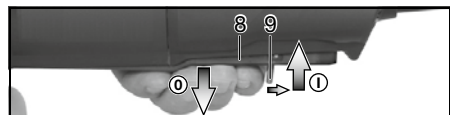

Switching on: Slide the switch-on lock (9) in the direction of the arrow and press the trigger (8).

Switching off: Release the trigger switch (8).

8.3 Working Directions

Grinding and sanding operations:

Press down the machine evenly on the surface and move it back and forth so that the surface of the workpiece does not become too hot.

Rough grinding: position the machine at an angle of 30° - 40° for the best working results.

Cut-off grinding:

 Always work against the run of the disc (see illustration). Otherwise the machine may kick back from the cut in an out of control manner. Guide the machine evenly at a speed suitable for the material being processed. Do not tilt, apply excessive force or sway from side to side.

Wire brushing:

Press down the machine evenly.

9. Cleaning

Particles may become deposited inside the power tool during operation. This impairs the cooling of the power tool. Conductive build-up can impair the protective insulation of the power tool and create an electrical hazard.

The power tool should be cleaned regularly, often and thoroughly through all front and rear air vents using a vacuum cleaner or by blowing in dry air. Before doing so, separate the power tool from the power source and wear protective goggles and a dust mask. Ensure appropriate suction is available when blowing out vents.

10. Troubleshooting (equipment-specific)

 **The machine does not start.** Restart protection is active. If the mains plug is inserted with the machine switched on or if the power supply is restored following an interruption, the machine does not start up. Switch the machine off and back on again.

WEV 850-125, WEQ 1400-125 only:

 **The speed drops while the machine is under load.** There is too much load on the machine! Allow the machine to run at idle speed until it has cooled down.

11. Accessories

Use only genuine Metabo accessories. See page 4.

Only use accessories which fulfil the requirements and specifications listed in these operating instructions.

A Cutting guard clip / guard for cut-off grinding

Designed for work with cutting disc and diamond cutting discs. Once the cutting guard clip is fitted, the safety guard becomes a cutting guard.

B Extraction guard for cut-off grinding

Designed for cutting through stone slabs with diamond cutting discs. With nozzle for extracting stone dust using a suitable extraction unit.

C Hand protection

Intended for work with backing pads, sanding plates, wire brushes and support plates, sanding pads, wire brushes and diamond drill bits for tiles.

Install the hand guard under the additional side-mounted handle.

D Two hole nut (12)

E M-Quick clamping nut (1)

F Clamping nut (tool-free) (14)

For a complete range of accessories, see www.metabo.com or the accessories catalogue.

12. Repairs

 Repairs to electrical tools must ONLY be carried out by qualified electricians!

Contact your local Metabo representative if you have Metabo power tools requiring repairs. See www.metabo.com for addresses.

You can download a list of spare parts from www.metabo.com.

13. Environmental Protection

The sanding dust generated may contain hazardous materials: do not dispose of dust with household waste, but at a special collection point for hazardous waste.

Observe national regulations on environmentally compatible disposal and on the recycling of disused machines, packaging and accessories.

 Only for EU countries: never dispose of power tools in your household waste! According to European Directive 2012/19/EU on Waste from Electric and Electronic Equipment and implementation in national law, used power tools must be collected separately and recycled in an environmentally-friendly manner.

14. Technical Specifications

Explanatory notes on the specifications on page 3. Subject to change in accordance with technical progress.

- ∅ = max. diameter of the accessory
- $t_{\max,1}$ = max. permitted thickness of the clamping shank on accessory when using two-hole nut (12)
- $t_{\max,2}$ = max. permitted thickness of clamping shank on accessory when using "M-Quick" clamping nut (1)
- $t_{\max,3}$ = max. permitted thickness of clamping shank on accessory when using (tool-free) clamping nut (14)
- $t_{\max,4}$ = roughing disc/cutting disc:
max. permitted thickness of accessory
- M = Spindle thread
- l = Length of the sanding spindle
- n^* = No-load speed (maximum speed)
- n_v^* = No-load speed (adjustable)

P_1 = Rated input power
 P_2 = Power output
 m = Weight without mains cable

Measured values determined in conformity with EN 60745.

- Machine in protection class II
- ~ AC power

The technical specifications quoted are subject to tolerances (in compliance with relevant valid standards).

Emission values

These values make it possible to assess the emissions from the power tool and to compare different power tools. The actual load may be higher or lower depending on operating conditions, the condition of the power tool or the accessories used. Please allow for breaks and periods when the load is lower for assessment purposes. Arrange protective measures for the user, such as organisational measures based on the adjusted estimates.

Total vibration value (vector sum of three directions) determined in accordance with EN 60745:

$a_{h, SG}$ = Vibration emission value (surface grinding)
 $a_{h, DS}$ = Vibration emission value (sanding with sanding plate)
 $K_{h, SG/DS}$ = Uncertainty (vibration)

Typical A-effective perceived sound levels:

L_{pa} = Sound-pressure level
 L_{WA} = Acoustic power level
 K_{pA}, K_{WA} = Uncertainty

 **Wear ear protectors!**

