

metabo®

PROFESSIONAL POWER TOOL SOLUTIONS

W 2000-180

W 2000-230

W 2200-180

W 2200-230

WE 2000-230

WE 2200-230

WP 2000-230

WP 2200-180

WP 2200-230

WEP 2200-230



de Originalbetriebsanleitung 5

en Original instructions 12

fr Notice originale 18

nl Oorspronkelijke gebruiksaanwijzing 25

it Istruzioni originali 32

es Manual original 39

pt Manual original 46

sv Bruksanvisning i original 53

fi Alkuperäiset ohjeet 59

no Original bruksanvisning 66

da Original brugsanvisning 72



pl Instrukcja oryginalna 79

el Πρωτότυπες οδηγίες χρήσης 87

hu Eredeti használati utasítás 95

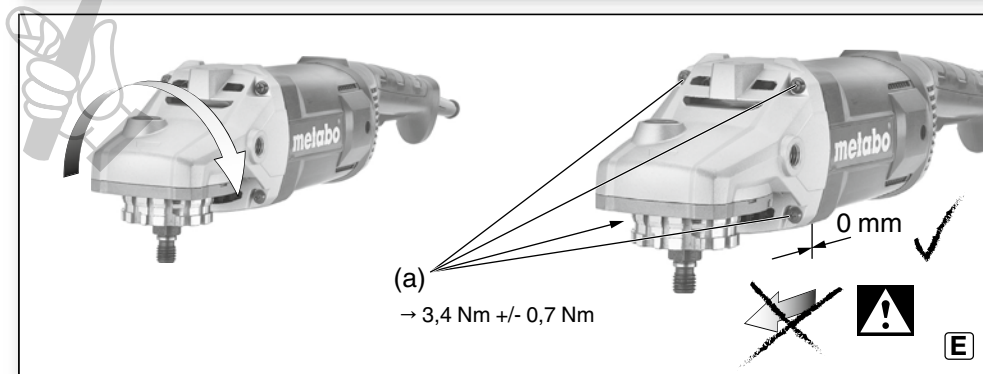
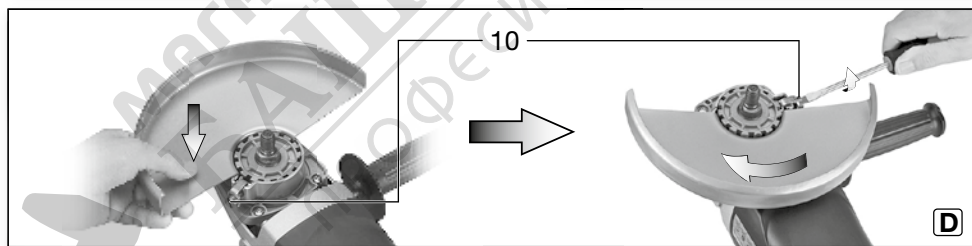
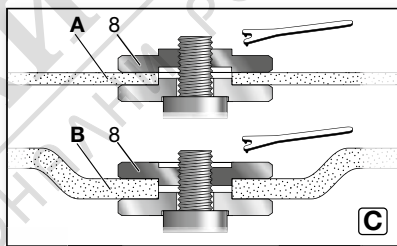
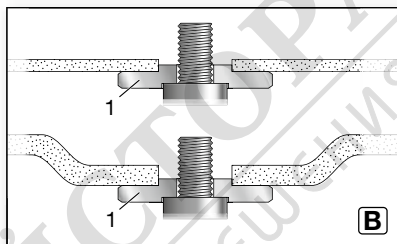
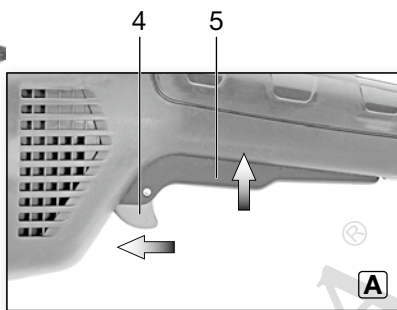
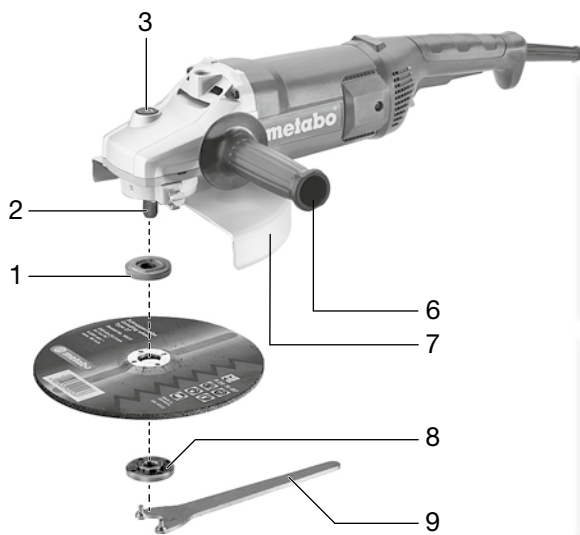
ru Оригинальное руководство по эксплуатации 102



		W 2000-180 *1) Serial Number: 06429..		W 2000-230 *1) Serial Number: 06430..		W 2200-180 *1) Serial Number: 06434..		WP 2200-180 *1) Serial Number: 06438..		W 2200-230 *1) Serial Number: 06435..		WE 2000-230 *1) Serial Number: 06432..		WE 2200-230 *1) Serial Number: 06437..		WP 2000-230 *1) Serial Number: 06431..		WP 2200-230 *1) Serial Number: 06436..		WEP 2200-230 *1) Serial Number: 06428..	
		Ø	mm (in)	180 (7)		230 (9)		180 (7)						230 (9)							
t_{max1}; t_{max2}; t_{max3}		mm (in)		12; 8; 8 (15/32; 5/16, 5/16)																	
 M / l		- / mm (in)		M 14 / 24 (15/16)																	
n		min ⁻¹ (rpm)		8450		6600		8450						6600							
P₁		W		2000				2200				2000		2200		2000				2200	
P₂		W		1370				1520				1370		1520		1370				1520	
m		kg (lbs)		5,0 (11.0)		5,2 (11.5)		5,0 (11.0)						5,2 (11.5)							
a_{h,SG}/K_{h,SG}		m/s ²		6,5 / 1,5																	
a_{h,DS}/K_{h,DS}		m/s ²		< 2,5 / 1,5																	
L_{pA}/K_{pA}		dB(A)		89 / 3		90 / 3		89 / 3						90 / 3							
L_{WA}/K_{WA}		dB(A)		100 / 3		101 / 3		100 / 3						101 / 3							

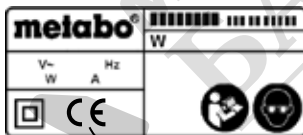

*2) 2006/42/EC, 2014/30/EU, 2011/65/EU
 *3) EN 60745-1:2009+A11:2010, EN 60745-2-3:2011+A2:2013+A11:2014+A12:2014+A13:2015, EN 50581:2012

2019-03-18, Bernd Fleischmann *ppa. B.F.*
 Direktor Innovation, Forschung und Entwicklung
 (Director Innovation, Research and Development)

*4) Metabowerke GmbH, Metabo-Allee 1,
 72622 Nuertingen, Germany

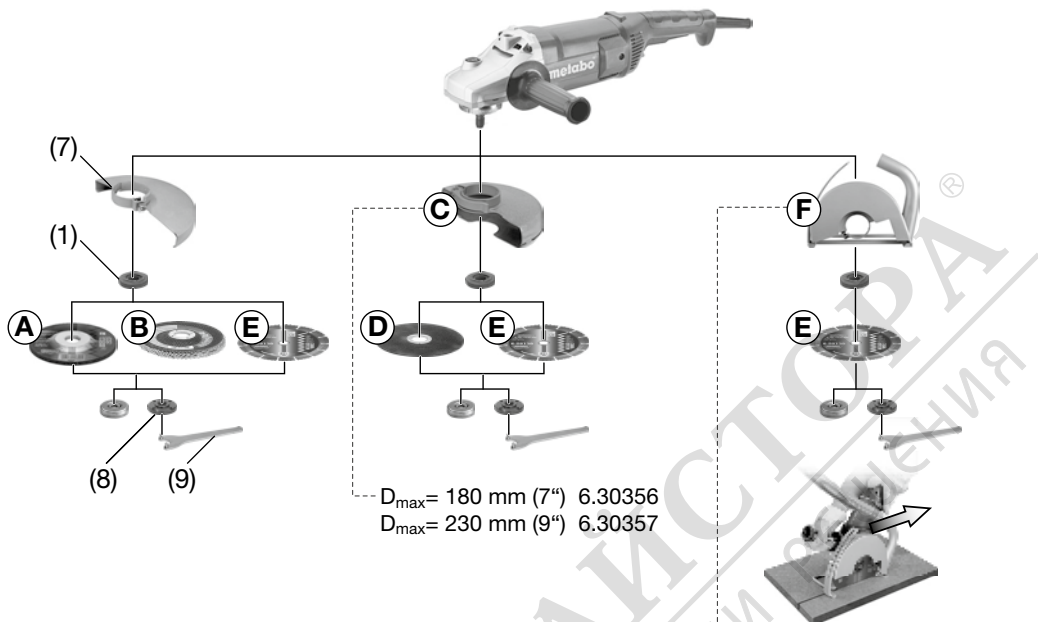

$D_{max} = 180 \text{ mm (7") } 6.31166$
 $D_{max} = 230 \text{ mm (9") } 6.31167$

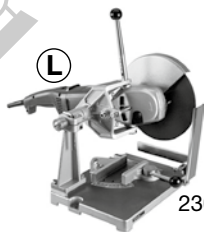
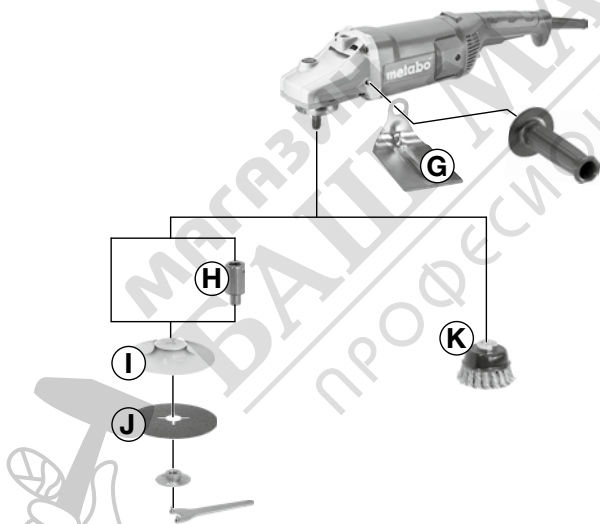

230 mm (9") 6.35000

(M) (M 14) 6.30706

(N) (M 14) 6.30800



Original instructions

1. Conformity Declaration

We declare in our sole responsibility: These angle grinders, identified by type and serial number *1), comply with all relevant requirements of the directives *2) and standards *3). Technical file at *4) - see page 3.

2. Specified Use

Machines fitted with original Metabo accessories are suitable for grinding, sanding, separating and wire brushing metal, concrete, stone and similar materials without the use of water.

The user bears sole responsibility for any damage caused by improper use.

Generally accepted accident prevention regulations and the enclosed safety information must be observed.

3. General Safety Instructions



For your own protection and for the protection of your power tool, pay attention to all parts of the text that are marked with this symbol!



WARNING – Reading the operating instructions will reduce the risk of injury.



WARNING Read all safety warnings and instructions. *Failure to follow all safety warnings and instructions may result in electric shock, fire and/or serious injury.*

Keep all safety instructions and information for future reference.

Pass on your power tool only together with these documents.

4. Special Safety Instructions

4.1 Safety Warnings Common for Grinding, Sanding, Wire Brushing or Abrasive Cutting-Off Operations:

Use

a) **This power tool is intended to function as a grinder, sander, wire brush or cut-off tool. Read all safety warnings, instructions, illustrations and specifications provided with this power tool.** Failure to follow all instructions listed below may result in electric shock, fire and/or serious injury.

b) **Operations such as polishing are not recommended to be performed with this power tool.** Operations for which the power tool was not designed may create a hazard and cause personal injury.

c) **Do not use accessories which are not specifically designed and recommended by the tool manufacturer.** Just because the accessory

can be attached to your power tool, it does not assure safe operation.

d) **The rated speed of the accessory must be at least equal to the maximum speed marked on the power tool.** Accessories running faster than their rated speed can break and fly apart.

e) **The outside diameter and the thickness of your accessory must be within the capacity rating of your power tool.** Incorrectly sized accessories cannot be adequately guarded or controlled.

f) **Treaded mounting of accessories must match the grinder spindle thread. For accessories mounted by flanges, the arbour hole of the accessory must fit the locating diameter of the flange.** Accessories that do not match the mounting hardware of the power tool will run out of balance, vibrate excessively and may cause loss of control.

g) **Do not use a damaged accessory. Before each use inspect the accessory such as abrasive wheels for chips and cracks, backing pad for cracks, tear or excess wear, wire brush for loose or cracked wires. If a power tool or accessory is dropped, inspect for damage or install an undamaged accessory. After inspecting and installing an accessory, position yourself and bystanders away from the plane of the rotating accessory and run the power tool at maximum no-load speed for one minute.** Damaged accessories will normally break apart during this test time.

h) **Wear personal protective equipment. Depending on application, use face shield, safety goggles or safety glasses. As appropriate, wear dust mask, hearing protectors, gloves and workshop apron capable of stopping small abrasive or workpiece fragments.** The eye protection must be capable of stopping flying debris generated by various operations. The dust mask or respirator must be capable of filtering particles generated by your operation. Prolonged exposure to high intensity noise may cause hearing loss.

i) **Keep bystanders a safe distance away from work area. Anyone entering the work area must wear personal protective equipment.** Fragments of workpiece or of a broken accessory may fly away and cause injury beyond immediate area of operation.

j) **Hold power tool by insulated gripping surfaces only, when performing an operation where the cutting accessory may contact hidden wiring or its own cord.** A cutting accessory contacting a "live" wire may make exposed metal parts of the power tool "live" and give the operator an electric shock.

k) **Position the cord clear of the spinning accessory.** If you lose control, the cord may be cut or snagged and your hand or arm may be pulled into the spinning accessory.

- l) **Never lay the power tool down until the accessory has come to a complete stop.** The spinning accessory may grab the surface and pull the power tool out of your control.
- m) **Do not run the power tool while carrying it at your side.** Accidental contact with the spinning accessory could snag your clothing, pulling the accessory into your body.
- n) **Regularly clean the power tool's air vents.** The motor's fan will draw the dust inside the housing and excessive accumulation of powdered metal may cause electrical hazards.
- o) **Do not operate the power tool near flammable materials.** Sparks could ignite these materials.
- p) **Do not use accessories that require liquid coolants.** Using water or other liquid coolants may result in electrocution or shock.

4.2 Kickback and Related Warnings

Kickback is a sudden reaction to a pinched or snagged rotating wheel, backing pad, brush or any other accessory. Pinching or snagging causes rapid stalling of the rotating accessory which in turn causes the uncontrolled power tool to be forced in the direction opposite of the accessory's rotation at the point of the binding.

For example, if an abrasive wheel is snagged or pinched by the workpiece, the edge of the wheel that is entering into the pinch point can dig into the surface of the material causing the wheel to climb out or kick out. The wheel may either jump toward or away from the operator, depending on direction of the wheel's movement at the point of pinching. Abrasive wheels may also break under these conditions.

Kickback is the result of power tool misuse and/or incorrect operating procedures or conditions and can be avoided by taking proper precautions as given below.

- a) **Maintain a firm grip on the power tool and position your body and arm to allow you to resist kickback forces. Always use the auxiliary handle, if provided, for maximum control over kickback or torque reaction during start-up.** The operator can control torque reactions or kickback forces, if proper precautions are taken.
- b) **Never place your hand near the rotating accessory.** Accessory may kickback over your hand.
- c) **Do not position your body in the area where power tool will move if kickback occurs.** Kickback will propel the tool in direction opposite to the wheel's movement at the point of snagging.
- d) **Use special care when working corners, sharp edges etc. Avoid bouncing and snagging the accessory.** Corners, sharp edges or bouncing have a tendency to snag the rotating accessory and cause loss of control or kickback.
- e) **Do not attach a saw chain woodcarving blade or toothed saw blade.** Such blades create frequent kickback and loss of control.

4.3 Safety Warnings Specific for Grinding and Cutting-Off Operations:

- a) **Use only wheel types that are recommended for your power tool and the specific guard designed for the selected wheel.** Wheels for which the power tool was not designed cannot be adequately guarded and are unsafe.
- b) **The grinding surface of centre depressed wheels must be mounted below the plane of the guard lip.** An improperly mounted wheel that projects through the plane of the guard lip cannot be adequately protected.
- c) **The guard must be securely attached to the power tool and positioned for maximum safety, so the least amount of wheel is exposed towards the operator.** The guard helps to protect the operator from broken fragments, accidental contact with the wheel and sparks that could ignite clothing.
- d) **Wheels must be used only for recommended applications.**
For example: do not grind with the side of cut-off wheel. Abrasive cut-off wheels are intended for peripheral grinding, side forces applied to these wheels may cause them to shatter.
- e) **Always use undamaged wheel flanges that are of correct size and shape for your selected wheel.** Proper wheel flanges support the wheel thus reducing the possibility of wheel breakage. Flanges for cut-off wheels may be different from grinding wheel flanges.
- f) **Do not use worn down wheels from larger power tools.** Wheels intended for larger power tools are not suitable for the higher speed of a smaller tool and may burst.

4.4 Additional Safety Warnings Specific for Abrasive Cutting-Off Operations:

- a) **Do not "jam" the cut-off wheel or apply excessive pressure. Do not attempt to make an excessive depth of cut.** Overstressing the wheel increases the loading and susceptibility to twisting or binding of the wheel in the cut and the possibility of kickback or wheel breakage.
- b) **Do not position your body in line with and behind the rotating wheel.** When the wheel, at the point of operation, is moving away from your body, the possible kickback may propel the spinning wheel and the power tool directly at you.
- c) **When wheel is binding or when interrupting a cut for any reason, switch off the power tool and hold the power tool motionless until the wheel comes to a complete stop. Never attempt to remove the cut-off wheel from the cut while the wheel is in motion otherwise kickback may occur.** Investigate and take corrective action to eliminate the cause of wheel binding.
- d) **Do not restart the cutting operation in the workpiece. Let the wheel reach full speed and carefully reenter the cut.** The wheel may bind, walk up or kickback if the power tool is restarted in the workpiece.
- e) **Support panels or any oversized workpiece to minimize the risk of wheel pinching and**

kickback. Large workpieces tend to sag under their own weight. Supports must be placed under the workpiece near the line of cut and near the edge of the workpiece on both sides of the wheel.

f) **Use extra caution when making a "pocket cut" into existing walls or other blind areas.** The protruding wheel may cut gas or water pipes, electrical wiring or objects that can cause kickback.

4.5 Safety Warnings Specific for Sanding Operations:

a) **Do not use excessively oversized sanding disc paper. Follow manufacturer's recommendations when selecting sanding paper.** Larger sanding paper extending beyond the sanding pad presents a laceration hazard and may cause snagging, tearing of the disc or kickback.

4.6 Safety Warnings Specific for Wire Brushing Operations:

a) **Be aware that wire bristles are thrown by the brush even during ordinary operation. Do not overstress the wires by applying excessive load to the brush.** The wire bristles can easily penetrate light clothing and/or skin.

b) **If the use of a guard is recommended for wire brushing, do not allow any interference of the wire wheel or brush with the guard.** Wire wheel or brush may expand in diameter due to work load and centrifugal forces.

4.7 Additional Safety Instructions:



WARNING – Always wear protective goggles.

Do not switch on the machine if tool parts or guard devices are missing or defective.

Machines with a soft start (indicated by an "WE..." in the model designation): An electronic error occurs if the machine accelerates to maximum speed very quickly when switched on. Other safety-related electronic functions are no longer available. Have the machine repaired immediately (see 12.).

Use elastic cushioning layers if they have been supplied with the grinding media and if required.

Observe the specifications of the tool or accessory manufacturer! Protect the discs from grease or impacts!

Grinding discs must be stored and handled with care in accordance with the manufacturer's instructions.

Never use cutting discs for roughing work! Do not apply pressure to the side of the cutting discs.

The workpiece must lay flat and be secured against slipping, e.g. using clamps. Large workpieces must be sufficiently supported.

If accessories with threaded inserts are used, the end of the spindle may not touch the base of the hole on the grinding tool. Make sure that the thread in the accessory is long enough to accommodate the full length of the spindle. The thread in the accessory must match the thread on the spindle.

Specifications for more information on the spindle length and thread.

Use of a fixed extractor system is recommended. Always install an RCD with a max. trip current of 30 mA upstream. If the angle grinder is shut down via the RCD, it must be checked and cleaned. See chapter 9. Cleaning.

Damaged, eccentric or vibrating tools must not be used.

Avoid damage to gas or water pipes, electrical cables and load-bearing walls (static).

Pull the plug out of the socket before making any adjustments, converting or servicing the machine.

A damaged or cracked additional handle must be replaced. Never operate a machine with a defective additional handle.

A damaged or cracked safety guard must be replaced. Never operate a machine with a defective safety guard.

Secure small workpieces. For example, clamp in a vice.

Reduce dust exposure:



Particles generated when working with this machine may contain substances that can cause cancer, allergic reactions, respiratory diseases, birth defects or other propagation defects. Some of these substances include: Lead (in paint containing lead), mineral dust (from bricks, concrete etc.), additives used for wood treatment (chromate, wood preservatives), some wood types (such as oak or beech dust), metals, asbestos.

The risk depends on for how long the user or nearby persons are exposed to the substance.

This dust must not be allowed to enter your body.

Do the following to reduce exposure to these substances: Ensure good ventilation of the workplace and wear appropriate protective equipment, such as respirators able to filter microscopically small particles.

Observe the relevant guidelines for your material, staff, application and place of application (e.g. occupational health and safety regulations, disposal).

Collect the generated particles at the source, avoid deposits in the surrounding area.

Use suitable accessories for special work (see chapter 11.), thus less particles enter the environment in an uncontrolled manner.

Use a suitable extraction unit.

Reduce dust exposure with the following measures:

- Do not direct the escaping particles and the exhaust air stream at yourself or nearby persons or on dust deposits.
- Use an extraction unit and/or air purifiers
- Ensure good ventilation of the workplace and keep clean using a vacuum cleaner Sweeping or blowing stirs up dust.
- Vacuum or wash the protective clothing Do not blow, beat or brush.

5. Overview

See page 2.

- 1 Support flange
- 2 Spindle
- 3 Spindle locking button
- 4 Lock (to prevent the machine from being switched on unintentionally, or for continuous operation)*
- 5 Trigger (for switching on and off)
- 6 Additional handle
- 7 Safety guard
- 8 Clamping nut
- 9 2-hole spanner
- 10 Screw (for adjusting and securing the safety guard)

* depending on equipment/not in scope of delivery

6. Commissioning

 Before plugging in, check to see that the rated mains voltage and mains frequency, as specified on the rating label, match your power supply.

 Always install an RCD with a max. trip current of 30 mA upstream.

Always use an extension cable with a minimum diameter of 1.5 mm². The extension cable must be suitable for the machine power rating (see Technical Specifications). If using a roll of cable, always roll up the cable completely.

6.1 Attaching the additional handle

 Always work with the additional handle attached (6)! Manually screw in the additional handle securely in the left, centre or right threaded hole (depending on requirements).

6.2 Attaching the safety guard (for work involving grinding wheels)

 Prior to commissioning: Fit the protective cover.

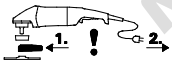

 For reasons of safety, the safety guard (7) should always be attached when roughing work is performed.

 For reasons of safety, the special parting guard should always be attached before parting work is performed (see chapter 11. Accessories).

See illustration D on page 2.

- Slacken the screw (10). Place the safety guard (7) in the position indicated.
- Turn the safety guard until the closed section is facing the operator.
- Tighten the screw (10), ensuring that the anti-twist device engages in the slots.
- Make sure that the guard is seated securely: you should not be able to turn the safety guard.

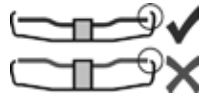

Use only accessories that are covered by at least 3.4 mm by the safety guard.

6.3 Power supply

The mains sockets must be protected using time-delay fuses or circuit breakers.

Machines with "WE..." in the model designation: (with integrated, automatic restriction of the starting current (soft start)). The mains sockets can also be protected using fast-acting fuses or circuit breakers.

7. Attaching the grinding wheel

 Disconnect the mains plug before changing any accessories. The machine must be switched off and the spindle at a standstill.

 For reasons of safety, attach the parting guard before performing parting work (see chapter 11. Accessories).

7.1 Locking the spindle

 Press in the spindle locking button (3) only when the spindle is stationary!

- Press in the spindle locking button (3) and turn the spindle (2) by hand until you feel the spindle locking button engage.

7.2 Placing the grinding wheel in position

See illustration B on page 2.

- Fit the support flange (1) on the spindle. The flange should not turn on the spindle when properly attached.
- Position the grinding wheel on the support flange (1) as shown in illustration B. The grinding wheel must lay flat on the supporting flange. The metal flange on the parting grinder disc must lay flat on the support flange.

7.3 Securing/Releasing the clamping nut

 **Securing the clamping nut (8):**

The 2 sides of the clamping nut are different. Screw the clamping nut onto the spindle as follows:

See illustration C on page 2.

- A) For thin grinding wheels:

The edge of the clamping nut (8) faces upwards so that the thin grinding wheel can be attached securely.

B) For thick grinding wheels:

The edge of the clamping nut (8) faces downwards so that the clamping nut can be attached securely to the spindle.

- Lock the spindle. Turn the clamping nut (8) clockwise using the 2-hole spanner (9) to secure.

Releasing the clamping nut:

- Lock the spindle (see chapter 7.1). Turn the clamping nut (8) anticlockwise using the 2-hole spanner (9) to unscrew.

8. Use

8.1 Switching On and Off

 Always guide the machine with both hands.

 Switch on first, then guide the accessory towards the workpiece.

 The machine must not be allowed to draw in additional dust and shavings. When switching the machine on and off, keep it away from dust deposits. After switching off the machine, only place it down when the motor has come to a standstill.

 Avoid inadvertent starts: always switch the tool off when the plug is removed from the mains socket or if there has been a power cut.

 In continuous operation, the machine continues running if it is forced out of your hands. Therefore, always hold the machine with both hands at the intended handles, take a secure stance and concentrate on the work.

See illustration A on page 2.

Torque activation

Switching on: Slide the lock (4) in the direction of the arrow and press the trigger (5).

Switching off: Release the trigger (5).

Continuous operation (depending on features)

Switching on: Slide the lock (4) in the direction of the arrow, press the trigger (5) and keep it pressed. The machine is now switched on. Now slide the lock (4) in the direction of the arrow once more to lock the trigger (5) (continuous operation).

Switching off: Press the trigger (5) and release.

8.2 Working instructions

Grinding:

Press down the machine evenly on the surface and move back and forth so that the surface of the workpiece does not become too hot.

Roughing: position the machine at an angle of 30° - 40° for the best working results.

Separating:

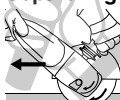
 Always work against the run of the disc (see illustration). Otherwise there is the danger of the machine kicking back from the cut out of control. Guide the machine evenly at a speed suitable for the material being processed. Do not tilt, apply excessive force or sway from side to side.

Sanding:

Press down the machine evenly on the surface and move back and forth so that the surface of the workpiece does not become too hot.

Wire brushing:

Press down the machine evenly.

8.3 Rotate gear housing

See illustration E on page 2.

- Disconnect from the power supply.
- Unscrew the 4 gear housing screws (a).
- **CAUTION! Do not remove the gear housing!**
- Turn the gear housing to the desired position without removing it.
- Screw in the 4 gear housing screws (a) in the available threads! Tightening torque = 3.4 Nm +/- 0.7 Nm.

9. Cleaning

It is possible that particles deposit inside the power tool during operation. This impairs the cooling of the power tool. Conductive build-up can impair the protective insulation of the power tool and cause electrical hazards.

The power tool should be cleaned regularly, often and thoroughly through all front and rear air vents using a vacuum cleaner or by blowing in dry air. Prior to this operation, separate the power tool from the power source and wear protective glasses and dust mask.

10. Troubleshooting

Machine with "WE..." in the model designation:

- **Restart protection: The machine does not start.** The restart protection is active. If the mains plug is inserted with the machine switched on, or if the current supply is restored following an interruption, the machine does not start up. Switch the machine off and on again.
- **When switched on, the machine accelerates to maximum speed very quickly,** i.e. automatic restriction of the starting current does not work (soft start). An electronic error exists. Other safety-related electronic functions are no longer available. Have the machine repaired immediately (see 12.).

W 2200.... W 2200.... WP 2000.... WP 2200....:

- Switching on procedures produce brief reductions in voltage. Unfavourable power conditions can be detrimental to other devices. Power impedances smaller than 0.2 ohm should not cause any malfunction.

11. Accessories

Use only genuine Metabo accessories.

Use only accessories that fulfil the requirements and specifications listed in these operating instructions.

Fit accessories securely. Secure the machine if it is operated in a bracket. Loss of control can cause personal injury.

See page 4.

- Roughing disc (always use with safety guard attached)
- Louwer disc (always use with safety guard attached)
- Parting safety guard.

- D Parting disc (always use with parting safety guard attached)
- E Diamond discs (always use with safety guard or parting safety guard attached)
- F Parting safety guard with guide slot (place on machine and secure with screws.) (with adapter for connection to a suitable dust extractor for extraction of stone dust generated when cutting stone slabs.)
- G Hand guard (for attaching under the additional side-mounted handle.)
- H Extension piece (for working with supporting discs. Increases the distance between the spindle and the supporting disc by approx. 35 mm)
- I Supporting disc for fibre discs (always attach using the supporting disc clamping nut supplied.) (always use with the hand guard attached.)
- J Fibre discs (always use with the hand guard attached.)
- K Steel wire brushes (always use with the hand guard attached.)
- L Bench cut-off stand
- M Adjusting nut (8)
- N "Quick"clamping nut

For complete range of accessories, see www.metabo.com or refer to the main catalogue.

12. Repairs

 Repairs to electrical tools must be carried out by qualified electricians ONLY!

If the mains connection cable of this tool is damaged, in order to prevent endangering personnel and property it must be replaced by the manufacturer, or the Customer Service of the manufacturer, or a similarly qualified person.

Contact your local Metabo representative if you have Metabo power tools requiring repairs. For addresses see www.metabo.com.

You can download a list of spare parts from www.metabo.com.

13. Environmental Protection

The sanding dust generated may contain hazardous materials: do not dispose of with the household waste, but at a special collection point for hazardous waste.

Observe national regulations on environmentally compatible disposal and on the recycling of disused machines, packaging and accessories.

 Only for EU countries: Never dispose of power tools in your household waste! In accordance with European Guideline 2012/19/EU on used electronic and electric equipment and its implementation in national legal systems, used power tools must be collected separately and handed in for environmentally compatible recycling.

14. Technical Specifications

Explanation of details on page 3. Subject to changes serving technical progress.

- \emptyset = max. diameter of accessory
- $t_{\max,1}$ = max. permitted thickness of clamping shank on accessory when using clamping nut (8)
- $t_{\max,2}$ = max. permitted thickness of clamping shank on accessory when using "Quick"clamping nut
- $t_{\max,3}$ = Roughing disc/Parting disc: max. permitted thickness of accessory
- M = Spindle thread
- l = Length of the grinding spindle
- n = No-load speed (maximum speed)
- P_1 = Nominal power input
- P_2 = Power output
- m = Weight without mains cable

Measured values determined in conformity with EN 60745.

-  Machine in protection class II
- ~ Alternating current

The technical specifications quoted are subject to tolerances (in compliance with the relevant valid standards).

Emission values

These values make it possible to assess the emissions from the power tool and to compare different power tools. Depending on the operating conditions, the condition of the power tool or the accessories, the actual load may be higher or lower. For assessment purposes, please allow for breaks and periods when the load is lower. Based on the adjusted estimates, arrange protective measures for the user e.g. organisational measures.

Vibration total value (vector sum of three directions) determined in accordance with EN 60745:

$a_{h,SG}$ = Vibration emission value (sanding surfaces)

$a_{h,DS}$ = Vibration emission value (sanding with sanding pad)

$K_{h,SG/DS}$ = Uncertainty (vibration)

Typical A-effective perceived sound levels:

L_{pA} = Sound pressure level

L_{WA} = Acoustic power level

K_{pA}, K_{WA} = Uncertainty

 **Wear ear protectors!**