

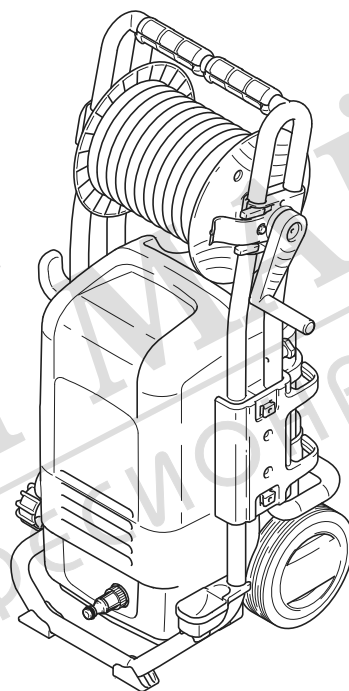

**Spare Parts List**  
**Ersatzteilliste**  
**Liste de pièces détachées**  
**Lista de piezas de repuesto**

2012-06



**HW151**

995700597 (D, GB, F, E)

HW151

1

Gehäuse  
Case  
Carter  
Cárter

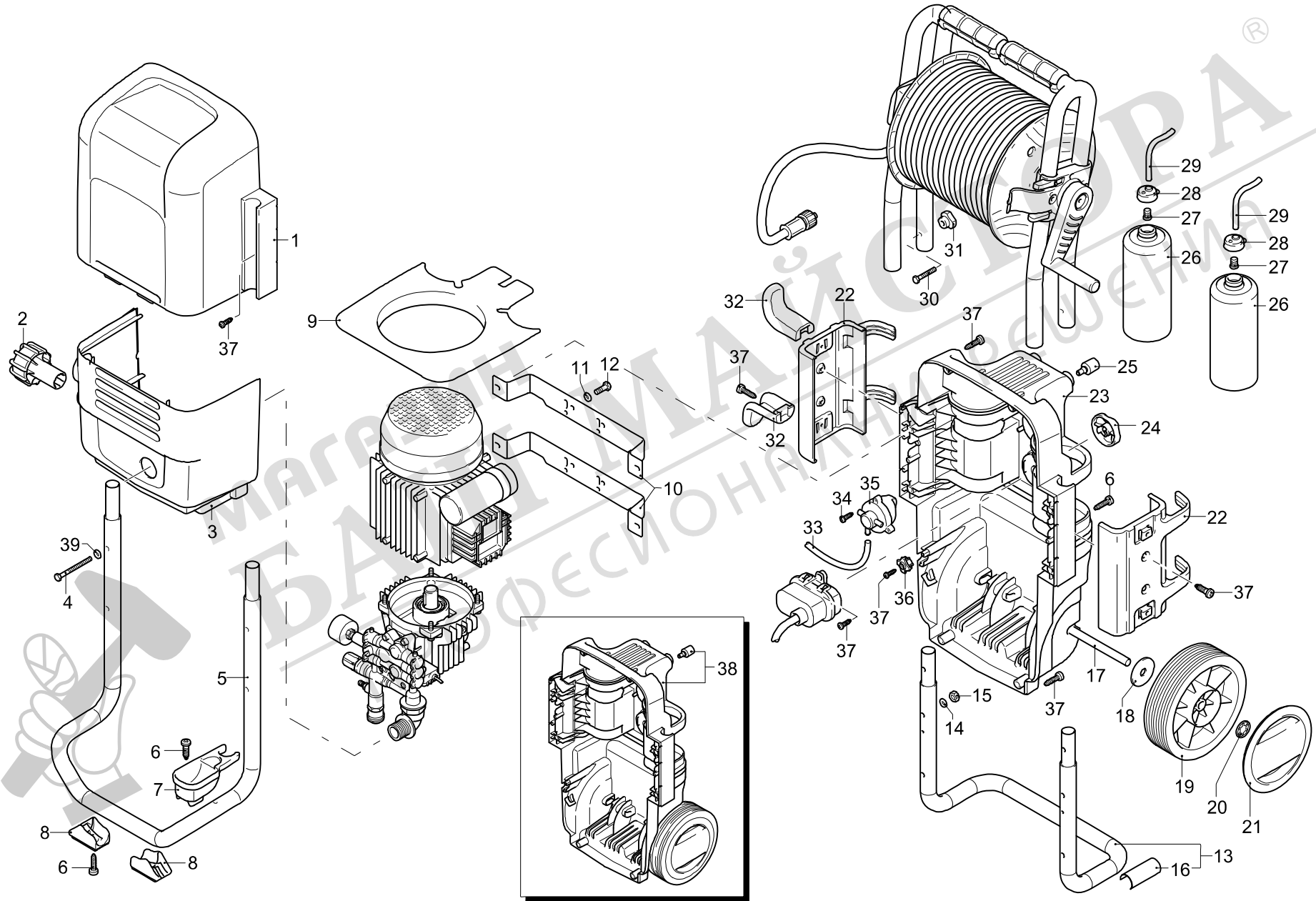

HW151

1

Gehäuse  
Case  
Carter  
Cárter

Seite / Page	Pos.	HW151	Teil-Nr. Part No. No. de pièce No. de pieza	Hinweise Notes Renseign. Nota	Bezeichnung	Spezifikation Specification	Description	Désignation	Denominación
1	1	1	609 580 020		HAUBE GRÜN	MAKITA	GREEN CASING	CAPOT VERT	CAPÓ VERDE
1	2	1	609 360 760		KNAUF		KNOB	MOLETTE	POMO
1	3	1	609 580 230		HAUBE GRÜN	MAKITA	GREEN CASING	CAPOT VERT	CAPÓ VERDE
1	4	4	609 320 570		SCHRAUBE		SCREW	VIS	TORNILLO
1	5	1	609 580 070		RAHMEN		FRAME	CADRE	BASTIDOR
1	6	5	609 060 200		SCHRAUBE		SCREW	VIS	TORNILLO
1	7	1	609 580 250		ZUBEHÖRTRÄGER		ACCESSORIES CARRIER	PORTE-ACCESSOIRES	PORTA-ACCESORIOS
1	8	2	609 580 270		HALTERUNG		SUPPORT	SUPPORT	SOPORTE
1	9	1	609 580 040		HALTERUNG		SUPPORT	SUPPORT	SOPORTE
1	10	2	609 580 260		HALTERUNG		SUPPORT	SUPPORT	SOPORTE
1	11	4	609 550 331		UNTERLEGSCHLEIBE		WASHER	RONDELLE	ARANDELA
1	12	4	609 320 350		SCHRAUBE	TE M 6x12	SCREW	VIS	TORNILLO
1	13	1	609 580 060		RAHMEN		FRAME	CADRE	BASTIDOR
1	14	4	609 480 650		UNTERLEGSCHLEIBE		WASHER	RONDELLE	ARANDELA
1	15	4	609 480 640		MUTTER		NUT	ÉCROU	TUERCA
1	16	2	609 580 370		SCHUTZ		GUARD	PROTECTION	PROTECCIÓN
1	17	1	609 180 080		RADACHSE		AXLE	ESSIEU	EJE
1	18	2	609 680 890		UNTERLEGSCHLEIBE	12,5x48x2,5 Z/B	WASHER	RONDELLE	ARANDELA
1	19	2	609 580 280		RAD	D175, D12 mm	WHEEL	ROUE	RUEDA
1	20	2	609 680 880		UNTERLEGSCHLEIBE		WASHER	RONDELLE	ARANDELA
1	21	2	609 580 170		RADKAPPE	MAKITA	WHEEL COVER	CHAPEAU DE MOYEU	CAPERUZA DE RUEDA
1	22	2	609 580 050		ZUBEHÖRTRÄGER		ACCESSORIES CARRIER	PORTE-ACCESSOIRES	PORTA-ACCESORIOS
1	23	1	609 580 010		GEHÄUSE		HOUSING	CARTER	CÁRTER
1	24	1	609 900 220		DREHKNOPF		KNOB	MANETTE	MANDO
1	25	2	609 180 330		GUMMIFUß		RUBBER FOOT	CAPSULE CAOUTCHOUC	GOMA
1	26	2	609 180 130		REINIGUNGSBEHÄLTER	0,75 L	TANK	RÉSERVOIR	DEPÓSITO
1	27	2	609 000 230		FILTER		FILTER	FILTRE	FILTRO
1	28	2	609 580 190		VERSCHLUSS		PLUG	BOUCHON	TAPÓN
1	29	2	609 580 300		REINIGUNGSMITTELSCHLAUCH	D6x9, 55 cm	DETERGENT HOSE	TUYAU NETTOYANT	TUBO DETERGENTE
1	30	2	609 050 037		SCHRAUBE		SCREW	VIS	TORNILLO
1	31	2	609 050 019		KNAUF		KNOB	MOLETTE	POMO
1	32	2	609 360 090		ZUBEHÖRTRÄGER		ACCESSORIES CARRIER	PORTE-ACCESSOIRES	PORTA-ACCESORIOS
1	33	1	609 580 290		REINIGUNGSMITTELSCHLAUCH	D6X9, 45 cm	DETERGENT HOSE	TUYAU NETTOYANT	TUBO DETERGENTE
1	34	3	609 000 110		SCHRAUBE		SCREW	VIS	TORNILLO
1	35	1	609 440 190		DETERGENTREGLER		DETERGENT REGULATOR	REGULATEUR DÉTERGENT	REGULADOR DETERGENTE
1	36	1	609 600 100		KABELVERSCHRAUBUNG		CABLE GLAND	SERRE-CÂBLE	PRENSACABLE
1	37	15	609 100 300		SCHRAUBE	5x16	SCREW	VIS	TORNILLO
1	38	1	609 589 000		GEHÄUSE KPL.		HOUSING COMPLETE	CARTÈRE CPL.	CÁRTER CPL.
1	39	4	609 680 960		UNTERLEGSCHLEIBE		WASHER	RONDELLE	ARANDELA

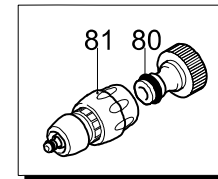
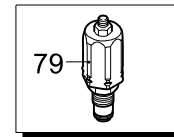
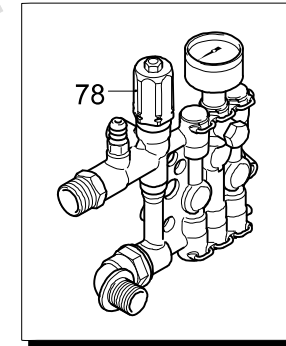
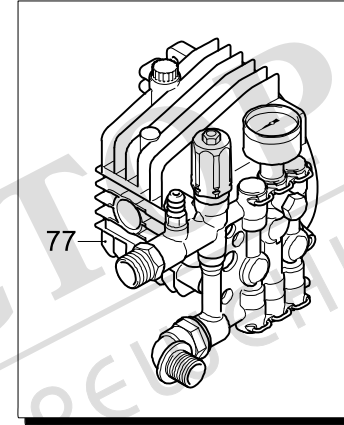
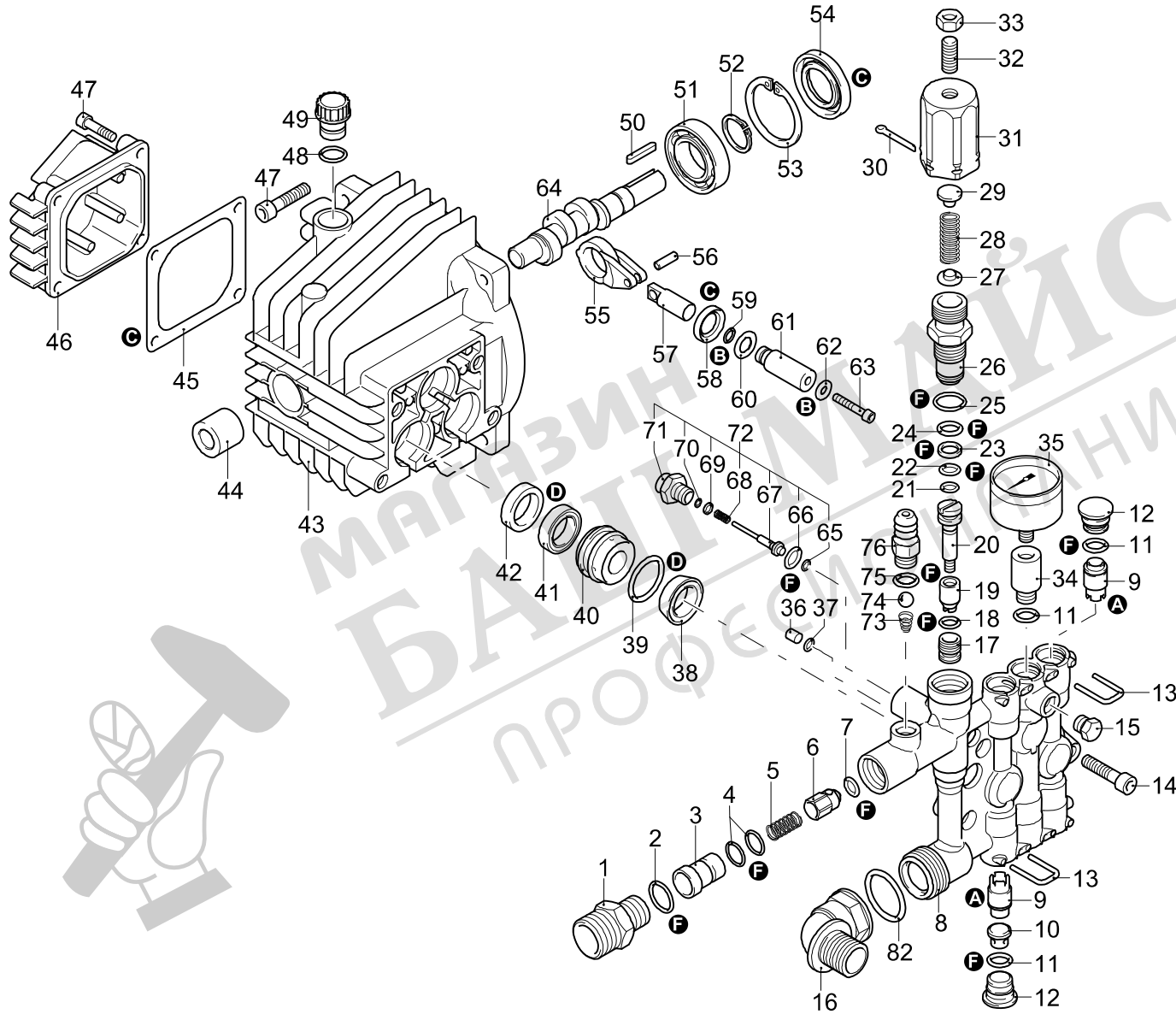

- A
- B
- C
- D
- E
- F
- G



МАГАЗИН  
БАЛТИЙСКИ  
ПРОФЕСИОНАЛНИ РЕЗЕРВНИ ДЕТАЛИ

Seite / Page	Pos.	Teil-Nr. Part No. No. de pièce No. de pieza	Hinweise Notes Renseign. Nota	Bezeichnung	Spezifikation Specification	Description	Désignation	Denominación
2	A	1 609 042 566		SATZ VENTILE		VALVE KIT	KIT VANNES	KIT VÁLVULAS
2	B	1 609 002 623		SATZ KOLBEN		PISTON KIT	KIT PISTONS	KIT PISTONES
2	C	1 609 001 876		SATZ ÖLDICHTUNGEN		OIL SEAL KIT	KIT JOINTS D'ÉTANCHÉITÉ HUILE	KIT RETENCIONES ACEITE
2	D	1 609 042 567		SATZ WASSERDICHTUNGEN		WATER SEAL KIT	KIT JOINTS D'ÉTANCHÉITÉ EAU	KIT RETENCIONES AGUA
2	F	1 609 042 568		SATZ DICHTUNGEN		GASKET KIT	KIT JOINTS	KIT GUARNICIONES
2	1	1 609 900 120		VERBINDUNGSSTÜCK	3/8", M22x1,5	FITTING	RACCORD	RACOR
2	2	1 609 740 290		O-RING	ø 14x1,78	O-RING	JOINT TORIQUE	GUARNICIÓN OR
2	3	1 609 901 060		INJEKTOR		INJECTOR	INJECTEUR	INYECTOR
2	4	2 609 800 560		O-RING	ø 8,73x1,78	O-RING	JOINT TORIQUE	GUARNICIÓN OR
2	5	1 609 080 091		FEDER		SPRING	RESSORT	RESORTE
2	6	1 609 901 070		VERSCHLUSS		SHUTTER	CLAPET	OBTURADOR
2	7	1 609 460 430		O-RING	ø 4x2,5	O-RING	JOINT TORIQUE	GUARNICIÓN OR
2	8	1 609 344 850		KOPF		HEAD	TÊTE	CABEZA
2	9	6 609 349 055		VENTIL		VALVE	VANNE	VÁLVULA
2	10	3 609 344 770		DISTANZSTÜCK		SPACER	ENTRETOISE	SEPARADOR
2	11	6 609 465 720		O-RING		O-RING	JOINT TORIQUE	GUARNICIÓN OR
2	12	5 609 344 800		VERSCHLUSS		PLUG	BOUCHON	TAPÓN
2	13	6 609 344 790		KLEMME		FORK	COLLIER	HORQUILLA
2	14	4 609 850 850		SCHRAUBE	M 6x30	SCREW	VIS	TORNILLO
2	15	1 609 620 301		VERSCHLUSS	1/8" G	PLUG	BOUCHON	TAPÓN
2	16	1 609 500 280		VERLÄNGERUNG		EXTENSION	RALLONGE	ALARGADOR
2	17	1 609 342 701		SITZ		SEAT	LOGEMENT	ALOJAMIENTO
2	18	1 609 600 180		O-RING	ø 7,66x1,78	O-RING	JOINT TORIQUE	GUARNICIÓN OR
2	19	1 609 460 151		KOLBEN		PISTON	PISTON	PISTÓN
2	20	1 609 021 900		KOLBEN		PISTON	PISTON	PISTÓN
2	21	1 609 080 190		O-RING	ø 2,90x1,78	O-RING	JOINT TORIQUE	GUARNICIÓN OR
2	22	1 609 600 180		O-RING	ø 7,66x1,78	O-RING	JOINT TORIQUE	GUARNICIÓN OR
2	23	1 609 080 401		RING		RING	BAGUE	ANILLO
2	24	1 609 820 510		O-RING	ø 10,82x1,78	O-RING	JOINT TORIQUE	GUARNICIÓN OR
2	25	1 609 740 290		O-RING	ø 14x1,78	O-RING	JOINT TORIQUE	GUARNICIÓN OR
2	26	1 609 344 870		KOLBENFÜHRUNG		PISTON GUIDE	GUIDE PISTON	GUÍA PISTÓN
2	27	1 609 343 450		TELLER		WOBBLE PLATE	PLATEAU	PLATILLO
2	28	1 609 460 190		FEDER		SPRING	RESSORT	RESORTE
2	29	1 609 980 220		TELLER		WOBBLE PLATE	PLATEAU	PLATILLO
2	30	1 609 500 550		SPLINTSTIFT	2,6x15 UNI 1336 Z/B	SPLIT PIN	GOUPILLE	CHAVETA
2	31	1 609 344 881		EINSATZ		INSERT	INSERT	INSERCIÓN
2	32	1 609 980 740		VERSCHLUSS		PLUG	BOUCHON	TAPÓN
2	33	1 609 060 120		MUTTER	M 6	NUT	ÉCROU	TUERCA
2	34	1 609 344 940		VERLÄNGERUNG		EXTENSION	RALLONGE	ALARGADOR
2	35	1 609 040 476		MANOMETER		PRESSURE GAUGE	MANOMÈTRE	MANÓMETRO
2	36	1 609 344 890		VERSCHLUSS		PLUG	BOUCHON	TAPÓN
2	37	1 609 560 870		O-RING		O-RING	JOINT TORIQUE	ANILLO DE GUARNICIÓN

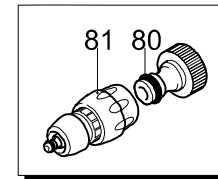
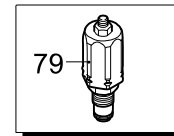
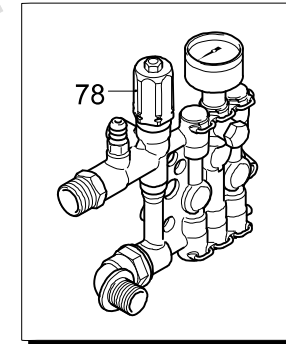
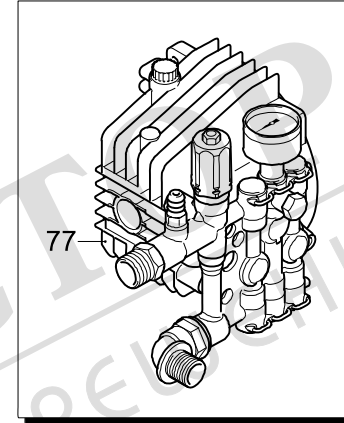
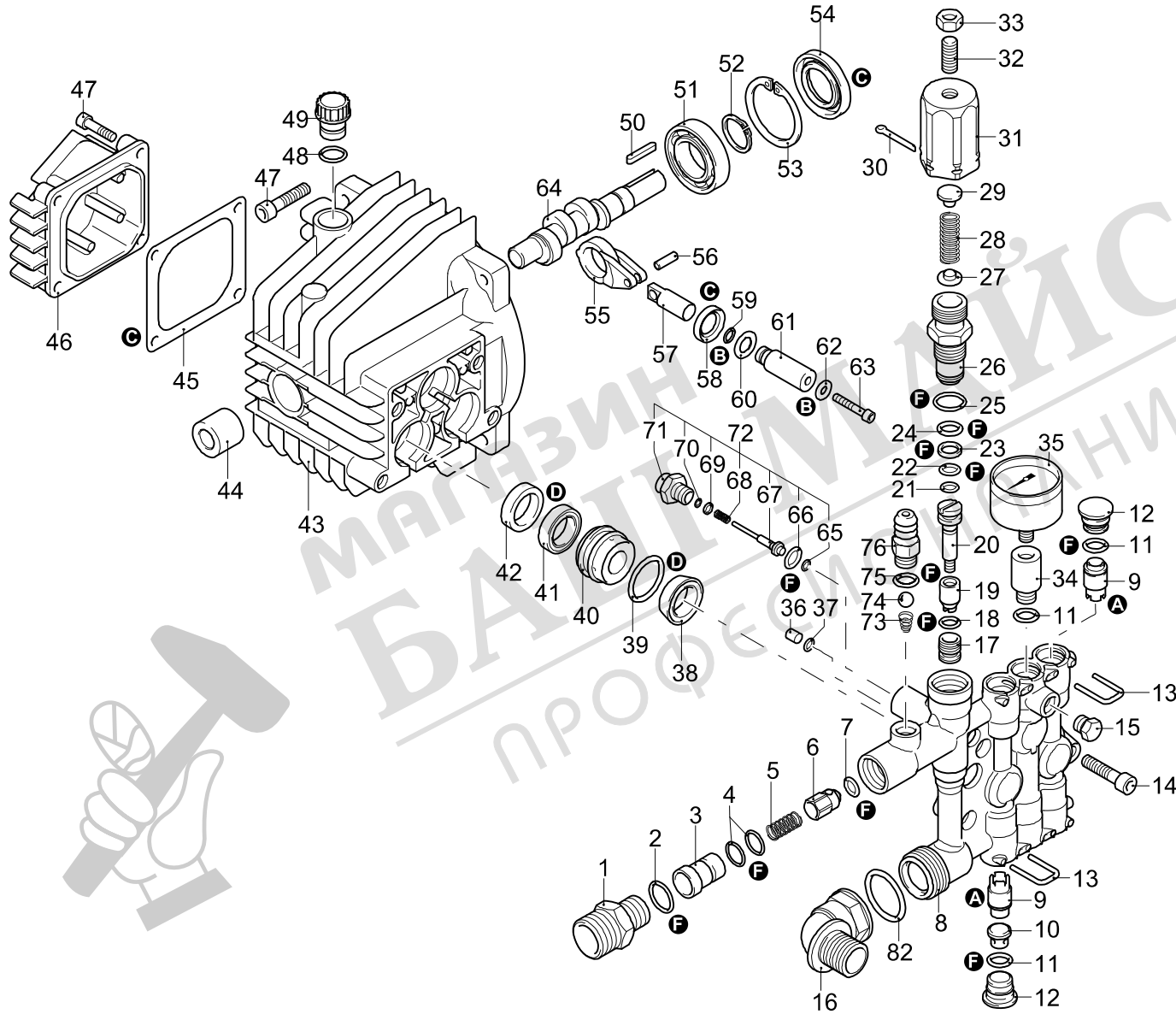

- A
- B
- C
- D
- E
- F
- G



МАГАЗИН  
БАЛТИЙСКИ  
ПРОФЕСИОНАЛНИ РЕЗЕРВНИ ДЕТАЛИ

Seite / Page	Pos.	Teil-Nr. Part No. No. de pièce No. de pieza	Hinweise Notes Renseign. Nota	Bezeichnung	Spezifikation Specification	Description	Désignation	Denominación
2	38	3 609 460 180		WASSERDICHTUNG		WATER SEAL	ÉTANCHÉITÉ EAU	RETENCIÓN AGUA
2	39	3 609 770 260		O-RING	ø 23,52x1,78	O-RING	JOINT TORIQUE	GUARNICIÓN OR
2	40	3 609 344 750		KOLBENFÜHRUNG		PISTON GUIDE	GUIDE PISTON	GUÍA PISTÓN
2	41	3 609 260 440		WASSERDICHTUNG	C1	WATER SEAL	ÉTANCHÉITÉ EAU	RETENCIÓN AGUA
2	42	3 609 344 760		ÖLDICHTUNG		OIL SEAL	ÉTANCHÉITÉ HUILE	RETENCIÓN ACEITE
2	43	1 609 344 050		PUMPENKÖRPER		PUMP BODY	CORPS POMPE	CUERPO BOMBA
2	44	1 609 260 050		BUCHSE		BUSHING	DOUILLE	CASQUILLO
2	45	1 609 040 710		O-RING	ø 56x2	O-RING	JOINT TORIQUE	GUARNICIÓN OR
2	46	1 609 344 060		DECKEL		COVER	COUVERCLE	TAPA
2	47	1 609 260 780		SCHRAUBE	TCEI M 5x25	SCREW	VIS	TORNILLO
2	48	1 609 880 840		O-RING	ø 9,25x1,78	O-RING	JOINT TORIQUE	GUARNICIÓN OR
2	49	1 609 343 900		VERSCHLUSS		PLUG	BOUCHON	TAPÓN
2	50	1 609 880 111		SPLINT		KEY	LANGUETTE	LENGÜETA
2	51	1 609 341 070		LAGER		BEARING	PALIER	COJINETE
2	52	1 609 480 890		SICHERUNGSRING	øe 17	RETAINING RING	CIRCLIP	ANILLO SEGURIDAD
2	53	1 609 111 120		RING	øi 47	RING	BAGUE	ANILLO
2	54	1 609 341 080		ÖLDICHTUNG		OIL SEAL	ÉTANCHÉITÉ HUILE	RETENCIÓN ACEITE
2	55	3 609 340 060		PLEUELSTANGE		CONNECTING-ROD	BIELLE	BIELA
2	56	3 609 340 080		STECKER		PIN	FICHE	CLAVIJA
2	57	3 609 340 070		STANGE		PIN	TIGE	VARILLA
2	58	3 609 260 460		ÖLDICHTUNG		OIL SEAL	ÉTANCHÉITÉ HUILE	RETENCIÓN ACEITE
2	59	3 609 600 180		O-RING	ø 7,66x1,78	O-RING	JOINT TORIQUE	GUARNICIÓN OR
2	60	3 609 341 010		SCHEIBE		PLATE	DISQUE	DISCO
2	61	3 609 342 740		KOLBEN	ø 15	PISTON	PISTON	PISTÓN
2	62	3 609 341 020		UNTERLEGSSCHEIBE	6x10x1	WASHER	RONDELLE	ARANDELA
2	63	3 609 850 670		SCHRAUBE	TCEI M 6x35	SCREW	VIS	TORNILLO
2	64	1 609 340 170		WELLE		SHAFT	ARBRE	EJE
2	65	1 609 120 680		O-RING		O-RING	JOINT TORIQUE	GUARNICIÓN OR
2	66	1 609 600 180		O-RING	ø 7,66x1,78	O-RING	JOINT TORIQUE	GUARNICIÓN OR
2	67	1 609 022 040		STANGE		PIN	TIGE	VARILLA
2	68	1 609 021 630		FEDER		SPRING	RESSORT	RESORTE
2	69	1 609 021 650		UNTERLEGSSCHEIBE		WASHER	RONDELLE	ARANDELA
2	70	1 609 260 820		O-RING		O-RING	JOINT TORIQUE	GUARNICIÓN OR
2	71	1 609 344 830		VERBINDUNGSSTÜCK		FITTING	RACCORD	RACOR
2	72	1 609 042 580		SATZ TSS		TSS KIT	KIT TSS	KIT TSS
2	73	1 609 560 520		FEDER		SPRING	RESSORT	RESORTE
2	74	1 609 250 280		KUGEL		BALL	BILLE	BOLA
2	75	1 609 480 480		O-RING	ø 4,48x1,78	O-RING	JOINT TORIQUE	GUARNICIÓN OR
2	76	1 609 982 520		SCHLAUCHANSCHLUSS		HOSE TAIL	ABOUT	PORTAGOMA
2	77	1 609 349 285		PUMPE KPL.		PUMP ASSEMBLY	PRÉ-MONTAGE POMPE	PREMONTAJE BOMBA
2	78	1 609 349 204		KOPF KPL.		HEAD ASSEMBLY	PRÉ-MONTAGE TÊTE	PREMONTAJE CABEZAL
2	79	1 609 042 579		EINSTELLUNGVENTIL SATZ		VALVE KIT ADJUSTMENT	KIT VANNE DE RÉGLAGE	KIT VÁLVULA DE AJUSTE

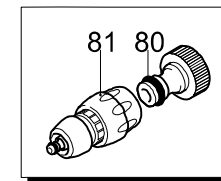
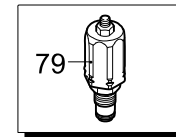
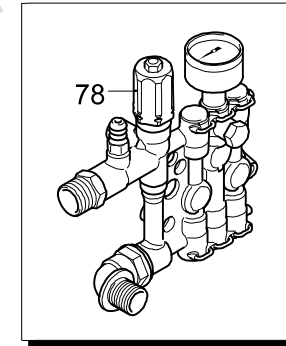
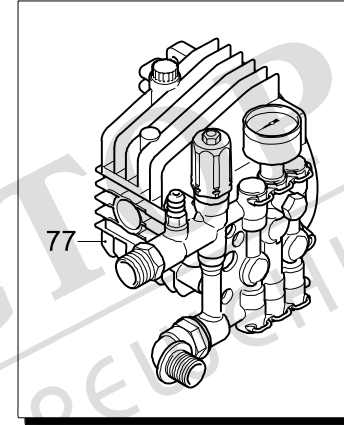
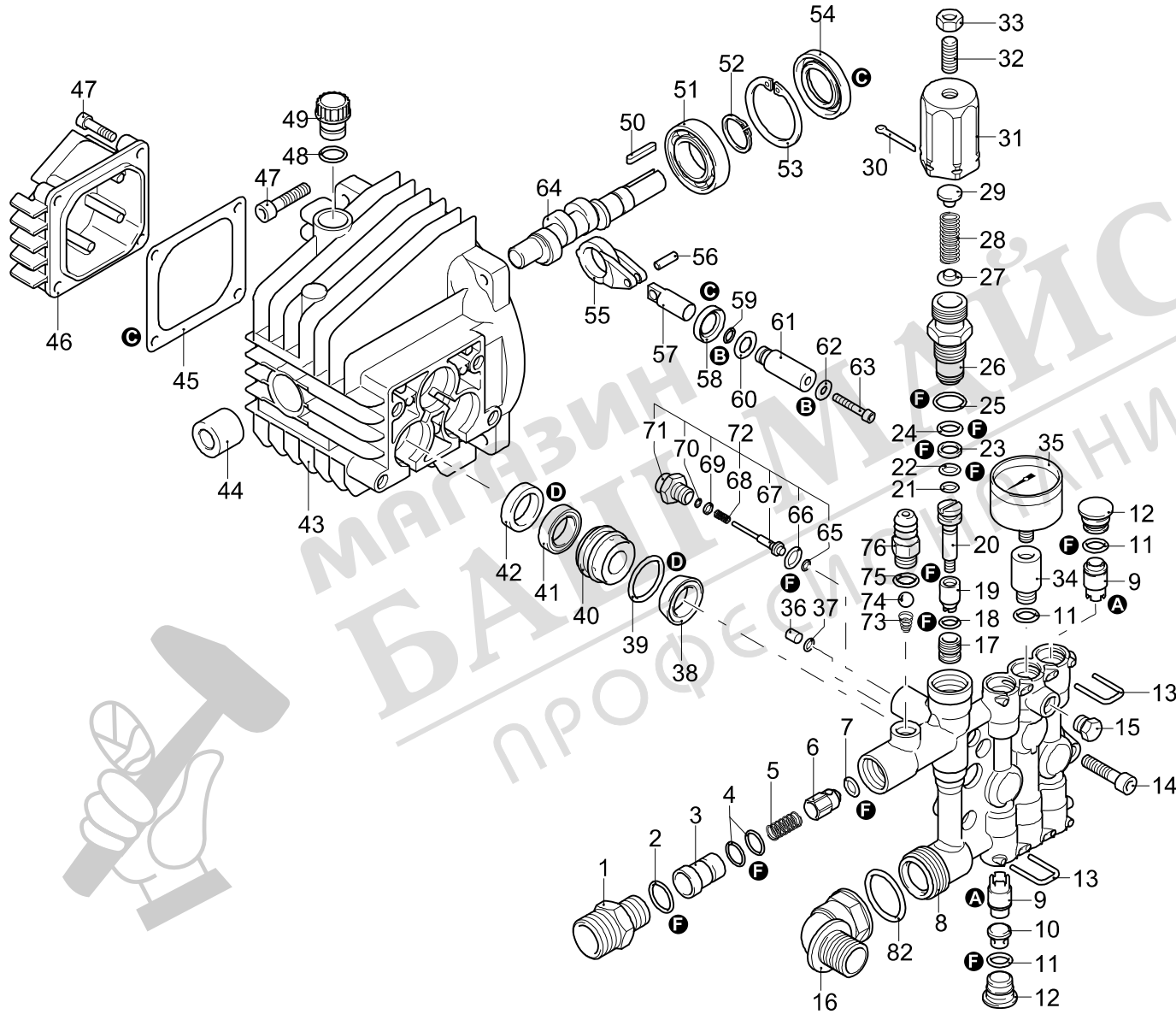

- A
- B
- C
- D
- E
- F
- G





HW151

**2**
 Pumpe  
 Pump  
 Pompe  
 Bomba



Seite / Page	Pos.	HW151	Teil-Nr. Part No. No. de pièce No. de pieza	Hinweise Notes Renseign. Nota	Bezeichnung	Spezifikation Specification	Description	Désignation	Denominación
2	80	1	609 082 130		WASSERFILTER		WATER SUCTION FILTER	FILTRE	FILTRO
2	81	1	609 040 086		SCHLAUCHKUPPLUNG		COUPLING SLEEVE	MANCHON D'ACCOUPLMENT	ACOPLAMIENTO P. TUBOS
2	82	1	609 344 970		O-RING		O-RING	JOINT TORIQUE	GUARNICIÓN OR

 МАГАЗИН  
 БАШ

 МАЙСТОР  
 ПРОФЕСИОНАЛНИ РЕШЕНИЯ

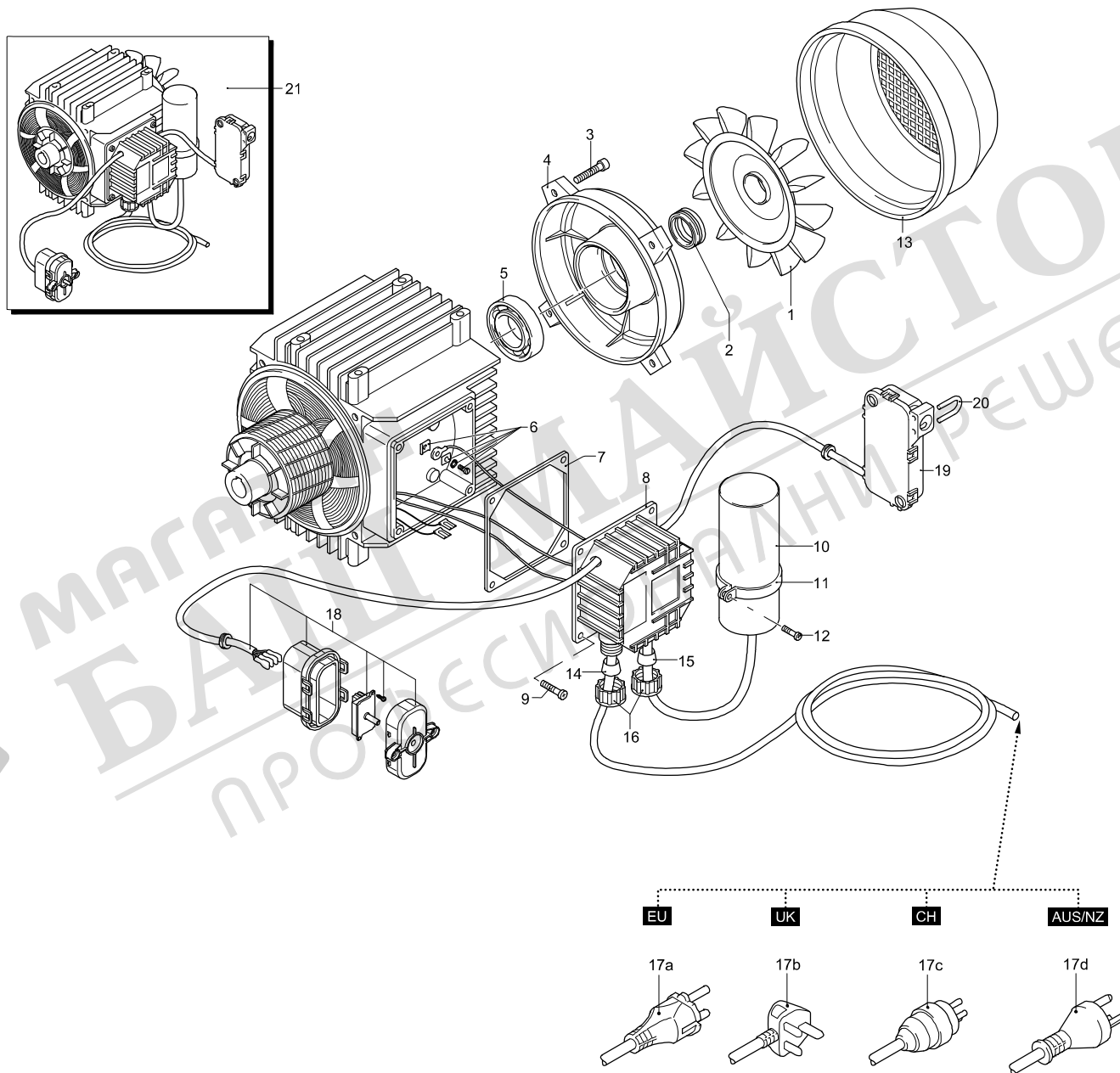

HW151

3

Motor  
Motor  
Moteur  
Motor

Seite / Page	Pos.	HW151	Teil-Nr. Part No. No. de pièce No. de pieza	Hinweise Notes Renseign. Nota	Bezeichnung	Spezifikation Specification	Description	Désignation	Denominación
3	1	1	609 260 300		LÜFTER		FAN	VENTILATEUR	VENTILADOR
3	2	1	609 340 350		ÖLDICHTUNG		OIL SEAL	ÉTANCHÉITÉ HUILE	RETENCIÓN ACEITE
3	3	1	609 260 760		SCHRAUBE	TCEI M5x20	SCREW	VIS	TORNILLO
3	4	1	609 340 320		SCHUTZSCHILD		SHIELD	BOUCLIER	ESCUDO
3	5	1	609 340 340		LAGER		BEARING	PALIER	COJINETE
3	6	1	609 269 100		KLEMME		CLAMP	ÉTAU	MORDAZA
3	7	1	609 340 780		DICHTUNG		GASKET	JOINT	GUARNICIÓN
3	8	1	609 341 832		SCHALTERGEHÄUSE		SWITCH BOX	CARTER	CÁRTER
3	9	1	609 261 560		SCHRAUBE	3,9x16	SCREW	VIS	TORNILLO
3	10	1	609 263 520		KONDENSATOR	40 µF	CAPACITOR	CONDENSATEUR	CONDENSADOR
3	11	1	609 982 550		SCHELLE		CLAMP	COLLIER	ABRAZADERA
3	12	4	609 261 560		SCHRAUBE	3,9x16	SCREW	VIS	TORNILLO
3	13	1	609 342 040		LÜFTERDECKEL		FAN COWLING	CACHE VENTILATEUR	CUBRE-VENTILADOR
3	14	1	609 340 660		GUMMIFUß		RUBBER FOOT	CAPSULE CAOUTCHOUC	GOMA
3	15	1	609 340 650		GUMMIFUß		RUBBER FOOT	CAPSULE CAOUTCHOUC	GOMA
3	16	2	609 340 640		NUTMUTTER		RING NUT	ÉCROU	VIROLA
3	17a	1	609 760 450		KABEL MIT STECKER	EU (SCHUKO) L=5200 mm	POWER SUPPLY CORD W. PLUG	CÂBLE AVEC PRISE	CABLE CON ENCHUFE
3	17b	1	609 681 510		KABEL MIT STECKER	UK	POWER SUPPLY CORD W. PLUG	CÂBLE AVEC PRISE	CABLE CON ENCHUFE
3	17c	1	609 683 250		KABEL MIT STECKER	CH	POWER SUPPLY CORD W. PLUG	CÂBLE AVEC PRISE	CABLE CON ENCHUFE
3	17d	1	609 760 630		KABEL MIT STECKER	AUS, NZ	POWER SUPPLY CORD W. PLUG	CÂBLE AVEC PRISE	CABLE CON ENCHUFE
3	18	1	609 909 209		SCHALTER KPL.		SWITCH COMPL.	INTERRUPTEUR CPL.	INTERRUPTOR CPL.
3	19	1	609 029 752		VORMONTAGESATZ TSS		TSS BOX ASSEMBLY	PRÉ-MONTAGE BOÎTIER TSS	PREMONTAJE CAJA TSS
3	20	1	609 022 200		KLEMME		FORK	COLLIER	HORQUILLA
3	21	1	609 044 476		MOTOR	EU (SCHUKO) 1,7 HP 230V/50Hz 2P	MOTOR	MOTEUR	MOTOR
3	21	1	609 044 500		MOTOR	CH	MOTOR	MOTEUR	MOTOR
3	21	1	609 044 506		MOTOR	AUS, NZ	MOTOR	MOTEUR	MOTOR
3	21	1	609 044 499		MOTOR	UK	MOTOR	MOTEUR	MOTOR

HW151

4

Schlauchtrommel  
Hose reel  
Tambour de tuyau  
Tambor para mangas

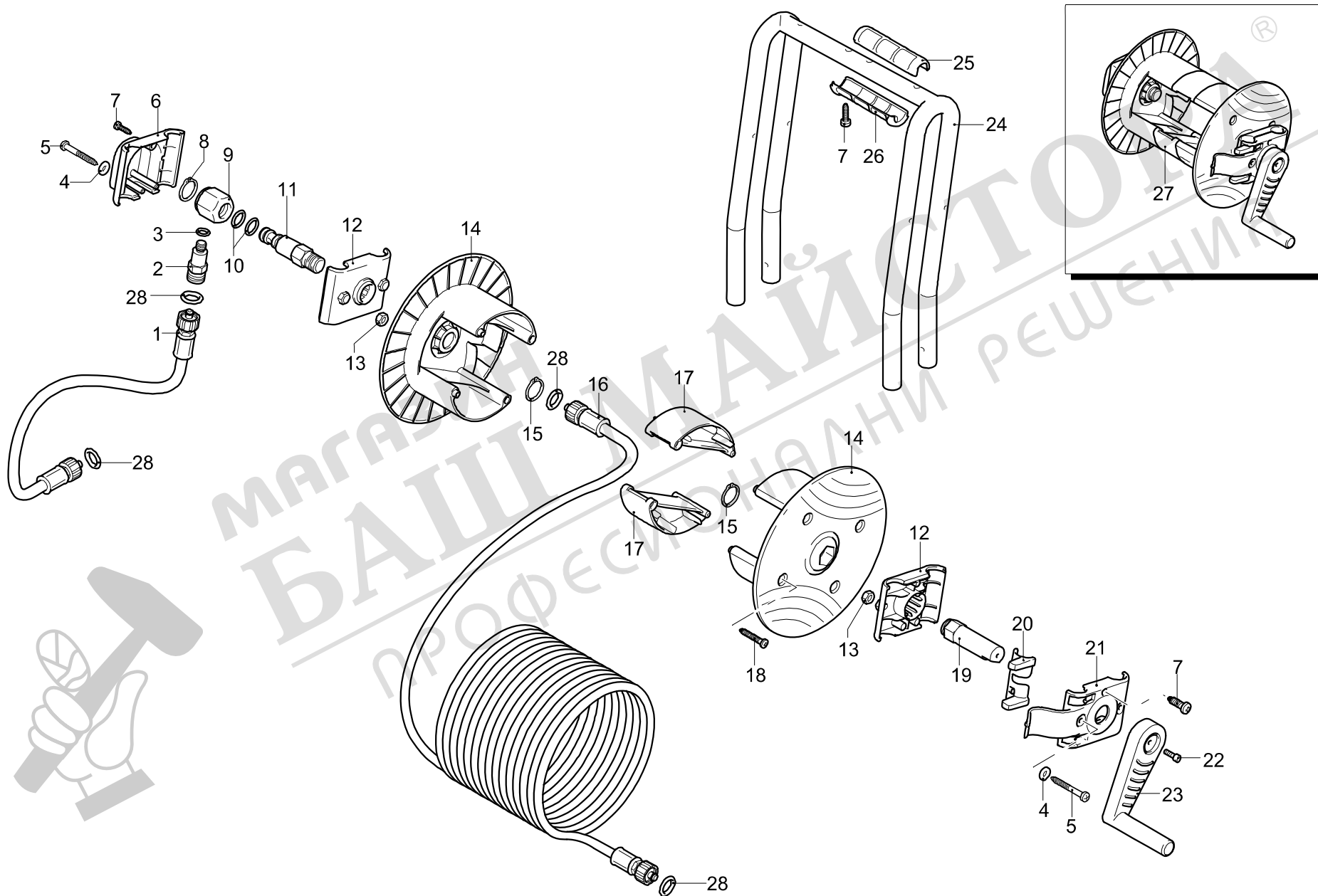

HW151

4

Schlauchtrommel  
Hose reel  
Tambour de tuyau  
Tambor para mangas



Seite / Page	Pos.	HW151	Teil-Nr. Part No. No. de pièce No. de pieza	Hinweise Notes Renseign. Nota	Bezeichnung	Spezifikation Specification	Description	Désignation	Denominación
4	1	1	609 580 310		HOCHDRUCKSCHLAUCH	1/4" M22x1,5(F) MAX 160 BAR 0,75m	HIGH PRESSURE HOSE	TUYAU HAUTE PRESSION	TUBO
4	2	1	609 600 260		VERBINDUNGSSTÜCK		FITTING	RACCORD	RACOR
4	3	1	609 820 510		O-RING	ø 10,82x1,78	O-RING	JOINT TORIQUE	GUARNICIÓN OR
4	4	4	609 470 390		UNTERLEGSCHLEIBE		WASHER	RONDELLE	ARANDELA
4	5	4	609 580 330		SCHRAUBE		SCREW	VIS	TORNILLO
4	6	1	609 580 150		ABDECKUNG		BRACKET	ÉTRIER	ESTRIBO
4	7	6	609 100 300		SCHRAUBE	5x16	SCREW	VIS	TORNILLO
4	8	1	609 480 890		SICHERUNGSRING	øe 17	RETAINING RING	CIRCLIP	ANILLO SEGURIDAD
4	9	1	609 600 220		VERBINDUNGSSTÜCK		FITTING	RACCORD	RACOR
4	10	2	609 390 080		O-RING	ø 11,91x2,62	O-RING	JOINT TORIQUE	GUARNICIÓN OR
4	11	1	609 580 340		ZAPFEN		HUB PIN	PIVOT	PERNO
4	12	2	609 580 160		ACHSLAGER		AXLE BEARING	PALIER	COJINETE DEL EJE
4	13	4	609 680 750		MUTTER		NUT	ECROU	TUERCA
4	14	2	609 360 230		SCHLAUCHTROMMEL		HOSE REEL	TAMBOUR DE TUYAU	TAMBOR PARA MANGAS
4	15	2	609 380 420		SICHERUNGSRING	øe 22	RETAINING RING	CIRCLIP	ANILLO SEGURIDAD
4	16	1	609 083 550		SCHLAUCH		PIPE	TUYAU	TUBO
4	17	2	609 580 120		DISTANZSTÜCK		SPACER	ENTRETOISE	SEPARADOR
4	18	8	609 021 780		SCHRAUBE		SCREW	VIS	TORNILLO
4	19	1	609 580 350		ACHSE		HUB PIN	PIVOT	PERNO
4	20	1	609 580 130		HAKEN		HOOK	CROCHET	GANCHO
4	21	1	609 580 140		BÜGEL		BRACKET	ÉTRIER	ESTRIBO
4	22	1	609 360 360		SCHRAUBE	TCEI M5x10	SCREW	VIS	TORNILLO
4	23	1	609 360 150		KURBEL		CRANK LEVER	MANIVELLE	MANIVELA
4	24	1	609 580 080		RAHMEN		FRAME	CADRE	BASTIDOR
4	25	2	609 580 180		GRIFFABDECKUNG		HANDLE COVER	CAPOT DE POIGNÉE	CUBIERTA DEL MANGO
4	26	2	609 580 090		GRIFFABDECKUNG		HANDLE COVER	CAPOT DE POIGNÉE	CUBIERTA DEL MANGO
4	27	1	609 042 581		SCHLAUCHTROMMEL KPL.		HOSE REEL ASSEMBLY	PRÉ-MONTAGE ENROULEUR	PREMONTAJE ENROLLADOR TUBO
4	28	4	609 000 770		O-RING	ø 10x2	O-RING	JOINT TORIQUE	ANILLO DE GUARNICIÓN

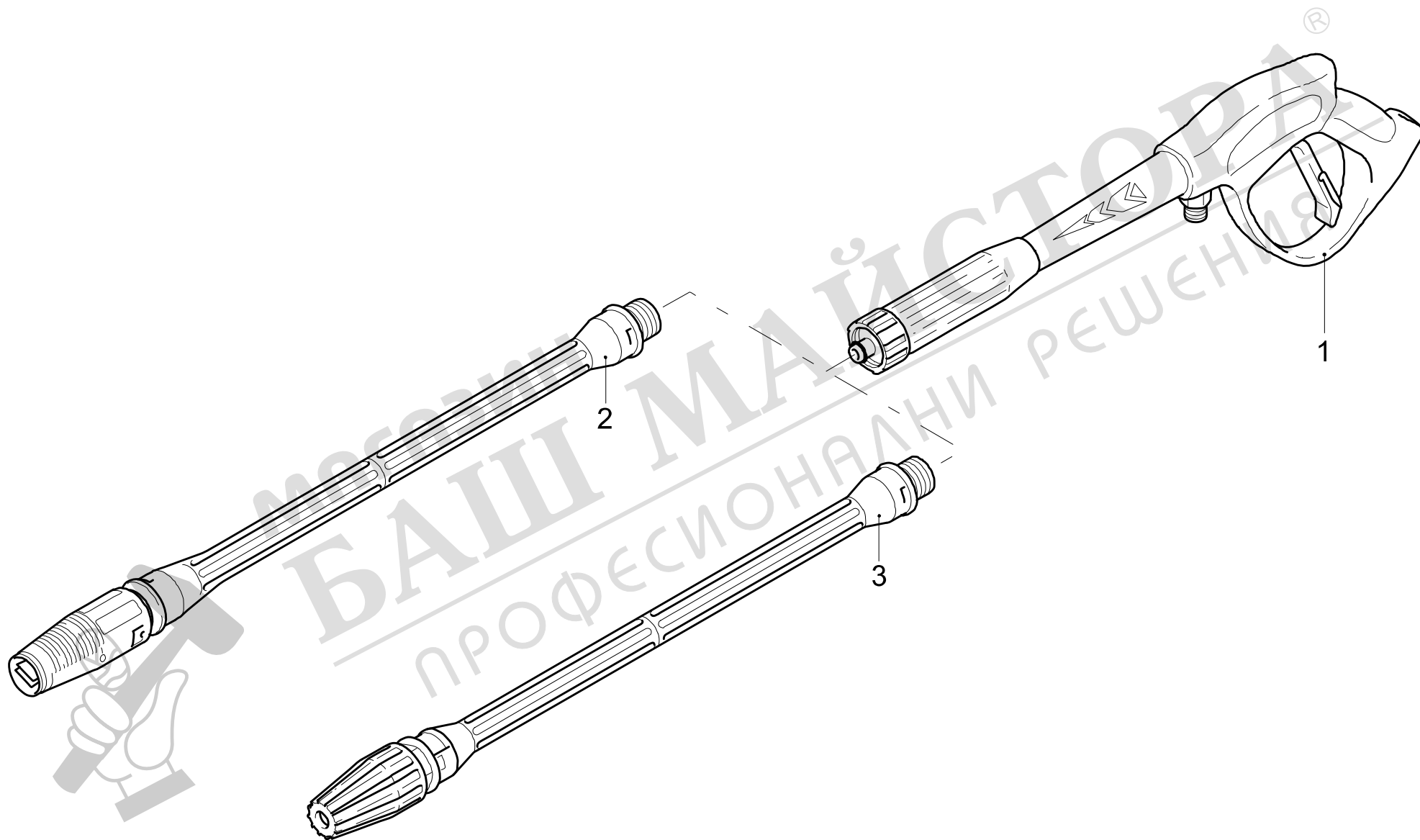

HW151

**5**Zubehör  
Accessories  
Accessoires  
Accesorios**Makita**<sup>®</sup>

Seite / Page	Pos.	HW151	Teil-Nr. Part No. No. de pièce No. de pieza	Hinweise Notes Renseign. Nota	Bezeichnung	Spezifikation Specification	Description	Désignation	Denominación
5	1	1	609 041 154		SPRÜHHANDGRIFF		PISTOL	PISTOLET	PISTOLA
5	2	1	609 040 551		LANZE MIT ARRETIERBARER DÜSE		ADJUSTABLE SPRAY LANCE	LANCE	LANZA
5	3	1	609 040 167		TURBOLANZE		ROTO POWER PRO	LANCE, TURBO	LANZA, TURBO



МАГАЗИН  
БАШ МАЙСТОР  
ПРОФЕСИОНАЛНИ РЕШЕНИЯ

МАГАЗИН  
БАШ МАЙСТОРА®  
ПРОФЕССИОНАЛНИ РЕШЕНИЯ

	Zeichenerklärung	Key to symbols	Légende	Explicación de símbolos
=> 1999999 2000000 => 2003.04 => TI 2003/07 <b>Acc.</b> = { <b>m</b> <b>Corr.</b>	Produktion bis Serien-Nr. Neues Teil ab Serien-Nr. Neues Teil ab Jahr / Monat Siehe Technische Information Jahr / Nr. Zubehör (nicht im Lieferumfang) Keine Serienausführung, jedoch verwendbar Beinhaltet Positions-Nr. Meterware Druckfehlerberichtigung	Production to serial number New part from serial number New part from Year / Month See Technical Information Year / No. Accessories (not included in the delivery inventory) No standard execution, may be used Contains item number Sold by the meter Error correction	Production jusqu'à n° de série Nouvelle pièce à partir du n° de série Nouvelle pièce à partir de année / mois Voir information technique année / n° Accessoires (non compris dans la livraison) Aucune exécut. en série, cependant utilisable contient n° de numéro Au mètre Rectification d'erreurs	Producción hasta N° de serie Pieza nueva a partir de N° de serie Pieza nueva a partir de año / mes Véase inform. técnico año / N° Accesorios (no incluido en la extensión del suministro) No es de serie, pero sirve Contiene pos N° Por metro Fe de erratas
	Änderungen vorbehalten	Specifications subject to change without notice	Changements sans préavis	Mejoras constructivas sin previo aviso