



Makita Werkzeug Ges.m.b.H.

Kolpingstrasse 13, 1230 Wien

Tel: 01 / 616 27 30 - 0*

Fax: 01 / 616 27 30 - 40

Mail: verkauf@makita.at

Web: www.makita.at

Makita Service Information / Model: LS1040

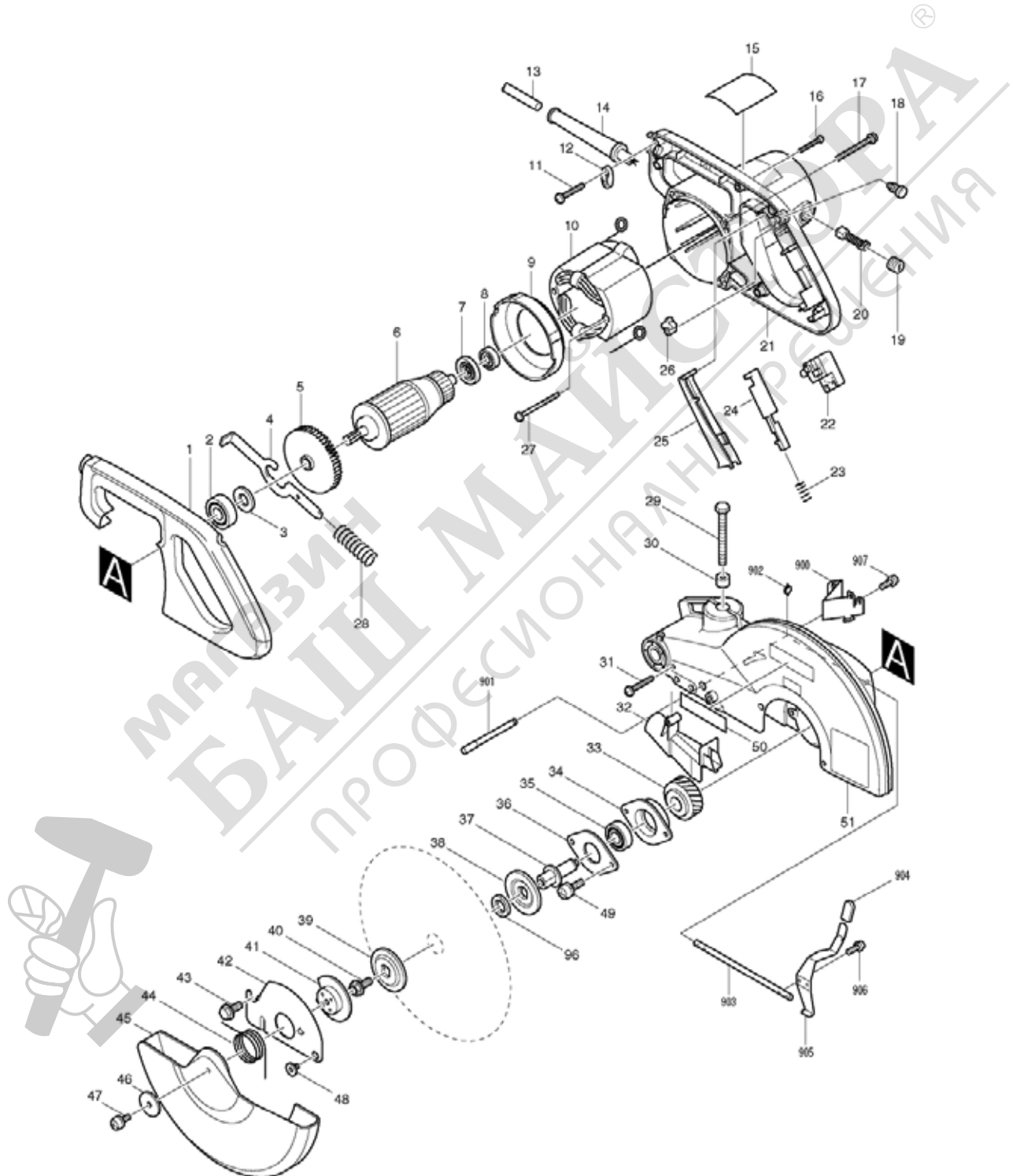



Makita Werkzeug Ges.m.b.H.

Kolpingstrasse 13, 1230 Wien

Tel: 01 / 616 27 30 - 0*

Fax: 01 / 616 27 30 - 40

Mail: verkauf@makita.at

Web: www.makita.at

Makita Service Information / Model: LS1040

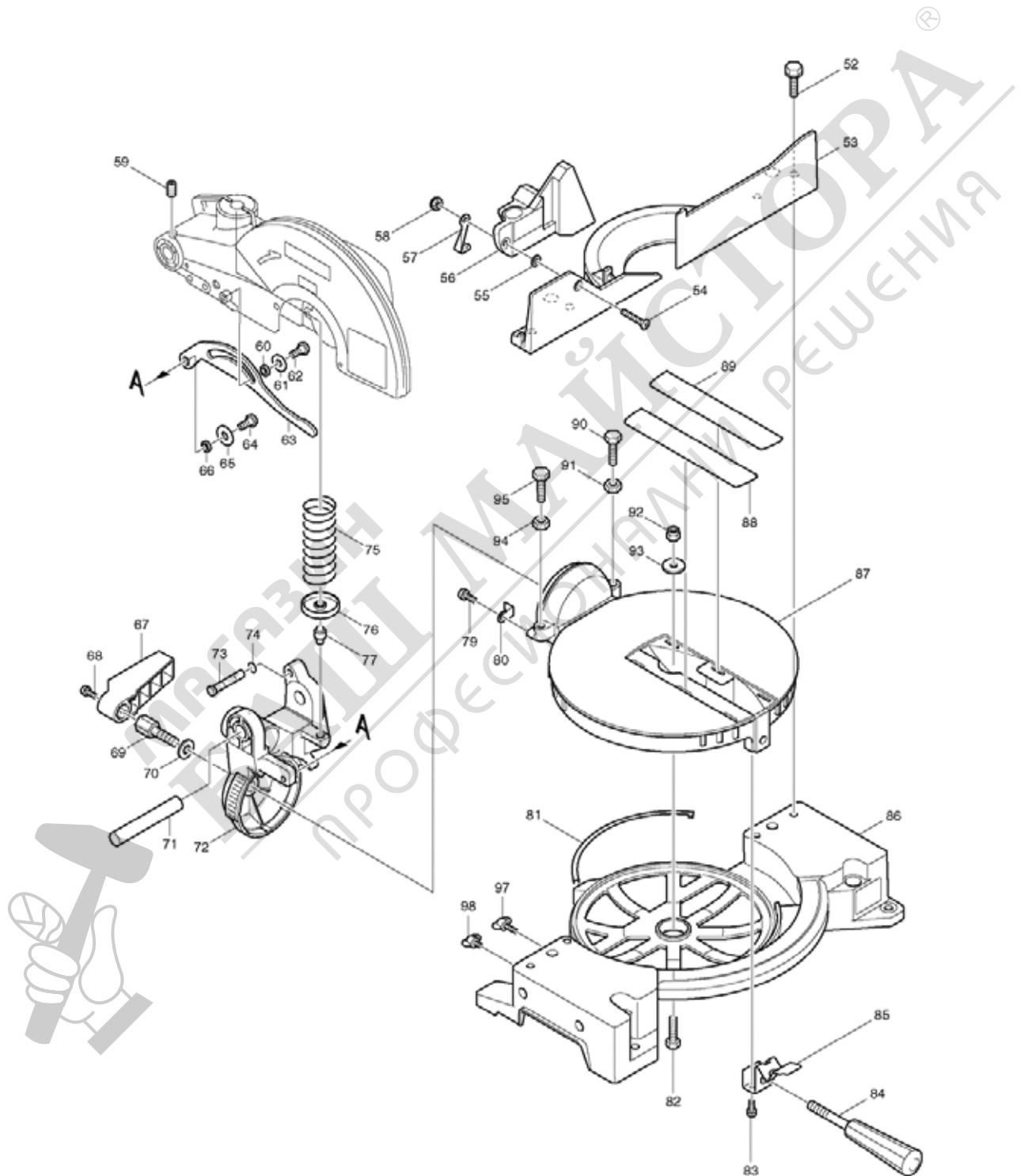



Makita Werkzeug Ges.m.b.H.

Kolpingstrasse 13, 1230 Wien

Tel: 01 / 616 27 30 - 0*

Fax: 01 / 616 27 30 - 40

Mail: verkauf@makita.at

Web: www.makita.at

Makita Service Information / Model: LS1040

POS	Bestell-Nr.	Artikelbeschreibung	Stk.	Stk.Preis
1	416004-6	GRIFFSCHALE LS1040/F	1	N/A
2	211206-7	KUGELLAGER 6202LLB	1	N/A
3	253853-8	U-SCHEIBE 15 HR1800/DA4030	1	N/A
3.2	267280-3	U-SCHEIBE 15 LS/LH/1040/F	1	N/A
4	343641-2	SPINDELARRETIERUNG LS1030/40/F	1	N/A
5	241909-9	LÜFTERRAD 80 LS/LH/1040/F	1	N/A
6	516718-8	ANKER LS/LH/1040/F	1	N/A
6		*** INC. 2,3,5,7,8		N/A
7	681640-9	ISOLIERSCHEIBE LS1040/KP312S/	1	N/A
8	211061-7	KUGELLAGER 6000LLB	1	N/A
9	416442-2	LUFTABLEITPLATTE LS1040/F	1	N/A
10	526068-3	FELD LS1040/F	1	N/A
11	265995-6	SELBSTSCHN.SCHRA 4x18 BO5030	2	N/A
12	687063-9	KABELKLEMMPLATTE HT-345	1	N/A
12.2	687052-4	KABELKLEMMPLATTE	1	N/A
13	665865-3	KABEL 1.0-2-2.5 N5900B/TD101	1	N/A
14	682540-6	KABELSCHUTZ 9.3-90	1	N/A
15	851559-8	NAME PLATE LS1040	1	N/A
16	265995-6	SELBSTSCHN.SCHRA 4x18 BO5030	5	N/A
17	911383-2	SCHRAUBE M6x60	4	N/A
18	411478-6	Einschalt-Sicherheitsstift	1	N/A
19	643650-4	KOHLKAPPE 6.5x18 (CB153)	2	N/A
20	181044-0	KOHL CB-153 (CB-152)	1	N/A
21	150786-7	MOTORGEHÄUSE LS1040	1	N/A
21.2	153794-7	MOTORGEHÄUSE LS1040 neu	1	N/A
21.3	154561-3	MOTORGEHÄUSE LS1040 neuer	1	N/A
22	651923-1	SCHALTER TG70B	1	N/A
23	231457-6	DRUCKFEDER 3 UH4510A/LS1013/	1	N/A
24	416000-4	ENTRIEGELUNGSHEBEL LS1013/40F	1	N/A
25	415999-0	SCHALTERHEBEL LS1013/1040F/12	1	N/A
26	414546-4	SCHALTERNOCKE LS1013/1214/104	1	N/A
27	266029-8	SELBSTSCHNEID. SCHRAUBE 5x65	2	N/A
28	231297-2	DRUCKFEDER LS1030/1040/2704/L	1	N/A
29	251667-9	6-KANTSCHRAUBE M8x75	1	N/A
30	262511-5	GUMMIHÜLSE 6 262511-5	1	N/A
31	265995-6	SELBSTSCHN.SCHRA 4x18 BO5030	1	N/A
32	416007-0	SCHUTZANSCHLAG LS1040/F	1	N/A
32.2	453695-2	SCHUTZANSCHLAG LS1040/F	1	N/A
33	226465-0	ZAHNRAD 42 LS/LH/1040/F	1	N/A
34	316821-3	LAGERSCHILD LS/LH/1040/F	1	N/A



Makita Werkzeug Ges.m.b.H.

Kolpingstrasse 13, 1230 Wien

Tel: 01 / 616 27 30 - 0*

Fax: 01 / 616 27 30 - 40

Mail: verkauf@makita.at

Web: www.makita.at

Makita Service Information / Model: LS1040

POS	Bestell-Nr.	Artikelbeschreibung	Stk.	Stk.Preis
35	211256-2	KUGELLAGER 6203LLB 211256-2	1	N/A
36	285685-5	LAGERABDECKUNG 64 LS/LH/1040/F	1	N/A
37	322865-3	SPINDEL LS/LH/1040/F	1	N/A
38	224333-1	FLANSCH 53 LS1013/1040/F/LH1	1	N/A
39	224333-1	FLANSCH 53 LS1013/1040/F/LH1	1	N/A
40	265355-2	FLANSCHSCHRAUBE M8x20	1	N/A
41	343639-9	SCHUTZHALTERUNG LS1040/1013/LH	1	N/A
42	344380-7	MITTELDECKEL LS/LH/1040/F	1	N/A
43	265324-3	FLANSCHSCHRAUBE M8x12	1	N/A
44	231593-8	RÜCKZUGSFEDER 36 LS1040/F/30	1	N/A
45	416003-8	BEWEGL. SCHUTZ LS1040/F	1	N/A
46	267136-0	SCHEIBE 5	1	N/A
47	911213-7	SCHRAUBE M5x12	1	N/A
48	265985-9	INBUSSCHRAUBE M6 LS/LH/1040/F	1	N/A
49	911223-4	SCHRAUBE M5x16	2	N/A
50	819064-1	ETIKETTE " M A K I T A "	1	N/A
51	151490-1	SÄGEBLATTGEHÄUSE LS1040/F	1	N/A
51.2	151490-1	SÄGEBLATTGEHÄUSE LS1040/F	1	N/A
51.3	154560-5	SÄGEBLATTGEHÄUSE LS1040/F	1	N/A
51.4	188330-0	SÄGEBLATTGEHÄUSE LS1040/F neu	1	N/A
51.4		*** INC.E22		N/A
51.5	188330-0	SÄGEBLATTGEHÄUSE LS1040/F neu	1	N/A
51.5		*** INC.E22		N/A
51.6	140655-0	SÄGEBLATTGEHÄUSE LS1040/F	1	N/A
51.7	141570-1	SÄGEBLATTGEHÄUSE LS1040/F	1	N/A
52	921451-3	6-KANTSCHRAUBE M8X30 921451-	4	N/A
52.2	265488-3	6-KANTSCHRAUBE M8x30 LS1040F/L	4	N/A
53	316826-3	PARALLELANSCHLAG LS1040/F	1	N/A
53.2	316826-3	PARALLELANSCHLAG LS1040/F	1	N/A
53.3	318847-1	GUIDE RULE	1	N/A
54	912342-9	SENKKOPFSCHRAUBE M6x25	1	N/A
55	253715-0	SCHEIBE 6	1	N/A
56	150760-5	ANSCHLAGPLATTE LS1040/F	1	N/A
56.2	150760-5	ANSCHLAGPLATTE LS1040/F	1	N/A
56.3	154559-0	ANSCHLAGPLATTE LS1040/F neu	1	N/A
57	344476-4	BEWGL.ANSCHLAGPL. (KLEIN) LS10	1	N/A
58	252014-7	6-KANTMUTTER M6-10 LS1013/40	1	N/A
59	251961-9	INBUSSCHRAUBE M6x10	1	N/A
60	257162-7	RING 7 LS1030/1040/F/LH1040/F	1	N/A
61	253823-7	SCHEIBE 7 BHR241	1	N/A



Makita Werkzeug Ges.m.b.H.

Kolpingstrasse 13, 1230 Wien

Tel: 01 / 616 27 30 - 0*

Fax: 01 / 616 27 30 - 40

Mail: verkauf@makita.at

Web: www.makita.at

Makita Service Information / Model: LS1040

POS	Bestell-Nr.	Artikelbeschreibung	Stk.	Stk.Preis
62	265984-1	INBUSSCHRAUBE M6 MIT BUND	1	N/A
63	344377-6	Gelenkplatte LS/LH/1040/F	1	N/A
64	265984-1	INBUSSCHRAUBE M6 MIT BUND	1	N/A
65	253823-7	SCHEIBE 7 BHR241	1	N/A
66	257162-7	RING 7 LS1030/1040/F/LH1040/F	1	N/A
67	416006-2	KLEMMHEBEL 100	1	N/A
68	911113-1	SCHRAUBE M4x10 BST110	1	N/A
69	265437-0	SCHRAUBE M10 LS/LH/1040/F	1	N/A
70	253024-7	SCHEIBE 10	1	N/A
71	256836-7	STIFT 16 LS/LH/1040/F	1	N/A
72	150664-1	ARM LS1040/F	1	N/A
72.2	150664-1	ARM LS1040/F	1	N/A
72.3	154463-3	ARM LS/LH/1040/F	1	N/A
73	322317-4	FIXIERSTIFT LS1040/F	1	N/A
74	213021-5	O-RING 5	1	N/A
75	233152-4	DRUCKFEDER 28 LS1040/F	1	N/A
76	343638-1	FEDERHALTER LS1030 (NUR LS1	1	N/A
76.2	344464-1	FEDERHALTER LS/LH/1013/1040	1	N/A
77	256260-4	STIFT 8 LS1040 BITTE 25628	1	N/A
77.2	256280-8	STIFT 8 LS/LH/1040/F	1	N/A
79	911113-1	SCHRAUBE M4x10 BST110	1	N/A
80	344385-7	PFEIL F. WINKELGRADE LS/LH104	1	N/A
81	343799-7	GLEITPLATTE LS/LH/1040/F	3	N/A
82	921452-1	SCHRAUBE M8x30 LS/LH/1040/F	1	N/A
83	911213-7	SCHRAUBE M5x12	2	N/A
84	273495-2	GRIFF 32	1	N/A
85	344381-5	WINKELFIXIERFEDER LS/LH1040/F	1	N/A
86	150759-0	GRUNDPLATTE LS1040/F	1	N/A
86.2	150759-0	GRUNDPLATTE LS1040/F	1	N/A
86.3	154558-2	GRUNDPLATTE LS1040/F	1	N/A
87	316824-7	DREHTELLER LS/LH/1040/F	1	N/A
87.2	316824-7	DREHTELLER LS/LH/1040/F	1	N/A
88	416001-2	GLEITPLATTE LS1040/F	1	N/A
89	416001-2	GLEITPLATTE LS1040/F	1	N/A
90	921452-1	SCHRAUBE M8x30 LS/LH/1040/F	1	N/A
91	931402-8	MUTTER M8 BHR241	1	N/A
92	252105-4	6-KANTMUTTER M8-13	1	N/A
93	253762-1	SCHEIBE 8 LS/LH/1040/F	1	N/A
94	931402-8	MUTTER M8 BHR241	1	N/A
95	921452-1	SCHRAUBE M8x30 LS/LH/1040/F	1	N/A



Makita Werkzeug Ges.m.b.H.

Kolpingstrasse 13, 1230 Wien

Tel: 01 / 616 27 30 - 0*

Fax: 01 / 616 27 30 - 40

Mail: verkauf@makita.at

Web: www.makita.at

Makita Service Information / Model: LS1040

POS	Bestell-Nr.	Artikelbeschreibung	Stk.	Stk.Preis
96	257137-6	RING 16 LS1013/LS1040/F	1	N/A
96.2	257262-3	RING 16 alle LS/LH/LF/Sägen	1	N/A
97	251887-5	FLÜGELSCHRAUBE M6x10	1	N/A
98	265708-5	SCHRAUBE M6x20 LS/LH/1040/F	2	N/A
98.2	911333-7	SCHRAUBE M6x20	2	N/A
900	344572-8	ARRETIERPLATTE LS1040/F	1	N/A
901	323720-2	SPERRSTIFT 8 LS1040/F	1	N/A
901.2	326176-8	SPERRSTIFT 8 LS1040/F	1	N/A
902	231633-2	RÜCKZUGFEDER 8 LS1040/1214/F	1	N/A
903	323721-0	STANGE 8 LS1040/F	1	N/A
904	421589-9	KAPPE LS1013/0714/F/BLS820S/L	1	N/A
905	344573-6	FESTSTELLHEBEL LS1040	1	N/A
905.2	345803-8	FESTSTELLHEBEL LS1040/F neu	1	N/A
905.3	346619-4	FESTSTELLHEBEL LS1040/F neu	1	N/A
906	911113-1	SCHRAUBE M4x10 BST110	2	N/A
907	911113-1	SCHRAUBE M4x10 BST110	2	N/A
908	424018-1	Zusatzhebel LS1040 neu	1	N/A
1001	411478-6	Einschalt-Sicherheitsstift	2	N/A
1002	762001-3	Winkeleinsteldreieck	1	N/A
1003	782212-4	STECKSCHLÜSSEL 13	1	N/A
1004	122523-9	STAUBSACK kpl. LS1013/1040/07	1	N/A
1005	122531-0	Kippsicherung LS1040	1	N/A
1005.2	193471-9	SUB PLATE ASS'Y	1	N/A
1005.3	195934-1	PARALLELANSCHLAG LS1040/F	1	N/A
1006	122536-0	Vertikalschraubzwinde	1	N/A
1007	257022-3	RING 16 LS1030/LS1013/1040F/	1	N/A
1008	322312-4	SEITLICHE AUFLAGE LS1040/0714	2	N/A
1008.2	123101-8	SEITLICHE AUFLAGE LS1040/0714	2	N/A
5002	645105-5	KONDENSATOR	1	N/A
5005	651941-9	SCHALTER V-15-2A5	1	N/A
5018	A-80961	HM-SÄGEBLATT (CA.32Z) 255X30/1	1	N/A
5019	646073-5	Drosselspule LS1040F	1	N/A
5022	819064-1	ETIKETTE " M A K I T A "	1	N/A
5022.2	819214-8	MAKITA-Logo-Aufkleber LS1013L/	1	N/A