

DMS 160

DMS 160 A

DMS 160 AT

DMS 160 GYRO

Reservdelar

Spare parts

Ersatzteile

Pieces de rechange

Piezas de repuesto

Ricambi

Peças sobresselente

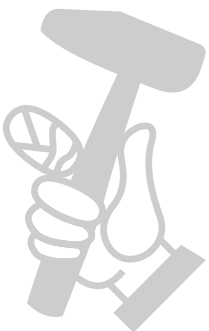

МАГАЗИН
БАШ МАЙСТОР
ПРОФЕСИОНАЛНА РЕЧУЉИЈА

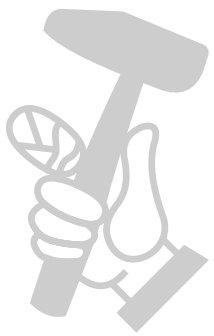

МАГАЗИН
БАШ МАЙСТОРА[®]
ПРОФЕСИОНАЛНИ РЕШЕНИЯ

No.	Pos.	Description	No.	Pos.	Description
501 38 01-01	G	NUT	544 12 85-01	G	DECAL
501 38 46-03	GJ	HANDLE CPL	544 13 24-01	A	CABLE 110V
502 30 01-01	J	ADJUSTMENT SCREW	544 22 27-01	H	SPANNER 30MM
504 02 06-04	E	SHAFT HOLDER	544 22 27-02	H	SPANNER 24MM
504 02 10-01	BC	DECAL	544 23 56-02	GJ	SCREW CPL
504 02 10-02	D	DECAL	544 27 98-01	H	L ALLEN KEY 6MM
504 02 10-04	E	DECAL	544 42 72-01	A	SPANNER 27MM
504 02 31-01	G	SLEEVE INNER	544 42 76-01	A	DMS160 110V ASSY
504 02 33-01	G	RETAINER	544 42 76-02	A	DMS160 230V ASSY
504 03 04-04	B	BASE PLATE DMS 160A	544 42 77-01	A	DECAL 110V
504 03 04-05	C	BASE PLATE DMS 160AT	544 42 77-02	A	DECAL 230V
506 40 05-02	D	PIPE INNER	544 42 78-01	A	DECAL
506 40 05-04	J	EXT. POLE INNER ASSY	544 42 79-01	A	DECAL
506 40 06-06	F	ADJUSTMENT SCREW CPL	544 42 80-01	A	KNOB
506 40 06-08	F	ADJUSTMENT SCREW	544 42 88-01	A	MOTORHOUSE 110V CPL
506 40 11-02	CF	DRILL RACK CPL	544 42 88-02	A	MOTORHOUSE 230V CPL
506 40 14-03	D	BOLT KIT	544 42 91-01	A	CARBON BRUSH
506 40 14-04	D	SPRING CPL	544 42 95-01	A	ELECTRONIC BOX CPL 110V
506 40 16-02	F	KNOB	544 42 95-02	A	ELECTRONIC BOX CPL 230V
506 40 18-02	G	RETAINING RING	544 43 00-01	A	CABEL KIT 230V
506 40 22-02	C	RETAINER CPL	544 43 01-01	A	BACK PLATE CPL
506 40 76-11	E	SHAFT HOLDER WITH WHEEL	544 43 02-01	A	LOCKING SCREW
506 40 77-13	GJ	ADJUSTABLE LEVER CPL	544 43 06-01	A	SHAFT CPL
506 40 79-15	C	BASE PLATE DMS160AT ASSY	544 43 16-01	A	HANDLE CPL
506 40 79-14	B	BASE PLATE DMS160A ASSY	544 43 17-01	A	SHAFT
506 40 80-11	E	BASE PLATE 40T ASSY	544 43 19-01	A	SPRING
506 40 81-06	D	ADJUSTER CPL	544 43 20-01	A	SLEEVE
506 40 81-08	D	ADJUSTER	544 43 21-01	A	SCREW
506 40 83-06	D	EXPANDABLE COLUMN ASSY	544 43 24-01	A	GEARHOUSE CPL
506 40 84-07	D	TOP SUPPORT CPL	544 43 26-01	A	WATER TAP
506 40 85-06	J	EXT. POLE OUTER ASSY	544 43 30-01	A	BUSHING
506 40 86-03	H	TOOL KIT	544 45 72-01	A	KEY
506 40 88-06	F	DRILL RACK DMS ASSY	544 45 84-01	J	VACUUM PLATE CPL.
506 40 91-05	G	GYRO UNIT 40 ASSY	544 45 85-01	J	VACUUM PLATE
531 14 06-02	DE	WING SCREW	544 45 86-01	J	SEALING RING
531 14 06-13	D	WASHER	544 45 87-01	J	VACUUM INLET CONNECT
531 14 06-14	D	NUT	544 45 88-01	J	SCREW
531 14 06-19	E	SCREW	544 45 89-01	J	WASHER
531 14 06-20	BJ	PLUG	544 45 93-01	J	WATER COLLECTOR CPL.
531 14 06-27	E	WASHER	544 45 97-01	BC	WING NUT
531 14 06-43	E	KNOB	544 46 01-01	J	WATER COLLECTOR
531 14 06-44	F	NUT	544 46 02-01	J	SCREW
531 14 06-46	J	ANCHOR BOLT HOLDER	544 83 73-01	A	SHAFT
531 14 06-70	G	STOPSCREW	544 83 74-01	A	SEALING
531 14 07-22	C	WASHER	544 83 75-01	A	BALL BEARING
531 14 07-28	E	WHEEL	544 83 76-01	A	RETAINING RING
531 14 07-30	E	COVER PLATE	544 83 77-01	A	RETAINING RING
531 14 07-62	H	L ALLEN KEY 8MM	544 83 78-01	A	SPACER
531 14 07-57	C	NUT	544 83 80-01	A	GEAR
531 14 07-72	D	PLUG	544 83 81-01	A	SLEEVE
531 14 07-74	E	BASE PLATE 40T	544 83 83-01	A	SPACER
531 14 07-80	D	FORK	544 83 85-01	A	BALL BEARING
531 14 07-85	E	SHAFT HOLDER	544 83 85-01	A	BALL BEARING
531 14 07-87	F	WASHER	544 83 86-01	A	COVER GEAR BOX
531 14 07-88	F	NUT	544 83 87-01	A	BALL BEARING
531 14 07-90	F	SHAFT	544 83 88-01	A	SMC COMPLETE
531 14 07-92	CF	SCREW	544 83 89-01	A	ROTOR 110V CPL
531 14 07-99	G	WASHER	544 83 89-02	A	ROTOR 230V CPL
531 14 08-00	G	SCREW	544 83 90-01	A	BALL BEARING
531 14 08-13	D	PIPE OUTER	544 83 91-01	A	ROTOR 110V
531 14 08-20	C	SCREW	544 83 91-02	A	ROTOR 230V
531 14 08-21	C	SCREW	544 83 92-01	A	GEAR
531 14 08-22	BC	PLUG	544 83 95-01	A	SHAFT
531 14 08-23	C	PLATE	544 83 98-01	A	SCREW KIT
531 14 08-24	BC	SCREW	544 83 99-01	A	SCREW
531 14 08-25	J	NUT	544 84 02-01	A	SCREW
531 14 08-29	J	POLE OUTER			
531 14 08-31	J	STOP PIN			
531 14 09-06	BC	DECAL			
531 14 09-08	E	DECAL			

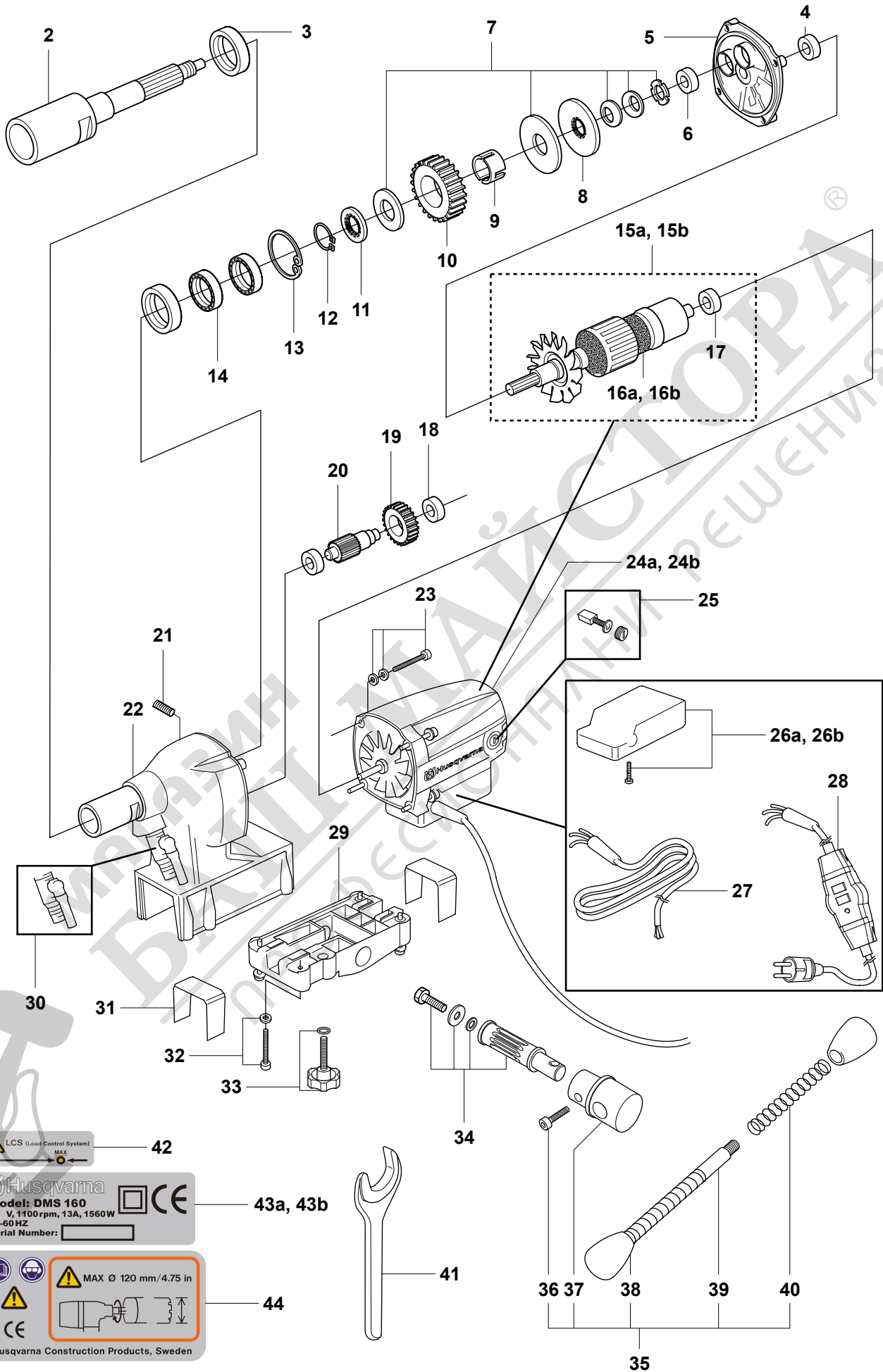
A**DMS 160****1a, 1b**

LCS (Load Control System)

Husqvarna
Model: DMS 160
 V, 1100 rpm, 13A, 1560W
 50-50 HZ
 Serial Number:

MAX Ø 120 mm / 4.75 in

Husqvarna Construction Products, Sweden

Page A
DMS 160

Pos.	Part No.	Description	Quantity	Notes
1a	544 42 76-01	DMS160 110V ASSY	1	Incl. 2-7, 8-15a, 18-35, 41-44
1b	544 42 76-02	DMS160 230V ASSY	1	Incl. 2-7, 8-15b, 18-35, 41-44
2	544 83 73-01	SHAFT	1	
3	544 83 74-01	SEALING	2	
4	544 83 87-01	BALL BEARING	1	
5	544 83 86-01	COVER GEAR BOX	1	
6	544 83 85-01	BALL BEARING	1	
7	544 83 88-01	SMC COMPLETE	1	
8	544 83 83-01	SPACER	1	
9	544 83 81-01	SLEEVE	1	
10	544 83 80-01	GEAR	1	
11	544 83 78-01	SPACER	1	
12	544 83 77-01	RETAINING RING	1	
13	544 83 76-01	RETAINING RING	1	
14	544 83 75-01	BALL BEARING	2	
15a	544 83 89-01	ROTOR 110V CPL	1	Incl. 16a, 17
15b	544 83 89-02	ROTOR 230V CPL	1	Incl. 16b, 17
16a	544 83 91-01	ROTOR 110V	1	
16b	544 83 91-02	ROTOR 230V	1	
17	544 83 85-01	BALL BEARING	1	
18	544 83 85-01	BALL BEARING	2	
19	544 83 92-01	GEAR	1	
20	544 83 95-01	SHAFT	1	
21	544 83 99-01	SCREW	1	
22	544 43 24-01	GEARHOUSE CPL	1	
23	544 83 98-01	SCREW KIT	4	
24a	544 42 88-01	MOTORHOUSE 110V CPL	1	
24b	544 42 88-02	MOTORHOUSE 230V CPL	1	
25	544 42 91-01	CARBON BRUSH	2	
26a	544 42 95-01	ELECTRONIC BOX 110V CPL	1	
26b	544 42 95-02	ELECTRONIC BOX 230V CPL	1	
27	544 13 24-01	CABLE 110V	1	
28	544 43 00-01	CABLE KIT 230V	1	
29	544 43 01-01	BACK PLATE CPL	1	
30	544 43 26-01	WATER TAP	1	
31	544 43 30-01	BUSHING	2	Incl. two pieces
32	544 84 02-01	SCREW KIT	4	
33	544 43 02-01	LOCKING SCREW	1	
34	544 43 06-01	SHAFT CPL	1	
35	544 43 16-01	HANDLE CPL	1	Incl. 36-40
36	544 43 21-01	SCREW	1	
37	544 43 20-01	SLEEVE	1	
38	544 42 80-01	KNOB	2	
39	544 43 17-01	SHAFT	1	
40	544 43 19-01	SPRING	2	
41	544 42 72-01	SPANNER 27MM	1	
42	544 42 79-01	DECAL	1	
43a	544 42 77-01	DECAL 110V	1	
43b	544 42 77-02	DECAL 230V	1	
44	544 42 78-01	DECAL	1	

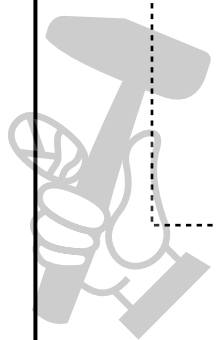
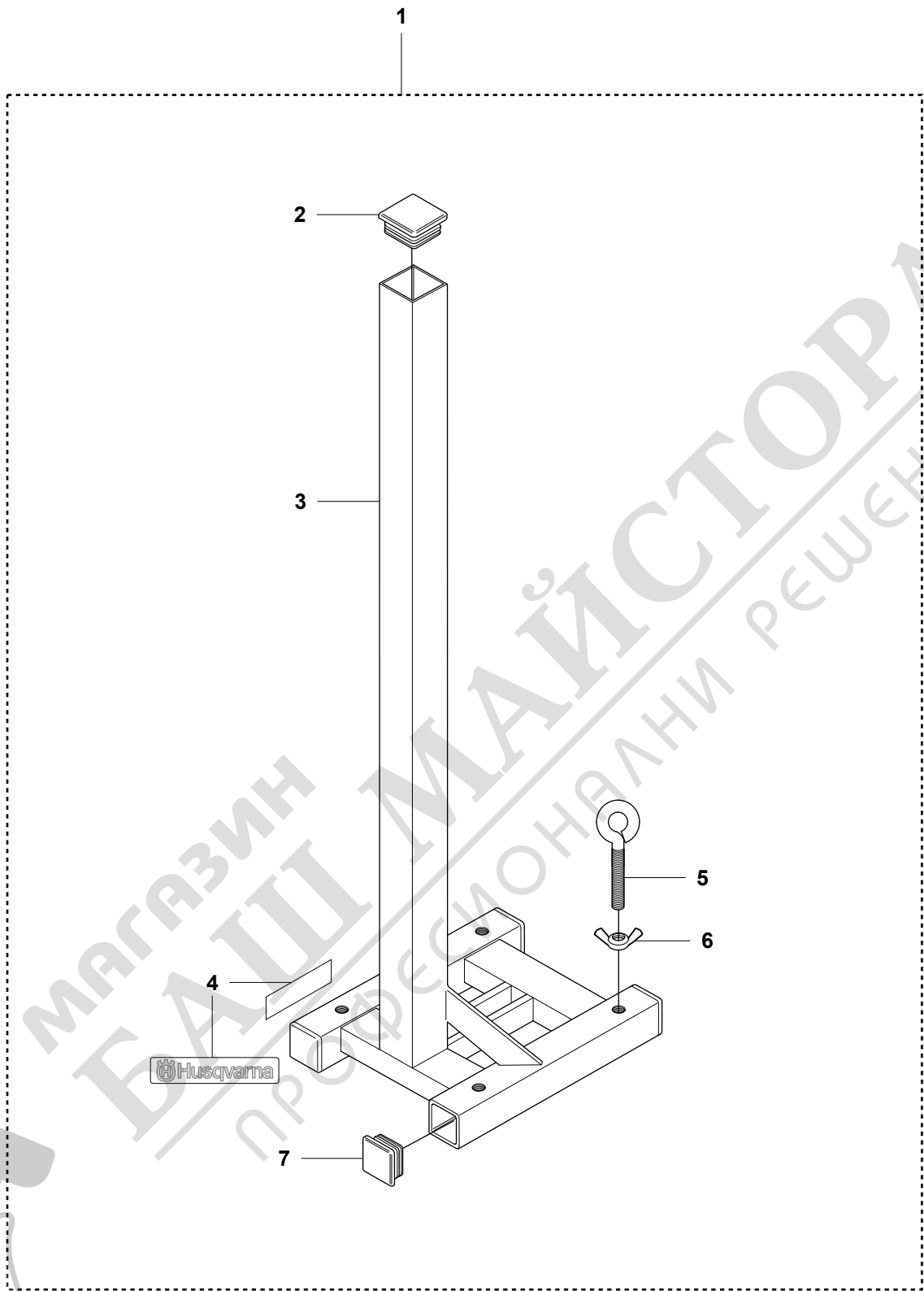

МАГАЗИН МАЙСТОРА
БАЗИШ МАЙСТОРА
ПРОФЕСИОНАЛНИ РЕШЕНИЯ

Page B
DMS 160

Pos.	Part No.	Description	Quantity	Notes
1	506 40 79-14	BASE PLATE DMS160A ASSY	1	Incl. 2-7
2	531 14 06-20	PLUG	1	
3	504 03 04-04	BASE PLATE DMS160A	1	
4	504 02 10-01	DECAL	1	
5	531 14 08-24	SCREW	4	
6	544 45 97-01	WING NUT	4	
7	531 14 08-22	PLUG	4	

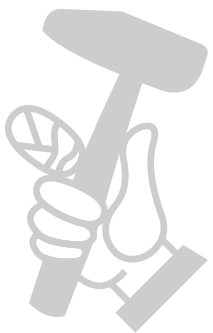

МАГАЗИН
БАШ МАЙСТОРА
ПРОФЕСИОНАЛНИ РЕШЕНИЯ

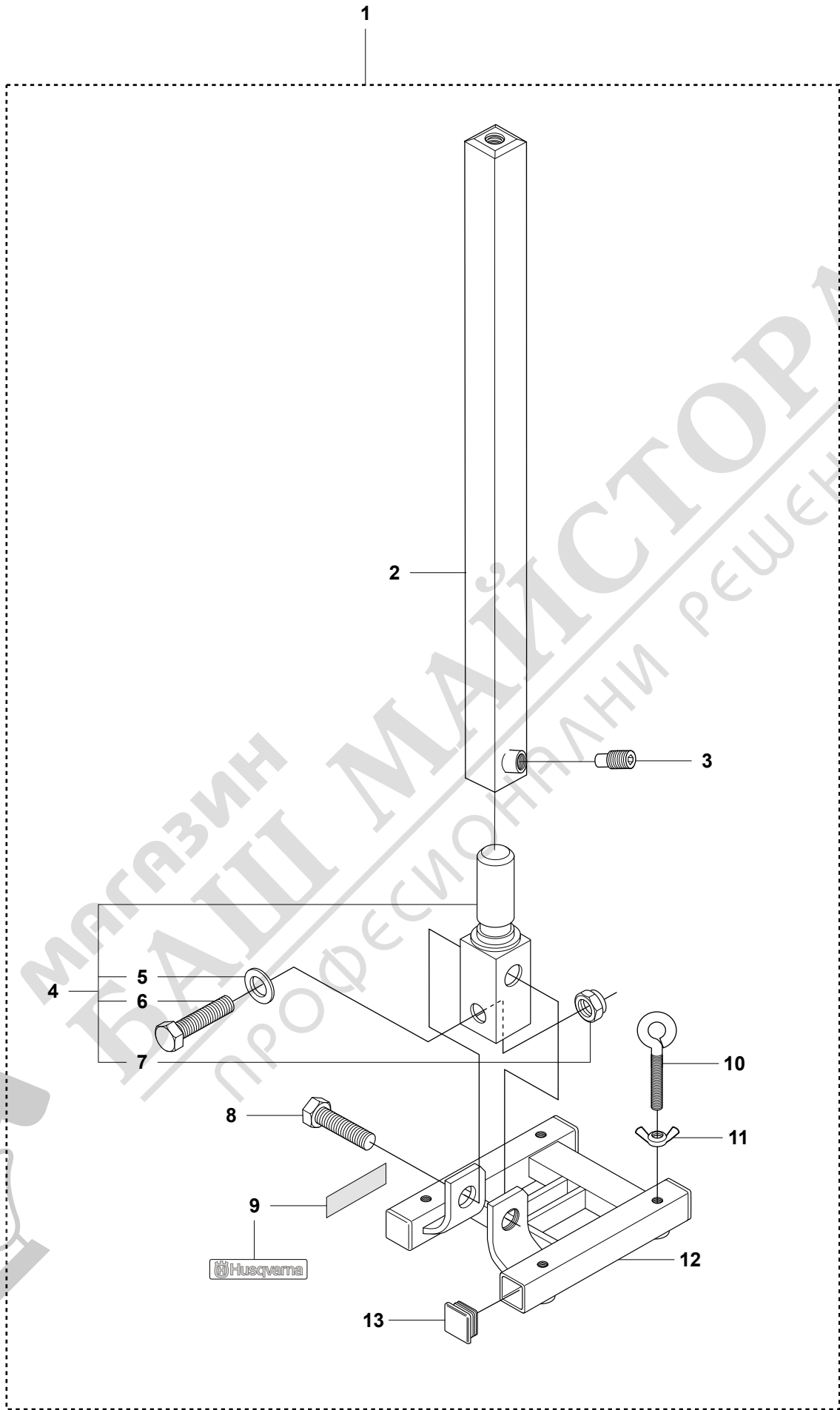

Page C
DMS 160

Pos.	Part No.	Description	Quantity	Notes
1	506 40 79-15	BASE PLATE DMS160AT ASSY	1	Incl. 2-4, 8-13
2	506 40 11-02	DRILL RACK DMS	1	
3	531 14 07-92	SCREW	1	
4	506 40 22-02	RETAINER CPL	1	
5	531 14 07-22	WASHER	1	
6	531 14 08-20	SCREW	1	
7	531 14 07-57	NUT	1	
8	531 14 08-21	SCREW	1	
9	504 02 10-01	DECAL	1	
10	531 14 08-24	SCREW	4	
11	544 45 97-01	WING NUT	4	
12	504 03 04-05	BASE PLATE DMS160AT	1	
13	531 14 08-22	PLUG	4	

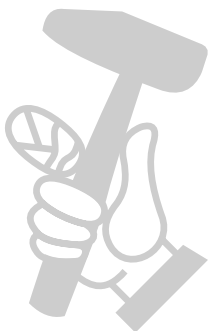

МАГАЗИН
БАШ МАЙСТОРА
ПРОФЕСІОНАЛНИ РЕШЕННЯ

D DMS 160

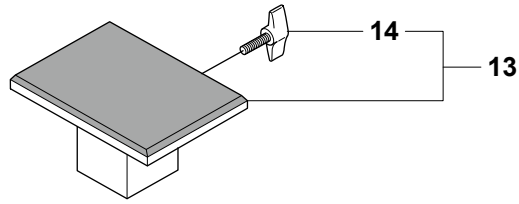

1

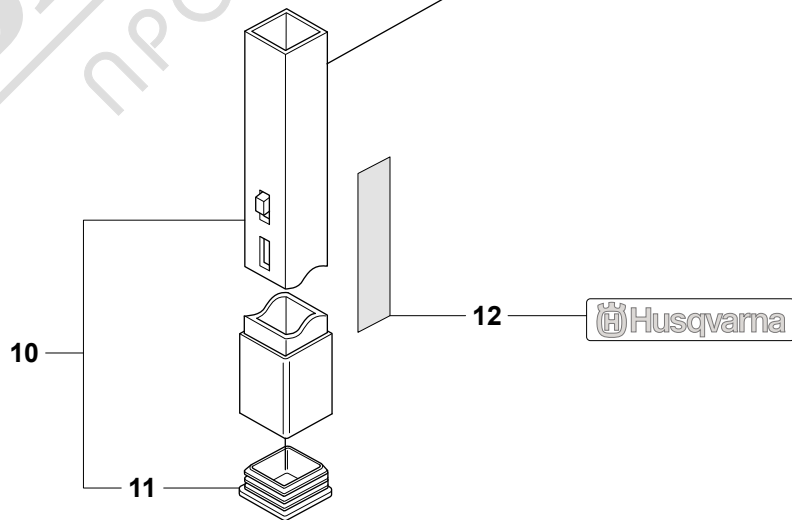
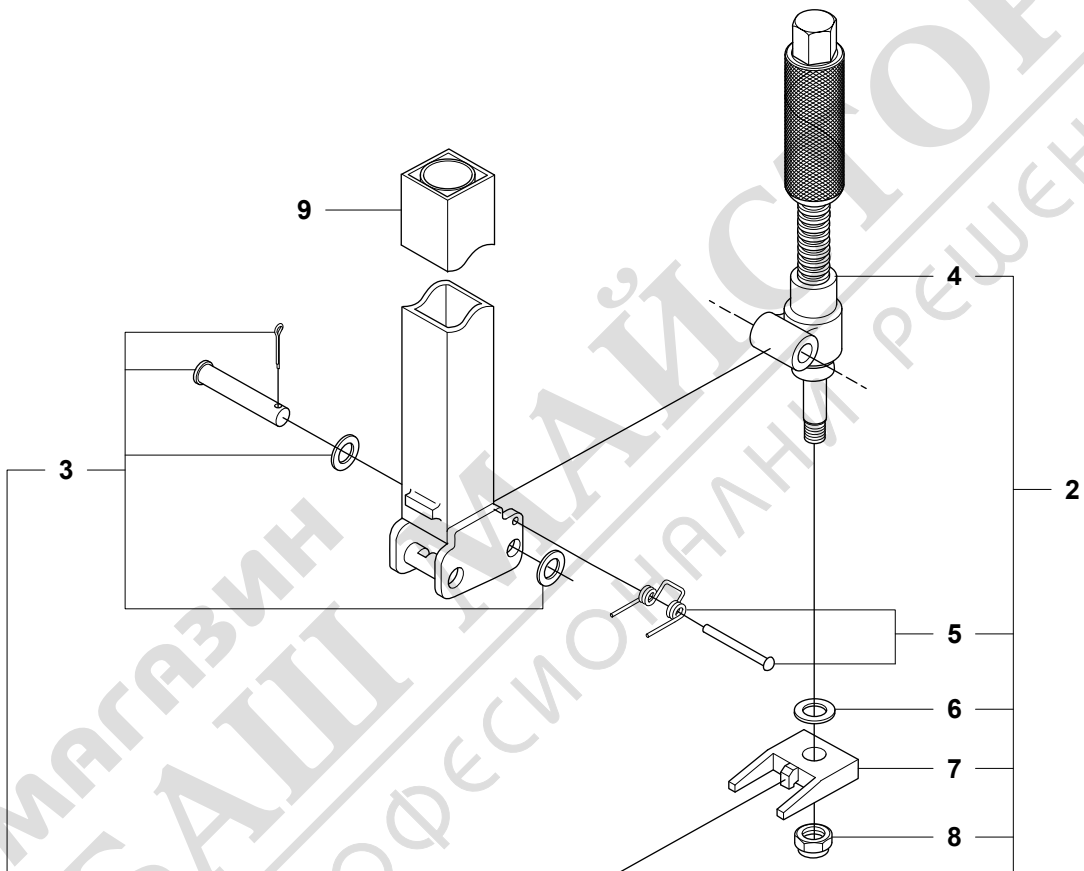

Page D
DMS 160

Pos.	Part No.	Description	Quantity	Notes
1	506 40 83-06	EXPANDABLE COLUMN ASSY	1	Incl. 2, 9, 10, 12
2	506 40 81-06	ADJUSTER CPL	1	Incl. 3-8
3	506 40 14-03	BOLT KIT	1	
4	506 40 81-08	ADJUSTER	1	
5	506 40 14-04	BOLT KIT	1	
6	531 14 06-13	WASHER	1	
7	531 14 07-80	FORK	1	
8	531 14 06-14	NUT	1	
9	531 14 08-13	PIPE OUTER	1	
10	506 40 05-02	PIPE INNER CPL	1	Incl. 11
11	531 14 07-72	PLUG	1	
12	504 02 10-02	DECAL	1	
13	506 40 84-02	TOP SUPPORT CPL	1	Incl. 14
14	531 14 06-02	WING SCREW	1	

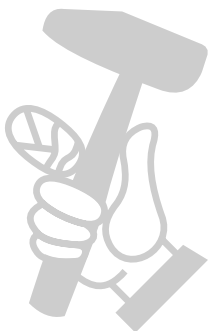

МАГАЗИН
БАШ МАЙСТОР
ПРОФЕСІОНАЛНИ РЕШЕННЯ

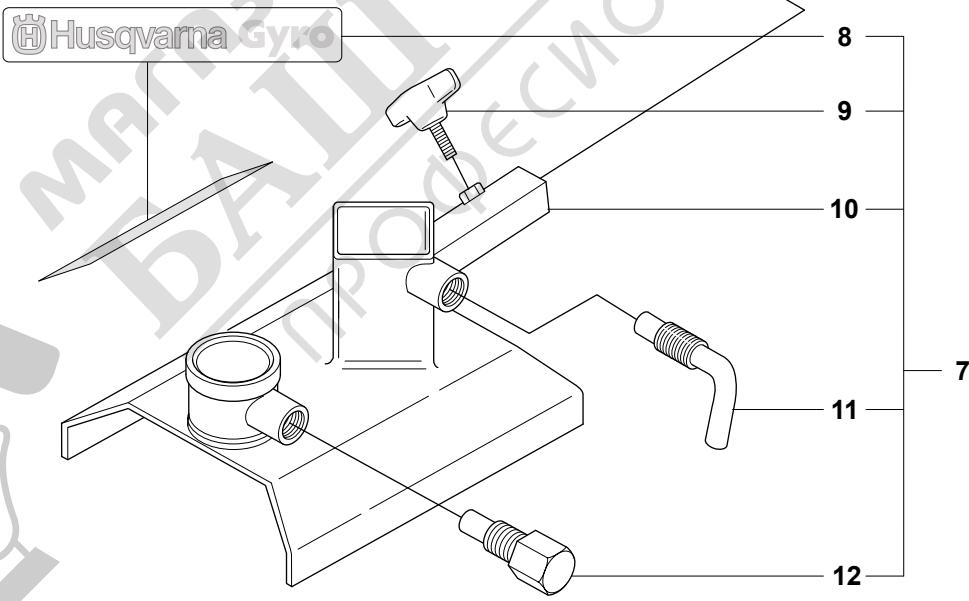
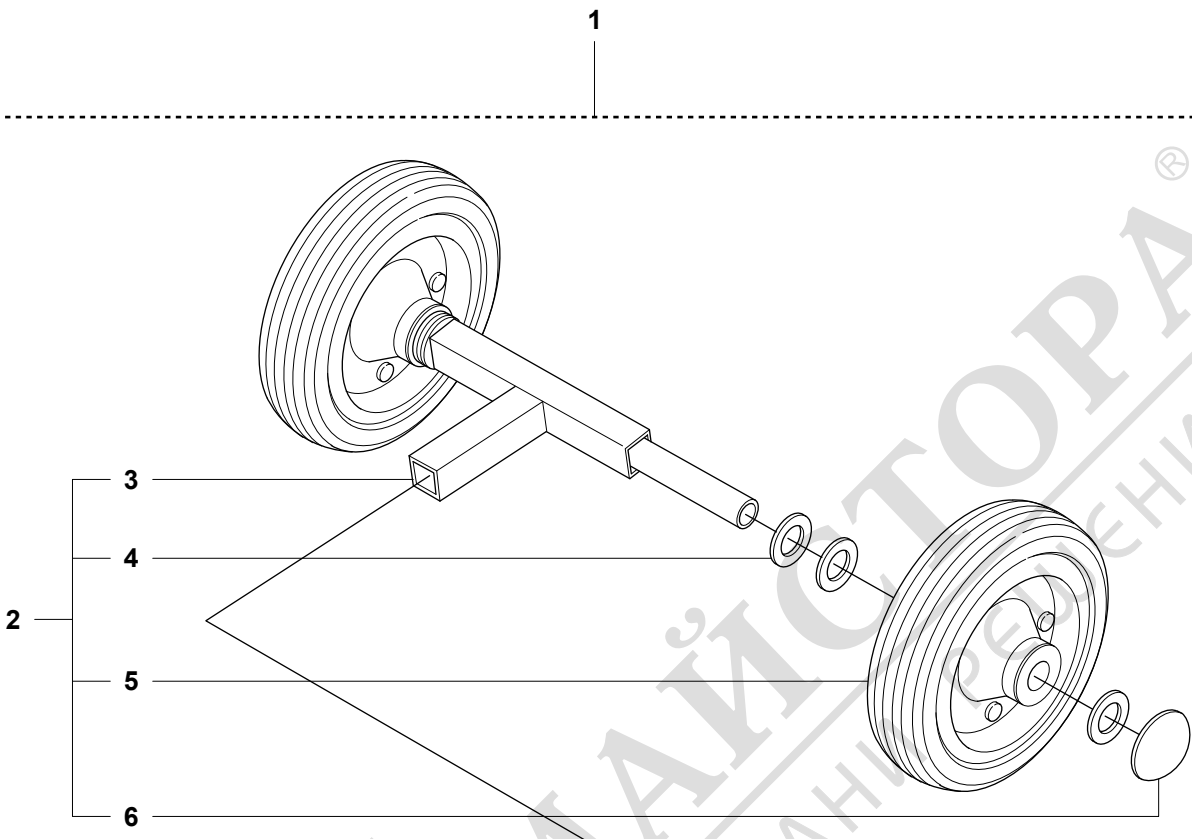

Page E
DMS 160

Pos.	Part No.	Description	Quantity	Notes
1	506 40 80-11	BASE PLATE 40T ASSY	1	Incl. 2, 7
2	506 40 76-11	SHAFT HOLDER WITH WHEEL	1	Incl. 3-6
3	504 02 06-04	SHAFT HOLDER CPL	1	
4	531 14 06-27	WASHER	6	
5	531 14 07-28	WHEEL	2	
6	531 14 07-30	COVER PLATE	2	
7	506 40 79-04	BASE PLATE 40T CPL	1	Incl. 8-12
8	504 02 10-04	DECAL	1	
9	531 14 06-02	WING SCREW	1	
10	531 14 07-74	BASE PLATE 40T	1	
11	531 14 06-43	KNOB	1	
12	531 14 06-19	SCREW	1	

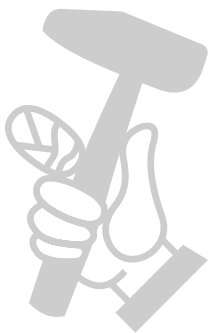

МАГАЗИН
БАШ МАЙСТОРА
ПРОФЕСІОНАЛНИ РЕШЕННЯ

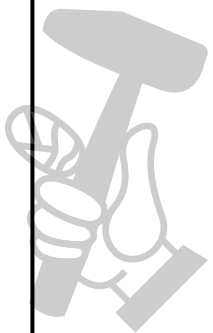
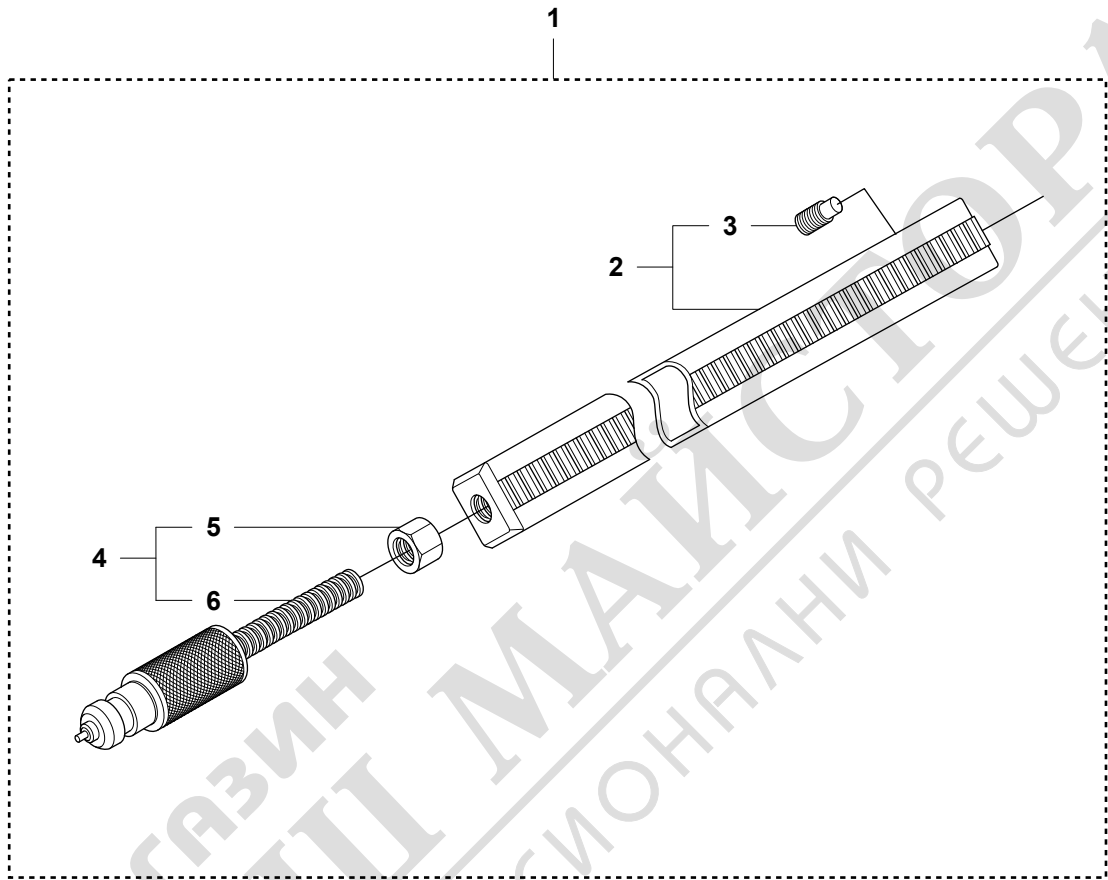

МАГАЗИН
БАШ МАЙСТРА
ПРОФЕСІОНАЛНИ РЕШЕННЯ

Page F
DMS 160

Pos.	Part No.	Description	Quantity	Notes
1	506 40 88-06	DRILL RACK DMS ASSY	1	Incl. 2, 4
2	506 40 11-02	DRILL RACK DMS	1	Incl. 3
3	531 14 07-92	SCREW	1	
4	506 40 06-06	ADJUSTMENT SCREW CPL	1	Incl. 5, 6
5	531 14 06-44	NUT	1	
6	506 40 06-08	ADJUSTMENT SCREW	1	

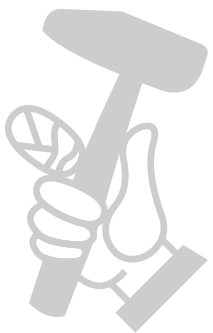

МАГАЗИН
БАШ МАЙСТОРА
ПРОФЕСІОНАЛНИ РЕШЕННЯ

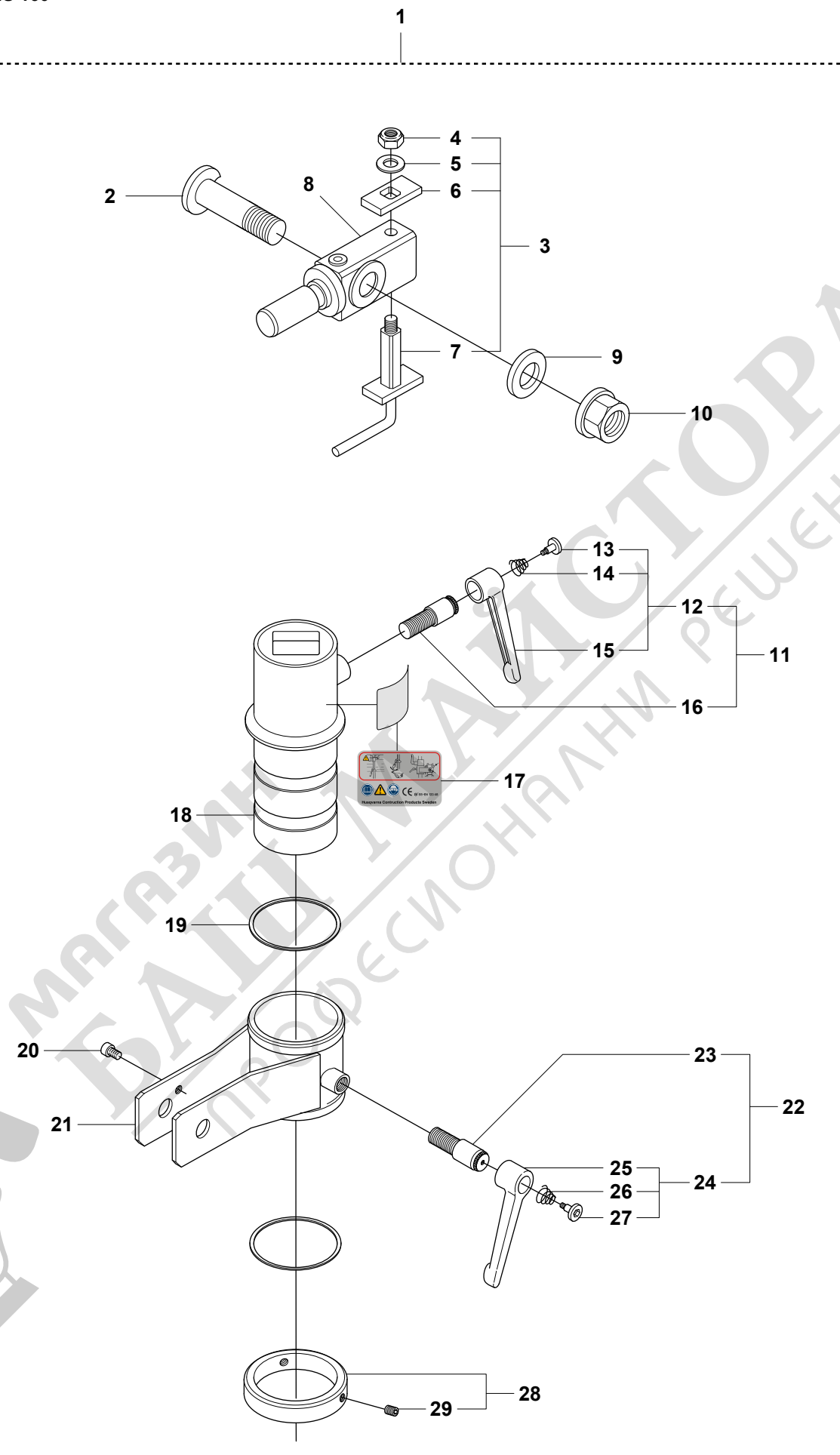

Page G
DMS 160

Pos.	Part No.	Description	Quantity	Notes
1	506 40 91-05	GYRO UNIT 40 ASSY	1	Incl. 2, 3, 8-11, 17-22, 28
2	531 14 07-90	SHAFT	1	
3	506 40 16-02	HANDLE CPL	1	Incl. 4-7
4	531 14 06-00	NUT	1	
5	531 14 07-22	WASHER	1	
6	531 14 07-75	WASHER	1	
7	531 14 07-89	HANDLE	1	
8	544 34 97-02	RETAINER	1	
9	531 14 07-87	WASHER	1	
10	501 38 01-01	NUT	1	
11	506 40 77-13	ADJUSTABLE LEVER CPL	1	Incl. 12, 16
12	501 38 46-03	HANDLE CPL	1	Incl. 13-15
13	501 38 60-01	SCREW	1	
14	501 38 47-01	SPRING	1	
15	504 01 81-01	HANDLE	1	
16	544 23 56-02	SCREW CPL	1	
17	544 12 85-01	DECAL	1	
18	504 02 31-01	SLEEVE INNER	1	
19	531 14 07-99	WASHER	1	
20	531 14 08-00	SCREW	1	
21	504 02 33-01	RETAINER	1	
22	506 40 77-13	ADJUSTABLE LEVER CPL	1	Incl. 23, 24
23	544 23 56-02	SCREW CPL	1	
24	501 38 46-03	HANDLE CPL	1	Incl. 25-27
25	504 01 81-01	HANDLE	1	
26	501 38 47-01	SPRING	1	
27	501 38 60-01	SCREW	1	
28	506 40 18-02	RETAINING RING CPL	1	Incl. 29
29	531 14 06-70	SCREW	2	

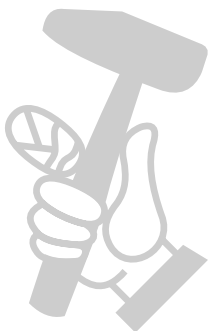

МАГАЗИН МАШИНОСТРОИТЕЛЬНОЙ ТЕХНИКИ
БАШ
 ПРОФЕССИОНАЛЬНАЯ ПЕЧЕНЬ

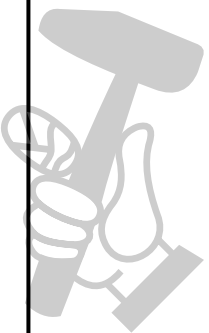
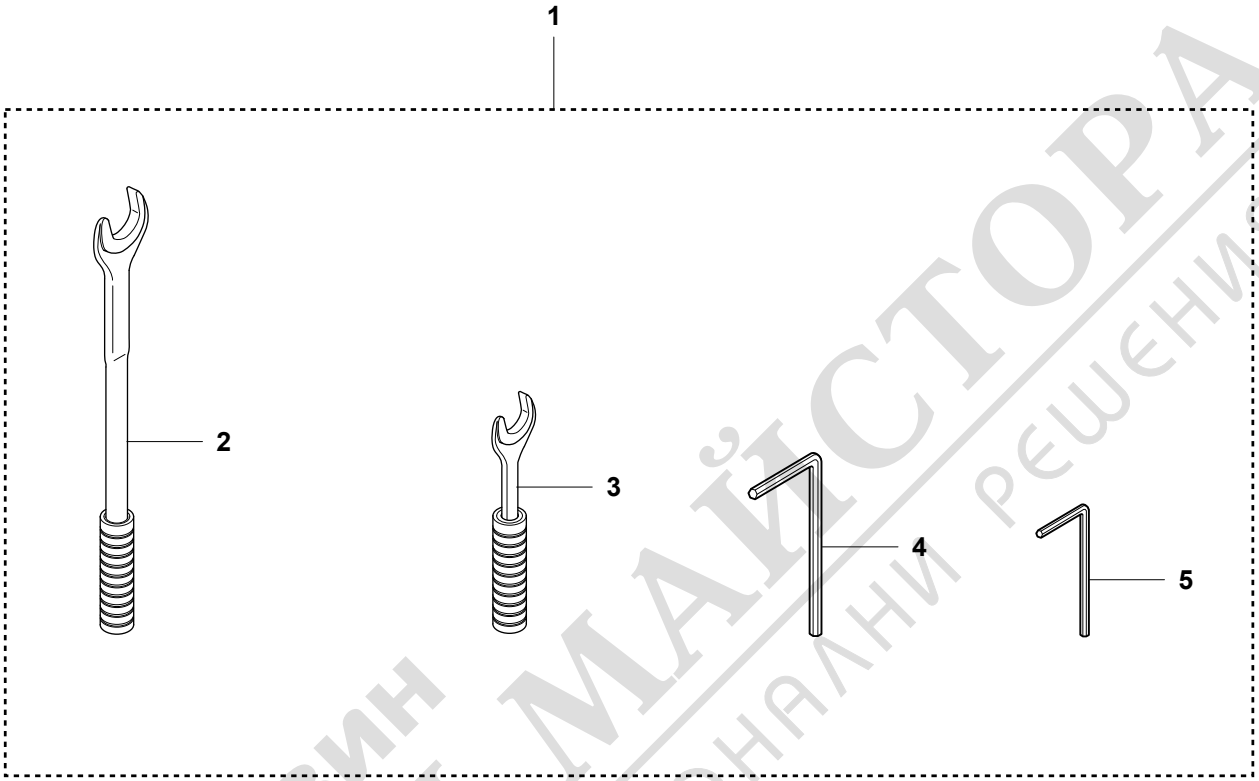

МАГАЗИН
БАШ МАЙСТОРА®
ПРОФЕСІОНАЛНИ РЕШЕННЯ

Page H
DMS 160

Pos.	Part No.	Description	Quantity	Notes
1	506 40 86-03	TOOL KIT	1	Incl. 2-5
2	544 22 27-01	SPANNER 30MM	1	
3	544 22 27-02	SPANNER 24MM	1	
4	531 14 07-62	L ALLEN KEY 8MM	1	
5	544 27 98-01	L ALLEN KEY 6MM	1	

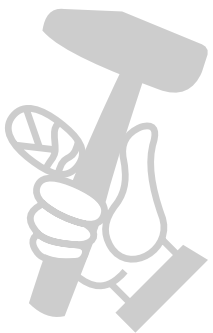

МАГАЗИН
БАШ МАЙСТОРА
ПРОФЕСИОНАЛНИ РЕШЕНИЯ

J

DMS 160

1

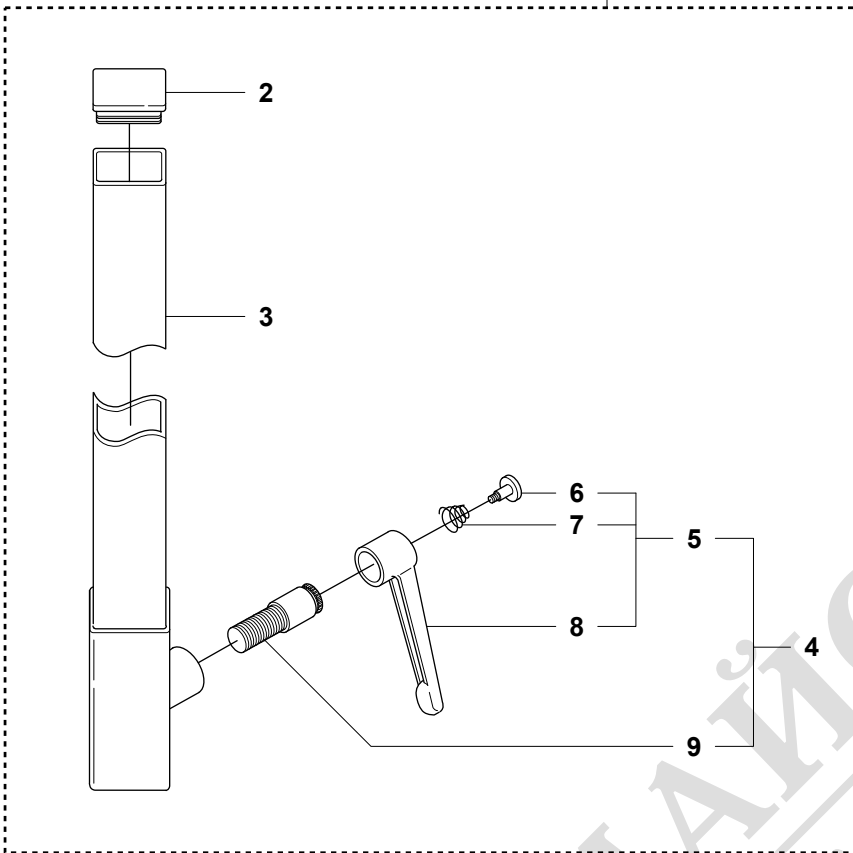

10

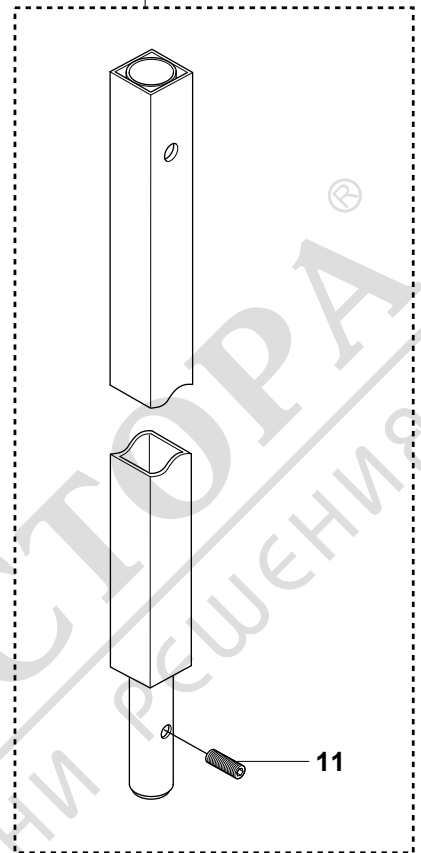

12

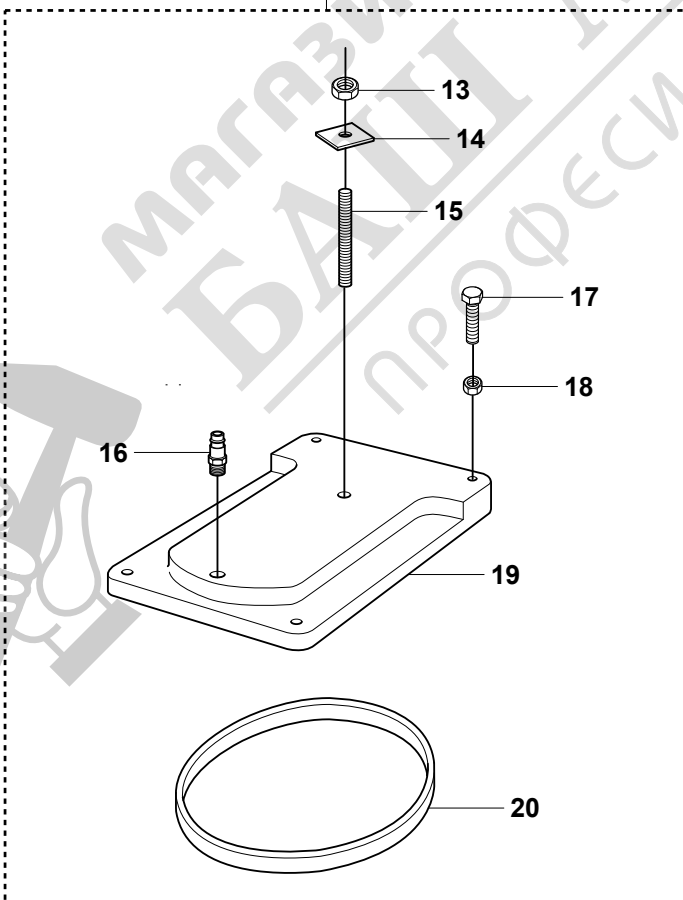

21

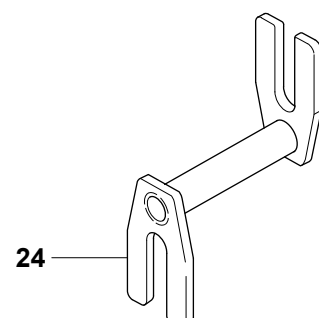
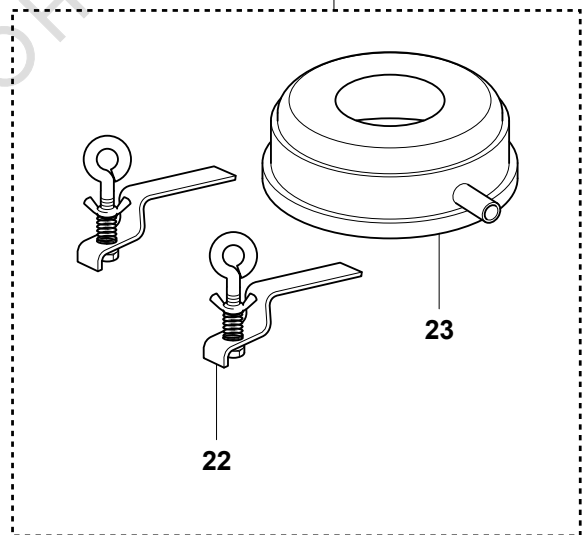

24

Page J
DMS 160

Pos.	Part No.	Description	Quantity	Notes
1	506 40 85-06	EXT. POLE OUTER ASSY	1	Incl. 2-4
2	531 14 06-20	PLUG	1	
3	531 14 08-29	EXT. POLE OUTER	1	
4	506 40 77-13	ADJUSTABLE LEVER CPL	1	Incl. 5, 9
5	501 38 46-03	ADJUSTABLE LEVER	1	Incl. 6-8
6	501 38 60-01	SCREW	1	
7	501 38 47-01	SPRING	1	
8	504 01 81-01	HANDLE	1	
9	544 23 56-02	SCREW CPL	1	
10	506 40 05-04	EXT. POLE INNER ASSY	1	Incl. 11
11	531 14 08-31	SCREW	1	
12	544 45 84-01	VACUUM PLATE 300 ASSY	1	Incl. 13-20
13	544 96 44-01	NUT	1	
14	544 45 89-01	WASHER	1	
15	544 45 88-01	SCREW	1	
16	544 45 87-01	VACUUM INLET CONNECT	1	
17	502 30 01-01	ADJUSTING SCREW	4	
18	531 14 08-25	NUT	4	
19	544 45 85-01	VACUUM PLATE 300	1	
20	544 45 86-01	SEALING RING	1	
21	544 45 93-01	WATER COLLECTOR ASSY	1	Incl. 22, 23
22	544 46 02-01	SCREW KIT	2	
23	544 46 01-01	WATER COLLECTOR	1	
24	531 14 06-46	ANCHOR BOLT HOLDER	1	

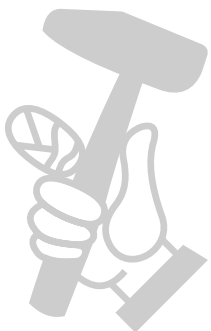

МАГАЗИН МАШИН И ИНСТРУМЕНТОВ
БАШ МАШИНА
ПРОФЕССИОНАЛЬНЫЕ РЕУЧКИ