

STIHL USG

Instruction Manual
Owner's Manual

Assembling
Safety Precautions
Operating Instructions
Maintenance

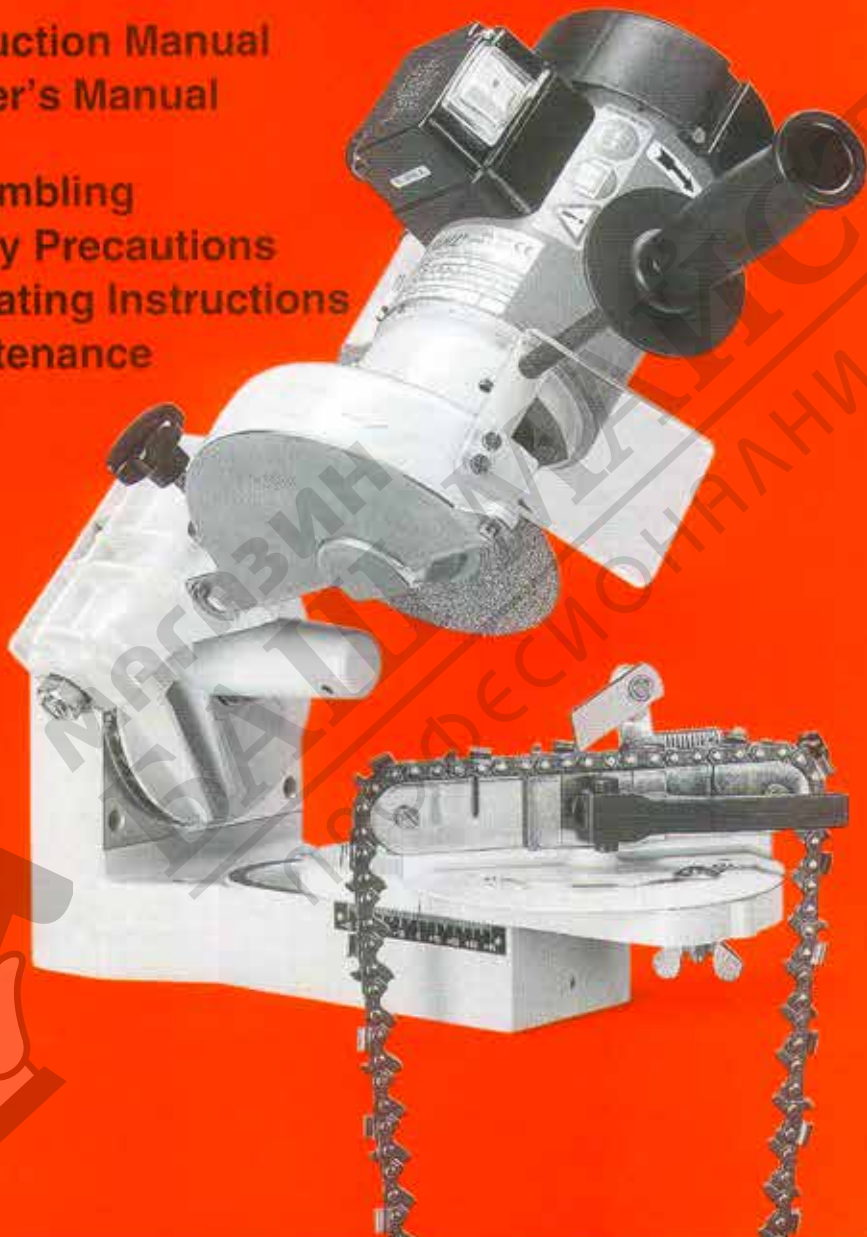

Warning:
Always follow safety precautions in
Owner's Manual - improper use
can cause serious injury!

Contents

Guide to Using this Manual	2
Safety Precautions	3
Applications	4
Mounting the Tool	4
Selecting the Grinding Wheel	6
Mounting the Grinding Wheel	7
Test Run	8
Dressing the Grinding Wheel	8
Scales	8
Setup for Sharpening Saw Chain	9
Sharpening Procedure	15
Lowering Depth Gauges	17
Setup for Sharpening Hedge Trimmer Blades	19
Sharpening Hedge Trimmer Blades	24
Preparations for Sharpening Circular Saw Blade	27
Sharpening Circular Saw Blade	31
Maintenance Chart	32
Minimize Wear and Avoid Damage	33
Main Parts of Sharpener	34
Specifications	35
Special Accessories	35
Maintenance and Repairs	35
Certificate of Conformity	36
Quality Certification	36

Dear Customer,

Thank you for choosing a quality engineered STIHL product.

This machine has been built using modern production techniques and comprehensive quality assurance. Every effort has been made to ensure your satisfaction and troublefree use of the machine.

Please contact your dealer or our sales company if you have any queries concerning your machine.



Hans Peter Stihl

CE

Guide to Using this Manual

Pictograms

All the pictograms attached to the machine are shown and explained in this manual.

The operating and handling instructions are supported by illustrations.

Symbols in text

The individual steps or procedures described in the manual may be marked in different ways:

- Step or procedure without direct reference to an illustration.

Description of step or procedure that refers directly to the illustration and contains item numbers that appear in the illustration.

Example:

Loosen the screw (1)
Lever (2) ...

In addition to the operating instructions, this manual may contain paragraphs that require your special attention. Such paragraphs are marked with the symbols described below:

 Warning where there is a risk of an accident or personal injury or serious damage to property.

 Caution where there is a risk of damaging the machine or individual components.

 Note or hint which is not essential for using the machine, but may improve the operator's understanding of the situation and result in better use of the machine.

 Note or hint on correct procedure in order to avoid damage to the environment.

* Equipment and features

This instruction manual refers to several models with different features. Components that are not installed in all models and related applications are marked with an asterisk (*). Such components may be available as special accessories from your STIHL dealer.

Engineering improvements

STIHL's philosophy is to continually improve all of its products. As a result, engineering changes and improvements are made from time to time. If the operating characteristics or the appearance of your machine differ from those described in this manual, please contact your STIHL dealer for assistance.

Therefore, we cannot be responsible for changes, modifications or improvements not covered in this manual.

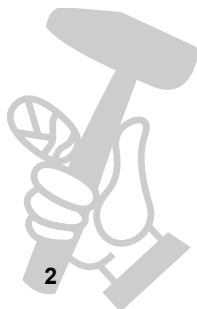

Safety Precautions



Additional safety precautions have to be observed when operating the universal sharpener.



It is important that you read and understand the owner's manual before using your tool for the first time. Keep it in a safe place for later reference.

Non-observance of the following safety precautions may cause serious or even fatal injury.

Always observe local safety regulations, standards and ordinances.

If you have never used this sharpener model before:

Have your dealer or a trained expert show you how to operate it properly and safely.

Minors should never be allowed to use an electric sharpener.

Keep children, bystanders and animals well clear of the work area.

Only use the grinding wheels supplied by STIHL or expressly approved by STIHL for use with your specific model.

Do not use any other grinding wheels since they will increase the risk of injury.

Switch on the motor only if its operating voltage agrees with the voltage of your power supply.

Clothing and Equipment

Wear proper protective clothing and equipment.

The grinding dust produced when using this sharpener may cause health problems. Always use a dust **extractor** or wear a suitable **respirator**.

The sparks created during sharpening may cause eye injuries.



Always wear **safety glasses**.

Clothing must be sturdy and snug-fitting, but allow complete freedom of movement.

Wear overalls – avoid loose-fitting jackets.



Wear steel-toed **safety boots** with non-slip soles.



Wear **heavy-duty, non-slip gloves**, preferably made of leather.

Before Starting Work

Check that your sharpener is properly assembled and in good condition. Do not operate your sharpener with a damaged connecting cord or grinding wheel.

Maintenance and Repairs

Always disconnect the unit from the power supply before carrying out any maintenance work. Only perform the adjustments and maintenance operations described in this manual.

All other maintenance and repairs should be carried out by your STIHL dealer.

Only use original STIHL replacement parts.

In the interests of your own safety, never modify your electric sharpener in any way.

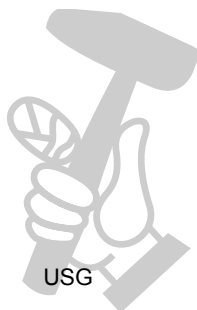

Applications

The STIHL USG sharpens all STIHL Oilomatic saw chains, hedge trimmer blades and circular saw blades.

Optional swivelling tool rests are required for sharpening scratcher tooth chain, hedge trimmer blades and circular saw blades.

Mounting the Tool

The unit may be mounted on a wall or workbench.

If you mount the unit on a bench, note that the unit must overhang the bench by at least 120 mm.

If you use the special attachment for hedge trimmer blades:

If you mount the unit on a wall, note that a clearance of at least 450 mm is required between the wall and the unit for sharpening hedge trimmer blades. Recommendation: Mount the unit on a bench for such work.

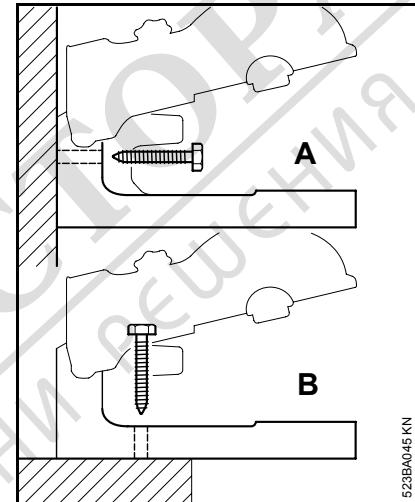

Secure the unit with screws

- A =** For wall mounting, use three suitable 8 mm dia. screws (e.g. 8 mm x 100 mm wood screws, DIN 571-St), 8.4 mm dia. washers and suitable wall plugs (e.g. 10x50 mm plastic wall plugs)
- B =** For bench mounting, use two suitable 8 mm dia. screws (e.g. 8 mm x 100 mm wood screws, DIN 571-St), 8.4 mm dia. washers

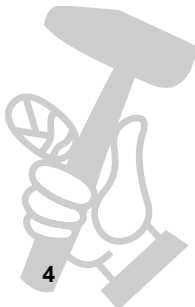

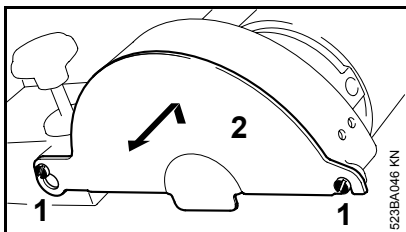

- Loosen the M5x10 screws (1) and then lift and remove the guard plate (2).

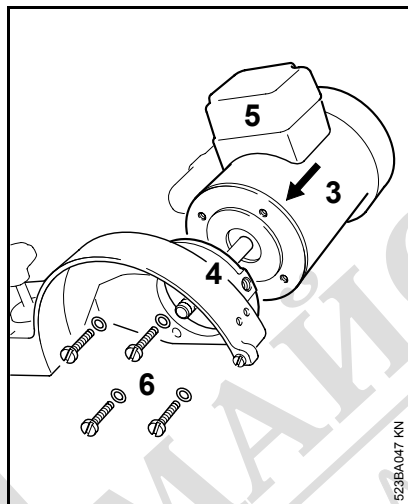

- Fit motor (3) on motor arm (4). The switchbox (5) must face up.
- Insert the four M5x22 pan head screws (6) and tighten them down firmly in a diagonal pattern.

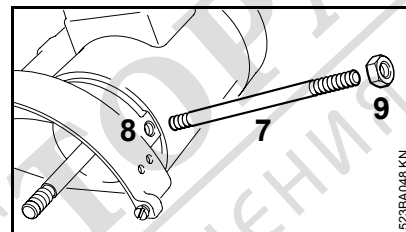

- Screw the short thread of M10x145 stud (7) into the housing bore (8).
- Screw the M10 nut (9) onto the stud as far as stop.

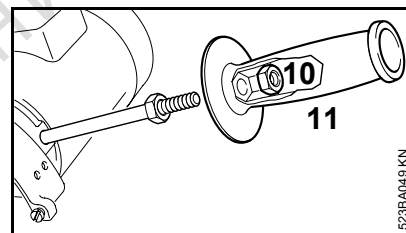

- Place the M10 nut (10) in the hexagon recess in the handle (11) and screw the handle firmly into position.

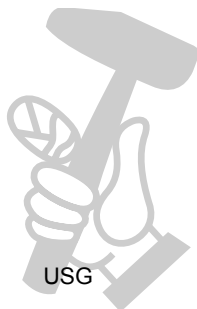

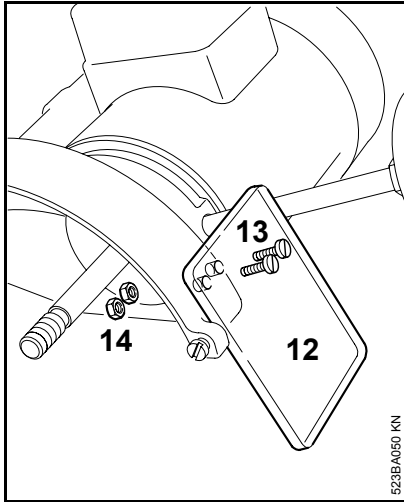

- Place the eye shield (12) against the guard and line up the holes.
- Insert the M4x12 screws (13) in the holes and fit the nuts (14).
- Tighten down the screws firmly.
- Refit the guard plate.

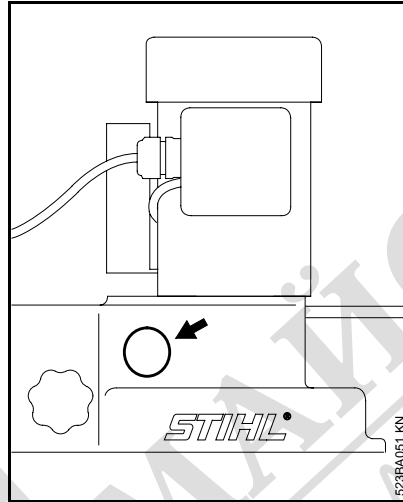

Work Light (Special Accessory)

- Use a punch to pierce the casting skin.
- Clean up the edges with a round file.
- Position lamp socket in opening from outside and secure it with the screw ring.

Selecting the Grinding Wheel

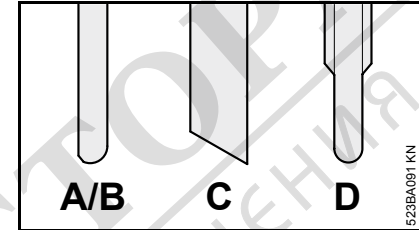

- A** = Grinding wheel 5203 750 7010 (2.4 mm radius at one side)
- B** = Grinding wheel 5203 750 7013 (2.0 mm radius at one side)
- C** = Grinding wheel 5203 750 7015
- D** = Diamond grinding wheel 5203 757 0901

Grinding wheel Application

Grinding wheel	Application
A	<ul style="list-style-type: none"> ● Circular saw blades ● Hedge trimmer blades ● Oilomatic chain, pitch: 3/8", 0.404", 0.325"
B	<ul style="list-style-type: none"> ● Oilomatic chain, pitch: 1/4", 3/8" P, 3/8" PMN
C	<ul style="list-style-type: none"> ● Oilomatic chain, depth gauges
D	<p>Carbide:</p> <ul style="list-style-type: none"> ● Oilomatic chain Rapid Duro Rapid Duro S ● Carbide tipped circular saw blade

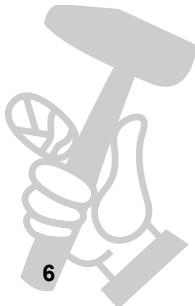

Mounting the Grinding Wheel

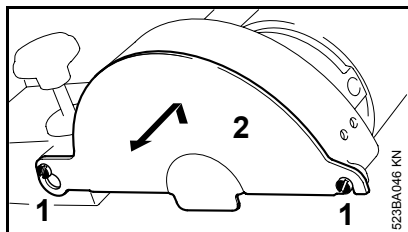

! Always check condition of grinding wheels by performing ringing test before mounting. Never use damaged grinding wheels.

- Loosen the M5x10 screws (1), then lift and remove the guard plate (2).

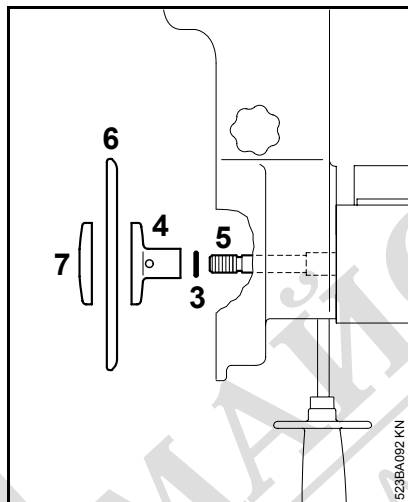

- Fit the O-ring (3) in the groove in the spacer (4) and then push the spacer onto the motor shaft (5) (spacer flange must face away from motor).
- Fit the required grinding wheel (6).
- Fit the thrust washer (7) on the shaft with its raised side facing away from motor.

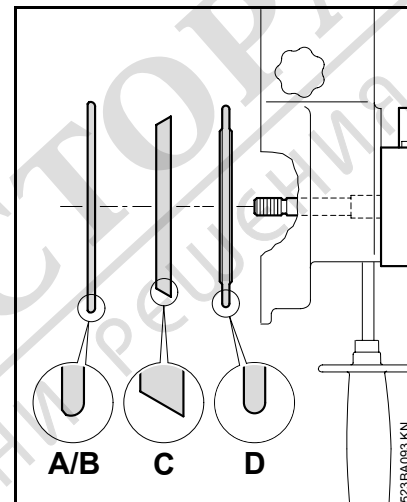

Grinding wheel	Installed position
A/B	Radius facing motor (pointing to the right)
C	Large outside diameter facing motor (pointing to the right)
D	Either way round

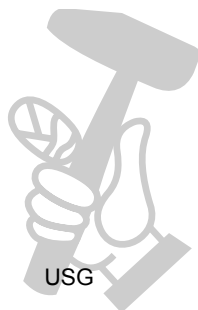

Test Run

Every time you mount a grinding wheel:

- Cordon off the general work area (danger zone).
- Run grinding wheel at maximum permissible speed for at least one minute.

Dressing the Grinding Wheel

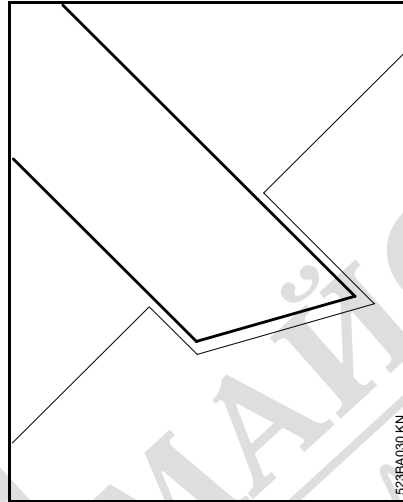

The profile of the grinding wheel is subject to wear.

Switch off the motor.

- Use dressing gauge (special accessory) to check the profile of the grinding wheel.
- Set scale **C** on swivelling tool rest to "0".
- Use dressing stone (special accessory) to correct the profile of the grinding wheel.

Scales

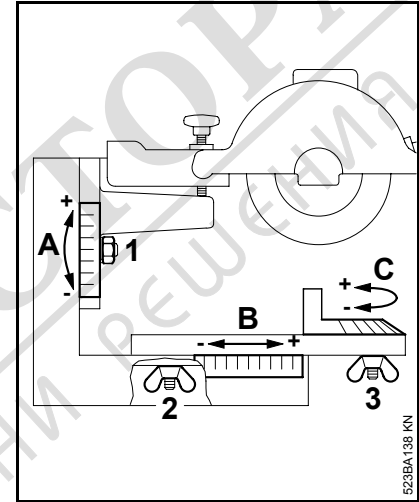

Scale A

- Loosen the nut (1), adjust angle, tighten down the nut firmly.

Scale B

- Loosen the wingnut (2) on the underside of the base, adjust to required value, tighten down the wingnut firmly.

Scale C

- Loosen the wingnut (3), adjust angle, tighten down the wingnut firmly.

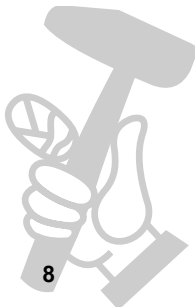

Setup for Sharpening Saw Chain

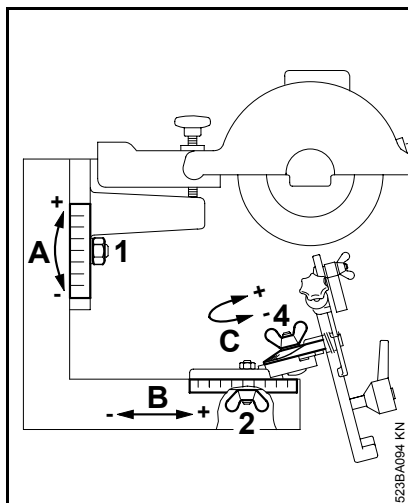

Scale C (attachment for circular saw blades)

- Loosen the wingnut (4), adjust angle, tighten down the wingnut firmly.

⚠ Inspect the chain.

Replace damaged or worn parts of the chain. Grind the new parts back to the shape and size of the other parts.

- Select the grinding wheel – see instruction sheet 0457 716 0000.
- Mount the grinding wheel – see "Mounting the Grinding Wheel".
- Test run the grinding wheel – see "Test Run".
- Check profile of grinding wheel and dress if necessary – see "Dressing the Grinding Wheel".

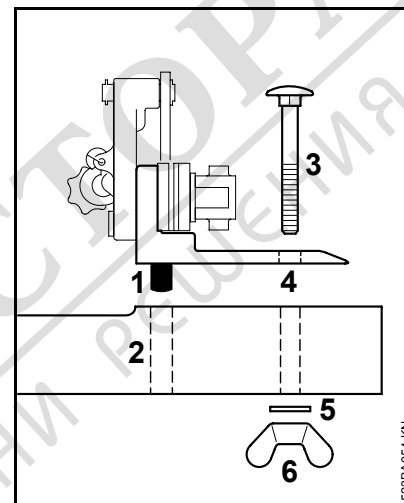

Mounting Attachment for Saw Chain

- Engage pin (1) in hole (2) in base.
- Insert bolt (3) in slot (4).
- Fit the washer (5) and wingnut (6) and tighten down moderately.

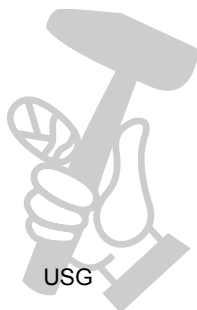

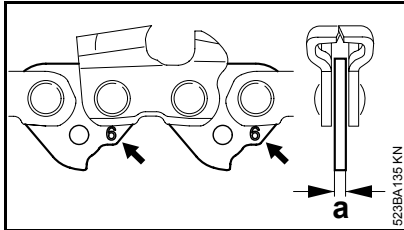

Determining Drive Link Gauge

The clamp must be adjusted to suit the drive link gauge.

Drive link gauge:

- Use slide caliper to measure dimension "a"
- or
- note the digit (arrow)

Digit	Drive link gauge in mm
1	1.1
3	1.3
5	1.5
6	1.6
0	2.0

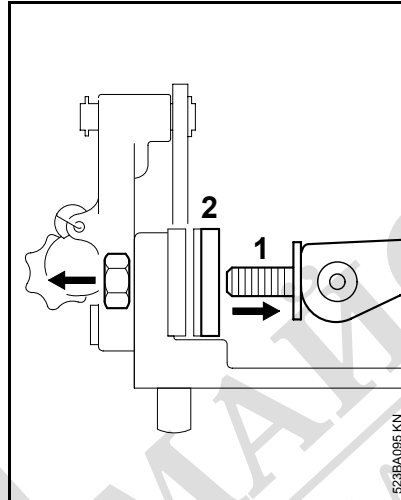

Adjusting the Clamp

- Unscrew the clamping lever (1).
- Remove the thrust plate (2) and nut.

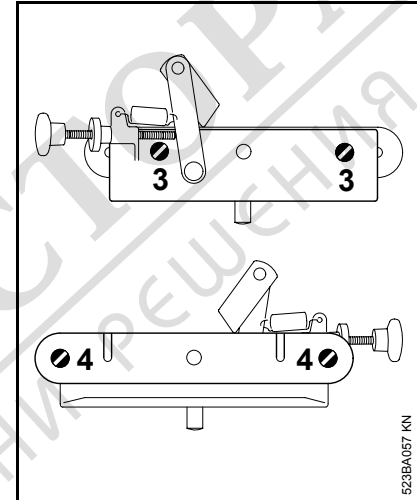

- Take out the screws (3).
- Take out the screws (4).

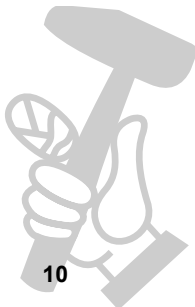

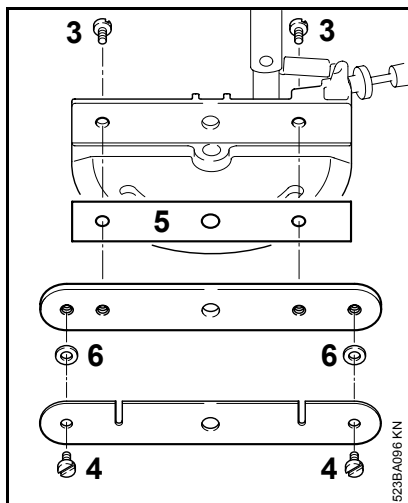

Chain with 1.1/1.3 mm drive link gauge

- Fit the shim (5).
- Fit the screws (3).
- Install a **1.6 mm** washer (6) between the guide rail and clamping rail (at each end).
- Fit the screws (4).

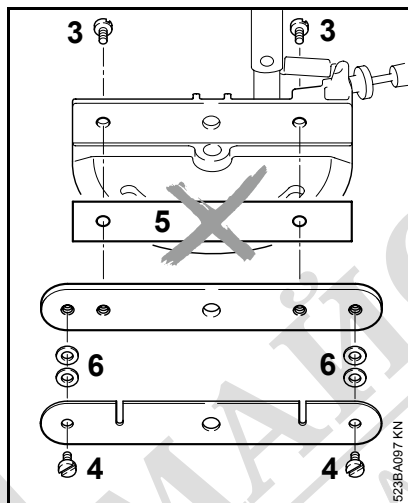

Chain with 1.5/1.6 mm drive link gauge

- Remove the shim (5) (if fitted).
- Fit the screws (3).
- Install **two 0.9 mm** washers (6) between the guide rail and clamping rail (at each end).
- Fit the screws (4).

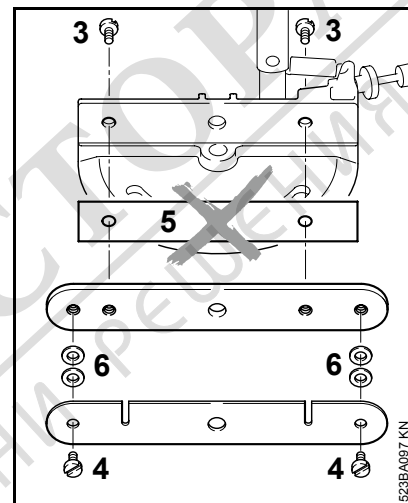

Chain with 2.0 mm drive link gauge

- Remove the shim (5) (if fitted).
- Fit the screws (3).
- Install **one 0.9 mm and one 1.6 mm** washer (6) between the guide rail and clamping rail (at each end).
- Fit the screws (4).

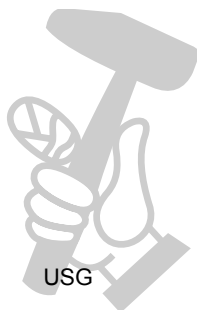

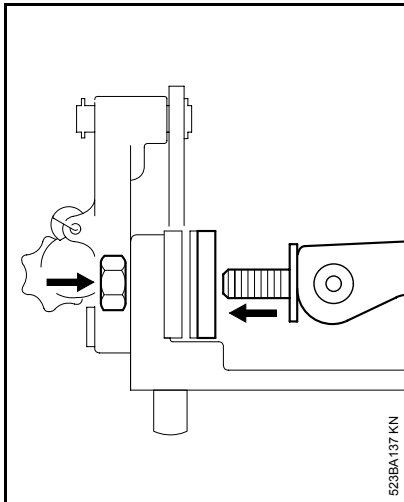

- Fit the clamping lever.

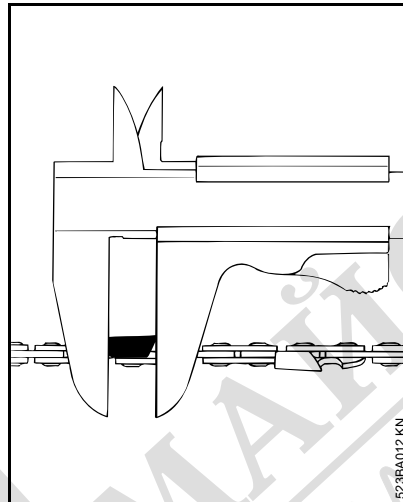

Finding the Master Cutter

The shortest cutter is used as the master cutter.

The master cutter is sharpened first. All other cutters are then ground to the same length as the master cutter.

- Use a slide caliper to find the shortest cutter and mark it, e.g. with chalk.

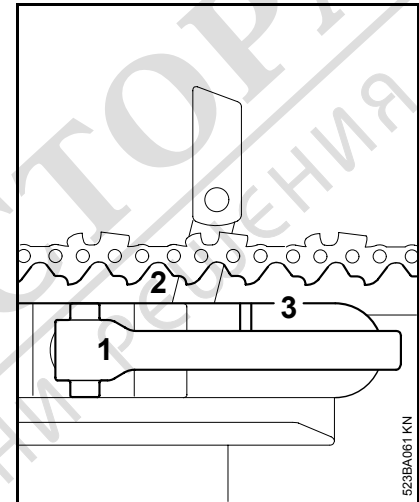

Fitting the Saw Chain

- Release the clamping lever (1).
- Place the chain in position, drive link tangs (2) between the rails (3) – cutting edges must point to the left.

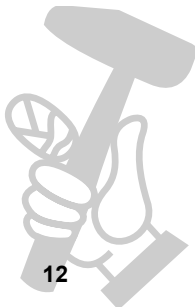

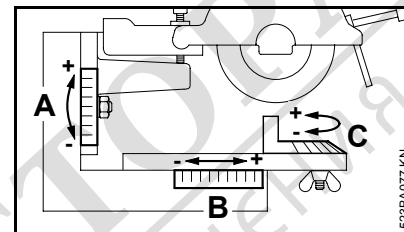
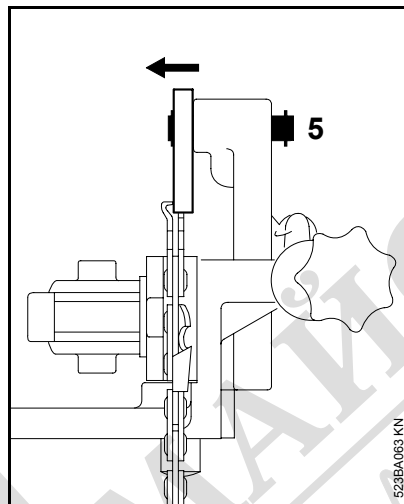
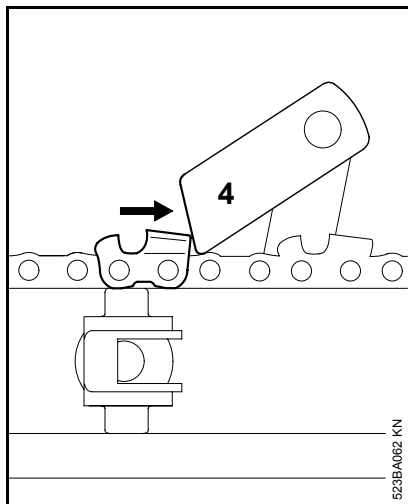

Setting the scales

- Set the scales to the values specified in the instruction sheet 0457 716 0000.

- Pull the master cutter back against the stop (4).
- The pivot pin (5) moves backward and forward so that the stop can be properly located against the back of the cutter.
- To sharpen the **left-hand** row of cutters: Pull the stop in the direction of the arrow.
- To sharpen the **right-hand** row of cutters: Push the stop in the other direction.

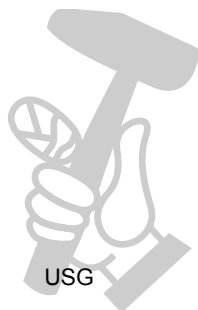

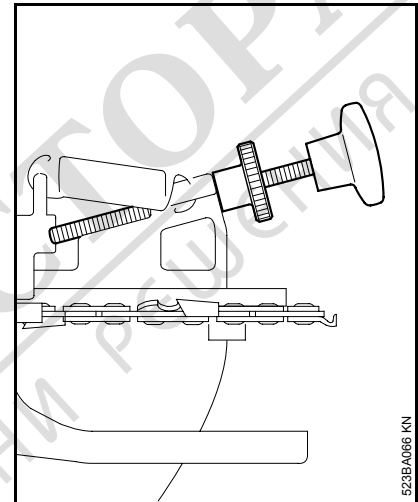
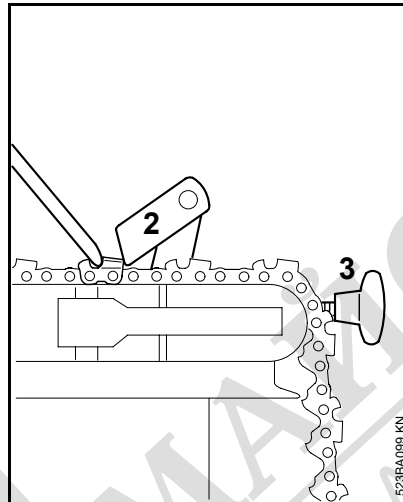
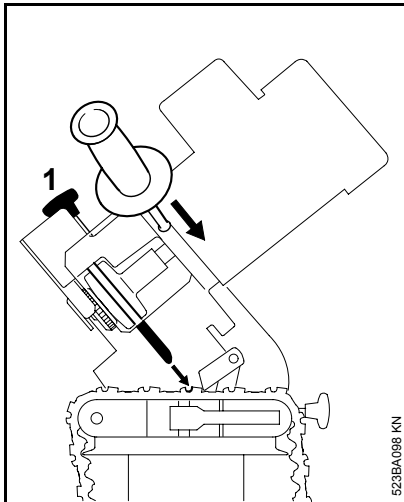

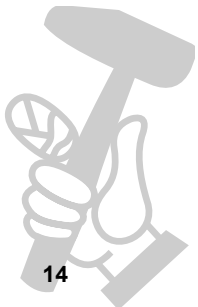

Adjusting Lateral Stop

- Back off the travel limiting screw (1).
- Use the handle to bring the grinding wheel down to the chain.
- Move the stop (2) with the adjusting screw (3) so that the master cutter's side plate butts against the grinding wheel.
- Clamp the chain firmly in position.
- Tighten down the knurled nut on the adjusting screw.

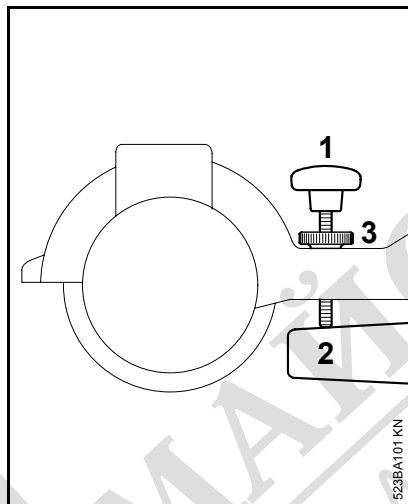
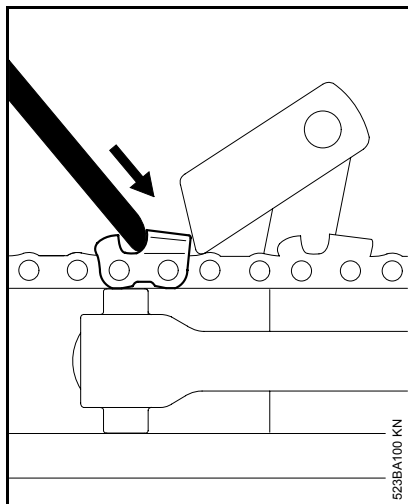

Sharpening Procedure



 Wear safety glasses.

Sharpening the Master Cutter

- Switch on the motor.
- Bring motor arm slowly downward. Check sharpening process. Do not remove too much material.
- If necessary, switch off motor and readjust.
- Sharpen the side plate by applying the wheel several times – do not sharpen in a single pass.
- When result is satisfactory, check the grinding depth.

Adjusting Grinding Depth

- Swing the motor arm down until grinding wheel touches the gullet of the cutter – hold it in this position.
- Screw the travel limiting screw (1) down as far as the stop lug (2).
- Tighten down the knurled nut (3) firmly.
- Swing the motor arm up again.

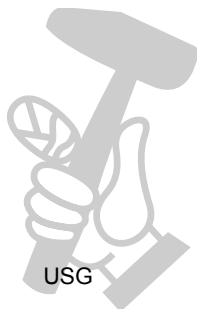

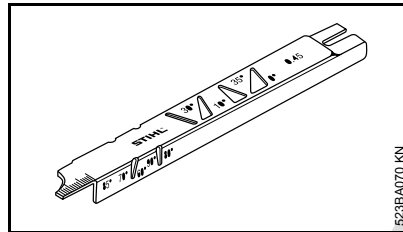
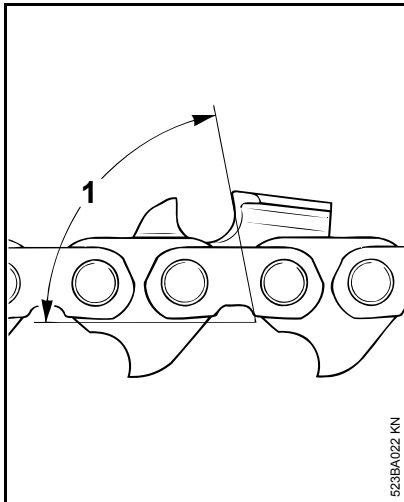

- Check angle with a filing gauge.

If side plate angle is too obtuse (wide):

- Use travel limiting screw to set motor arm lower.
- ⚠ Avoid touching the drive links or tie straps with the grinding wheel. This could cause the chain to break.

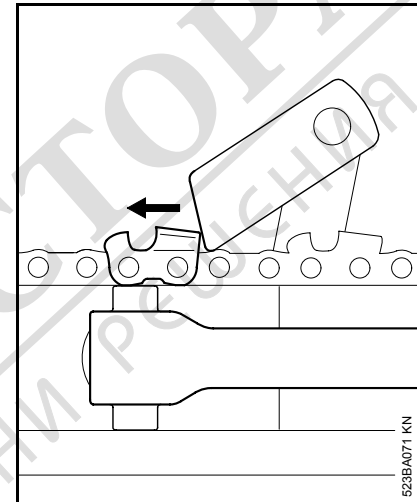

The travel limiting screw must now butt against the stop lug and the side plate angle (1) should be as specified.

If side plate angle is too acute (narrow):

- Use travel limiting screw to set motor arm higher.
- Lock the adjusting and travel limiting screws with their knurled nuts.

Sharpening Row of Cutters

Use the setting for the master cutter to sharpen all the other cutters in the row.

- Release clamping lever. Pull the chain to the left until the stop is behind the next cutter but one.

Chain type	Angle in degrees
Rapid-Standard	85
Rapid-Micro	85
Rapid-Super	60
Picco-Micro	85
Picco-Micro-Mini	85
Rapid-Duro	65
RCX, RMX, PMX	80

Lowering Depth Gauges

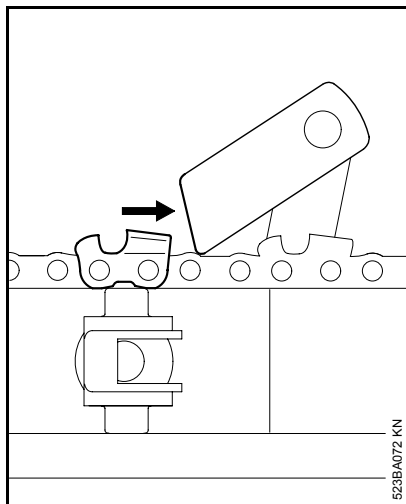

Sharpening the Second Row of Cutters

- Set scale **B** to the same sharpening angle on the other side of the chain.
- Set scale **C** to the specified angle on the other side of the chain.
- Move the stop with the pivot pin – the stop must locate properly against the back of the cutter.
- After sharpening first cutter in the second row, check its length against that of the other row and adjust the stop if necessary.
- Now sharpen the second row of cutters.

- Pull the chain to the right until the back of the cutter butts against the stop.
- Clamp the chain in position.
- Sharpen the side plate.
- Repeat procedure until all side plates on one side have been sharpened.

Checking Depth Gauge Setting

- Select the filing gauge (special accessory) that matches the chain pitch.

Chain pitch		Filing gauge
inch	mm	Part No.
$\frac{1}{4}$	6.35	1110 893 4000
$\frac{3}{8}$ PMN	9.32	0000 893 4000
$\frac{3}{8}$ P	9.32	1110 893 4000
0.325	8.25	1110 893 4000
$\frac{3}{8}$	9.32	1110 893 4000
0.404	10.26	1106 893 4000

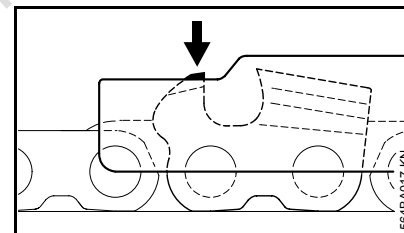

- Place the filing gauge on the saw chain. If the depth gauge projects beyond the filing gauge it has to be lowered.

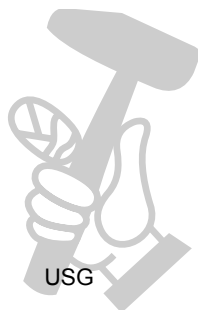

If the depth gauges have to be lowered:

- Select the correct grinding wheel – see instruction sheet 0457 716 0000
- Mount the grinding wheel – see "Mounting the Grinding Wheel".
- Test run the grinding wheel – see "Test Run".
- Check profile of grinding wheel and dress if necessary – see "Dressing the Grinding Wheel".

Setting the Scales

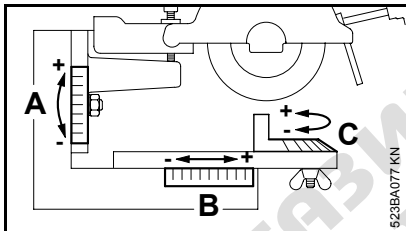

- Set scale **A** to 40°
- Set scales **B** and **C** to 0°

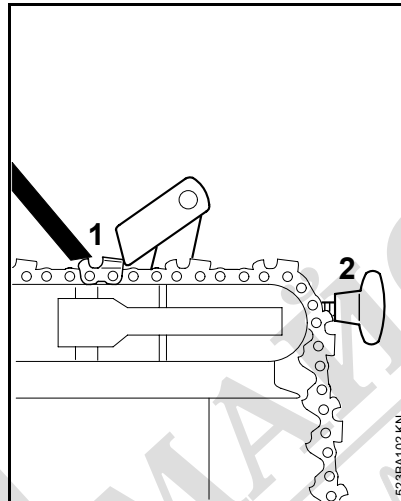

Adjusting the Lateral Stop

- Swing the motor arm down.
- Slide the chain along the guide rail until the profile (1) of the grinding wheel is centered above the depth gauge.
- Clamp the chain in position.
- Turn the adjusting screw (2) until the back of the cutter butts against the stop.

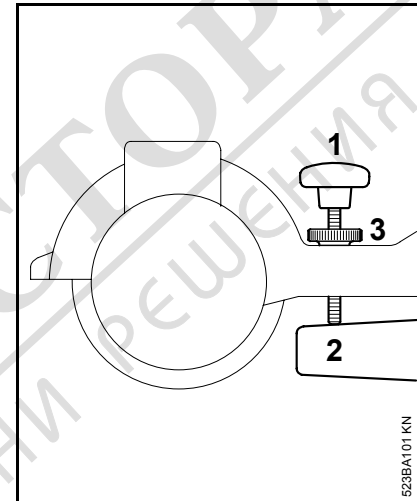

Adjusting Grinding Wheel

- Swing the motor arm down until the grinding wheel touches the depth gauge.
- Screw home the travel limiting screw (1) until it butts against the stop lug (2).
- Put on safety glasses.
- Switch on the motor.
- Carefully bring the motor arm down as far as the stop.

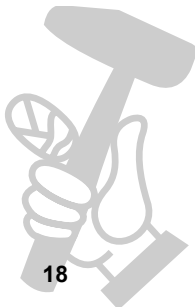

Setup for Sharpening Hedge Trimmer Blades

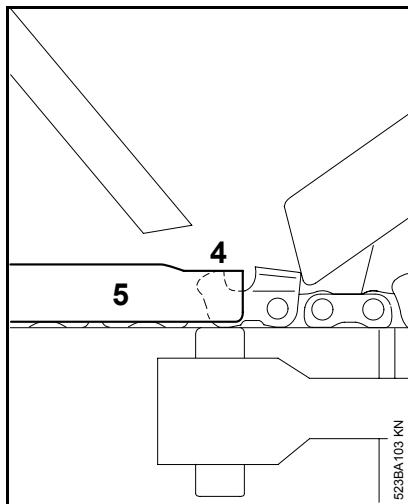

- Switch off the motor.
- Place the filing gauge (5) on the chain.
- If the depth gauge (4) still projects above the filing gauge, make appropriate adjustment with the travel limiting screw (1).
- Remove the filing gauge (5).
- Switch on the motor.
- Carefully bring the motor arm down.
- Switch off the motor.
- Repeat the procedure until the depth gauge is level with the filing gauge.

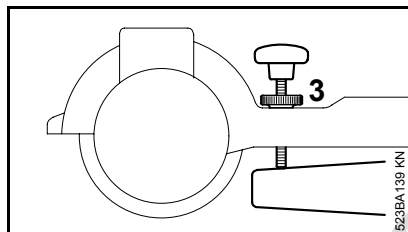

- Tighten down the knurled nut (3) firmly.
- Use this setting to lower all the other depth gauges.

⚠ The kickback tendency of the saw is increased if the depth gauges are too low.

⚠ On PM1 and RM2 chains the rear hump of the tie strap (with service mark) is lowered at the same time as the depth gauge. The other parts of the triple-humped tie strap must not be ground because this may increase the kickback tendency of the saw.

- Select the correct grinding wheel – see "Selecting Grinding Wheel".
- Mount the grinding wheel – see "Mounting the Grinding Wheel".
- Test run the grinding wheel – see "Test Run".
- Check profile of grinding wheel and dress if necessary – see "Dressing the Grinding Wheel".



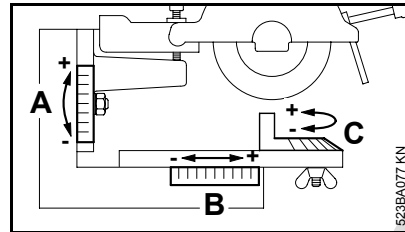
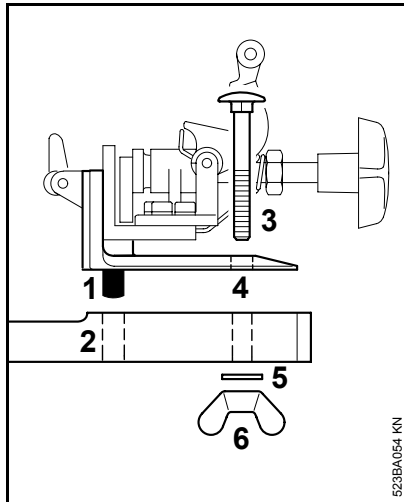

Setting the Scales

	HL 45, HL 75, HLR 85, HS 61 HS 75, 80, 85 HL 100, HS 246	HS 45
Scale A	- 10°	- 6°
Scale B	0	0
Scale C left	+ 45°	+ 55°
Scale C right	- 45°	- 55°

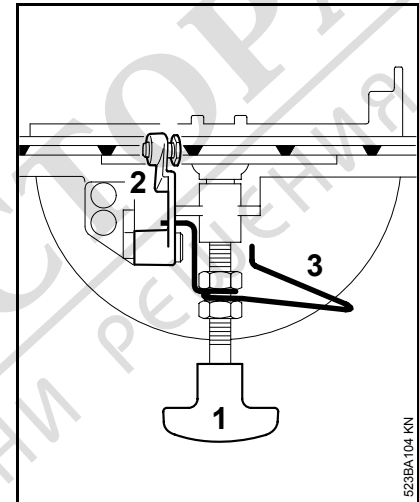

Mounting the Attachment for Hedge Trimmer Blades

- Engage pin (1) in hole (2) in base.
- Insert bolt (3) in slot (4).
- Fit the washer (5) and wingnut (6) and tighten down moderately.

Principle of Clamp

- Turn the star knob (1) to open and close the clamp.
The stop (2) is automatically engaged and disengaged by the spring (3).

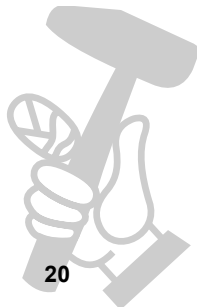

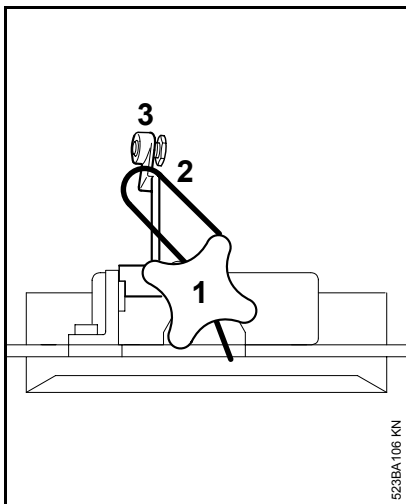

Fitting Cutting Blade

- Turn the star knob (1) until the spring (2) is in the position shown.
- The clamp is open in this position – the cutting blade may be fitted.

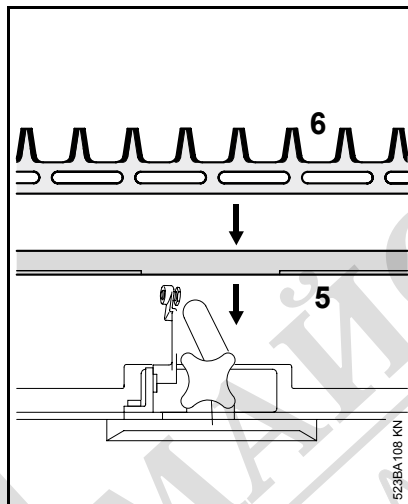

Fitting one-sided cutting blade

- Fit the angle iron rail (5).
- Fit the cutting blade (6) in position so that the cutting edges point to the rear.

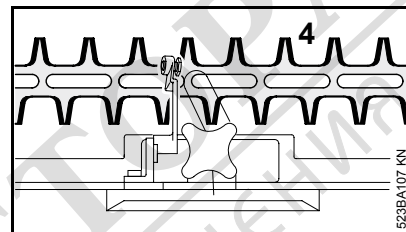

Fitting double-sided cutting blade

- Fit the cutting blade (4) in position so that the cutting edges point to the rear.



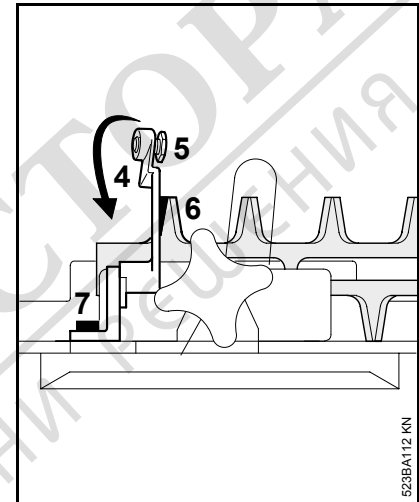
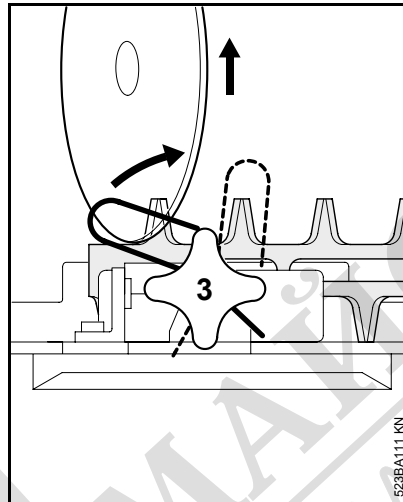
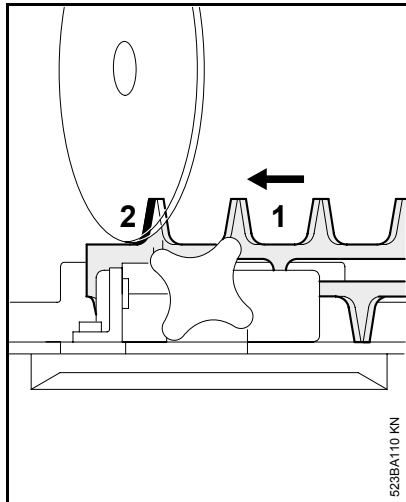

Adjusting the Stop

Adjusting the lateral stop

- Swing the motor arm down until the grinding wheel is above the gullet of the tooth – hold it in this position.
- Pull the cutting blade (1) to the left until the first tooth (2) in the row butts against the grinding wheel.

- Swing the motor arm up again.
- Turn the star knob (1) clockwise until the spring is in the position shown – the clamp is closed.

- Swing the stop (4) into position by hand.
- Turn the adjusting screw (5) until the stop butts against the tooth (6).
- If range of adjustment is insufficient, loosen the screws (7) on the stop.
- Move the stop (4) until it butts against the tooth and then tighten down the screws (7) firmly.

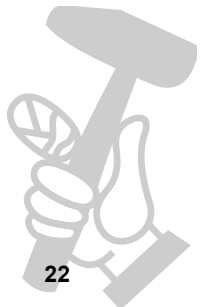

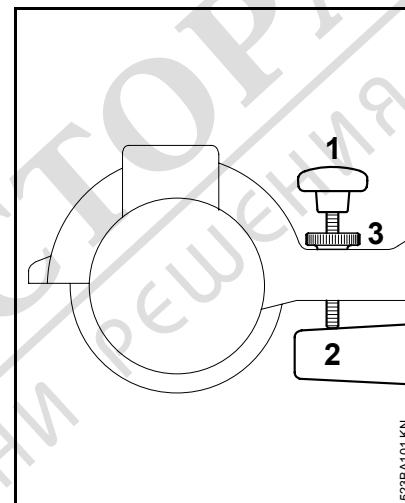
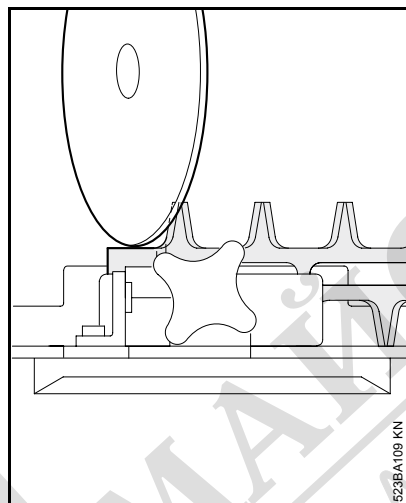
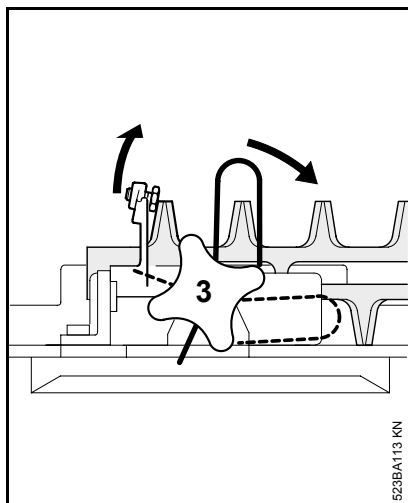

- If stop is now correctly positioned:
- Continue turning the star knob (3) clockwise until the stop swings back.

Adjusting sharpening depth

- Swing the motor arm down until the grinding wheel touches the gullet of the tooth – hold it in this position.

- Screw the travel limiting screw (1) down as far as the stop lug (2).
- Tighten down the knurled nut (3) firmly.

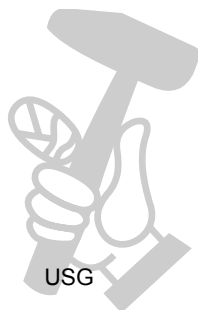

Sharpening Hedge Trimmer Blades

 Wear safety glasses to protect your eyes.

Observe the following points when sharpening:

- The cutting blade must be correctly clamped in position and the stop must swing back out of the way.
- Bring the motor arm slowly downward. Check sharpening process. Do not remove too much material. If necessary, switch off the motor and readjust.
- Sharpen the cutting edges by applying the wheel several times – do not sharpen in a single pass.

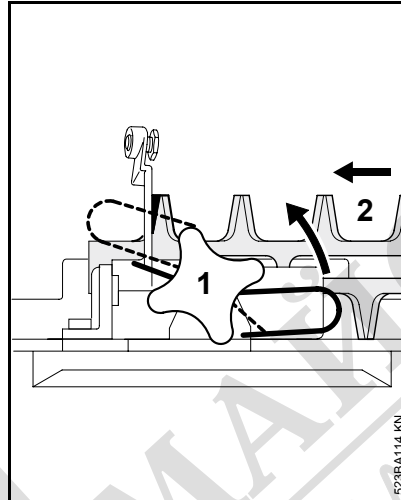

Sharpening Row of Teeth

- Switch on the motor.
- Sharpen the first tooth.
- Turn the star knob (1) counter-clockwise to loosen the clamp.
- Move cutting blade (2) one tooth to the left.
- Continue turning the star knob (1) until the stop swings forward automatically. The left tooth flank must butt against the stop.

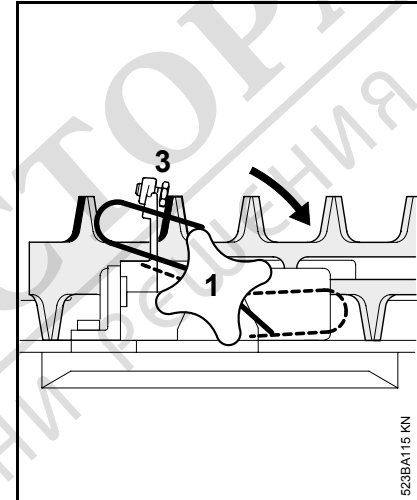

- Turn the star knob (1) clockwise until the stop swings back – the cutting blade is now clamped in position.
- Sharpen the tooth.

Repeat the above procedure until all the teeth in the row have been sharpened. Now follow the separate descriptions for sharpening one-sided and double-sided cutting blades.



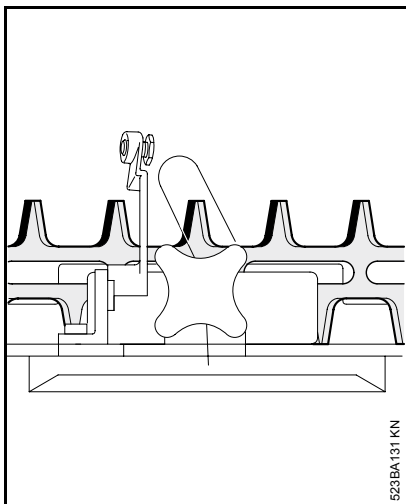

Sharpening Double-Sided Hedge Trimmer Blades

- Sharpen the first row of teeth – cutting edges point to the rear.

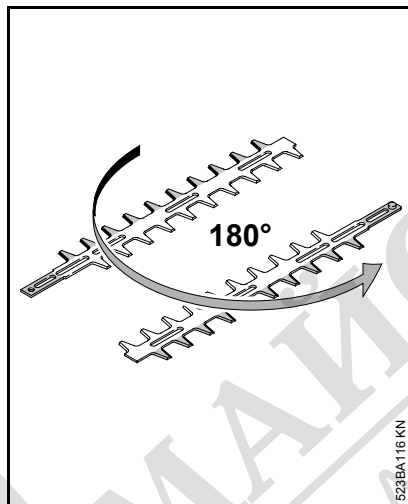

- Take the cutting blade out of the clamp and turn it 180° lengthwise – cutting edges point to the rear.
- Sharpen the teeth.

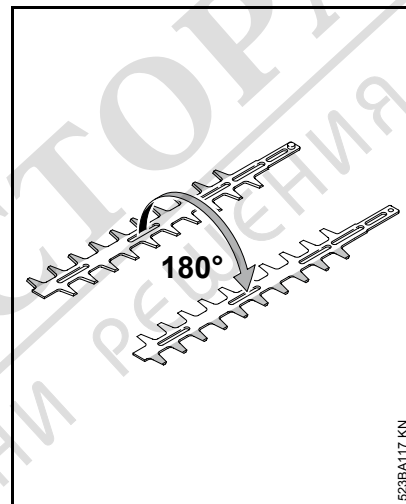

- Take the cutting blade out of the clamp and turn it over (180°) – cutting edges point forwards.
- Set scale **C** to opposite angle.
- Sharpen the teeth.

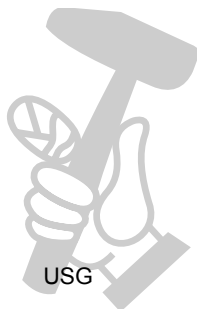

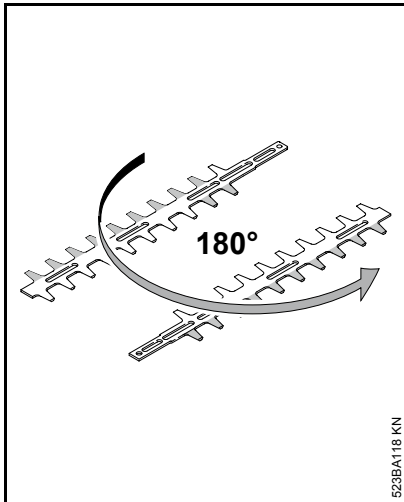

- Take the cutting blade out of the clamp and turn it 180° lengthwise – cutting edges point forwards.
- Sharpen the teeth.

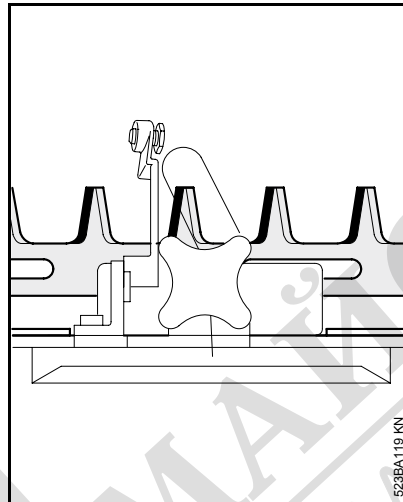

Sharpening One-Sided Hedge Trimmer Blades

- Sharpen the first row of teeth – cutting edges point to the rear.

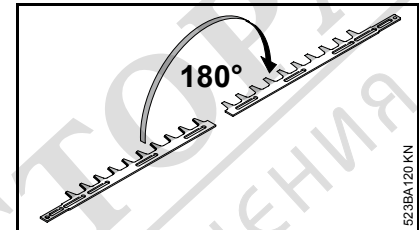

- Take the cutting blade out of the clamp and turn it over (180°) – cutting edges point forwards.
- Set scale C to opposite angle.
- Sharpen the teeth.

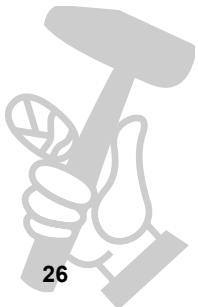

Preparations for Sharpening Circular Saw Blade

 Check the blade. Always perform a ringing test.

Do not continue to use warped or cracked blades since they may shatter.

- Select the correct grinding wheel – see "Selecting the Grinding Wheel".
- Mount the grinding wheel – see "Mounting the Grinding Wheel".
- Test run the grinding wheel – see "Test Run".
- Check profile of grinding wheel and dress if necessary – see "Dressing the Grinding Wheel".

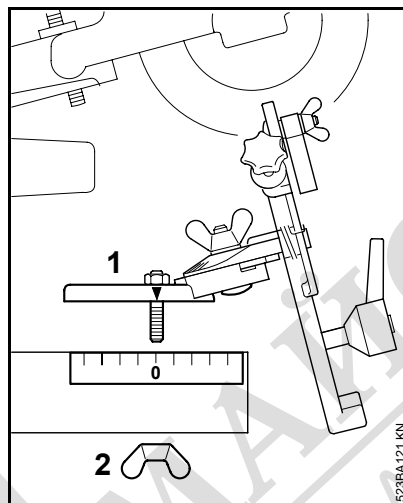

Mounting the Special Attachment

- Fit the attachment (1) so that the arrow points to "0" on the scale.
- Tighten down the wingnut (2) firmly.

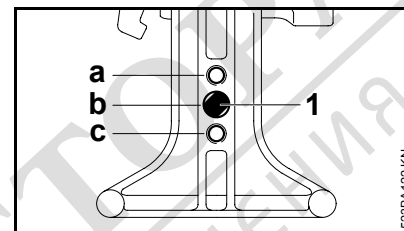

Clamping the Circular Saw Blade

- Use the tapped hole specified for the saw blade diameter:

a = for 200 mm blade

b = for 225 mm blade

c = for 250 mm blade

If necessary, change the position of the shoulder stud (1).



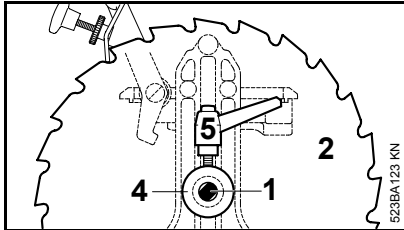

- Position the saw blade (2) on the shoulder stud (1) so that the cutting edges point to the left (counter-clockwise).
- Fit the locator (4) over the shoulder stud and push it home – this centers the saw blade.
- Tighten down the clamp lever (5) firmly.

The saw blade must now locate against the retaining plate free from play, but it must still be possible to turn the blade by hand.

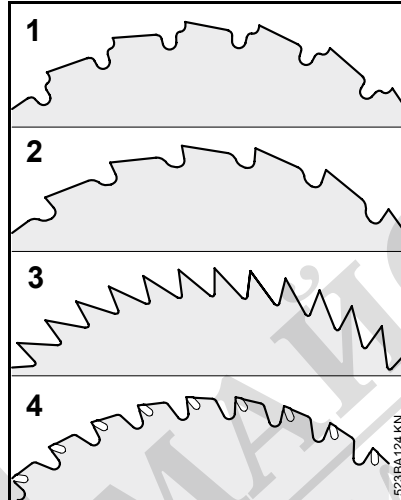

Setting the Scales

The settings depend on the type of saw blade:

- Chisel tooth, standard (1)
- Chisel tooth, special (2)
- Scratcher tooth (3)
- Carbide tipped blade (4)

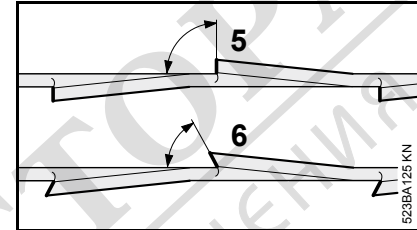

There are saw blades with square ground teeth (5) (scale **C** = 0) and bevel ground teeth (6)

💡 In the case of bevel ground teeth, mark the teeth that have the same sharpening angle (every second tooth). Marking them helps avoid accidentally sharpening a tooth on the other side of the blade.

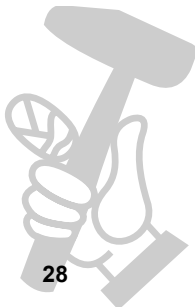

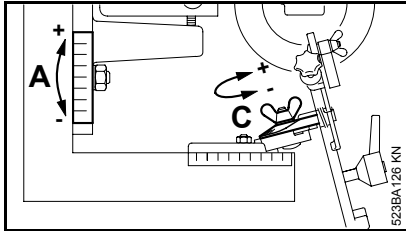

- Set angles as specified in the following table.

Type of tooth	Scale A	Scale C
Chisel tooth, standard	+5°...+15° ¹⁾	+15°/ -15°
Chisel tooth, special	+5°...+15° ¹⁾	+15°/ -15°
Scratcher tooth ²⁾	0°	0°
Carbide tipped blade	7°	+5°/-5°

- 1) Depending on type of wood, set between +5° (for hardwood) and +15° (for soft wood)
- 2) Scratcher tooth saw blade with 80 teeth cannot be sharpened with the USG

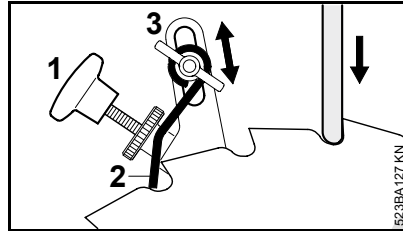

Adjusting the Stop

Adjusting the lateral stop

- Swing the motor arm down.
- Use the adjusting screw (1) to move the stop (2) so that the side plate of the tooth to be sharpened butts against the grinding wheel – make sure the stop locates firmly against the back of one tooth.
- The stop can be moved in the slot (3) to suit the saw blade.

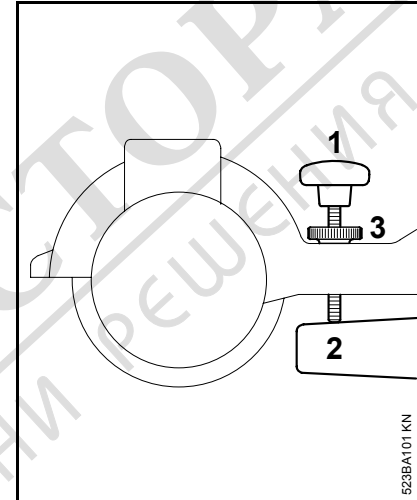

Adjusting sharpening depth

- Swing the motor arm down until the required sharpening depth is reached – see "Sharpening profiles".
- Screw home the travel limiting screw (1) until it butts against the stop lug (2).
- Tighten down the knurled nut (3) firmly.



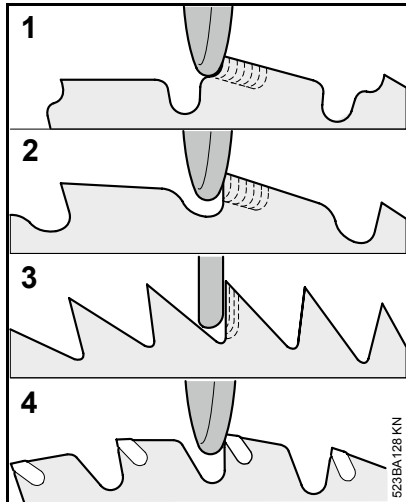

Sharpening profiles

Chisel tooth, standard (1)

Chisel tooth, special (2)

Scratcher tooth (3)

Carbide tipped blade (4)

Sharpening Limits

Chisel tooth:

- Sharpening depth: max. 5 mm
- Top plate must not be sharpened back to more than half its length.
- Tooth set must not be less than 1 mm.

Scratcher tooth

- Sharpening depth: no more than diameter of blade body.
- Do not reduce tooth height by more than 1/3.
- Do not touch back of next tooth with grinding wheel.

Carbide tipped blade

- Sharpen carbide tip only – do not sharpen material of blade body.

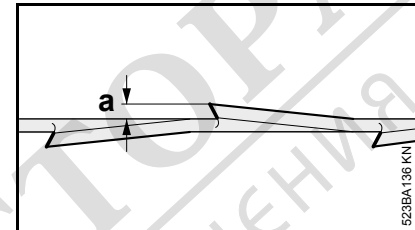

Checking Tooth Set

After sharpening chisel tooth saw blades:

- Use saw set (special accessory) to check tooth set (a) and correct if necessary.

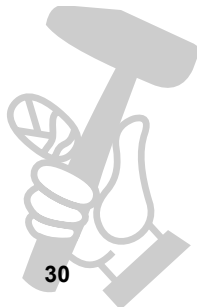

Sharpening Circular Saw Blade

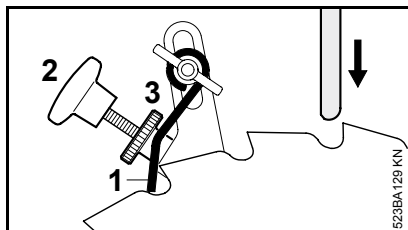

⚠ Wear safety glasses and work gloves.

Sharpening the First Tooth

- Push the saw blade clockwise against the stop (1) with your left hand.
- With the motor running, carefully swing the motor arm down.
- Only remove sufficient material to obtain a "clean" cutting edge. If necessary, use adjusting screw (2) to correct position of stop.

Sharpening Remaining Teeth

The sharpening process now depends on how the teeth are ground.

Saw blade **without** bevel ground teeth (scale **C** = 0°):

- Rotate the saw blade counter-clockwise to the next tooth.
- Sharpen all teeth with the same setting.

Saw blade **with** bevel ground teeth:

- Rotate the saw blade counter-clockwise to the **next tooth but one**.
- Sharpen all the teeth in one row that have the same sharpening angle (every second tooth).
- Then set scale **C** to the angle for the opposite row of teeth – all other settings are left unchanged, do not turn the saw blade over.
- Now sharpen all the teeth in the second row.

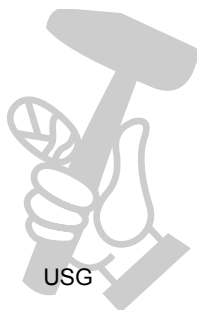

USG

Maintenance Chart

Please note that the following maintenance intervals apply for normal operating conditions. If your daily working time is longer than normal or conditions are difficult, shorten the specified intervals accordingly.

		before starting work	after finishing work or daily	weekly	monthly	if problem	if damaged	as required
Complete machine	Visual inspection condition)	X						
	Clean		X					
Machine mounting	Check	X						
	Retighten							X
Switch	Check operation	X						
	Replace ¹⁾					X	X	
Power supply cord	Check	X						
	Replace ¹⁾					X	X	
Grinding wheel	Check (wear)	X						
	Check profile			X				
	Dress			X				X
	Replace						X	X
Cooling air inlets	Clean		X					
Accessible screws and nuts	Retighten							X
Shield	Check	X						
	Replace						X	X
Clamp and guide rail	Check	X						
	Replace							X
Stop and lock	Check	X						
	Replace							X

1) Have work performed by qualified electrician



Minimize Wear and Avoid Damage

Observing the instructions in this manual helps reduce the risk of unnecessary wear and damage to the unit.

The unit must be operated, maintained and stored with the due care and attention described in this owner's manual.

The user is responsible for all damage caused by non-observance of the safety precautions, operating and maintenance instructions in this manual. This includes in particular:

- Alterations or modifications to the product not approved by STIHL.
- Using attachments or sharpening tools not approved by STIHL.
- Using the product for purposes for which it was not designed.
- Consequential damage caused by continuing to use the product with defective components.

Maintenance Work

All the operations described in the “Maintenance Chart” must be performed on a regular basis. If these maintenance operations cannot be performed by the owner, they should be performed by an authorized STIHL servicing dealer.

If these operations are not carried out as specified, the user assumes responsibility for any damage that may occur.

Among other things, this includes:

- Damage to the unit due to neglect or deficient maintenance.
- Corrosion and other consequential damage resulting from improper storage.
- Damage and consequential damage resulting from the use of parts other than original STIHL replacement parts.
- Damage resulting from maintenance or repair work not performed by authorized STIHL servicing dealers.

Parts Subject to Wear and Tear

Some parts of the unit are subject to normal wear and tear even during regular operation in accordance with instructions and, depending on the type and duration of use, have to be replaced in good time.

Among other parts, this includes:

- Grinding wheels
- Carbon brushes
- Transparent shield
- Clamping lever and thrust pad
- Clamping and guide rails
- Stop



Main Parts of Sharpener

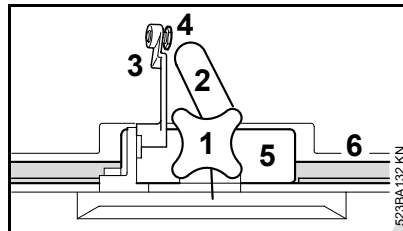
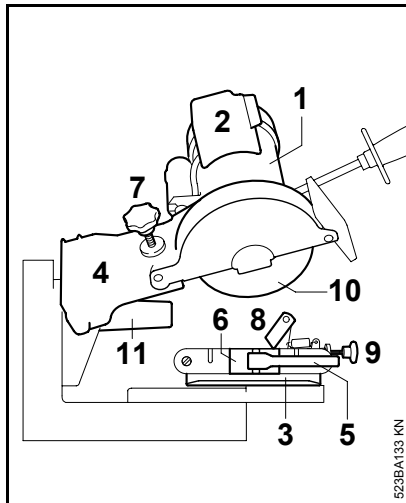

Attachment for hedge trimmer blades

- 1 Star knob
- 2 Spring
- 3 Stop
- 4 Adjusting screw
- 5 Clamp
- 6 Angle iron rail

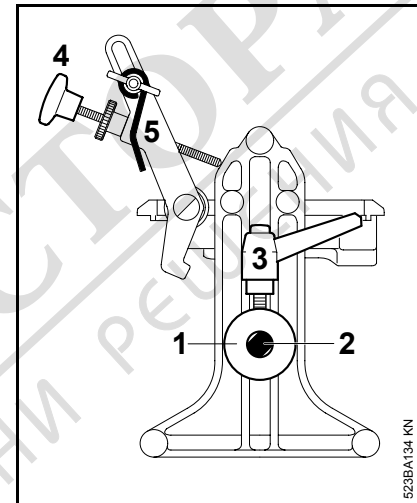

Attachment for circular saw blades

- 1 Locator
- 2 Shoulder stud
- 3 Clamping lever
- 4 Adjusting screw
- 5 Stop

USG with attachment for Oilomatic saw chain

- 1 Motor
- 2 Switchbox
- 3 Attachment
- 4 Motor arm
- 5 Clamping lever
- 6 Thrust plate
- 7 Travel limiting screw
- 8 Stop
- 9 Adjusting screw
- 10 Grinding wheel
- 11 Stop lug



Specifications

Motor

Type:	Single-phase AC, squirrel-cage motor
Operating voltage:	230 V
Frequency:	50 Hz
Rated current:	1.3 A
Power rating:	0.18 kW
Motor speed:	2,800 RPM
Equivalent sound pressure level ¹⁾ L _{peq}	75 dB (A)

Special Accessories

Work light
 Foot-operated clamping attachment
 Diamond dressing attachment
 Filing gauge
 Diamond grinding wheel for carbide
 tipped saw chain and carbide tipped
 circular saw blades
 Attachment (tool rest) for scratcher tooth
 chain
 Attachment (tool rest) for hedge trimmer
 blades
 Attachment (tool rest) for circular saw
 blades
 Saw set for checking and correcting
 tooth set

Contact your STIHL dealer for the latest
 information on these and other special
 accessories.

Maintenance and Repairs

The user of this unit should carry out
 only the maintenance operations
 described in this manual. Other repair
 work may be performed only by an
 authorized STIHL dealer.

Warranty claims following repairs can be
 accepted only if the repair has been
 performed by an authorized STIHL
 dealer using original STIHL replacement
 parts.

Original STIHL parts can be identified by
 the STIHL part number, the **STIHL**
 logo and the STIHL parts symbol **GI**.
 The symbol may appear alone on small
 parts.

¹⁾ according to EN ISO 11204,
 measured at operator's ear while
 sharpening a saw chain

English

Certificate of Conformity

Andreas Stihl AG & Co. KG
Badstr. 115
71336 Waiblingen

certify that the new machine described
below

Category: Universal
sharpeners
Make: STIHL
Model: USG
Serial identification: 5203

conforms to the specifications of
Directives 73/23/EEC, 98/37/EG and
89/336/EEC.

The product has been developed and
manufactured in compliance with the
following standards:
EN 60335-1, EN 55014-1, EN 55014-2,
EN 61000-3-2, EN 61000-3-3 and
EN 60204-1

Technical documents deposited at:
Andreas Stihl AG & Co. KG
Product Licensing

Done at Waiblingen,
September 1, 2003

Andreas Stihl AG & Co. KG



Steinhauser
Director
Group Product Management/
Engineering Services

Quality Certification [®]



All STIHL products comply with the
highest quality standards.

An independent organization has
certified that all products manufactured
by STIHL meet the strict requirements of
the ISO 9001 standard for quality
management systems in terms of
product development, materials
purchasing, production, assembly,
documentation and customer service.

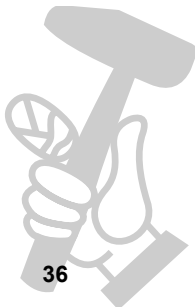

МАГАЗИН
БАШ МАЙСТОРА[®]
ПРОФЕССИОНАЛНИ РЕШЕНИЯ



englisch / english