



# TITAN®

## OPERATING MANUAL

- E -	INSTRUCCIONES DE USO	30
- P -	MANUAL DE PROPRIETÁRIO	58

# ИМПАКТ 540

AIRLESS, HIGH-PRESSURE  
SPRAYING UNIT

AIRLESS EQUIPO DE ALTA  
PRESIÓN PARA PULVERIZAR

UNIDADE DE PULVERIZAÇÃO DE  
ALTA PRESSÃO AIRLESS

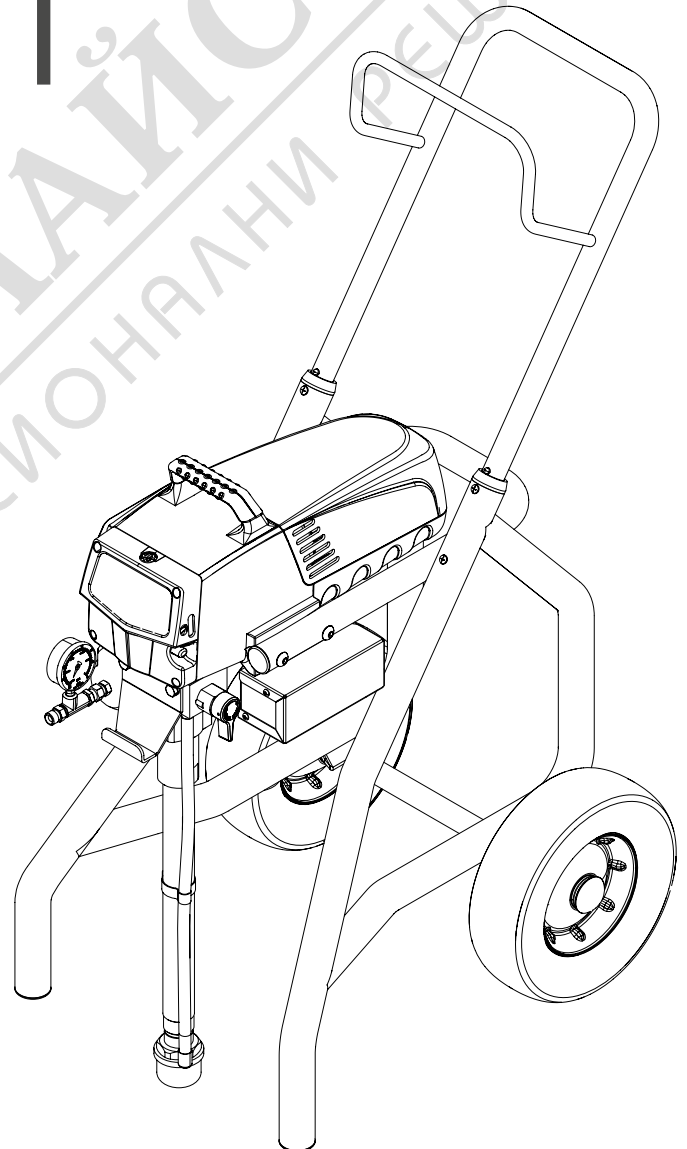
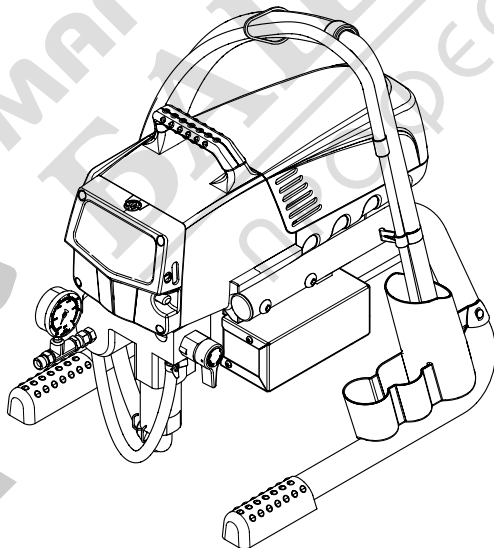

**MODEL**

**0532031**

**0532039**

# Warning!

**Attention: Danger of injury by injection!**  
**Airless units develop extremely high spraying pressures.**

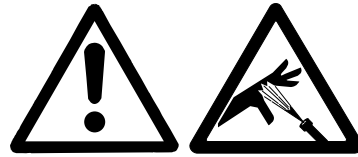
**1**

**Never put your fingers, hands or any other parts of the body into the spray jet!**

**Never point the spray gun at yourself, other persons or animals.**

**Never use the spray gun without safety guard.**

**Do not treat a spraying injury as a harmless cut. In case of injury to the skin through coating materials or solvents, consult a doctor immediately for quick and expert treatment. Inform the doctor about the coating material or solvent used.**

**2**

**The operating instructions state that the following points must always be observed before starting up:**

1. Faulty units must not be used.
2. Secure Titan spray gun using the trigger lock on the trigger.
3. Ensure that the unit is properly earthed.
4. Check allowable operating pressure of high-pressure hose and spray gun.
5. Check all connections for leaks.

**3**

**The instructions regarding regular cleaning and maintenance of the unit must be strictly observed.**

**Before any work is done on the unit or for every break in work the following rules must be observed:**

1. Release the pressure from spray gun and hose.
2. Secure the Titan spray gun using the trigger lock on the trigger.
3. Switch off unit.



# Be safety conscious!

<b>1</b>	<b>SAFETY REGULATIONS FOR AIRLESS SPRAYING</b>	<b>4</b>	<b>8</b>	<b>CLEANING THE UNIT (SHUTTING DOWN)</b>	<b>18</b>
1.1	Explanation of symbols used	4	8.1	Cleaning unit from outside	18
1.2	Electric safety	8	8.2	Suction filter	18
1.3	Electrostatic charging (formation of sparks or flames)	8	8.3	Cleaning the high-pressure filter	19
			8.4	Cleaning Airless spray gun	19
<b>2</b>	<b>GENERAL VIEW OF APPLICATION</b>	<b>9</b>	<b>9</b>	<b>REMEDY IN CASE OF FAULTS</b>	<b>20</b>
2.1	Application	9	<b>10</b>	<b>SERVICING</b>	<b>21</b>
2.2	Coating materials	9	10.1	General servicing	21
<b>3</b>	<b>DESCRIPTION OF UNIT</b>	<b>10</b>	10.2	High-pressure hose	21
3.1	Airless process	10	<b>11</b>	<b>REPAIRS AT THE UNIT</b>	<b>21</b>
3.2	Functioning of the unit	10	11.1	Relief valve	21
3.3	Legend for explanatory diagram Impact 540	10	11.2	Inlet and outlet valve	22
3.4	Explanatory diagram Impact 540	11	11.3	Packings	23
3.5	Technical data	12	11.4	Replacing the motor	24
3.6	Transportation	12	11.5	Replacing the gears	25
<b>4</b>	<b>STARTING OPERATION</b>	<b>13</b>	11.6	Replacing the transducer	26
4.1	High-pressure hose, spray gun and separating oil	13	11.7	Impact 540 connection diagram	27
4.2	Control panel indicators	13	<b>12</b>	<b>APPENDIX</b>	<b>28</b>
4.3	Pressure control knob settings	14	12.1	Selection of tip	28
4.4	Connection to the mains network	14	12.2	Servicing and cleaning of Airless hard-metal tips	28
4.5	Cleaning preserving agent when starting-up of operation initially	15	<b>WARRANTY</b>		<b>29</b>
4.6	Taking the unit into operation with coating material	15	<b>SPARE PARTS LISTS</b>		<b>86</b>
<b>5</b>	<b>SPRAYING TECHNIQUE</b>	<b>16</b>	Spare parts list for main assembly		86/87
<b>6</b>	<b>HANDLING THE HIGH-PRESSURE HOSE</b>	<b>17</b>	Spare parts list for the fluid section		88/89
<b>7</b>	<b>INTERRUPTION OF WORK</b>	<b>17</b>	Spare parts list for drive assembly		90
			Spare parts list for upright cart		91
			Spare parts list of stand		92
			Spare parts list for suction system		93
			<b>ACCESSORIES</b>		<b>94/95</b>

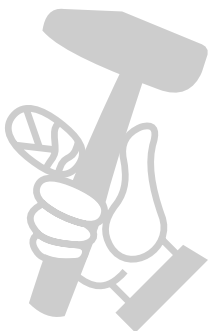

# 1 SAFETY REGULATIONS FOR AIRLESS SPRAYING

## 1.1 EXPLANATION OF SYMBOLS USED

This manual contains information that must be read and understood before using the equipment. When you come to an area that has one of the following symbols, pay particular attention and make certain to heed the safeguard.



→ This symbol indicates a potential hazard that may cause serious injury or loss of life. Important safety information will follow.



Attention

→ This symbol indicates a potential hazard to you or to the equipment. Important information that tells how to prevent damage to the equipment or how to avoid causes of minor injuries will follow.



→ Danger of skin injection



→ Danger of fire from solvent and paint fumes



→ Danger of explosion from solvent, paint fumes and incompatible materials



→ Danger of injury from inhalation of harmful vapors



→ Notes give important information which should be given special attention.



### HAZARD: INJECTION INJURY

Attention: Danger of injury by injection! A high pressure stream produced by this equipment can pierce the skin and underlying tissues, leading to serious injury and possible amputation.

Do not treat a spraying injury as a harmless cut. In case of injury to the skin through coating materials or solvents, consult a doctor immediately for quick and expert treatment. Inform the doctor about the coating material or solvent used.

### PREVENTION:

- NEVER aim the gun at any part of the body.
- NEVER allow any part of the body to touch the fluid stream. DO NOT allow body to touch a leak in the fluid hose.
- NEVER put your hand in front of the gun. Gloves will not provide protection against an injection injury.
- ALWAYS lock the gun trigger, shut the fluid pump off and release all pressure before servicing, cleaning the tip guard, changing tips, or leaving unattended. Pressure will not be released by turning off the engine. The PRIME/SPRAY valve or pressure bleed valve must be turned to their appropriate positions to relieve system pressure.
- ALWAYS keep tip guard in place while spraying. The tip guard provides some protection but is mainly a warning device.
- ALWAYS remove the spray tip before flushing or cleaning the system.
- NEVER use a spray gun without a working trigger lock and trigger guard in place.

- All accessories must be rated at or above the maximum operating pressure range of the sprayer. This includes spray tips, guns, extensions, and hose.

**HAZARD: HIGH PRESSURE HOSE**

The paint hose can develop leaks from wear, kinking and abuse. A leak can inject material into the skin. Inspect the hose before each use.

**PREVENTION:**

- Avoid sharp bending or kinking of the high-pressure hose. The smallest bending radius amounts to about 20 cm.
- Do not drive over the high-pressure hose. Protect against sharp objects and edges.
- Replace any damaged high-pressure hose immediately.
- Never repair defective high-pressure hoses yourself!
- Electrostatic charging of spray guns and the high-pressure hose is discharged through the high-pressure hose. For this reason the electric resistance between the connections of the high-pressure hose must be equal to or lower than 1MΩ.
- For reasons of function, safety and durability use only original Titan high-pressure hoses.
- Before each use, check all hoses for cuts, leaks, abrasion or bulging of cover. Check for damage or movement of couplings. Immediately replace the hose if any of these conditions exist. Never repair a paint hose. Replace it with another earthed high-pressure hose.
- Make sure power cord, air hose and spray hoses are routed in such a manner to minimize slip, trip and fall hazard.

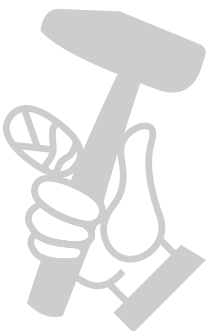

**HAZARD: EXPLOSION OR FIRE**

Flammable vapors, such as solvent and paint vapors, in work area can ignite or explode.

**PREVENTION:**

- Do not use materials with a flashpoint below 38° C (100° F). Flashpoint is the temperature at which a fluid can produce enough vapors to ignite.
- Do not use the unit in work places which are covered by the explosion protection regulations.
- Provide extensive exhaust and fresh air introduction to keep the air within the spray area free from accumulation of flammable vapors.
- Avoid all ignition sources such as static electricity sparks, electrical appliances, flames, pilot lights, hot objects, and sparks from connecting and disconnecting power cords or working light switches.
- Do not smoke in spray area.
- Place sprayer sufficient distance from the spray object in a well ventilated area (add more hose if necessary). Flammable vapors are often heavier than air. Floor area must be extremely well ventilated. The pump contains arcing parts that emit sparks and can ignite vapors.
- The equipment and objects in and around the spray area must be properly grounded to prevent static sparks.
- Use only conductive or earthed high pressure fluid hose. Gun must be earthed through hose connections.
- Power cord must be connected to a grounded circuit (electric units only).
- Always flush unit into separate metal container, at low pump pressure, with spray tip removed. Hold gun firmly against side of

container to ground container and prevent static sparks.

- Follow material and solvent manufacturer's warnings and instructions. Be familiar with the coating material's MSDS sheet and technical information to ensure safe use.
- Use lowest possible pressure to flush equipment.
- When cleaning the unit with solvents, the solvent should never be sprayed or pumped back into a container with a small opening (bunghole). An explosive gas/air mixture can arise. The container must be earthed.
- Do not use a paint or solvent containing halogenated hydrocarbons. Such as chlorine, bleach, mildewcide, methylene chloride and trichloroethane. They are not compatible with aluminum. Contact the coating supplier about compatibility of material with aluminum.

**HAZARD: HAZARDOUS VAPORS**

Paints, solvents, and other materials can be harmful if inhaled or come in contact with body. Vapors can cause severe nausea, fainting, or poisoning.

**PREVENTION:**

- Wear respiratory protection when spraying. Read all instructions supplied with the mask to be sure it will provide the necessary protection.
- All local regulations regarding protection against hazardous vapors must be observed.
- Wear protective eyewear.
- Protective clothing, gloves and possibly skin protection cream are necessary for the protection of the skin. Observe the regulations of the manufacturer concerning coating materials, solvents and cleaning agents in preparation, processing and cleaning units.

**HAZARD: GENERAL**

This product can cause severe injury or property damage.

**PREVENTION:**

- Follow all appropriate local, state, and national codes governing ventilation, fire prevention, and operation.
- Pulling the trigger causes a recoil force to the hand that is holding the spray gun. The recoil force of the spray gun is particularly powerful when the tip has been removed and a high pressure has been set on the airless pump. When cleaning without a spray tip, set the pressure control knob to the lowest pressure.
- Use only manufacturer authorized parts. User assumes all risks and liabilities when using parts that do not meet the minimum specifications and safety devices of the pump manufacturer.
- ALWAYS follow the material manufacturer's instructions for safe handling of paint and solvents.
- Clean up all material and solvent spills immediately to prevent slip hazard.
- Wear ear protection. This unit can produce noise levels above 85 dB(A).
- Never leave this equipment unattended. Keep away from children or anyone not familiar with the operation of airless equipment.
- Device weighs in excess of 18 kg. Two-person lift is required.
- Do not spray on windy days.
- The device and all related liquids (i.e. hydraulic oil) must be disposed of in an environmentally friendly way.

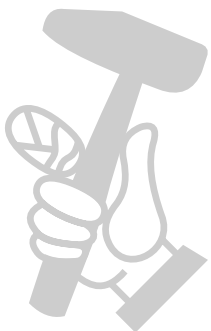

## 1.2 ELECTRIC SAFETY

Electric models must be earthed. In the event of an electrical short circuit, earthing reduces the risk of electric shock by providing an escape wire for the electric current. This product is equipped with a cord having an earthing wire with an appropriate earthing plug. Connection to the mains only through a special feed point, e.g. through an error protection installation with INF < 30 mA.



**DANGER** — Work or repairs at the electrical equipment may only be carried out by a skilled electrician. No liability is assumed for incorrect installation. Switch the unit off. Before all repair work, unplug the power plug from the outlet.

Danger of short-circuits caused by water ingressing into the electrical equipment. Never spray down the unit with high-pressure or high-pressure steam cleaners.

### WORK OR REPAIRS AT THE ELECTRICAL EQUIPMENT:

These may only be carried out by a skilled electrician. No liability is assumed for incorrect installation.

## 1.3 ELECTROSTATIC CHARGING (FORMATION OF SPARKS OR FLAMES)



Electrostatic charging of the unit may occur during spraying due to the flow speed of the coating material. These can cause sparks and flames upon discharge. The unit must therefore always be earthed via the electrical system. The unit must be connected to an appropriately-grounded safety outlet.

An electrostatic charging of spray guns and the high-pressure hose is discharged through the high-pressure hose. For this reason the electric resistance between the connections of the high-pressure hose must be equal to or lower than 1 MΩ.

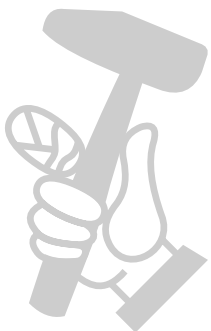



## 2 GENERAL VIEW OF APPLICATION

### 2.1 APPLICATION

The unit performance is conceived so that its use is possible on building sites for small- to middle-area dispersion work.

#### EXAMPLES OF OBJECTS TO BE SPRAYED

The sprayer is able for all common varnishing jobs like doors, door frames, balustrades, furniture, woodencladding, fences, radiators (heating) and steel parts.

### 2.2 COATING MATERIALS

#### PROCESSIBLE COATING MATERIALS

	Pay attention to the Airless quality of the coating materials to be processed.
---	--

Dilutable lacquers and paints or those containing solvents, two-component coating materials, dispersions, latex paints, release agents, oils, undercoats, primers, and fillers.

No other materials should be used for spraying without Titan's approval.

#### FILTERING

Despite suction filter and insertion filter in the spray gun, filtering of the coating material is generally advisable.

Stir coating material before commencement of work.

	Attention: Make sure, when stirring up with motor-driven agitators that no air bubbles are stirred in. Air bubbles disturb when spraying and can, in fact, lead to interruption of operation.
--	---

#### VISCOSITY

With this unit it is possible to process highly viscous coating materials of up to around 20.000 MPa·s.

If highly viscous coating materials cannot be taken in by suction, they must be diluted in accordance with the manufacturer's instructions.

#### TWO-COMPONENT COATING MATERIAL

The appropriate processing time must be adhered to exactly. Within this time rinse through and clean the unit meticulously with the appropriate cleaning materials.

#### COATING MATERIALS WITH SHARP-EDGED ADDITIONAL MATERIALS

These have a strong wear and tear effect on valves, high-pressure hose, spray gun and tip. The durability of these parts can be reduced appreciably through this.

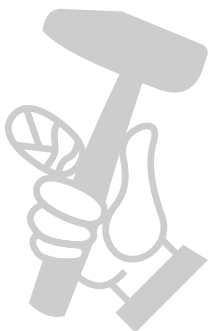

### 3 DESCRIPTION OF UNIT

#### 3.1 AIRLESS PROCESS

The main areas of application are thick layers of highly viscous coating material for large areas and a high consumption of material.

A piston pump takes in the coating material by suction and conveys it to the tip. Pressed through the tip at a pressure of up to a maximum of 221 bar (22.1 MPa), the coating material is atomised. This high pressure has the effect of micro fine atomisation of the coating material.

As no air is used in this process, it is described as an AIRLESS process.

This method of spraying has the advantages of finest atomisation, cloudless operation and a smooth, bubble-free surface. As well as these, the advantages of the speed of work and convenience must be mentioned.

#### 3.2 FUNCTIONING OF THE UNIT

In the following there is a short description of the technical construction for better understanding of the function.

Titan Impact 540 units are electrically driven high-pressure spraying units.

A gear unit transfers the driving force to a crankshaft. The crankshaft moves the pistons of the material feed pump up and down.

The inlet valve is opened automatically by the upwards movement of the piston. The outlet valve is opened when the piston moves downward.

The coating material flows under high pressure through the high-pressure hose to the spray gun. When the coating material exits from the tip it atomizes.

The pressure control knob controls the volume and the operating pressure of the coating material.

#### 3.3 LEGEND FOR EXPLANATORY DIAGRAM IMPACT 540

1. Spray gun
2. High-pressure hose
3. Return hose
4. Suction hose
5. Oil level gauge
6. Oil button
7. Relief valve  
Lever position vertical – PRIME (↻ circulation)  
Lever position horizontal – SPRAY (↗)
8. ON/OFF switch
9. Control panel indicators
10. Pressure control knob
11. Oil cup for Piston Lube (Piston Lube prevents increased wear of the packings)
12. Manometer
13. Pail bracket

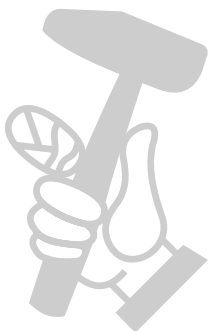

**3.4 EXPLANATORY DIAGRAM IMPACT 540**

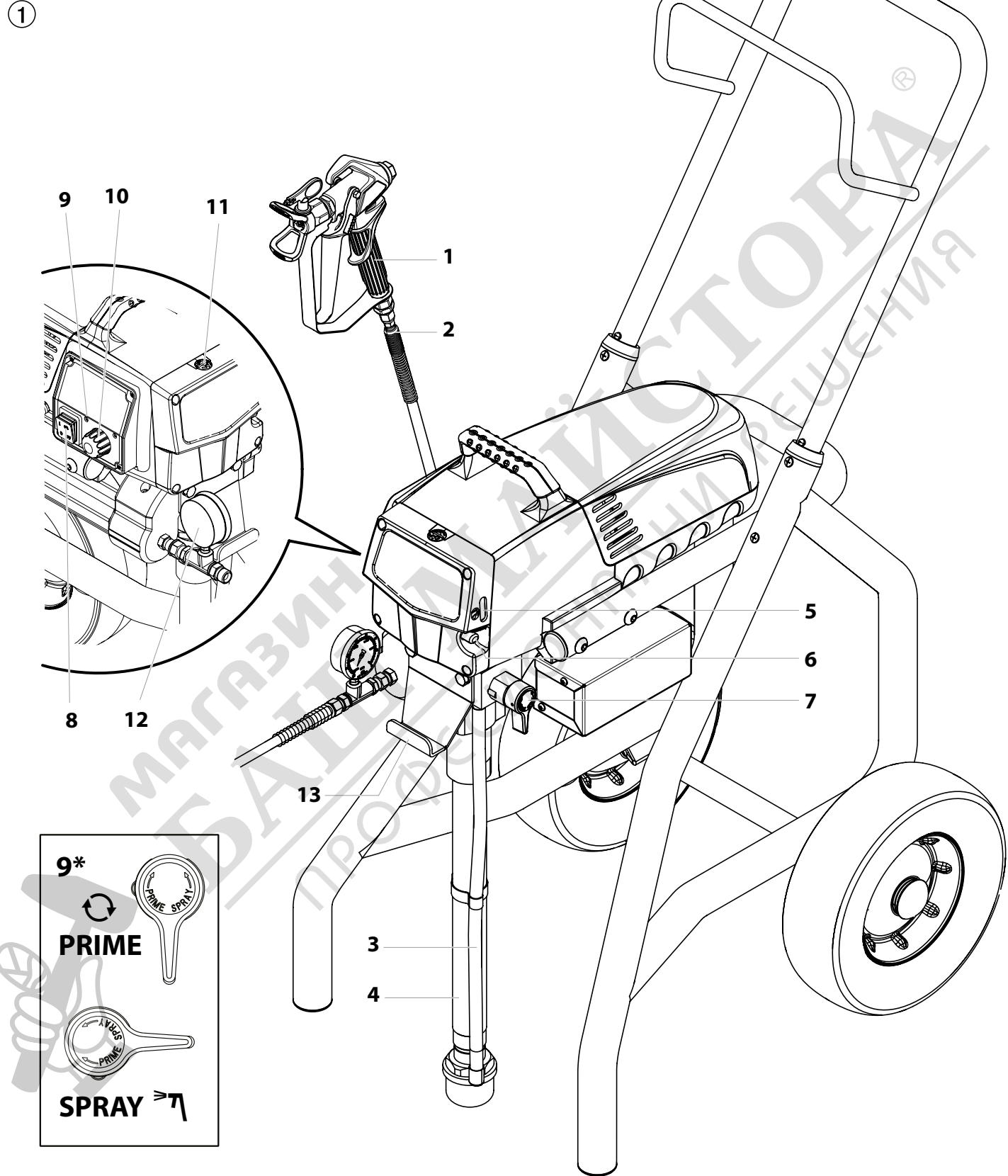

### 3.5 TECHNICAL DATA

<b>Voltage</b>	220~240 VAC, 50/60 Hz
<b>Max. current consumption</b>	6.0 A
<b>Power Cord</b>	See page 86
<b>Acceptance capacity</b>	1035 Watt
<b>Max. operating pressure</b>	221 bar (22.1 MPa)
<b>Volume flow at 12 MPa (120 bar) with water</b>	2.3 l/min
<b>Max tip size</b>	0.024 inch – 0.61 mm
<b>Max. temperature of the coating material</b>	43°C
<b>Max viscosity</b>	20.000 MPa-s
<b>Weight</b>	
Cart	27.4 kg
Stand	17.7 kg
<b>Special high-pressure hose</b>	DN 6 mm, 15 m, connection thread M 16 x 1.5
<b>Dimensions (L X W X H)</b>	
Cart	611 x 481 x 734 mm
Stand	436 x 369 x 416 mm
<b>Altitude</b>	This equipment will operate correctly up to 2000 m above mean sea level
<b>Vibration</b>	Spray gun does not exceed 2.5m/s <sup>2</sup>
<b>Max sound pressure level</b>	80 dB*

\* Place of measurement: 1 m distance from unit and 1.60m above floor, 12 MPa (120 bar) operating pressure, reverberant floor

### 3.6 TRANSPORTATION

#### Pushing or pulling the unit

Pull out the handle (Fig. 2, Item 1) until it will come no further. Insert the handle – push the buttons (2) on the spars, and then push in the handle.

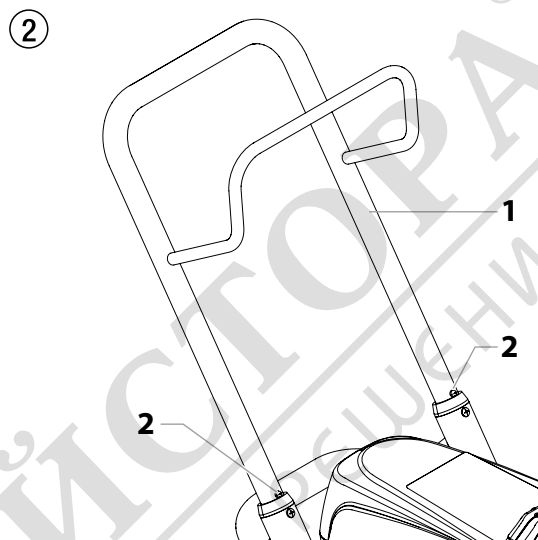

## 4 STARTING OPERATION

### 4.1 HIGH-PRESSURE HOSE, SPRAY GUN AND SEPARATING OIL

1. Screw the pressure gauge (1) to the coating material outlet (Fig. 3, Item 2).
2. Screw the high-pressure hose (3) to the coating material outlet (Fig. 3, Item 4).
3. Screw the spray gun (5) with the selected tip onto the high-pressure hose.
4. Tighten the union nuts at the high-pressure hoses firmly so that coating material does not leak.

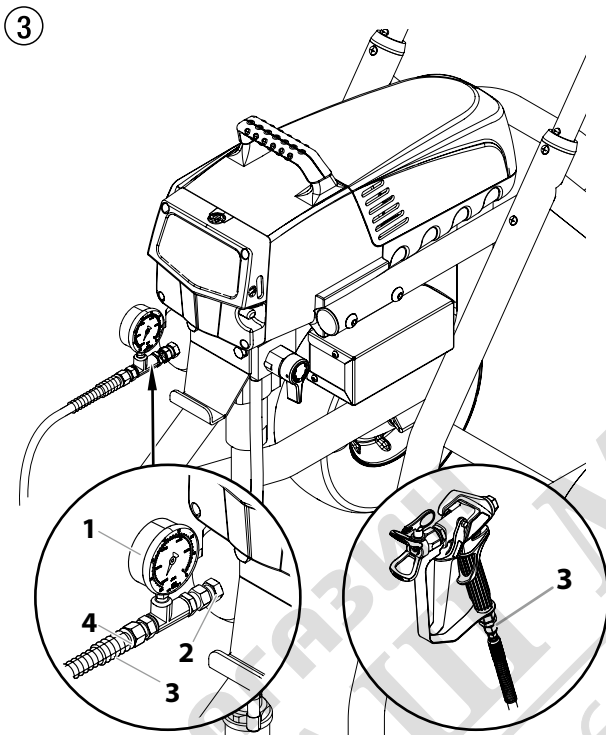

5. Remove the oil cup cap with a straight-slot screwdriver.
6. Fill the oil cup with Piston Lube (Fig. 4). Do not use too much Piston Lube, i.e. ensure that no Piston Lube drips into the coating material container.

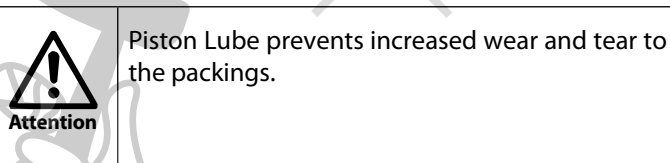

7. Replace oil cup cap.
8. Press oil button 2-5 times to prime the oiler. Press once for every eight hours of usage to lubricate the fluid section.

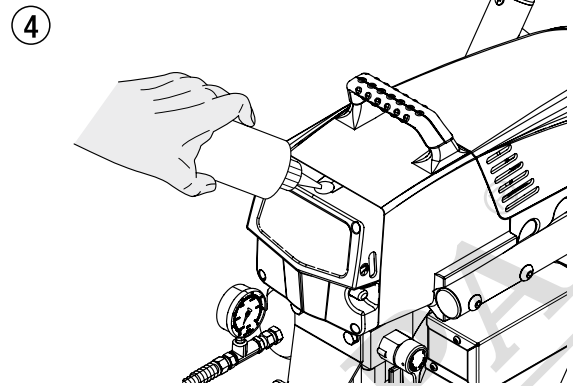

### 4.2 CONTROL PANEL INDICATORS

The following is a description of the control panel indicators.

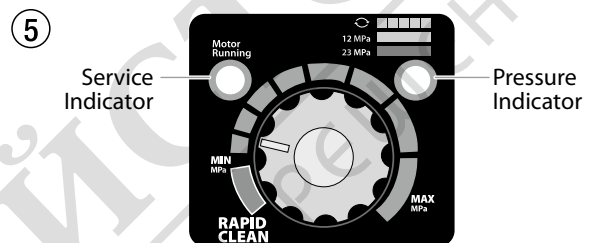

#### SERVICE INDICATOR

The Service indicator is on when the motor is commanded to run. This indicator is used by service centers to troubleshoot motor problems.

#### PRESSURE INDICATOR

The pressure indicator shows the current operating pressure of the sprayer. It has three different indications: blinking yellow, solid yellow, and solid green.

#### Blinking Yellow

When the pressure indicator is blinking yellow, the sprayer is operating between 0 and 1.4 MPa (14 bar). A blinking yellow pressure indicator means:

- The sprayer is plugged in and turned "ON"
- The sprayer is at priming pressure (little or no pressure)
- It is safe to move the relief valve between positions
- It is safe to change or replace the spray tip

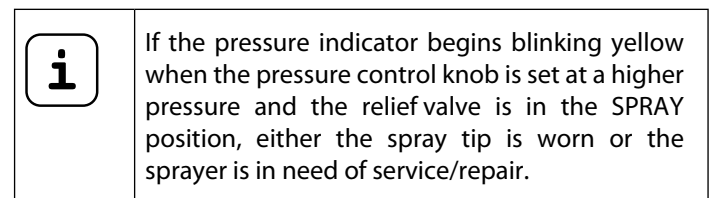

**Solid Yellow**

When the pressure indicator is solid yellow, the sprayer is operating between 1.4 MPa (14 bar) and 12 MPa (120 bar). A solid yellow pressure indicator means:

- The sprayer is at the proper pressure setting for spraying stain, lacquer, varnish, and multi-colors

**Solid Green**

When the pressure indicator is solid green, the sprayer is operating between 12 MPa (120 bar) and 23 MPa (230 bar). A solid green pressure indicator means:

- The sprayer is at the proper pressure setting for spraying oil-based and latex house paints
- The sprayer is operating at peak performance at a high pressure setting
- If the pressure indicator goes to solid yellow when the pressure is set so that it starts at solid green, it indicates one of the following:
  - a. **Tip Wear Indicator** — when spraying with latex or at high pressure the solid yellow appears. This means the tip is worn and needs to be replaced.
  - b. **Tip Too Large** — when a tip that is too large for the sprayer is put in the gun, the pressure indicator will turn from solid green to solid yellow.
  - c. **Fluid Section Wear** — if a solid yellow pressure indicator appears when using a new tip and the pressure is set at maximum, service may be required (worn packings, worn piston, stuck valve, etc...).

**4.3 PRESSURE CONTROL KNOB SETTINGS**

1. Minimum pressure setting
2. Black zone – no pressure generation
3. Blue zone – pulsating pressure for cleaning

⑥

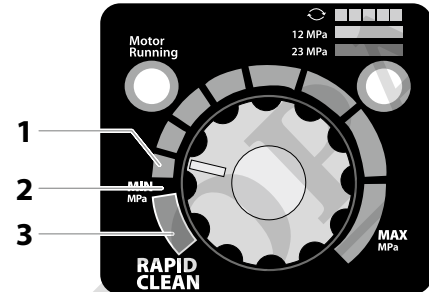
**4.4 CONNECTION TO THE MAINS NETWORK****Attention**

The unit must be connected to an appropriately-grounded safety outlet.

Before connecting the unit to the mains supply, ensure that the line voltage matches that specified on the unit's rating plate.

The connection must be equipped with a residual current protective device with  $INF \leq 30 \text{ mA}$ .



Titan's accessories program also includes a mobile operator protection device for the electronic supply, which can also be used with other electronic equipment.

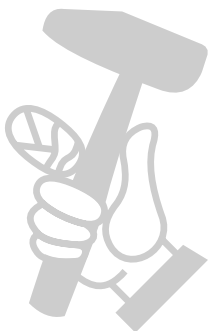

#### 4.5 CLEANING PRESERVING AGENT WHEN STARTING-UP OF OPERATION INITIALLY

1. Immerse the suction tube (Fig. 7, Item 2) return hose (1) into a container with a suitable cleaning agent.
2. Turn the pressure control knob counterclockwise (3) to minimum pressure.
3. Open the relief valve (4), valve position PRIME (↻ circulation).
4. Switch the unit (5) ON.
5. Wait until the cleaning agent exudes from the return hose.
6. Close the relief valve, valve position SPRAY (↗ spray).
7. Pull the trigger of the spray gun.
8. Spray the cleaning agent from the unit into an open collecting container.

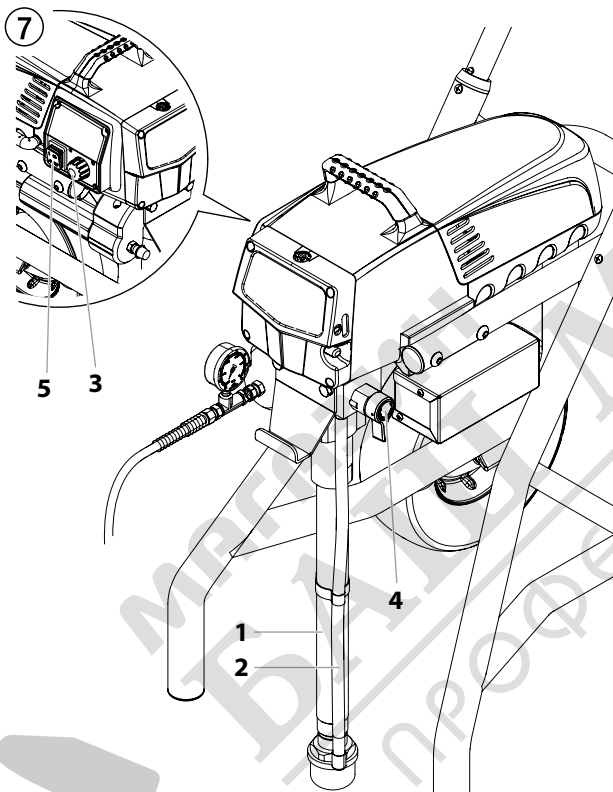

#### 4.6 TAKING THE UNIT INTO OPERATION WITH COATING MATERIAL

1. Immerse the suction tube (Fig. 7, Item 2) and return hose (1) into the coating material container.
2. Turn the pressure control knob counterclockwise (3) to minimum pressure.
3. Open the relief valve (4), valve position PRIME (↻ circulation).
4. Switch the unit (5) ON.
5. Wait until the coating material exudes from the return hose.
6. Close the relief valve, valve position SPRAY (↗ spray).
7. Trigger the spray gun several times and spray into a collecting container until the coating material exits the spray gun without interruption.
8. Increase the pressure by slowly turning up the pressure control knob.  
Check the spray pattern and increase the pressure until the atomization is correct.  
Always turn the pressure control knob to the lowest setting with good atomization.
9. The unit is ready to spray.

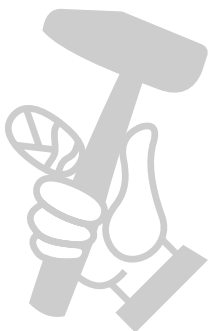

## 5 SPRAYING



Injection hazard. Do not spray without the tip guard in place. NEVER trigger the gun unless the tip is completely turned to either the spray or the unclog position. ALWAYS engage the gun trigger lock before removing, replacing or cleaning tip.

**A)** The key to a good paint job is an even coating over the entire surface. Keep your arm moving at a constant speed and keep the spray gun at a constant distance from the surface. The best spraying distance is 10-12 inches (25 to 30 cm) between the spray tip and the surface.

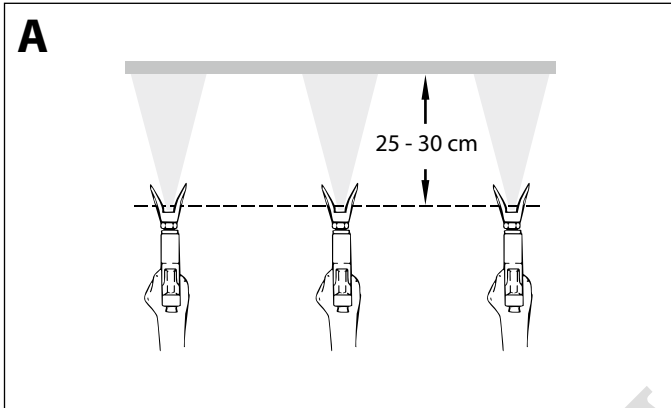

**B)** Keep the spray gun at right angles to the surface. This means moving your entire arm back and forth rather than just flexing your wrist. Keep the spray gun perpendicular to the surface, otherwise one end of the pattern will be thicker than the other.

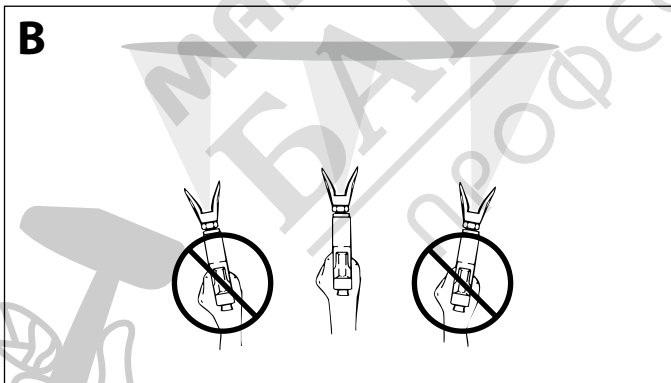

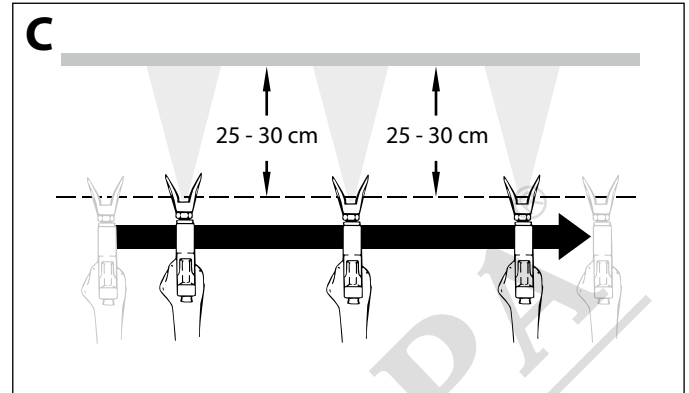

**C)** Trigger gun after starting the stroke. Release the trigger before ending the stroke. The spray gun should be moving when the trigger is pulled and released. Overlap each stroke by about 30%. This will ensure an even coating.



**i** If very sharp edges result or if there are streaks in the spray jet – increase the operating pressure or dilute the coating material.



## 6 HANDLING THE HIGH-PRESSURE HOSE



	The unit is equipped with a high-pressure hose specially suited for piston pumps.
	<p>Danger of injury through leaking high-pressure hose. Replace any damaged high-pressure hose immediately.</p> <p>Never repair defective high-pressure hoses yourself!</p>

The high-pressure hose is to be handled with care. Avoid sharp bends and folds: the smallest bending radius is about 8" (20 cm).

Do not drive over the high-pressure hose. Protect against sharp objects and edges.

Never pull on the high-pressure hose to move the device.

Make sure that the high-pressure hose cannot twist. This can be avoided by using a Titan spray gun with a swivel joint and a hose system.

	When using the high-pressure hose while working on scaffolding, it is best to always guide the hose along the outside of the scaffolding.
	The risk of damage rises with the age of the high-pressure hose. Titan recommends replacing high-pressure hoses after 6 years.
	Use only Titan original-high-pressure hoses in order to ensure functionality, safety and durability.



## 7 INTERRUPTION OF WORK

1. Open the relief valve, valve position PRIME (↻ circulation).
2. Switch the unit OFF.
3. Turn the pressure control knob counterclockwise to minimum pressure.
4. Pull the trigger of the spray gun in order to release the pressure from the high-pressure hose and spray gun.
5. Secure the spray gun, refer to the operating manual of the spray gun.
6. If a standard tip is to be cleaned, see Page 28, Section 12.2. If a non-standard tip is installed, proceed according to the relevant operating manual.
7. Depending on the model, leave the suction tube or the suction hose and return hose immersed in the coating material or swivel or immerse it into a corresponding cleaning agent.

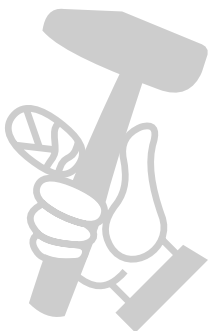

 Attention	If fast-drying or two-component coating material is used, ensure that the unit is rinsed with a suitable cleaning agent within the processing time.
--	---



## 8 CLEANING THE UNIT (SHUTTING DOWN)



	A clean state is the best method of ensuring operation without problems. After you have finished spraying, clean the unit. Under no circumstances may any remaining coating material dry and harden in the unit.
	The cleaning agent used for cleaning (only with an ignition point above 38 °C) must be suitable for the coating material used.
	<ul style="list-style-type: none"> <li>• <b>Secure the spray gun</b>, refer to the operating manual of the spray gun.</li> <li>• Clean and remove tip.</li> <li>• For a standard tip, refer to Page 28, Section 12.2.</li> <li>• If a non-standard tip is installed, proceed according to the relevant operating manual.</li> </ul>

1. Remove suction hose from the coating material.
2. Close the relief valve, valve position SPRAY (↗ spray).
3. Switch the unit ON.

 Attention	The container must be earthed in case of coating materials which contain solvents.
	Caution! Do not pump or spray into a container with a small opening (bunghole)!

4. Pull the trigger of the spray gun in order to pump the remaining coating material from the suction hose, high-pressure hose and the spray gun into an open container.
5. Immerse suction hose with return hose into a container with a suitable cleaning agent.
6. Turn the pressure control knob counterclockwise to minimum pressure.
7. Open the relief valve, valve position PRIME (↻ circulation).
8. Pump a suitable cleaning agent in the circuit for a few minutes.
9. Close the relief valve, valve position SPRAY (↗ spray).
10. Pull the trigger of the spray gun.
11. Pump the remaining cleaning agent into an open container until the unit is empty.
12. Switch the unit OFF.

### 8.1 CLEANING UNIT FROM OUTSIDE

	First of all pull out mains plug from socket.
 Attention	<p>Danger of short circuit through penetrating water!</p> <p>Never spray down the unit with high-pressure or high-pressure steam cleaners.</p> <p>Do not put the high-pressure hose into solvents. Use only a wet cloth to wipe down the outside of the hose.</p>

Wipe down unit externally with a cloth which has been immersed in a suitable cleaning agent.

### 8.2 SUCTION FILTER

	A clean suction filter always guarantees maximum feed quantity, constant spraying pressure and problem-free functioning of the unit.
---	--

1. Screw off the filter (Fig. 7) from suction tube.
2. Clean or replace the filter.

Carry out cleaning with a hard brush and an appropriate cleaning agent.

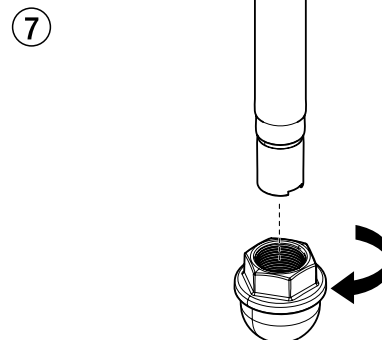

### 8.3 CLEANING THE HIGH-PRESSURE FILTER



Clean the filter cartridge regularly. A soiled or clogged high-pressure filter can cause a poor spray pattern or a clogged tip.

1. Turn the pressure control knob counterclockwise to minimum pressure.
2. Open the relief valve, valve position PRIME (↻ circulation).
3. Switch the unit OFF.



Unplug the power plug from the outlet.

4. Unscrew the filter housing (Fig. 8, Item 1) with a strap wrench.
5. Turning clockwise, unscrew the filter (2) from the pump manifold (3).
6. Clean all the parts with the corresponding cleaning agent. If necessary, replace the filter cartridge.
7. Check the O-ring (4), replace it if necessary.
8. Turning counterclockwise, screw the new or cleaned filter into the pump manifold.
9. Screw in filter housing (1) and tighten it as far as possible with the strap wrench.

⑧

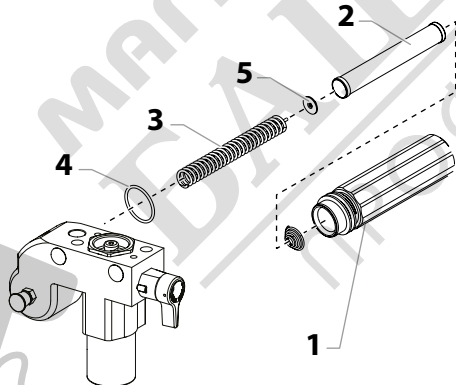

### 8.4 CLEANING AIRLESS SPRAY GUN



Clean the spray gun after each use.

1. Rinse airless spray gun with an appropriate cleaning agent.
2. Clean tip thoroughly with appropriate cleaning agent so that no coating material residue remains.
3. Thoroughly clean the outside of the airless spray gun.

#### INTAKE FILTER IN AIRLESS SPRAY GUN (FIG. 9)

1. Unclip the top of the trigger guard (1) from the gun head.
2. Using the bottom of the trigger guard as a wrench, loosen and remove the handle assembly (2) from the gun head.
3. Pull the old filter (3) out of the gun head. Clean or replace.
4. Slide the new filter, tapered end first, into the gun head.
5. Thread the handle assembly into the gun head. Tighten with the trigger wrench.
6. Snap the trigger guard back onto the gun head.

⑨

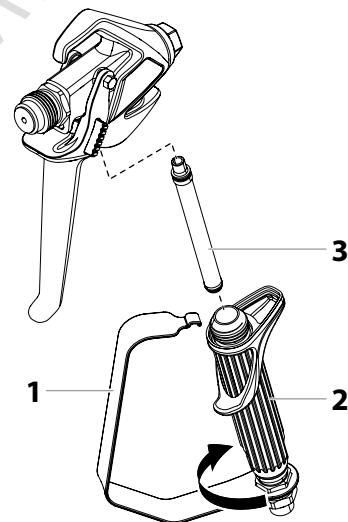

## 9 REMEDY IN CASE OF FAULTS

Type of malfunction	Possible cause	Measures for eliminating the malfunction
A. Unit does not start _____	<ol style="list-style-type: none"> <li>1. No voltage applied.</li> <li>2. Pressure setting too low.</li> <li>3. ON/OFF switch defective.</li> </ol>	<ol style="list-style-type: none"> <li>1. Check voltage supply.</li> <li>2. Turn up pressure control knob.</li> <li>3. Replace. _____</li> </ol>
B. Unit does not draw in material _____	<ol style="list-style-type: none"> <li>1. Relief valve is set to SPRAY (☞ spray).</li> <li>2. Filter projects over the fluid level and sucks air.</li> <li>3. Filter clogged.</li> <li>4. Suction hose/suction tube is loose, i.e. the unit is sucking in outside air.</li> </ol>	<ol style="list-style-type: none"> <li>1. Set relief valve to PRIME (☞ circulation).</li> <li>2. Refill the coating material.</li> <li>3. Clean or replace the filter.</li> <li>4. Clean connecting points. Replace O-rings if necessary. Secure suction hose with retaining clip.</li> </ol>
C. Unit draws in material, but the pressure does not build up _____	<ol style="list-style-type: none"> <li>1. Tip heavily worn.</li> <li>2. Tip too large.</li> <li>3. Pressure setting too low.</li> <li>4. Filter clogged.</li> <li>5. Coating material flows through the return hose when the relief valve is in the SPRAY (☞ spray) position.</li> <li>6. Packings sticky or worn.</li> <li>7. Valve balls worn.</li> <li>8. Valve seats worn.</li> </ol>	<ol style="list-style-type: none"> <li>1. Replace</li> <li>2. Replace tip.</li> <li>3. Turn pressure control knob clockwise to increase.</li> <li>4. Clean or replace the filter.</li> <li>5. Remove and clean or replace relief valve.</li> <li>6. Remove and clean or replace packings.</li> <li>7. Remove and replace valve balls.</li> <li>8. Remove and replace valve seats.</li> </ol>
D. Coating material exits at the top of the fluid section _____	<ol style="list-style-type: none"> <li>1. Upper packing is worn.</li> <li>2. Piston is worn.</li> </ol>	<ol style="list-style-type: none"> <li>1. Remove and replace packing.</li> <li>2. Remove and replace piston.</li> </ol>
E. Increased pulsation at the spray gun _____	<ol style="list-style-type: none"> <li>1. Incorrect high-pressure hose type.</li> <li>2. Tip worn or too large.</li> <li>3. Pressure too high.</li> </ol>	<ol style="list-style-type: none"> <li>1. Only use TITAN original-high-pressure hoses in order to ensure functionality, safety and durability.</li> <li>2. Replace tip.</li> <li>3. Turn pressure control knob to a lower number.</li> </ol>
F. Poor spray pattern _____	<ol style="list-style-type: none"> <li>1. Tip is too large for the coating material which is to be sprayed.</li> <li>2. Pressure setting incorrect.</li> <li>3. Volume too low.</li> <li>4. Coating material viscosity too high.</li> </ol>	<ol style="list-style-type: none"> <li>1. Replace tip.</li> <li>2. Turn pressure control knob until a satisfactory spraying pattern is achieved.</li> <li>3. Clean or replace all filters.</li> <li>4. Thin out according to the manufacturer's instructions.</li> </ol>
G. Unit loses power _____	<ol style="list-style-type: none"> <li>1. Pressure setting too low.</li> </ol>	<ol style="list-style-type: none"> <li>1. Turn pressure control knob clockwise to increase.</li> </ol>
H. Pump over-pressurizes and will not shut off. _____	<ol style="list-style-type: none"> <li>1. Pressure switch defective.</li> <li>2. Transducer defective.</li> </ol>	<ol style="list-style-type: none"> <li>1. Take unit to a Titan authorized service center.</li> <li>2. Take unit to a Titan authorized service center.</li> </ol>

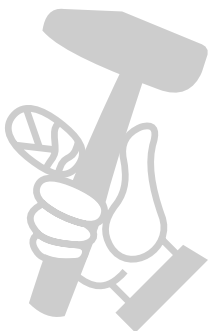

## 10 SERVICING

### 10.1 GENERAL SERVICING

Servicing of the unit should be carried out once annually by the TITAN service.

1. Check high-pressure hoses, device connecting line and plug for damage.
2. Check the inlet valve, outlet valve and filter for wear.

### 10.2 HIGH-PRESSURE HOSE

Inspect the high-pressure hose visually for any notches or bulges, in particular at the transition in the fittings. It must be possible to turn the union nuts freely.



The risk of damage rises with the age of the high-pressure hose. Titan recommends replacing high-pressure hoses after 6 years.

## 11 REPAIRS AT THE UNIT



Switch the unit OFF.

Before all repair work: Unplug the power plug from the outlet.



Make sure to check for grounding continuity after service is performed on any electrical components.

Use an ohmmeter to determine that there is continuity between accessible dead-metal parts of the product and the grounding blade of the attachment plug.

### 11.1 RELIEF VALVE



The valve housing (4) should not be repaired. If worn, it should always be replaced with a new one.

1. Use a drift punch of 2 mm to remove the grooved pin (Fig. 10, Item 1) from the relief valve handle (2).
2. Remove the relief valve handle (2) and cam base (3).
3. Using a wrench, remove the valve housing (4) from the pump manifold (6).
4. Ensure that the seal (5) is seated correctly, then screw the new valve housing (4) completely into the pump manifold (6). Tighten securely with a wrench.
5. Align the cam base (3) with the hole in the pump manifold (6). Lubricate the cam base with grease and slide on the cam base.
6. Bring the hole in the valve shaft (7) and in the relief valve handle (2) into alignment.
7. Insert the grooved pin (1) to secure the relief valve handle in position.

⑩

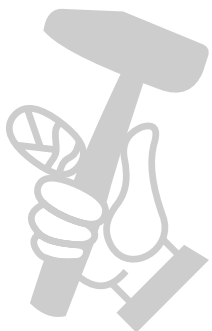
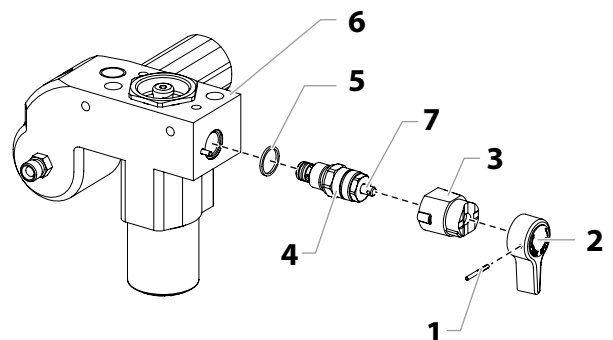

### 11.2 INLET AND OUTLET VALVE

1. Remove the four screws in the front cover and then remove the front cover.
2. Switch the unit ON and then OFF so that the piston rod is positioned in the lower stroke position.

	<p>Danger of crushing - do not reach with the fingers or tool between the moving parts.</p>
---	---

3. Unplug the power plug from the outlet.
4. **Unit on high-rider cart:**  
Screw off the suction tube.  
**Unit on stand:**  
Remove the retaining clip from the connecting bend at the suction hose and pull off the suction hose.
5. Screw off the return hose.
6. Swivel the unit 90° to the rear in order to work more easily on the material feed pump.
7. Unscrew the inlet valve housing (Fig. 11, Item 1) from the pump manifold.
8. Remove the lower seal (2), lower ball guide (3), inlet valve ball (4), inlet valve seat (5) and O-ring (6).
9. Clean all the parts with the corresponding cleaning agent.  
Check the inlet valve housing (1), inlet valve seat (5) and inlet valve ball (4) for wear and replace the parts if necessary. If the worn inlet valve seat (5) is unused on one side, install it the other way round.

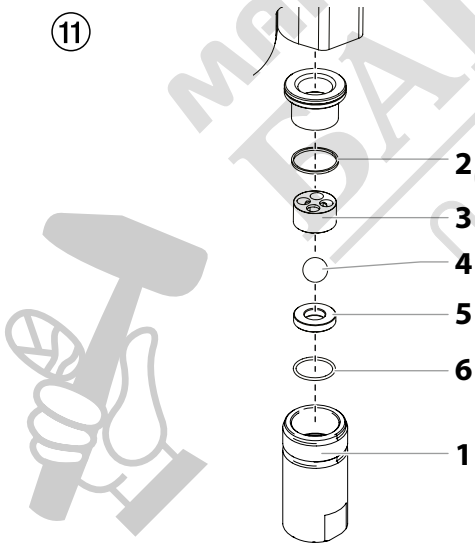

10. Unscrew outlet valve housing (Fig. 12, Item 8) from the piston (9) with adjusting wrench.
11. Remove the upper ball cage (11), crush washer (10), outlet valve ball (12), and outlet valve seat (13).
12. Clean all the parts with the corresponding cleaning agent. Check outlet valve housing (8), outlet valve seat (13), outlet valve ball (12), crush washer (10), and upper ball cage (11) for wear and replace parts if necessary. If the worn outlet valve seat (13) is unused on one side, install it the other way round.
13. Carry out installation in the reverse order. Lubricate O-ring (Fig. 11, Item 6) with machine grease and ensure proper seating in the inlet valve housing (Fig. 11, Item 1).

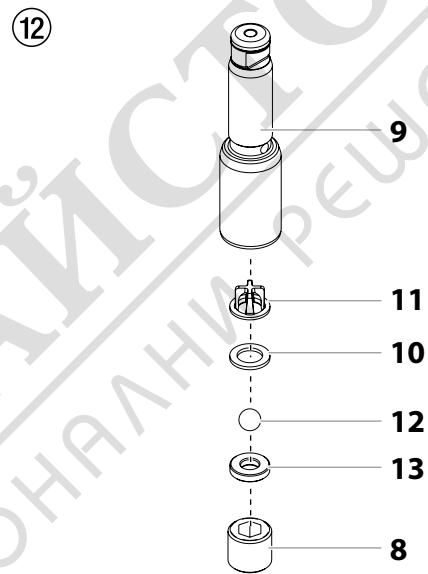

### 11.3 PACKINGS

1. Remove inlet valve housing in accordance with the steps in Chapter 11.2, Page 22.
2. It is not necessary to remove the outlet valve.
3. Unscrew both cylinder head screws (Fig. 13, Item 1) from the pump manifold (2) with a 3/8 inch hexagon socket head wrench.
4. Slide the pump manifold (2) and piston (3) forward until the piston is out of the T-slot (9) on the slider assembly (4).
5. Push piston (3) downward out of the pump manifold (2).
6. Unscrew retainer nut (5) from the pump manifold (2) and remove piston guide (6).
7. Remove upper packing (7) and lower packing (8) from the pump manifold (2).

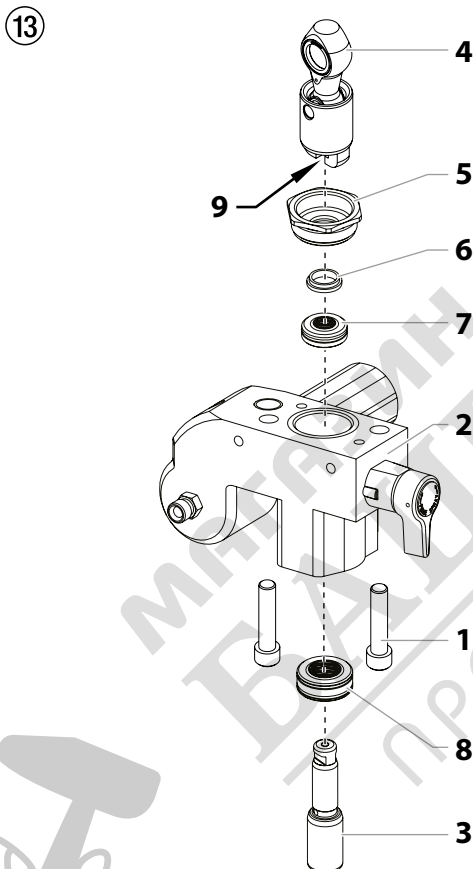

8. Clean pump manifold (2).
9. Lubricate upper packing (7) and lower packing (8) with machine grease.
10. Insert upper packing (Fig. 14) with O-ring (1) and protruding lip (2) downward.

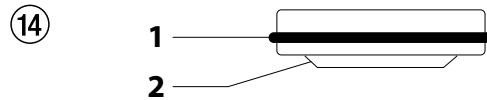

11. Insert lower packing (Fig. 15) with the beveled edge (1) facing upward.

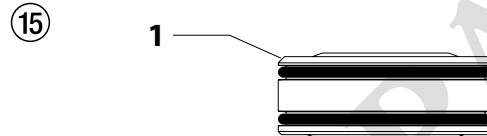

12. Insert piston guide (Fig. 13, Item 6) into the retainer nut (5). Screw retainer nut (5) into the pump manifold (2) and tighten by hand.
13. Push installation tool (included with the replacement packings) for the piston (3) from above onto the piston.
14. Lubricate installation tool and piston (3) with machine grease.
15. Guide piston (3) through the lower packings (8) into the pump manifold (2) from below. Using a rubber mallet, lightly tap the piston (3) from below until it can be seen above the pump manifold.
16. Remove installation tool from piston (3).
17. Carefully tighten retainer nut (5) with adjusting wrench.
18. Slide the top of the piston (3) into the T-slot (9) on the slider assembly (4).
19. Position the pump manifold (2) underneath the gear unit housing and push up until it rests against the gear unit housing.
20. Attach pump manifold (2) to the gear unit housing.
21. Screw pump manifold (2) tightly to gear unit housing.
22. Lubricate O-ring (Fig. 11, Item 6) between pump manifold (2) and inlet valve housing with machine grease. Screw inlet valve housing to the pump manifold.

**23. Unit on high-rider cart:**

Thread the siphon tube into the inlet valve and tighten securely. Make sure to wrap the threads on the down tube with PTFE tape before assembly. Replace the return hose into the hose clip on the siphon tube.

**Unit on stand:**

Insert the elbow on the siphon assembly into the bottom of the pusher stem housing. Push the retaining clip up into the groove inside the foot valve housing to secure the siphon assembly in position. Place the return tube over the return tube fitting and secure with the clip.

24. Install front cover.

## 11.4 REPLACING THE MOTOR



The following procedure must only be performed by a Titan Authorized Service Center.

1. Open the relief valve, valve position PRIME (↻ circulation). Switch the unit OFF. Unplug the power plug from the outlet.
2. Loosen and remove the two motor cover screws (fig. 16, item 1). Remove the motor cover (2).
3. Loosen and remove the three belly pan screws (3). Remove the belly pan (4).
4. On the back of the motor, disconnect the wire coming from the potentiometer and the wire coming from the transducer. Also, disconnect the two wires coming from the control panel board (refer to the electrical schematic in the Parts List section of this manual).
5. Remove the four control panel mounting screws (5). Pull back the control panel (6) for access to the control panel board.
6. At the the control panel board, disconnect the two wires coming from the motor (refer to the electrical schematic in the Parts List section of this manual).
7. Loosen and remove the four motor mounting screws (7).
8. Pull the motor (8) out of the pump housing.



If the motor will not dislodge from the pump housing:

- Remove the front cover plate.
- Using a rubber mallet, carefully tap on the front of the motor crankshaft that extends through the slider assembly.

9. With the motor removed, inspect the gears in the pump housing for damage or excessive wear. Replace the gears, if necessary.
10. Install the new motor (8) into the pump housing.
11. Secure the motor with the four motor mounting screws (7).
12. Reconnect the wires (refer to the electrical schematic in the Parts List section of this manual).
13. Position the control panel (6) on the pump housing and secure in position using the four control panel mounting screws (5).
14. Replace the belly pan (4). Secure with the three belly pan screws (3).
15. Slide the motor cover (2) over the motor. Secure the motor cover with the two motor cover screws (1).

16

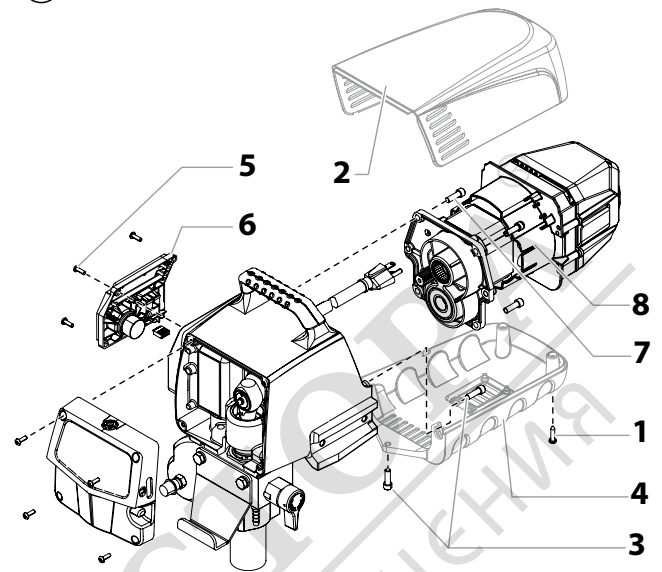



## 11.5 REPLACING THE GEARS



The following procedure must only be performed by a Titan Authorized Service Center.

1. Open the relief valve, valve position PRIME (↻ circulation). Switch the unit OFF. Unplug the power plug from the outlet.
2. Loosen and remove the two motor cover screws (fig. 17, item 1). Remove the motor cover (2).
3. Loosen and remove the three belly pan screws (3). Remove the belly pan (4).
4. On the back of the motor, disconnect the wire coming from the potentiometer and the wire coming from the transducer. Also, disconnect the two wires coming from the control panel board (refer to the electrical schematic in the Parts List section of this manual).
5. Remove the four control panel mounting screws (5). Pull back the control panel (6) for access to the control panel board.
6. At the the control panel board, disconnect the two wires coming from the motor (refer to the electrical schematic in the Parts List section of this manual).
7. Loosen and remove the four motor mounting screws (7).
8. Pull the motor (8) out of the pump housing.



If the motor will not dislodge from the pump housing:

- Remove the front cover plate.
- Using a rubber mallet, carefully tap on the front of the motor crankshaft that extends through the slider assembly.

9. Inspect the armature gear (9) on the end of the motor for damage or excessive wear. If this gear is completely worn out, replace the entire motor.
10. Remove and inspect the 2nd stage gear (10) for damage or excessive wear. Replace if necessary.
11. Remove and inspect the gear and crank assembly (11) for damage or excessive wear. Replace if necessary.
12. Reassemble the pump by reversing the above steps. During reassembly, make sure the thrust washer (12) is in place.

17

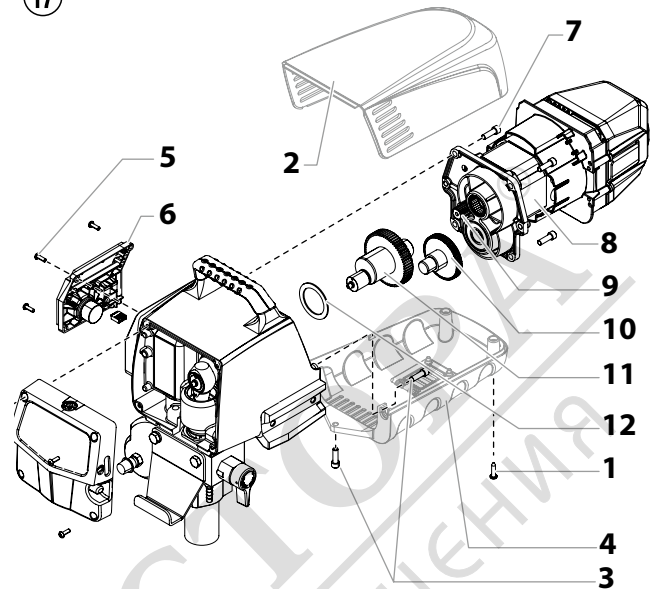

## 11.6 REPLACING THE TRANSDUCER



The following procedure must only be performed by a Titan Authorized Service Center.

1. Loosen and remove the four front cover screws (1). Remove the front cover (2).
2. Stop the sprayer at the bottom of its stroke so that the piston is in its lowest position.
3. Open the relief valve, valve position PRIME (↻ circulation). Switch the unit OFF. Unplug the power plug from the outlet.
4. Tilt the pump back for easy access to the fluid section.
5. Using a 3/8" hex wrench, loosen and remove the two pump block mounting screws (3).
6. Pull the pump block (4) down approximately 1/2" from the pump housing to clear the transducer (5).
7. Slide the pump block (4) and piston rod forward until the piston rod is out of the T-slot (6) on the slider assembly.
8. Carefully pull the transducer wire out of the pump housing (7) until the connection to the transducer jumper is exposed. Unplug the wire from the transducer jumper (refer to the electrical schematic in the Parts List section of this manual).
9. Using a wrench, remove the transducer assembly (5) from the pump block (4).
10. Thread the new transducer assembly into the pump block. Tighten securely with a wrench.
11. Plug the new transducer wire into the transducer jumper (refer to the electrical schematic in the Parts List section of this manual).
12. Reassemble the pump by reversing steps 1–7.

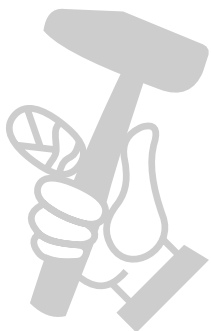
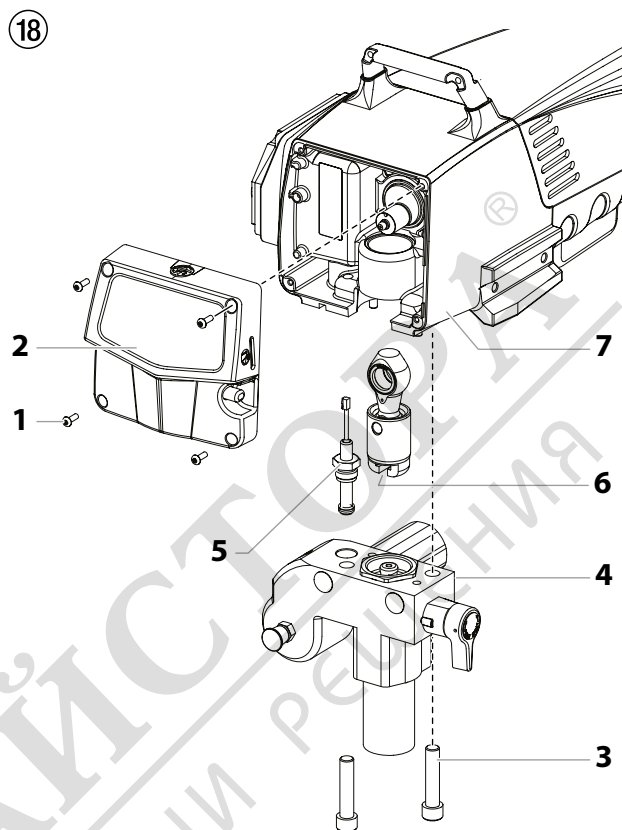

11.7 IMPACT 540 CONNECTION DIAGRAM

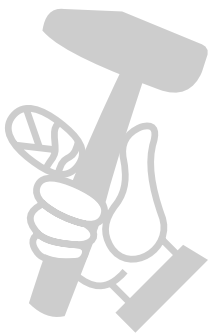
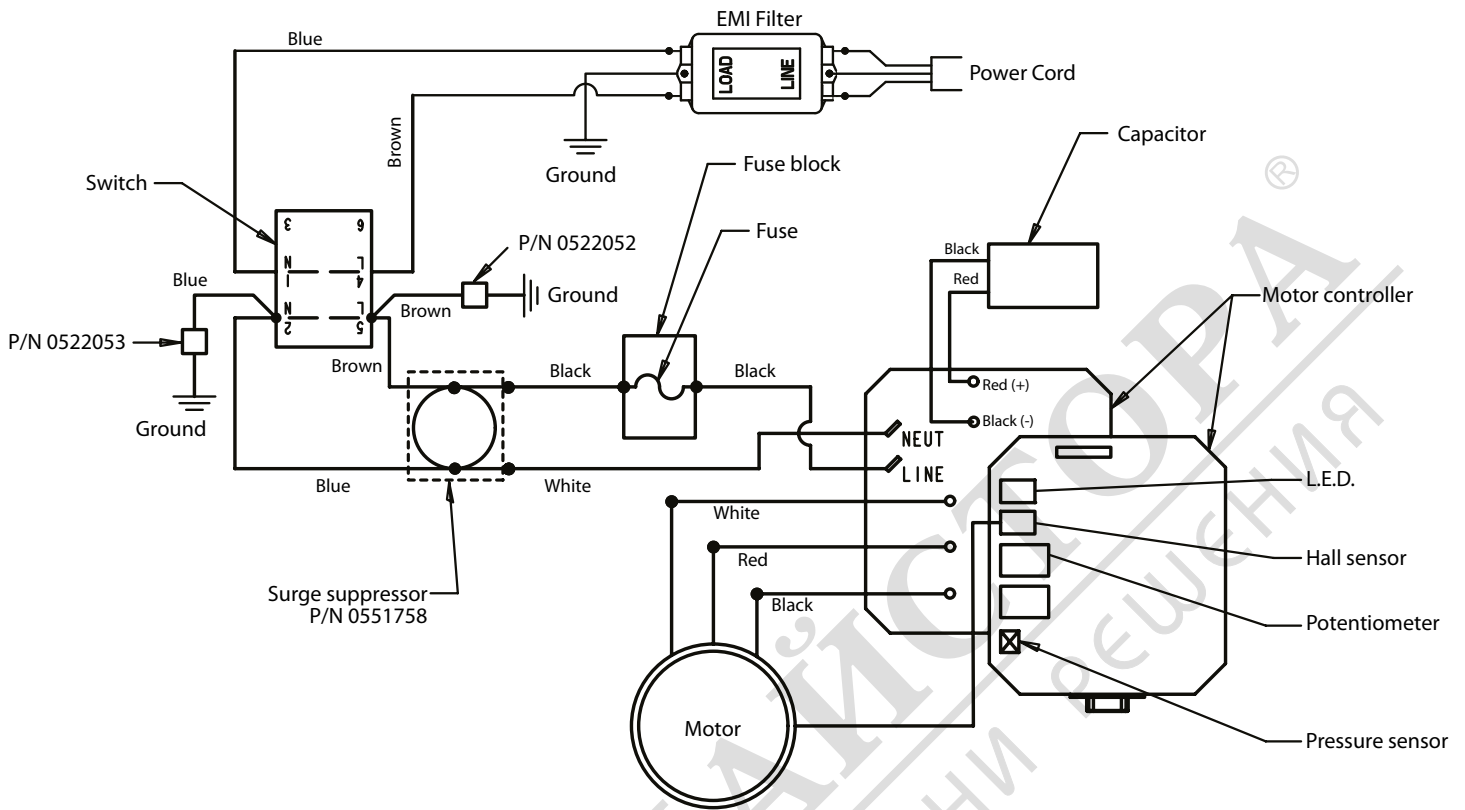



## WARRANTY

Titan Tool, Inc., ("Titan") warrants that at the time of delivery to the original purchaser for use ("End User"), the equipment covered by this warranty is free from defects in material and workmanship. With the exception of any special, limited, or extended warranty published by Titan, Titan's obligation under this warranty is limited to replacing or repairing without charge those parts which, to Titan's reasonable satisfaction, are shown to be defective within twelve (12) months after sale to the End User. This warranty applies only when the unit is installed and operated in accordance with the recommendations and instructions of Titan.

This warranty does not apply in the case of damage or wear caused by abrasion, corrosion or misuse, negligence, accident, faulty installation, substitution of non-Titan component parts, or tampering with the unit in a manner to impair normal operation.

Defective parts are to be returned to an authorized Titan sales/service outlet. All transportation charges, including return to the factory, if necessary, are to be borne and prepaid by the End User. Repaired or replaced equipment will be returned to the End User transportation prepaid.

THERE IS NO OTHER EXPRESS WARRANTY. TITAN HEREBY DISCLAIMS ANY AND ALL IMPLIED WARRANTIES INCLUDING, BUT NOT LIMITED TO, THOSE OF MERCHANTABILITY AND FITNESS FOR A PARTICULAR PURPOSE, TO THE EXTENT PERMITTED BY LAW. THE DURATION OF ANY IMPLIED WARRANTIES WHICH CANNOT BE DISCLAIMED IS LIMITED TO THE TIME PERIOD SPECIFIED IN THE EXPRESS WARRANTY. IN NO CASE SHALL TITAN LIABILITY EXCEED THE AMOUNT OF THE PURCHASE PRICE. LIABILITY FOR CONSEQUENTIAL, INCIDENTAL OR SPECIAL DAMAGES UNDER ANY AND ALL WARRANTIES IS EXCLUDED TO THE EXTENT PERMITTED BY LAW.

TITAN MAKES NO WARRANTY AND DISCLAIMS ALL IMPLIED WARRANTIES OF MERCHANTABILITY AND FITNESS FOR A PARTICULAR PURPOSE WITH RESPECT TO ACCESSORIES, EQUIPMENT, MATERIALS OR COMPONENTS SOLD BUT NOT MANUFACTURED BY TITAN. THOSE ITEMS SOLD, BUT NOT MANUFACTURED BY TITAN (SUCH AS GAS ENGINES, SWITCHES, HOSES, ETC.) ARE SUBJECT TO THE WARRANTY, IF ANY, OF THEIR MANUFACTURER. TITAN WILL PROVIDE THE PURCHASER WITH REASONABLE ASSISTANCE IN MAKING ANY CLAIM FOR BREACH OF THESE WARRANTIES.



**TITAN®**

**International**  
**international@titantool.com**

**Fax: 1-763-519-3509**

1770 Fernbrook Lane  
Minneapolis, MN 55447  
[www.titantool-international.com](http://www.titantool-international.com)

