



STANZEN



BOHREN



HEBEN



SÄGEN



ENTGRATEN

Bedienungsanleitung / Operation manual / Mode d'emploi / Manual de instrucciones /

ALFRA ROTABEST RB 35B

- DE** Metallkernbohrmaschine
- EN** Metal Core Drilling Machine
- FR** Perceuse à socle magnétique
- ES** Taladro electromagnético

Art-Nr. 18400 / Prod.-No. 18400 / N° de produit 18400 / N° de producto 18400



Dear customer,

Thank you for purchasing an ALFRA product. Be sure to read these operation instructions closely before using your device for the first time and keep them along with the enclosed Product Control Card for later reference.

Safety Instructions

Danger can occur when working with this machine due to improper handling and/or poor maintenance, which may lead to the destruction of the device and to severe physical injuries. Observe all safety instructions of this operating manual and contact our Service Team if you have any questions.

Always...



- activate the magnet on metallic, ferromagnetic materials
- use the whole magnetic surface for working
- work on plane surfaces



- clean the magnetic surface and keep it clear of dirt, swarf and welding spatter
- set the core drilling machine down gently to prevent damage to the magnetic surface
- secure yourself with a safety belt when drilling on walls or ceilings
- check connection cables for damage



- make sure the mains voltage matches the machine
- follow the instructions in these operation instructions
- familiarise new users with the safe use of the machine



- wear safety goggles and ear protection during work
- use safety guard if supplied
- observe local, country-specific guidelines
- store in a dry place

Never...



- work on round or curved objects
- drill several work pieces on top of one another
- modify the core drilling machine or remove signs



- use the core drilling machine when damaged or when parts are missing
- strain or damage the underside of the magnet through heavy impact or blows
- use the core drilling machine without having been properly instructed



- operate the machine without having read and understood the complete operating manual
- use the core drilling machine to support, lift or transport persons or loads
- carry out electric welding work on the work piece at the same time as using the core drilling machine



- store or operate the core drilling machine at temperatures above 50°C (122°F)
- leave the machine hanging unsupervised
- allow the machine to come into contact with corrosive materials



People with cardiac pacemakers or other medical appliances may only use this machine following approval by their physician.



Never touch rotating parts! Keep hands and fingers away from the work area while the motor is running! Failure to do so can result in severe injuries!

Specified Conditions of Use

This machine is destined to cut material with magnetisable surface with core cutters and twist drills in sheltered environment for commercial use in industry and craft. The device is suitable for drilling vertical, horizontal and overhead.

Technical Data

Prod.-No. and description:	18400 Rotabest RB 35B	
Input:	1100 Watt	
On-load speed:	450 rpm	
Tool holder:	19 mm Weldon adapter	¾" Weldon adapter
Coolant supply:	internal	
Voltage: (See nameplate)	230 V 50/60 Hz	110 V 50/60 Hz
Magnetic adhesion:	9000 N	
Tool force (on 10 mm steel):	2100 N	
Boring Ø max. in steel		
- Core cutter:	12 - 35 mm	½" - 1 ¾"
- Twist drills:	1 - 6 mm DIN 338 6 -13 mm DIN 1897	1/16" - ¼" ¼" - ½"
Counterbore:	Ø 10 – 40 mm	Ø 3/8" – 1 9/16"
Cutting depth:	50 mm	2"
Stroke:	120 mm	4.72"
Size of magnetic base:	70 x 185 mm	2.76" x 7.28"
Weight:	10.6 kg	23.3 lbs
Noise emission:	92 dB(A) @ 300 mm distance from the motor	92 dB(A) @ 12" distance from the motor
Vibration on the handle:	AC=3,5 mm/s ² and VC=3,2 mm/s	

Available Accessories

	Prod.-No.
• Transport case	17701
• Coolant unit	189311241
• Coolant spray ALFRA BIO 4000	21040
• Safety guard	189311293 + 2x 189601096
• Safety belt	189490501
• Allen key 2,5 mm	DIN911-2,5
• Allen key 4,0 mm	DIN911-4,0
• Swarf remover	189480022

Description

The Magnetic Core Drilling Machine can be fixed with a switchable electromagnet on ferromagnetic work pieces. The electromagnet (C) and the motor (A) can be switched on and off with the large buttons of the control panel (E). A self-adjusting dovetail guide on which the motor is mounted can be adjusted in height with the star handle (F). On the back of the machine is the nameplate including the serial number.

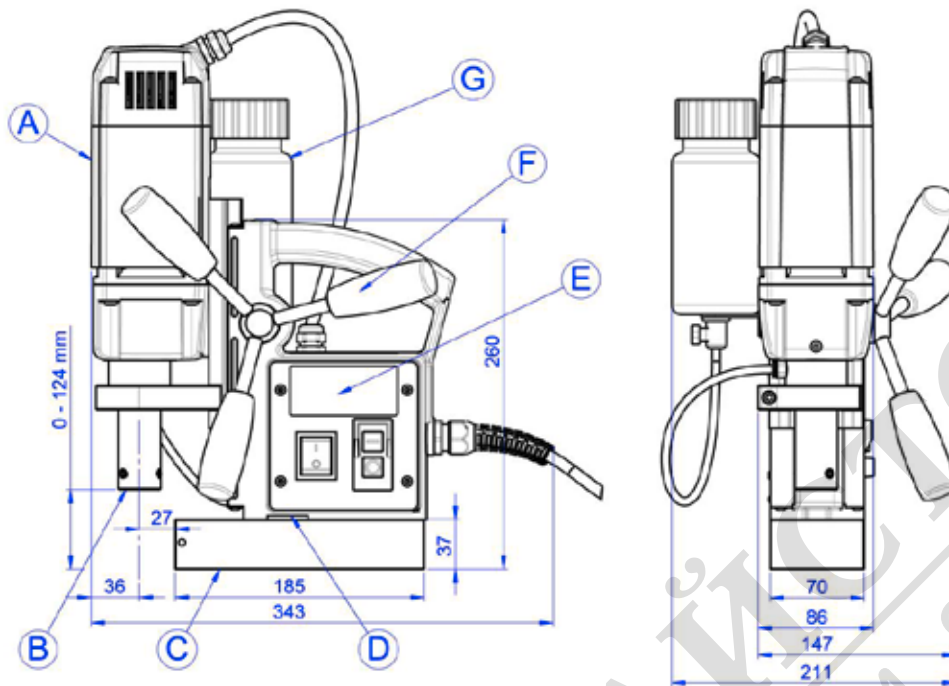

- A) Motor
- B) Weldon-Arbor
- C) Magnetic base
- D) Recess for safety belt

- E) Control panel
- F) Star handle
- G) Coolant unit

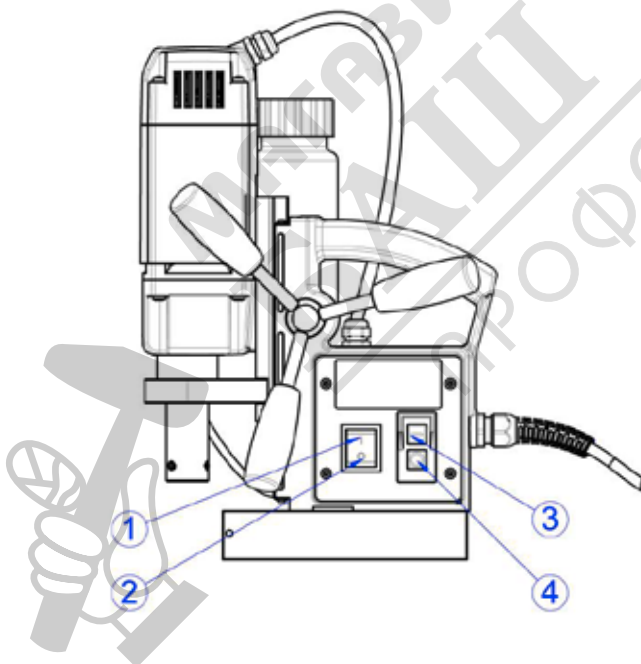

- 1 – Magnet ON
- 2 – Magnet OFF
- 3 – Motor ON
- 4 – Motor OFF

Start-up

You receive a completely assembled Magnetic Core Drilling Machine and detailed operating manual. Please check the condition of the goods on receipt for any transport damage, and make sure the delivery is complete. Otherwise contact the manufacturer or distributor immediately.



Always read the operating manual before using the device for the first time!

1. First check cable and connector for damages, then plug in the power plug.
2. Insert the annular cutter into the tool holder on the working spindle of the motor and check the rigid and precise clamping of the tool.
3. Press the switch **MAGNET ON (1)** to activate the magnet and ensure holding of the drill stand.
 - Secure the drilling machine by means of a safety chain when working on walls and ceilings. During this work we recommend using a coolant spray (Alfra BIO 4000, prod.-no. 21040).
4. Switch the motor on by operating the switch **MOTOR ON (3)**.
5. Slowly guide the motor and the rotating cutter to the tool by turning the star handle. Take special care of sufficient cooling during the drilling process.
6. Once the drilling operation is completed move the motor upwards by turning the star handle. Switch the motor off by pressing the red button **MOTOR OFF (4)** on the control panel.
7. After the motor has come to a complete standstill remove swarf and the remaining drill cuttings.
8. Operate the switch **Magnet OFF (2)** to deactivate the magnet.
9. Now clean the magnetic surface and remove swarf or any other adhering residues.

Working with Annular Cutters

- Push centring and ejecting pin through head of annular cutter.
- Core drills with Weldon shank are tightened with clamping screws (DIN 913) on both clamping surfaces.

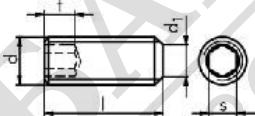

- First place centring and ejecting pin on a marked centre or marking.
- Set the cutter and spot-drill, until the entire cut edge is formed as a circle.
- During the drilling process, the cutter should be cooled permanently. Optimal cooling is possible by internal cooling with our coolant unit.
- During the drilling process, do not stop the motor. After the process, cutter draws back with running motor.
- Remove chips and core after each drilling.



Remove swarf with swarf remover. Do not touch with bare hands. Danger of injury!

Working with Twist Drills

- The drill chuck with Weldon shank is only to be used with twist drills up to a diameter of 13 mm.
- Insert drill chuck with adaptor in the drill spindle.
- Insert twist drill in drill chuck and tighten.

Maintenance and Inspection

The user is obliged to maintain and service the core drilling machine in compliance with the specifications in the operating manual and according to the country-specific standards and regulations.

The maintenance intervals are classified according to the frequency with which the maintenance should be carried out.



Always disconnect the machine from the mains before any maintenance operation and repairs, otherwise there is a risk of injury due to unintentional machine switch-on.

Before every use...

- inspect the core drilling machine and underside of the magnet for visible signs of damage
- clean the surface of the work piece and the underside of the magnet
- check the correct, firm fit of the core drill
- check connection cables for damage

Weekly...

- use dry compressed air to blow the motor compartment out from the outside

Monthly...

- check the markings and labelling on the core drilling machine for legibility and damage. Replace them if necessary
- clean all the sliding surfaces regularly, re-lubricate them and set the pre-tension of the slide

Annually...

- replace the gear oil or gear grease
- replace the carbon brushes after about 250 operating hours

Maintenance, testing and repair work may only be carried out by qualified electricians according to the regulations valid in the respective country.

Only use original ALFRA spare parts.

View our detailed spare parts list at the end of this operating manual.

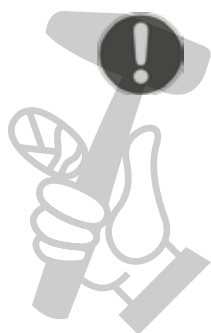

EC Declaration of Conformity

Herewith we,

Alfred Raith GmbH
2. Industriestr. 10
68766 Hockenheim

declare that the metal core drilling machine

ALFRA Rotabest RB 35B

corresponds to the following directives:

Machinery Directive: 2006/42/EC
Low Voltage Directive: 2006/95/EC
Electro-magnetic compatibility (EMC): 2004/108/EC
RoHs Directive: 2011/65/EU

Following directives or normative documents were applied:

Machinery Directive:
EN 12348:2000+A1:2009
EN 61029-1:2009

Low Voltage Directive:
EN 60204-1:2006+A1:2009
EN 60034-1:2010
EN 60034-5:2001+A1:2007

EMC Directive:
EN 55014-1:2006+A1:2009+A2:2011
EN 55014-2:1997+A1:2001+A2:2008
EN 61000-3-2:2006+A1:2009+A2:2009
EN 61000-3-3:2008

RoHs Directive:
EN 50581:2012

Authorized for the compilation of the documents:

Alfred Raith GmbH
2. Industriestr. 10
68766 Hockenheim, Germany

Hockenheim, 18.02.2016



Markus A. Döring
(Managing Director)

Passende Produkte für Ihre Anwendung / Suitable products for your application / Des produits adaptés à votre application / Los productos adecuados para su aplicación

Stanzen und Bohren / Punching and Drilling / Poinçonner et percer / Punzonar y taladrar



Akku-Compact Flex™



ROTABEST RB 35 SP

Heben / Lifting / Lever / Elevar



TMH 50



TML 250

Schneiden / Cutting / Couper / Tajar

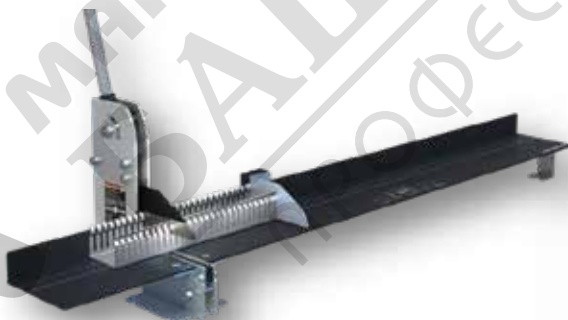

VKS 125



PSG4

Wenn Sie mehr über diese oder andere Produkte erfahren möchten, fragen Sie Ihren ALFRA-Händler oder besuchen Sie uns auf unserer Homepage, auf Facebook oder auf YouTube.

For more information on these or further products, contact your ALFRA distributor or visit our homepage. Follow us on Facebook and YouTube.

Pour plus d'informations sur nos produits, contactez votre distributeur ALFRA ou consultez notre site web. Suivez-nous sur Facebook ou YouTube.

Para más información sobre nuestros productos, pregunte a su ALFRA distribuidor o visite nuestro sitio web. Sigán-lase en el nuestro Facebook o YouTube.

www.alfra.de

www.youtube.com/user/alfratools

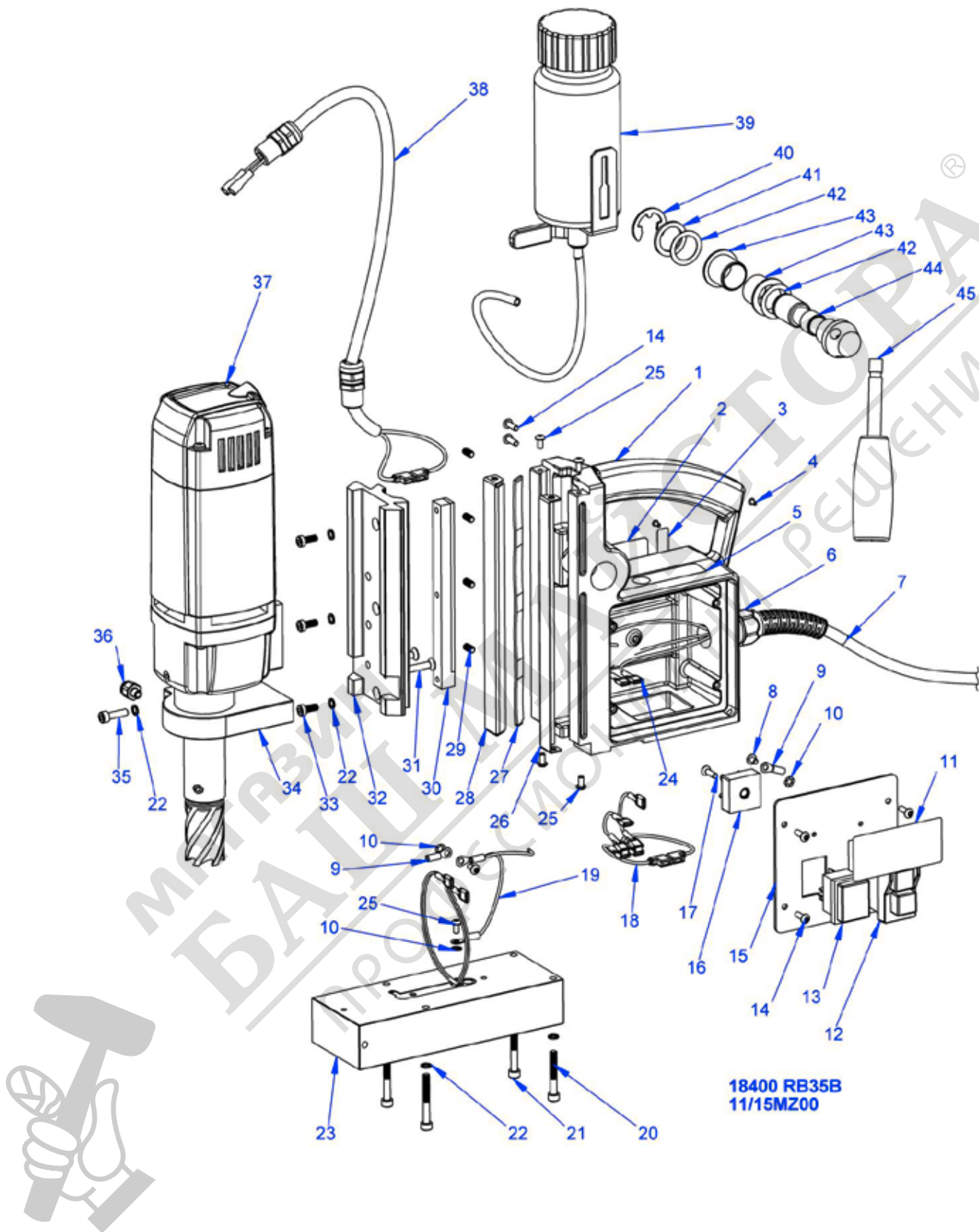

Pos. Pos.	Menge Qty.	Art.-Nr. Prod.-No.	Beschreibung	Description	Description	Descripción
1	1	189412076	Ständergehäuse RB 35X	housing RB 35X	châssis RB 35X	carcasa RB 35X
2	1	189412090	Typenschild RB 35B	name plate RB 35B	plaque d'identification RB 35B	placa de características RB 35B
3	1	189412091	Aufkleber	label	autocollant	adhesivo
4	4	DIN1476-M2,5x8,0	Kerbnagel	grooved drive stud	clou cannelé	remache estriado
5	1	189412186	Aufkleber "Made in Germany"	label "Made in Germany"	autocollant « Made in Germany »	adhesivo "Made in Germany"
6	1	189490604	Knickschutzhülse	protection sleeve	protection de fils électriques	tubo de protección del cable
7	1	189412071	Kabel mit Stecker	supply cable with plug	câble et prise	cable con conector
8	2	ISO7380-M4X8-10.9	Flachrundschrabe	round head screw	vis à tête bombée	tornillos de cabeza redonda
9	3	189-05589011	Kabelverbinder	cable connector	cosse de câble	conector de cables
10	2	189070005	Zahnscheibe	toothed lock washer	disque denté	arandela dentada
11	1	189412092	Frontaufkleber RB 35B	front label RB 35B	autocollant frontal RB 35B	adhesivo frontal RB 35B
12	1	189411057	Motorschalter	motor switch	interrupteur moteur	commutador del motor
13	1	189411056	Magnetschalter	magnet switch	interrupteur soci. magn.	Commutador del imán
14	6	ISO7380-M4X12-10.9	Flachrundschrabe	round head screw	vis à tête bombée	tornillos de cabeza redonda
15	1	189412088	Schalterplatte RB 35B	switch plate RB 35B	plaque pour interrupteur RB 35B	plancha para conmutadores RB 35B
16	1	189411058	Brückengleichrichter	bridge rectifier	redresseur à pont	punteo rectificador
17	1	DIN7991-M4x14-10.9	Senkkopfschraube	countersunk head cap screw	vis à tête fraisée	tornillo
18	1	189412107	Kabel Steuerkasten	cable for control box	câble pour boîtier de contrôle	cable para caja de control
19	1	3063	Kabel	cable	câble	cable
20	1	DIN912-M5X35-8.8	Zylinderschraube	hexagon socket screw	vis à tête cylindrique	tornillo cilíndrico
21	3	DIN912-M5X40-8.8	Zylinderschraube	hexagon socket screw	vis à tête cylindrique	tornillo cilíndrico
22	7	DIN7980-5-ST	Federring	spring washer	rondelle élastique	arandela de muelle
23	1	189412001A.230V	Magnetfuß RB 35X 230 Volt	magnetic base RB 35X 230 Volt	socle magnétique RB 35X 230 V	imán RB 35X 230 voltios
23	1	189412001A.110V	Magnetfuß RB 35X 110 Volt	magnetic base RB 35X 110 Volt	socle magnétique RB 35X 110 V	imán RB 35X 110 voltios
24	10	189-055890511	Flachsteckhülse	blade receptacle	cosse plate femelle	hembra de enchufe plano
25	4	ISO7380-M4X8-10.9	Flachrundschrabe	round head screw	vis à tête bombée	tornillos de cabeza redonda
26	1	189412062	Messingprofil -rechts-	brass profile -right-	profil laiton -droite-	perfil de latón -derecho-
27	1	189414084	Federblech	spring steel plate	tôle souple	chapa para láminas de contacto
28	1	189412063	Messingprofil -links-	brass profile -left-	profil laiton -gauche-	perfil de latón -izquierdo-
29	4	DIN913-M5X10-45H-TF	Gewindestift -Tuflok-	set screw -Tuflok-	vis sans tête -Tuflok-	espiga roscada -Tuflok-
30	1	189301003	Zahnstange	rack	crémaillère	cremallera
31	2	DIN7991-M5x20-8.8	Senkkopfschraube	countersunk head cap screw	vis à tête fraisée	tornillo
32	1	189412089	Schlitten	slide	glissoir	carro
33	3	DIN6912-M5X16-8.8	Zylinderschraube	hexagon socket screw	vis à tête cylindrique	tornillo cilíndrico
34	1	189302038	Motorhalterung / Spannbock	motor support / fixing block	support de moteur / pièce de fixation	soporte del motor / elemento de fijación
35	1	DIN912-M5x20-8.8	Zylinderschraube	hexagon socket screw	vis à tête	tornillo cilíndrico
36	1	189401059	Schlauchkupplung	hose connection	coupleur	acople
37	1	18221	Motor MBN 13 IA X (230 Volt)	motor MBN 13 IA X (230 Volt)	moteur MBN 13 IA X (230 volt)	motor MBN 13 IA X (230V)
37	1	18221.110	Motor MBN 13 IA X (110 Volt)	motor MBN 13 IA X (110 Volt)	moteur MBN 13 IA X (110 volt)	motor MBN 13 IA X (110V)
38	1	189412106	Kabel Basic Line	cable Basic Line	câble Basic Line	cable Basic Line
39	1	189311241	Kühlmittelbehälter (kpl.)	coolant unit (compl.)	réservoir de produit réfrigérant (compl.)	recipiente del refrigerante (compl.)
40	1	DIN6799-D15,0	Sicherungsscheibe	lock washer	clip d'arrêt	anillo de seguridad
41	1	DIN988-20X28X0,5	Passscheibe	washer	rondelle	arandela de ajuste
42	2	DIN988-20X28X2,0	Passscheibe	washer	rondelle	arandela de ajuste
43	2	189301014	Gleitlager	plain bearing	palier lisse	cojinete de deslizamiento
44	1	189301015	Ritzelwelle	pinion shaft	arbre de pignon	arbol del piñón
45	3	189301074	Speichen	spokes	moyeux	rayos des torniquete



Alfred Raith GmbH
Hockenheim

Ersatzteilliste

MBN 13 IA X

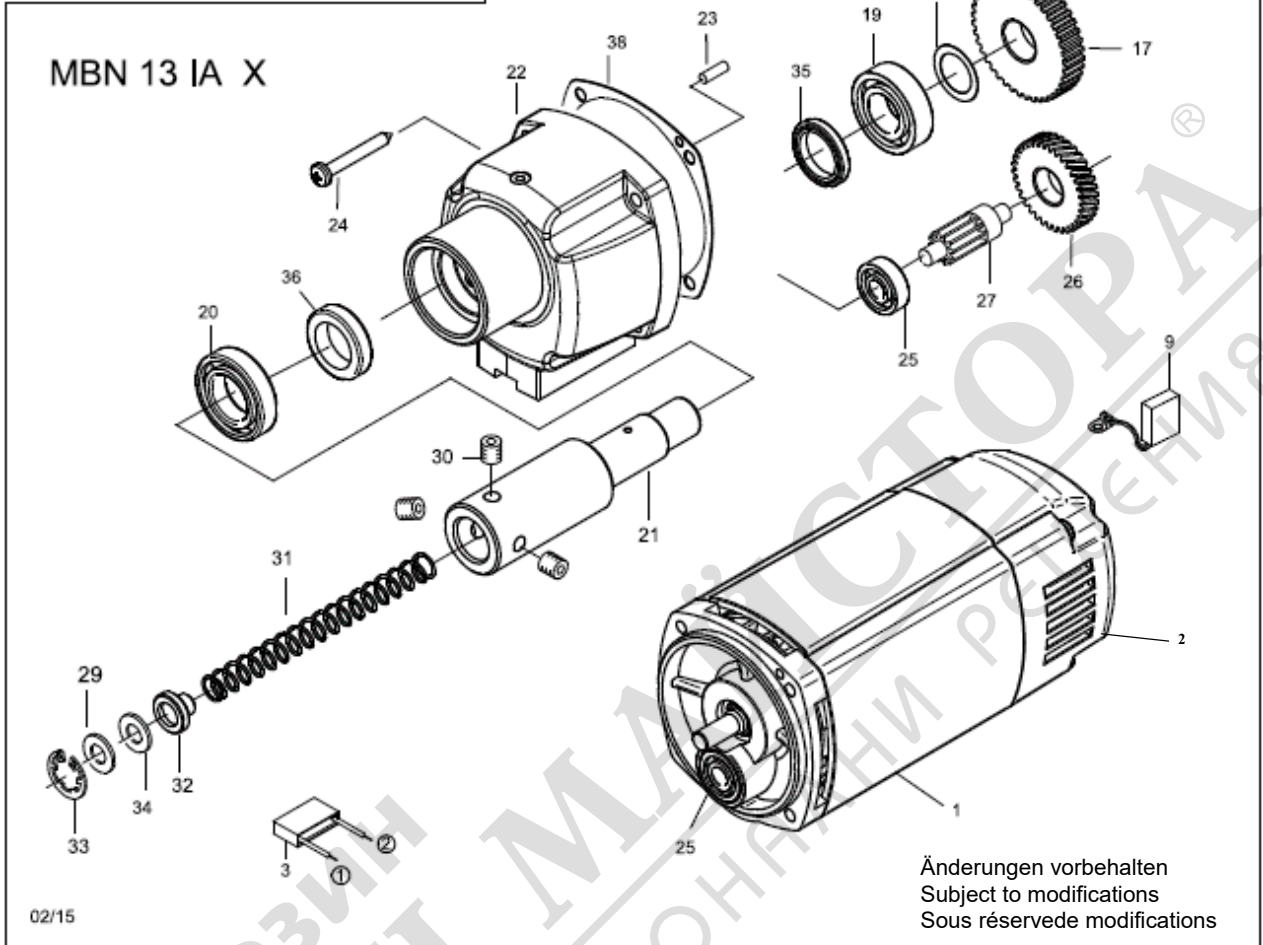

Änderungen vorbehalten
Subject to modifications
Sous réserve modifications

02/15

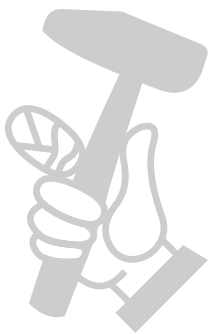

Pos.	Menge Qty.	Art.-Nr. Prod.-No.	Beschreibung	Description	Description
1	1	189401099	Motor 230 Volt (ohne Getriebe)	Motor (w/o gear) 230 Volt	Moteur 230 volt (sans boîte de vitesse)
1	1	189401099.110	Motor 110 Volt (ohne Getriebe)	Motor (w/o gear) 110 Volt	Moteur 110 volt (sans boîte de vitesse)
2	1	189401100	Motorkappe	cap for motor housing	couvercle du moteur
3	1	189502065	Entstörkondensator	anti-interference capacitor	condensateur d'antiparasitage
9	2	189502054	Kohlebürste (230V)	carbon brush (230V)	charbon (230 V)
9	2	189502054.110	Kohlebürste (110V)	carbon brush (110V)	charbon (110 V)
17	1	189302017	Spindelrad	spindle gear	pignon
18	1	189302018	Passscheibe	washer	rondelle
19	1	189302019	Rillenkugellager	deep groove ball bearing	roulement à bille
20	1	189302020	Rillenkugellager	deep groove ball bearing	roulement à bille
21	1	189302209	Arbeitsspindel	motor spindle	broche
22	1	189401096	Getriebegehäuse	gear box	carter de la boîte de vitesse
23	1	189502011	Kerbstift	dowel pin	goupille cannelée
24	4	189302024	Blechschaube	tapping screw	vis à tôle
25	2	189502037	Rillenkugellager	deep groove ball bearing	roulement à bille
26	1	189302026	Zwischenrad	gear block	pignon
27	1	189302027	Ritzelwelle	pinion shaft	arbre de pignon
29	1	189622052	Passscheibe	washer	rondelle
30	3	DIN913-M8X8-45H	Gewindestift	set screw	vis HC
31	1	189302207	Druckfeder	pressure spring	ressort de rappel
32	1	189302208	Federhalterung	spring attachment	butée
33	1	189621037	Sicherungsring	retaining ring	circlip extérieur
34	1	189502064	Gummiring	sealing ring	joint torique
35	1	189302035	Wellendichtring	shaft sealing ring	joint à lèvres avec ressort
36	1	189502031	Wellendichtring	shaft sealing ring	joint à lèvres avec ressort
37	1	189502064	Gummiring	sealing ring	joint torique
38	1	189302051	Getriebedichtung	gear sealing	joint à boîte de vitesse

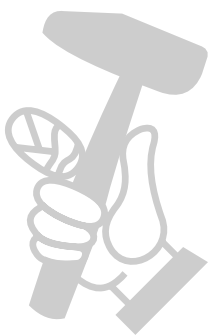

МАГАЗИН
БАШ МАЙСТОРА[®]
ПРОФЕССИОНАЛНИ РЕШЕНИЯ

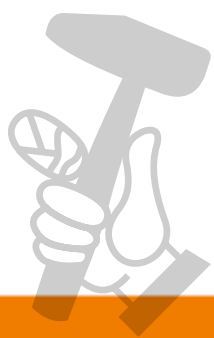

Stand 02/2016



www.alfra.de