

de	Originalbetriebsanleitung - Absaugmobil	7
en	Original operating manual - Mobile dust extractors	13
fr	Notice d'utilisation d'origine - Aspirateurs mobile	19
es	Manual de instrucciones original - Sistemas móviles de aspiración	26
it	Istruzioni per l'uso originali - Unità mobili d'aspirazione	33
nl	Originele gebruiksaanwijzing - Mobiele afzuigapparaten	40
sv	Originalbruksanvisning - Dammsugare	46
fi	Alkuperäiset käyttöohjeet - Siirrettävät imurit	52
da	Original brugsanvisning - Støvsugere	58
nb	Originalbruksanvisning - Mobil støv-/våtsuger	64
pt	Manual de instruções original - Aspiradores móveis	70
ru	Оригинал Руководства по эксплуатации - Пылеудаляющие аппараты	76
cs	Originál návodu k obsluze - Mobilní vysavače	83
pl	Oryginalna instrukcja eksploatacji - Odkurzacze mobilne	89
zh	原版使用说明书	96
ko	원본 사용자 설명서	101

CTL MINI I CTL MIDI I CTL MINI CTL MIDI

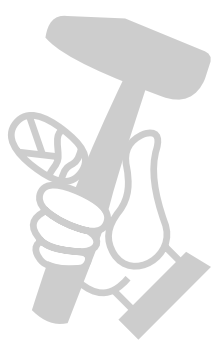

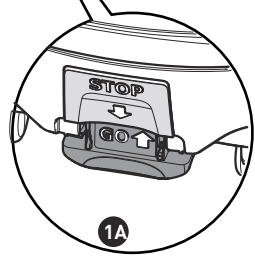
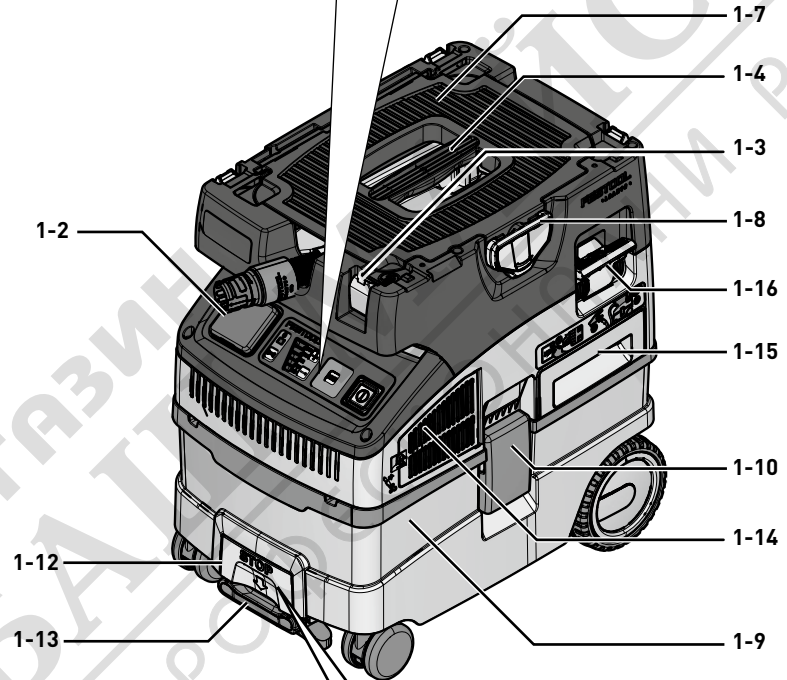
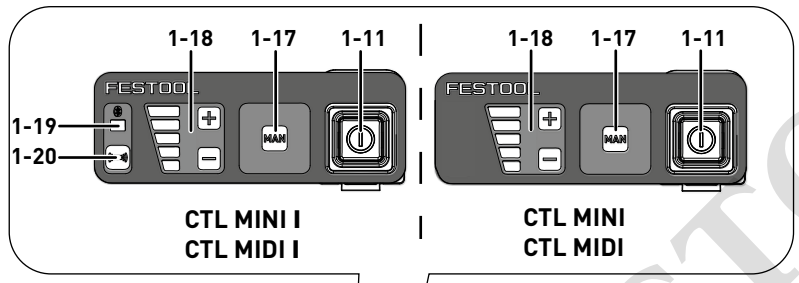

МАГАЗИН
БАЛТИЙСКОГО
ПРОЕКТА
РЕШЕНИЯ

МАГАЗИН
БАЛТИЙСКОГО
ПРОЕКТА
РЕШЕНИЯ

2

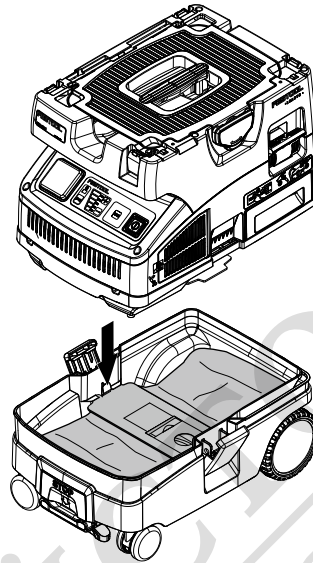
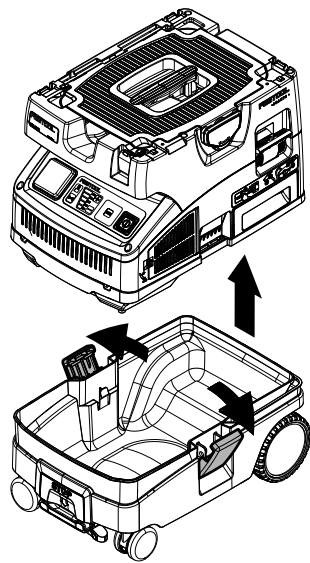

3

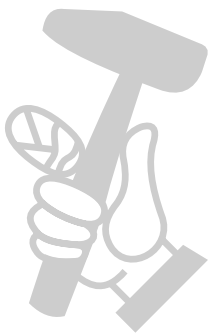
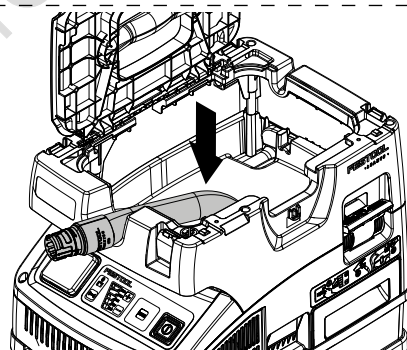
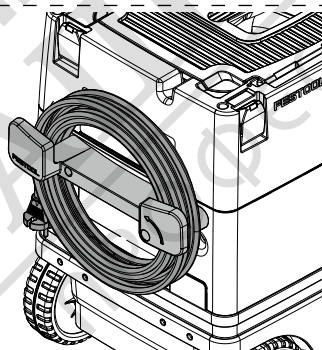
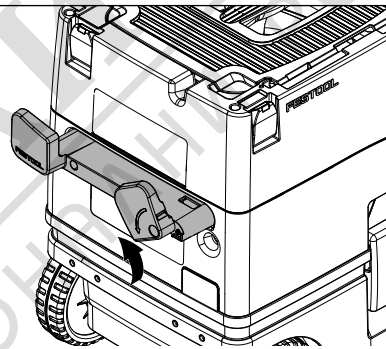
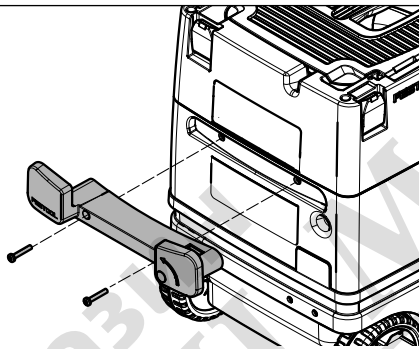

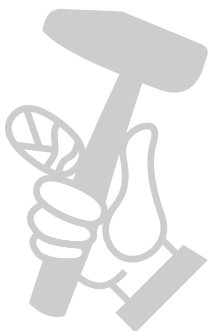
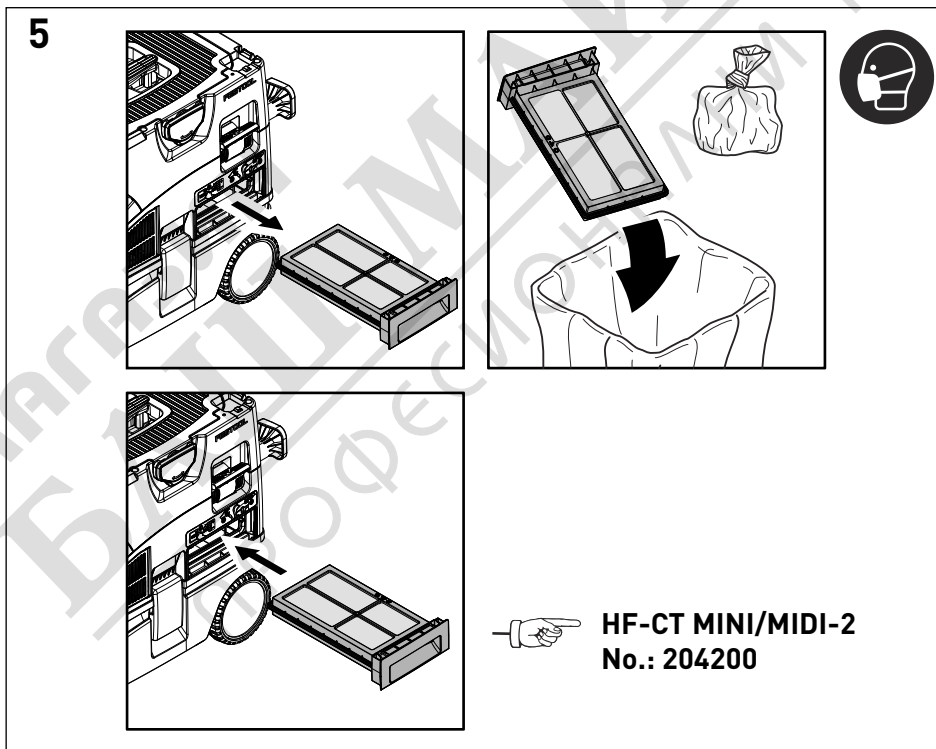
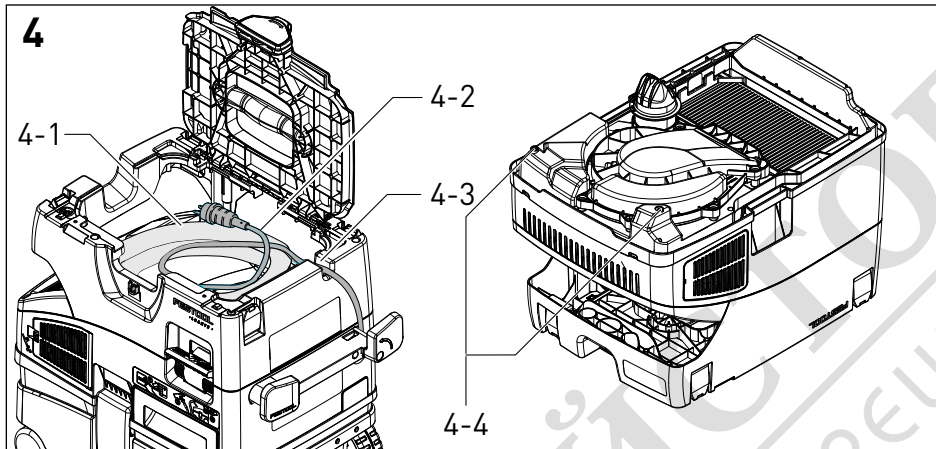

Contents

1	Safety instructions.....	13
2	Symbols.....	13
3	Parts of the machine.....	14
4	Technical data.....	14
5	Intended use.....	14
6	Commissioning.....	15
7	Settings.....	16
8	Working.....	17
9	Service and maintenance.....	18
10	Environment.....	18

1 Safety instructions



Warning! Read and observe all information and safety instructions. Failure to observe the information and safety instructions may lead to electric shocks, fires and/or serious injuries.

Keep all safety information and instructions for future reference.

- This appliance must not be used by persons (including children) with reduced physical, sensory or mental capabilities, or lack of experience and knowledge. **Children** need to be supervised to ensure they do not play with the device.
- If the mains power cable is damaged, it must be replaced by an authorised service workshop to prevent it posing a risk.
- **Warning** Operators must be appropriately instructed in the use of this machine.
- The mains plug must always be disconnected from the socket before performing cleaning or maintenance tasks, when replacing consumables or when converting the machine.
- **Warning** Only use the electrical outlet module on the machine for the purposes specified in the instructions.
- **Warning** If foam or fluid starts to escape, switch off the machine immediately.
- **Caution** Regularly clean the water level limiting device and inspect it for signs of damage.
- Sound pressure level as per EN 60335-2-69/uncertainty K
70 dB(A)/3 dB
- Hand-arm vibration value as per EN 60335-6-69/uncertainty K
< 2.5 m/s² / 1.5 m/s²



- **Warning** Device may contain hazardous dust. Only have the device maintained and emptied, and only have the filter replaced by an authorised specialist using suitable protective equipment.
- Always operate with the filter system installed!
- **Risk of explosion and fire: Do not extract:**
 - Sparks or hot dust;
 - combustible or explosive materials (e.g. magnesium, aluminium, petrol, diluting agents);
 - aggressive materials (e.g. acid, alkaline solutions, solvents);
 - chemically reactive materials, which lead to the generation of heat, acids/bases, gases, etc. (e.g. reactive two-component materials, aluminium and water).
- Observe all national safety regulations as well as the material manufacturer's specifications!
- Always use suitable protective equipment!
- If intact following a visual inspection, work in a dry environment according to instructions!
- Check the plug and the cable regularly in order to prevent a hazard. In the event of damage, these must be replaced by an authorised service workshop only.
- Do not lift or transport the device using a crane hook or lifting gear.

2 Symbols



Warning of general danger



Risk of electric shock



Read the operating instructions/notes.



Wear a dust mask.



Warning! The machine may contain hazardous dust!



Suitable for separation of dust with an exposure limit value greater than 1 mg/m³



Do not dispose of it with domestic waste.



Climbing prohibited

3 Parts of the machine

[1-2]	Appliance socket
[1-3]	SysDoc
[1-4]	Handle
[1-7]	Hose holder
[1-8]	T-Loc lock for Systainers
[1-9]	Dirt trap

[1-10]	Locking clip
[1-11]	On/off switch
[1-12] + [1-13]	Brake
[1-14]	Exhaust opening
[1-15]	Filter drawer
[1-16]	Dedusting
[1-17]	MAN button
[1-18]	Suction power adjustment
[1-19]	Connection display
[1-20]	Connection button

The specified figures appear at the beginning of the operating manual.

4 Technical data

Mobile dust extractors		
Power consumption		350–1200 W
Max. electrical outlet module connected load	EU, KR, CN	2200 W
	CH, DK	1150 W
	GB 230 V/110 V	1610 W/770 W
Max. suction capacity (air), extractor/turbine		130 m ³ /h / 222 m ³ /h
Max. vacuum, turbine		24,000 Pa
Filter surface area		3369 cm ²
Suction hose		D 27/32 mm x 3.5 m-AS
Mains power cable length		7.5 m
Sound pressure level as per EN 60335-2-69/uncertainty K		70 dB(A)/3 dB
Hand-arm vibration value as per EN 60335-2-69/uncertainty K		< 2.5 m/s ² / 1.5 m/s ²
Degree of protection		IP X4
Container capacity	CTL MINI I	10 l
	CTL MIDI I	15 l
Dimensions L x W x H	CTL MINI I	470 × 320 × 455 mm
	CTL MIDI I	470 × 320 × 495 mm
Weight	CTL MINI I	11.0 kg
	CTL MIDI I	11.3 kg

5 Intended use

Mobile dust extractor suitable for

- extracting dust up to 1 mg/m³ according to dust class L,
- extracting water,
- for increased loads during commercial use,

according to IEC/EN 60335-2-69.



The user is liable for improper or non-intended use.

6 Commissioning



WARNING

Unauthorised voltage or frequency!

Risk of accidents

- ▶ Observe the specifications on the machine's name plate.
- ▶ Observe country-specific regulations.

6.1 Initial commissioning

- ▶ Insert the filter/disposal bag [2].
- ▶ Fit the cord holder [3].
- ▶ Connect the suction hose [3].

6.2 Connecting the mobile dust extractor



WARNING

Risk of injury from uncontrolled tool start-up

- ▶ Before switching on ensure that the connected tool is switched off.



WARNING

Risk of injury from electric current

- ▶ Insert the mains plug into an earthed socket.
- ▶ Do not reach into the electrical outlet module on the mobile dust extractor.



While the mobile dust extractor is connected to the mains socket, an electric current is running through electrical outlet module on the mobile dust extractor at all times.

Connecting the mobile dust extractor to a mains socket

The mobile dust extractor is switched off.

- ▶ Connect the power cable to a mains socket. The electrical outlet module [1-2] is live.

Switching the mobile dust extractor to standby mode

- ▶ Press the on/off switch [1-11]. The electrical outlet module [1-2] is live.



The green LED [1-18] indicates standby mode.

Starting the mobile dust extractor automatically

The mobile dust extractor is in standby mode.

- ▶ To start the mobile dust extractor automatically: Switch on the connected tool.

Starting the mobile dust extractor manually

The mobile dust extractor is in standby mode.

- ▶ Press the MAN button [1-17].



Pull the mains plug from the socket when you are not using the mobile dust extractor and before performing any cleaning and maintenance work.

6.3 Connecting a power tool



WARNING

Risk of injury

- ▶ Observe the maximum electrical outlet module connected load (see chapter "Technical data").
- ▶ Switch off the power tool.

Connecting a mains-powered power tool to the mobile dust extractor

- ▶ Connect the power tool to the electric outlet module [1-2].

The power tool is connected to the mobile dust extractor via the power cable.

Connecting a battery-powered power tool to the mobile dust extractor (MINI I / MIDI I)

- ▶ In standby mode, press the connection button [1-20].

The connection display [1-19] flashes slowly. For a period of 60 seconds, the mobile dust extractor is ready for connection.

- ▶ Turn on the battery-powered power tool. The mobile dust extractor starts up and the battery-powered power tool is connected until the mobile dust extractor is manually switched off or the mains plug is disconnected. The battery-powered tool must then be connected again.

Connecting a new battery-powered power tool overwrites the previous connection.

6.4 Connecting a mobile device (MINI I / MIDI I)

A mobile device (e.g. smartphone) can be connected to the mobile dust extractor via **Bluetooth®** (e.g. for a software update with the Festool app).

- ▶ Hold down the connection button [1-20] on the mobile dust extractor for three seconds in standby mode.

The connection display [1-19] flashes rapidly.

For a period of 60 seconds, the mobile dust extractor is ready for connection.

- ▶ Follow the instructions provided in the Festool app.

6.5 Remote control (MINI I / MIDI I)

Connecting the remote control and mobile dust extractor

To be able to connect a remote control to a mobile dust extractor, the remote control must be reset (see "Resetting the remote control").

Remote controls that have not been connected previously can be connected directly.

 A connection that has been created between remote controls and the mobile dust extractor will persist even after the mobile dust extractor has been manually switched off or the mains plug has been disconnected.

 The mobile dust extractor can be connected to as many as five remote controls at the same time. The mobile dust extractor can only be connected to one cordless power tool at a time.

- ▶ Hold down the connection button [1-20] on the mobile dust extractor for three seconds in standby mode.
The connection display [1-19] flashes rapidly.
For a period of 60 seconds, the mobile dust extractor is ready for connection.
- ▶ Press the MAN button on the remote control.
The remote control is permanently stored in the mobile dust extractor.

Switching on/off

Once the remote control is connected to the mobile dust extractor, the mobile dust extractor can be switched on and off with the remote control.

- ▶ Press the MAN button on the remote control to switch the device on and off.

Resetting the remote control

Resetting deletes the connection between a remote control and the mobile dust extractor.

- ▶ Hold down the connection button and the MAN button for 10 seconds.
The LED indicator lights up purple, if the reset has taken place.

6.6 Delete all saved devices. (MINI I / MIDI I)

- ▶ Press and hold the connection button [1-20] for at least three seconds.

The connection display [1-19] flashes rapidly.

- ▶ Press and hold both the plus and minus button [1-18] for at least three seconds.
The mobile dust extractor confirms the command by rapidly flashing three times.

7 Settings

7.1 Adjusting the suction power

- ▶ Press the plus or minus button [1-18] while extracting.

7.2 Temperature cut-out

A temperature cut-out switches the mobile dust extractor off when it reaches a critical temperature to prevent overheating. The bottom LED [1-18] indicates a fault.

LED lights up red Excessive temperature

- ▶ Switch off the mobile dust extractor, let it cool down.
- ▶ Switch on the mobile dust extractor again after approx. five minutes.

7.3 Locking the brake [1A]

- ▶ Raise the front of the mobile dust extractor slightly.
- ▶ Push down the brake [1-13] until it engages into position.
- ▶ Actuate the button [1-12] to release it.

7.4 SysDoc



WARNING

Risk of injury

- ▶ Do not stand on the storage area of the mobile dust extractor.



CAUTION



Risk of injury



- ▶ Ensure that the T-Loc or the four SysDoc locks are closed during transport.

A Systainer can be fastened to the storage area [1-7] with the T-Loc lock [1-8]. Systainers without T-Loc can be secured with the four SysDoc locks [1-3].

8 Working

8.1 Extracting dry materials

		CAUTION
Hazardous dust		
Damage to the respiratory passage		
▶ Always use a filter bag!		

		CAUTION
Hazardous dust		
Damage to the respiratory passage		
▶ Check that the main filter is undamaged before extracting.		

 When extracting dust that exceeds the limit value, only extract from one dust source (power or compressed-air tool).

Observe the following when extracting dust generated by operating power tools: Ensure there is adequate ventilation! Observe regional regulations!

Limit values: Exhaust air max. 50% of the fresh air volume

Equation: Room volume V_R x air renewal rate L_W

8.2 Extracting wet materials/liquids



 Remove the filter bag!
Use a special wet filter.

The dust extractor stops automatically when the maximum fill level is reached.

The bottom LED [1-18] lights up red.

- ▶ Switch off the mobile dust extractor [1-11].
- ▶ Open the locking clips [1-10] and remove the top section of the machine.
- ▶ Empty the dirt trap [1-9].

After wet extraction, allow the main filter to dry!
Dry the mobile dust extractor before extracting dry dust.

		CAUTION
Hazardous dust		
Damage to the respiratory passage		
▶ After extracting wet materials, remove the wet filter and replace it with the main filter for dry materials.		

	CAUTION
Escaping foam and fluids	
▶ Switch off and empty the machine immediately.	

8.3 Blow-out function

- ▶ Open the grille in front of the exhaust opening [1-14].
- ▶ Insert the suction hose in the exhaust opening [1-14].
- ▶ In standby mode, press the MAN button [1-17].

8.4 Cleaning the filter and filter bag manually

- ▶ In standby mode, press the MAN button [1-17].
- ▶ Set the suction power to the maximum setting [1-18].
- ▶ Cover the suction hose with your hand while at the same time briefly pressing down the cleaning lever [1-16] three times.

8.5 Changing the filter bag with minimal dust

- ▶ Open the locking clips and remove the top section of the machine [2].
- ▶ Pull the tab on the filter bag until the filter bag opening is fully closed.

The filter bag is now securely closed and can be removed.

- ▶ Fit the top section of the machine and close the locking clips.

8.6 Changing the filter element[5]

- ▶ Pull out the used filter drawer [1-15].
- ▶ Dispose of the used filter drawer in accordance with statutory regulations.
- ▶ Insert the new filter drawer [1-15].

 Order numbers for accessories, filters and consumables in the Festool catalogue or online at "www.festool.com".

NOTICE

Damage to the motor

- ▶ Never extract material without a main filter or with a damaged main filter, as this can damage the motor.

8.7 After finishing work

- ▶ Switch off the mobile dust extractor and pull out the mains plug.
- ▶ Wind up the mains power cable.
- ▶ Empty the dirt trap.
- ▶ Place the suction hose [4-1] in the sealable hose holder [1-7]. Place the mains power cable [4-2] in the sealable hose hold-

er [1-7] or wind it up on the cord holder. To do so, lay the power cable through the recess [4-3].

- ▶ Vacuum and wipe the inside and outside of the mobile dust extractor to clean it.
- ▶ Place the mobile dust extractor in a dry room inaccessible to unauthorised users.



The lid of the hose holder also serves as a storage area for tools.

9 Service and maintenance



WARNING

Risk of injury, electric shock

- ▶ Always pull the mains plug from the socket before performing any servicing and maintenance work.
- ▶ All maintenance and repair work which requires the motor housing to be opened should always be carried out by an authorised service workshop.



Customer service and repairs must only be carried out by the manufacturer or service workshops: Find the nearest address at: www.festool.com/service



Always use original Festool spare parts. Order no. at: www.festool.com/service

- ▶ Regularly clean the fill level sensors [4-4] and empty the dirt trap.

Observe the following information:

- Dust-related inspection (e.g. for filter damage, tightness of the machine and function of the control devices) by the manufacturer or an instructed person at least once a year.
- Dispose of components that cannot be cleaned. Use impermeable bags to do so. Observe the applicable disposal provisions!

10 Environment



Do not dispose of the device in the household waste! Recycle devices, accessories and packaging. Observe applicable national regulations.

EU only: In accordance with European Directive on waste electrical and electronic equipment and implementation in national law, used power tools must be collected separately and handed in for environmentally friendly recycling.

Information on REACH: www.festool.com/reach

The Bluetooth® word mark and the logos are registered trademarks of Bluetooth SIG, Inc.; they are used by TTS Tooltechnic Systems AG & Co. KG, and therefore by Festool, under licence.