

D	Originalbetriebsanleitung - Absaugmobil	7
GB	Original operating manual - Mobile dust extractors	12
F	Notice d'utilisation d'origine - Aspirateurs mobile	17
E	Manual de instrucciones original - Sistemas móviles de aspiración	22
I	Istruzioni per l'uso originali - Unità mobili d'aspirazione	27
NL	Originele gebruiksaanwijzing - Mobiele afzuigapparaten	32
S	Originalbruksanvisning - Dammsugare	37
FIN	Alkuperäiset käyttöohjeet - Siirrettävät imurit	42
DK	Original brugsanvisning - Støvsugere	47
N	Originalbruksanvisning - Mobil støv-/våtsuger	52
P	Manual de instruções original - Aspiradores móveis	57
RUS	Оригинал Руководства по эксплуатации - Пылеудаляющие аппараты	62
CZ	Originál návodu k obsluze - Mobilní vysavače	68
PL	Oryginalna instrukcja eksploatacji - Odkurzacze mobilne	73

**CTL 26 E, CTL 26 E SD,
CTL 26 E AC, CTL 26 E SD E/A,
CTL 36 E, CTL 36 E AC,
CTL 36 E AC-LHS,
CTL 36 E LE,
CTL 48 E, CTL 48 E AC**

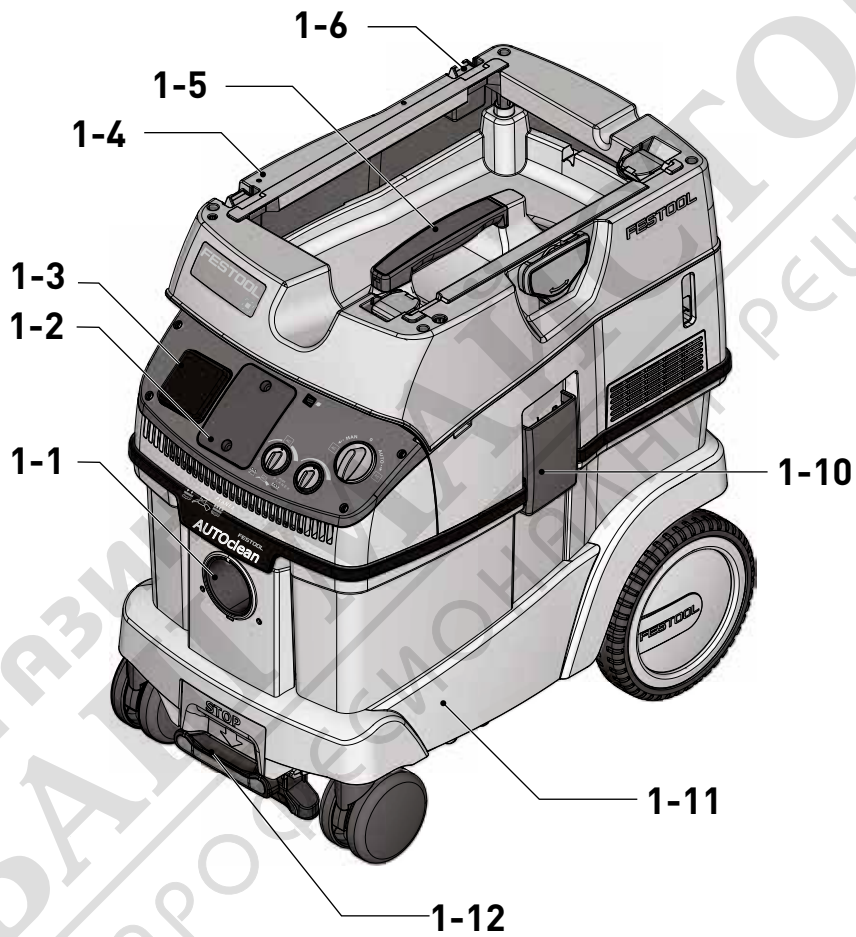

1

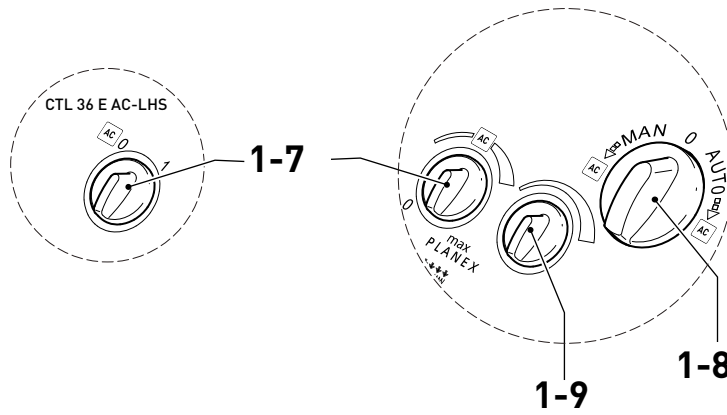

2

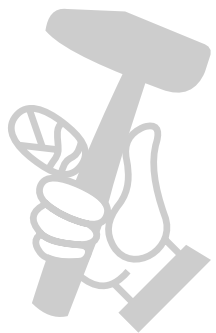
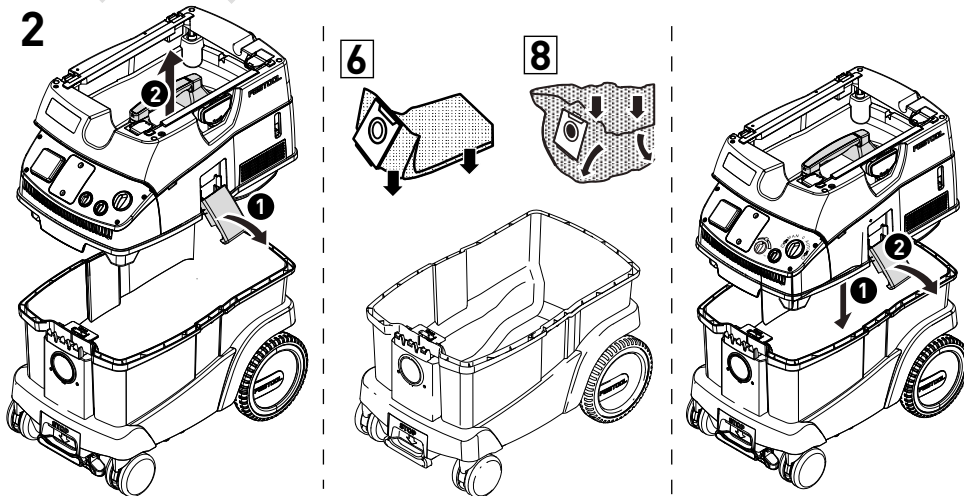

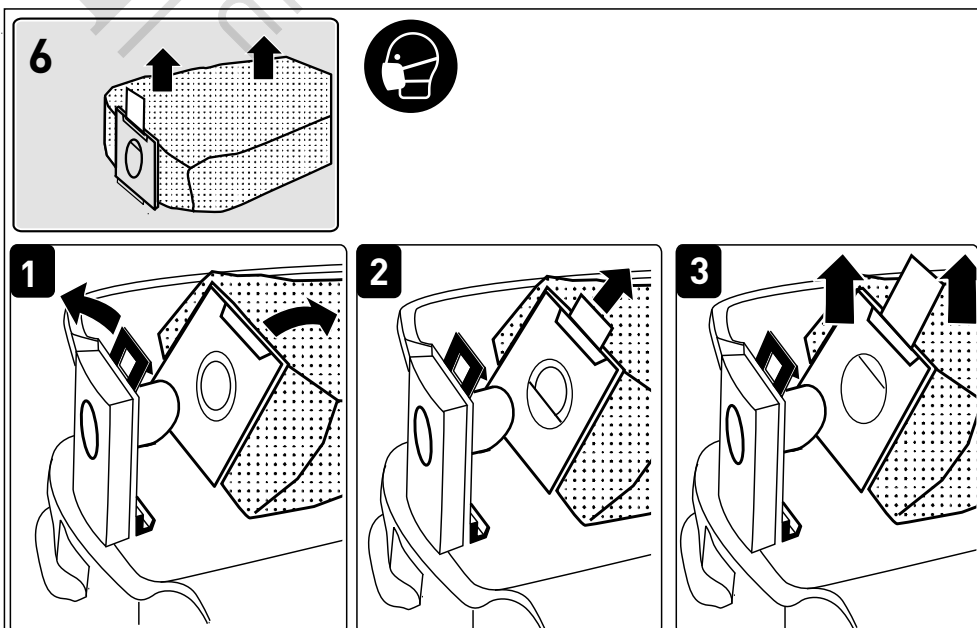
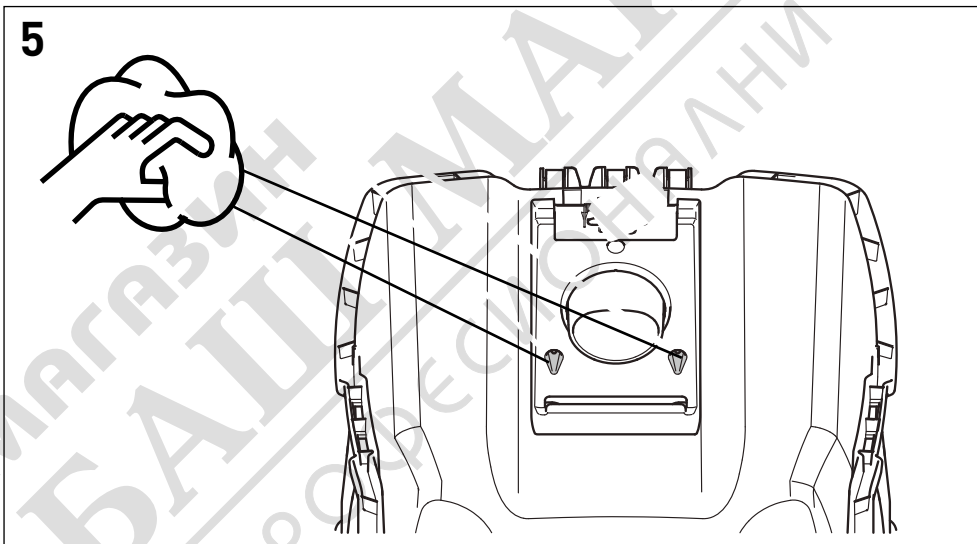
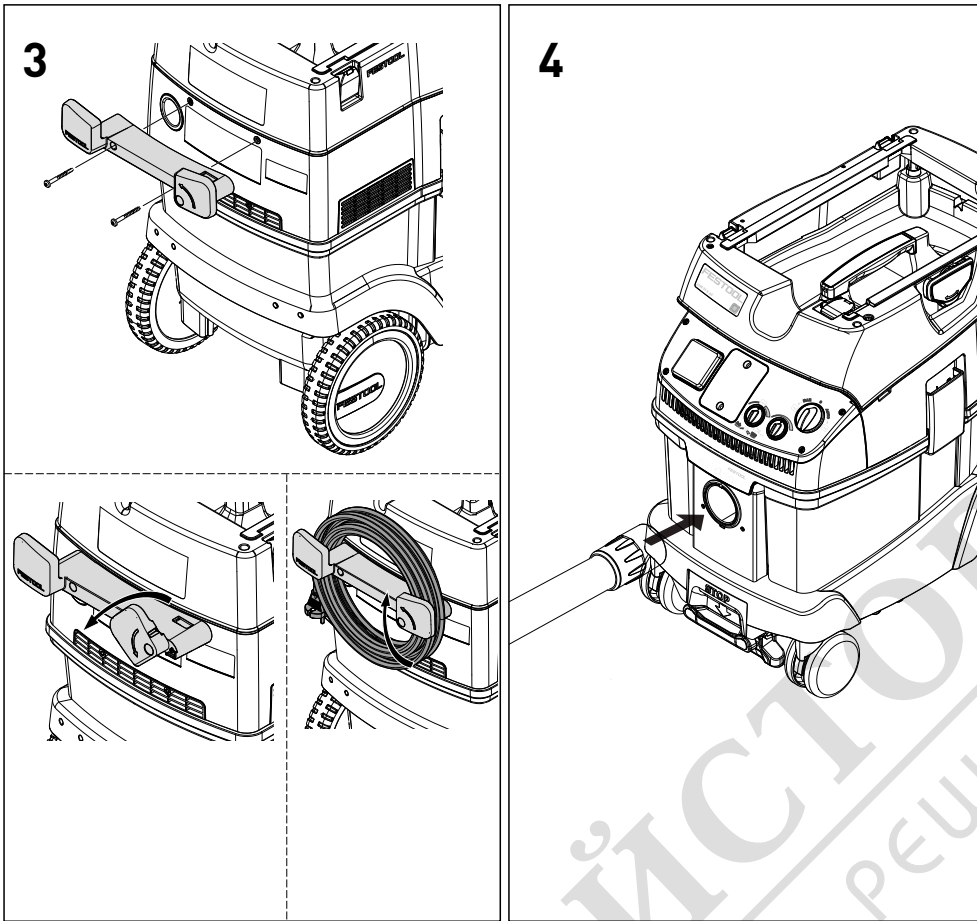

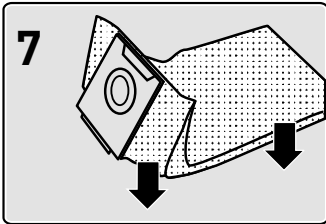

—> SC FIS-CT26
SC FIS-CT36
SC FIS-CT48

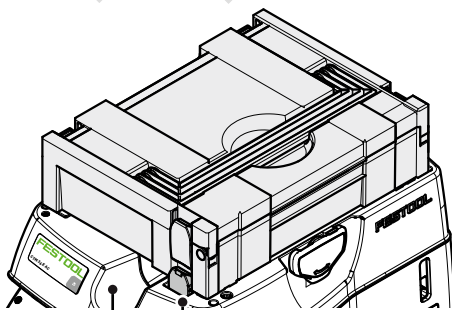
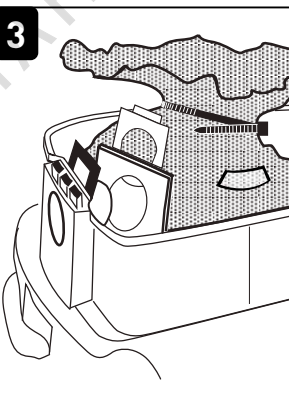
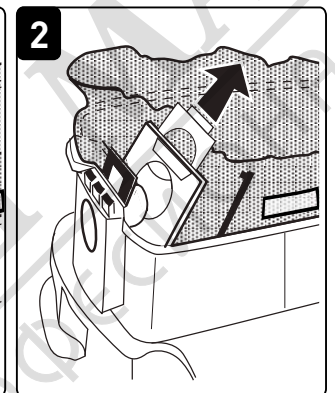
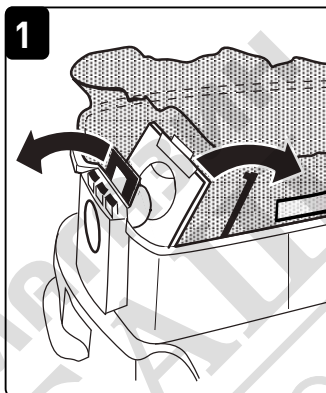
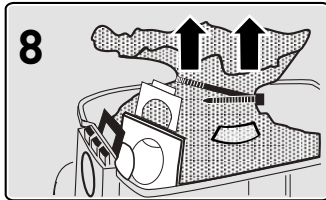
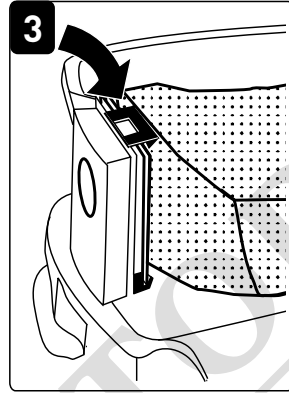
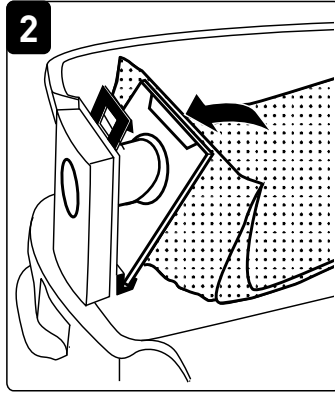
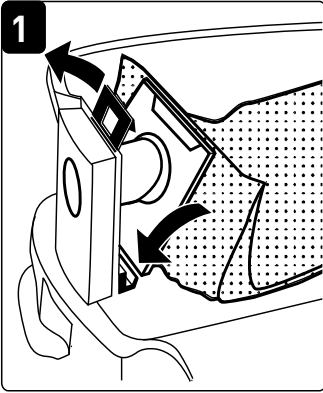

8-2

8-1

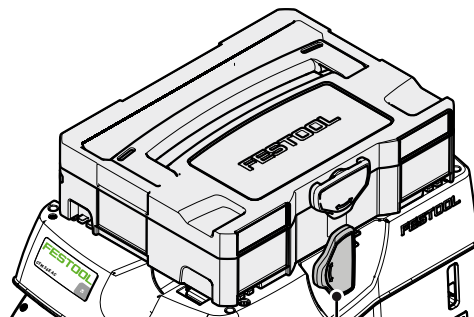

8-1

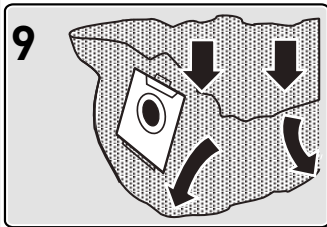

ENS-CT26
ENS-CT36
ENS-CT48

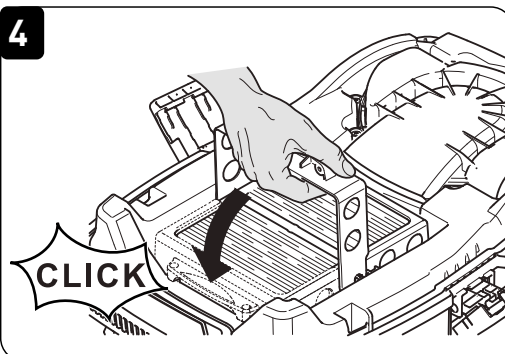
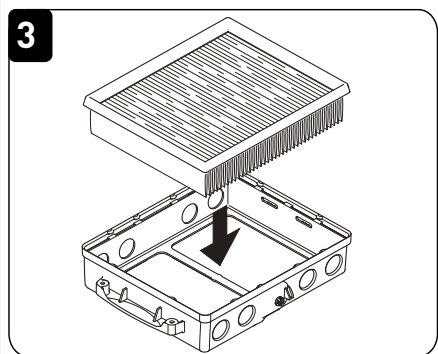
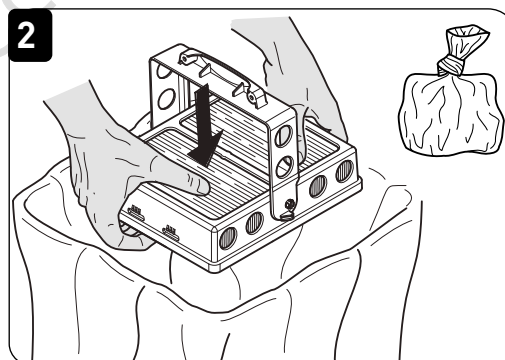
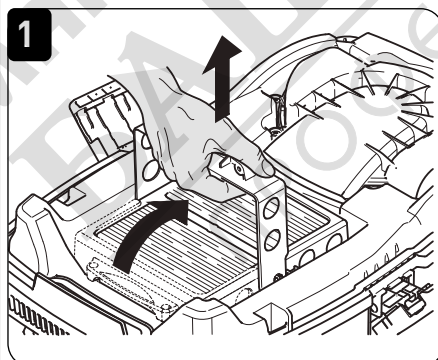
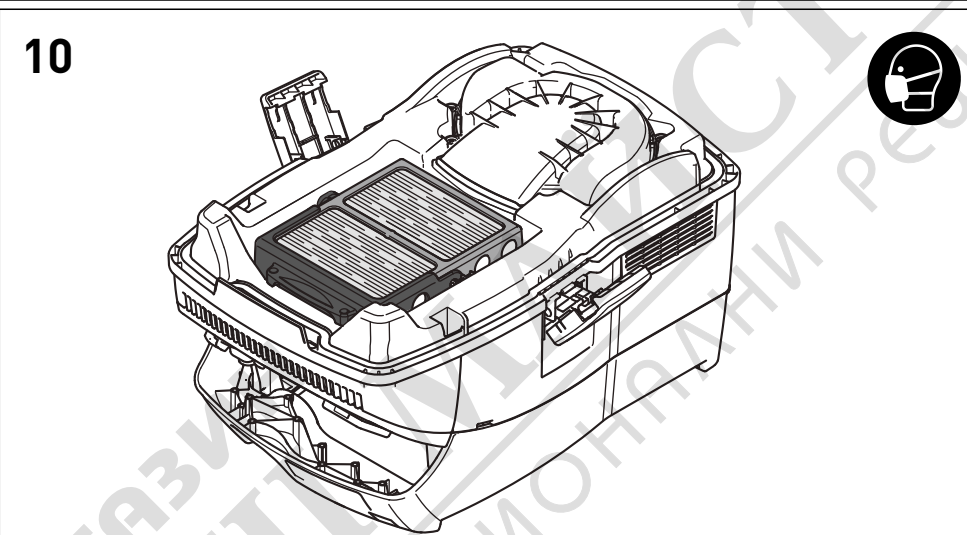
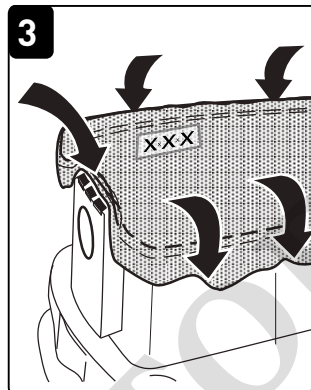
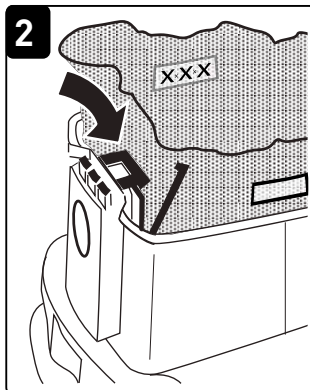
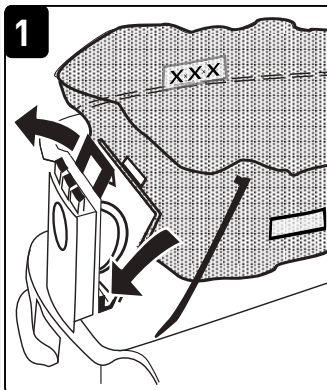
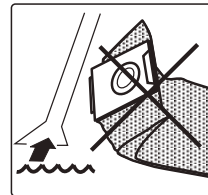

Contents

1	Safety instructions.....	12
2	Technical data.....	12
3	Symbols.....	13
4	Machine features.....	13
5	Intended use.....	13
6	Operation.....	13
7	Settings.....	14
8	Working.....	15
9	Service and maintenance.....	15
10	Environment.....	16

1 Safety instructions



WARNING! Read all safety warnings, instructions, illustrations and specifications provided with this tool. Failure to follow all instructions listed below may result in electric shock, fire and/or serious injury.

Save all warnings and instructions for future reference.

- This appliance must not be used by persons (including children) with reduced physical, sensory or mental capabilities, or lack of experience and knowledge. **Children** need to be supervised to ensure they do not play with the appliance.

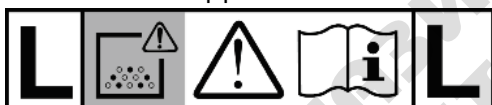

- **WARNING!** Machine may contain hazardous dust. Only authorised qualified specialists

2 Technical data

Mobile dust extractors

Power consumption		350 -1200 W
Maximum appliance socket connected load	EU	2400 W
	CH, DK	1100 W
	GB 240 V/ 110 V	1800 W/ 500 W
Max. suction capacity (air), turbine		234 m ³ /h (3900 l/min)
Max. vacuum, turbine		24000 Pa
Filter surface area		6318 cm ²
Suction hose		D 27 mm x 3.5 m-AS
Length of the net cable		7.5 m
Sound pressure level as per EN 60704-2-1 / Uncertainty K		71 dB(A) / 3 dB
Protection category		IP X4

with suitable protective equipment may perform maintenance, empty the container and change the filter.

- Always operate with the filter system installed!
- **Risk of explosion and fire: Do not absorb:**
 - Sparks or hot dust;
 - Combustible or explosive materials (e.g. magnesium, aluminium, petrol, diluting agents);
 - Aggressive materials (e.g. acid, alkaline solutions, solvents);
 - Chemically reactive materials, which lead to the generation of heat, acids/bases, gases, etc. (e.g. reactive 2-component materials, aluminium and water).
- Observe all national safety regulations as well as the material manufacturer's specifications!
- Always use suitable protective equipment!
- If intact following a visual inspection, work in a dry environment according to instructions!
- Always use the socket on the machine for the purpose specified!
- Check the plug and the cable regularly and should either become damaged, in order to avoid a hazard, have them replaced by an authorised after-sales service workshop.
- Do not lift or transport using a crane hook or lifting gear!

Mobile dust extractors

Container capacity	CTL 26 E, CTL 26 E AC, CTL 26 E SD	26 l
	CTL 36 E, CTL 36 E LE, CTL 36 E AC, CTL 36 E LE AC, CTL 36 E AC-LHS	36 l
	CTL 48 E, CTL 48 E LE, CTL 48 E AC, CTL 48 E LE AC	48 l
Dimensions L x W x H	CTL 26 E, CTL 26 E AC, CTL 26 E SD	630 x 365 x 540 mm
	CTL 36 E, CTL 36 E LE, CTL 36 E AC, CTL 36 E LE AC, CTL 36 E AC-LHS	630 x 365 x 596 mm
	CTL 48 E, CTL 48 E LE, CTL 48 E AC, CTL 48 E LE AC	740 x 406 x 1005 mm
Weight	CTL 26 E, CTL 26 E SD	13.9 kg
	CTL 36 E, CTL 36 E LE	14.4 kg
	CTL 48 E, CTL 48 E LE	18.8 kg
	CTL 26 E AC	14.7 kg
	CTL 36 E AC, CTL 36 E LE AC, CTL 36 E AC-LHS	15.2 kg
	CTL 48 E AC, CTL 48 E LE AC	19.6 kg

3 Symbols

Symbol Significance



Warning of general danger



Risk of electric shock



Read operating instructions and safety notices!



Wear a dust mask.



Tip or advice



Handling instruction



Warning! The machine may contain hazardous dust!



Do not dispose of as domestic waste.

[1-7] Automatic cleaning (only versions with AutoClean)

[1-8] Switch

[1-9] Suction power adjuster

[1-10] Locking clip

[1-11] Dust container

[1-13] Brake

The specified illustrations appear at the beginning of the Operating Instructions.

5 Intended use

Mobile dust extractor suitable for

- Extracting dust up to 1 mg/m³ according to dust class 'L',
- Extracting water,
- Increased loads during commercial use, according to IEC/EN 60335-2-69.



The user is liable for improper or non-intended use.

6 Operation



WARNING

Unauthorised voltage or frequency!

Risk of accidents

- Observe the specifications on the machine's name plate.
- Observe country-specific regulations.

6.1 Initial operation

4 Machine features

[1-1] Intake opening

[1-2] Module slot

(compressed air module for CTL 36/48 E LE, CTL 36/48 E LE AC, socket module for CTL 26 E SD)

[1-3] Appliance socket

[1-4] Hose store

[1-5] Handle

[1-6] SysDoc

- ▶ Insert the filter/disposal bag [2].
- ▶ Attach the cord holder [3].
- ▶ Connect the suction hose [4].

6.2 Connecting the mobile dust extractor



WARNING

Risk of injury from tools starting up unexpectedly

- ▶ Before setting the switch to the "AUTO" or "MAN" position, make sure that the connected tool is switched off.

The switch [1-8] serves as an on/off switch.

Switch position "0"

Appliance socket [1-3] is disconnected from the power, mobile dust extractor is switched off.

"MAN" switch position

Appliance socket [1-3] is connected to the power, the mobile dust extractor starts.

"Auto" switch position

Appliance socket [1-3] is connected to the power, the mobile dust extractor starts when the connected tool is switched on.

- ▶ Insert the plug into an earthed socket.



Pull the plug from the socket when the machine is not in use and prior to maintenance and cleaning work.

6.3 Connecting electric power tools



WARNING

Risk of injury

- ▶ Observe the maximum appliance socket connected load (see chapter "Technical data")
- ▶ Switch off the electric power tool.

- ▶ Connect the electric power tool to the appliance socket [1-3].

Special features of CTL26 E SD

- **CTL 26 E SD E/A:** Socket module with automatic switch-on function for the use of two electric power tools: e.g. 2 sanders, 1 jig-saw + 1 sander
- **CTL 26 E SD:** Socket module with permanent power supply for use as extension cable: e.g. charger, lamp, etc.

6.4 Connecting pneumatic tools



WARNING

Risk of injury

- ▶ Switch off the air tool.

Automatic on/off switch for air tools (CTL 36/48 E LE, CTL 36/48 E LE AC or accessories) with compressed air module in module slot [1-2]

Recommendation:

- Attachment of service unit VE (495886): compressed air filtered and lubricated
- Use of IAS system with IAS connector (454757) for Festool air tools

Requirement: tool with operating pressure of 6 bar!

6.5 Special features of the CTL 36 E AC-LHS

To use the mobile dust extractor in combination with the **PLANEX**:

- ▶ Use kink-resistant suction hose D 36 mm x 3.5 m-AS.
- ▶ Use a special suction sleeve for connecting the **PLANEX**.
- ▶ Use closing slide CT-VS between the intake opening [1-1] and suction hose.
- ▶ Attach the tool holder.
- ▶ **Always use with a disposal bag!**

7 Settings

7.1 Adjusting the suction power

- ▶ Use the rotary knob [1-9].

7.2 Temperature cut-out

A temperature cut-out switches the mobile dust extractor off when it reaches a critical temperature to prevent overheating.

- ▶ Switch off the mobile dust extractor, allow to cool for about 5 minutes then switch on again.



Not possible to switch on: contact Festool service workshop.

7.3 AUTOClean - Cleaning the main filter (only versions with AutoClean)



Only in conjunction with disposal bag (compliance with dust class 'L'). Not suitable for wet extraction!

Automatic cleaning

Adjust the frequency using the rotary knob [1-7].

Only CTL for 36 E AC-LHS: switch on using the rotary knob [1-7].

Manual cleaning

Turn the switch [1-8] to the **AC** symbol.

Full manual cleaning

- ▶ Cover the end of the nozzle or suction hose with your hand or closing slide CT-VS (497926) for 2 seconds.
- ▶ Turn the switch [1-8] to the **AC** symbol.



8 Working

8.1 Handling

Hose store: after finishing work, you can feed the suction hose through the recess [8-2] and place it in the hose store.

SysDoc Systainer attachment system: a Systainer can be attached to the storage area via the four slides or the T-Loc [8-1].

8.2 Extracting dry materials

 	CAUTION
Hazardous dust	
Damage to the respiratory passage	
▶ Always use a filter or disposal bag!	

 When extracting dust that exceeds the permitted limit values, only extract from a single machine (electric or air tool).

Observe the following when extracting dust generated by operating electric power tools: Ensure there is adequate ventilation! Observe regional regulations!

Limit values: exhaust air max. 50% of the clear air volume

Formula: room volume V_R x air renewal rate L_W

8.3 Extracting wet materials/liquids

 Remove the filter or disposal bag!
Recommendation: use special wet filter (NF-CT).

The dust extractor stops automatically when the maximum level is reached.

After wet extraction, allow the main filter to dry!



CAUTION

Escaping foam and fluids

- ▶ Switch off and empty the machine immediately.

8.4 After finishing work

- ▶ **Only versions with AutoClean:** Clean the main filter automatically or manually (see chapter 7.3).
- ▶ Switch off the mobile dust extractor and pull out the mains plug.
- ▶ Wind up the mains power cable.
- ▶ Empty the dirt trap.
- ▶ Place the mobile dust extractor in a dry room inaccessible to unauthorised users.

9 Service and maintenance



WARNING

Risk of injury, electric shock

- ▶ Always disconnect the mains plug from the socket before performing maintenance work on the machine!
- ▶ All maintenance and repair work which requires the motor housing to be opened must only be carried out by an authorised service workshop.



Customer service and repair only through manufacturer or service workshops: Please find the nearest address at: www.festool.com/service



Only use original Festool spare parts! Order No. at: www.festool.com/service

- ▶ Clean the level sensors [5] and empty the dirt trap [1-11] regularly.

Observe the following instructions:

- The manufacturer or an instructed person must perform a dust test at least once a year to determine whether the filter is damaged, the machine is sealed properly

and the monitoring features are functioning correctly.

- Anything that cannot be cleaned must be discarded in impermeable bags. Observe applicable disposal regulations!

9.1 Filter bag / disposal bag / main filter

- ▶ Remove the filter bag [6].
 - ▶ Insert the filter bag [7].
 - ▶ Remove the disposal bag [8].
 - ▶ Insert the disposal bag [9].
 - ▶ Change the main filter [10].
- Dispose of the used filter in accordance with statutory regulations.

 The order numbers for accessories, filters and consumables can be found in the Festool catalogue or on the internet at www.festool.com.

10 Environment

 **Do not dispose of the device in household waste!** Recycle devices, accessories and packaging. Observe applicable national regulations.

EU only: In accordance with European Directive on waste electrical and electronic equipment and implementation in national law, used electric power tools must be collected separately and handed in for environmentally friendly recycling.

Information on REACH: www.festool.com/reach

