

ELECTRIC TOOL PARTS LIST

DEMOLITION HAMMER Model H 60ME

2016-6-13
(E1)

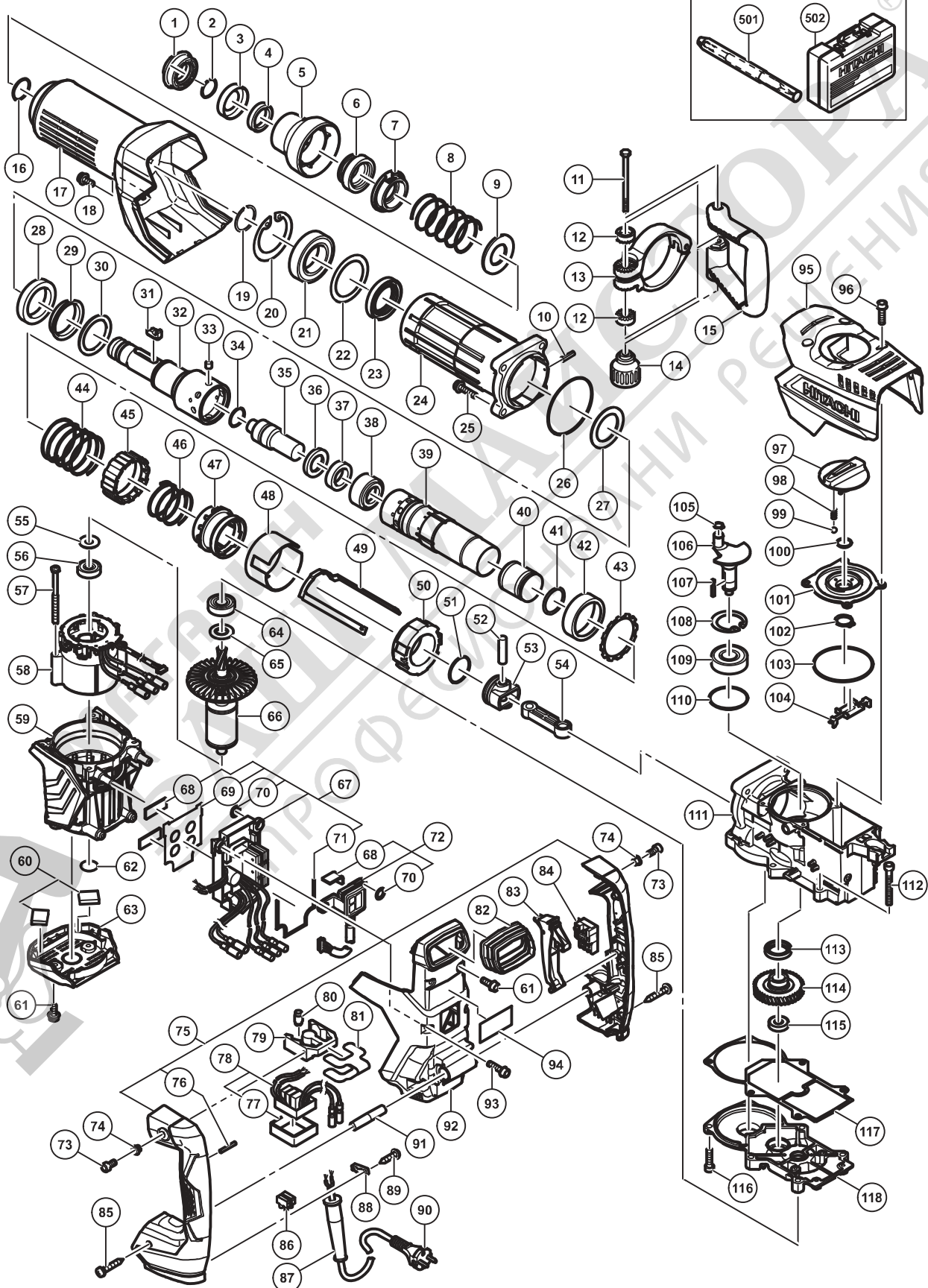

PARTS

H 60ME

ITEM NO.	CODE NO.	DESCRIPTION	NO. USED	REMARKS
1	337562	FRONT CAP	1	
2	318590	STOPPER RING	1	
3	338155	RETAINER WASHER	1	
4	339053	RETAINER DAMPER (A)	1	
5	338154	GRIP	1	
6	370669	BIT LOCK HOLDER	1	
7	370668	THRUST PLATE	1	
8	339052	RETAINER SPRING	1	
9	337557	SPRING HOLDER (A)	1	
10	949860	ROLL PIN D2 X 10 (10 PCS.)	1	
11	333228	BOLT M8	1	
12	333202	HANDLE HOLDER (B)	2	
13	370393	HANDLE HOLDER	1	
14	333201	GRIP	1	
15	333199	SIDE HANDLE	1	
16	872470	O-RING (S-26)	1	
17	338198	CYLINDER CASE COVER	1	
18	998471	HEX. SOCKET HD. BOLT (W/FLANGE) M5 X 12	1	
19	318582	RETAINING RING D40	1	
20	338200	RETAINING RING D68	1	
21	339063	BALL BEARING 6008DDU	1	
22	338201	BEARING WASHER	1	
23	318588	OIL SEAL (NBR710)	1	
24	338199	CYLINDER CASE	1	
25	990083	HEX. SOCKET HD. BOLT (W/FLANGE) M8 X 35	4	
26	338222	O-RING (C)	1	
27	338204	RETAINER DAMPER HOLDER	1	
28	338203	RETAINER DAMPER (B)	1	
29	339064	DAMPER SLEEVE	1	
30	338202	RETAINER DAMPER WASHER	1	
31	370654	BIT LOCK	2	
32	338205	RETAINER SLEEVE	1	
33	338210	NEEDLE PIN D8	8	
34	986104	O-RING	1	
35	370657	SECOND HAMMER	1	
36	370659	DAMPER WASHER	1	
37	328887	DAMPER	1	
38	370658	DAMPER HOLDER	1	
39	338209	CYLINDER	1	
40	370391	STRIKER	1	
41	328880	O-RING	1	
42	338211	SPRING HOLDER (B)	1	
43	338216	LOCK SPRING WASHER	1	
44	338217	LOCK SPRING	1	
45	338215	LOCK SLEEVE	1	
46	338212	CLUTCH SPRING	1	
47	370392	CLUTCH	1	
48	338218	SLEEVE	1	
49	338235	SLIDER	1	
50	370384	METAL (A)	1	

PARTS

H 60ME

ITEM NO.	CODE NO.	DESCRIPTION	NO. USED	REMARKS
51	328880	O-RING	1	
52	338228	PISTON PIN	1	
53	328877	PISTON	1	
54	328878	CONNECTING ROD	1	
55	944954	BEARING WASHER	1	
56	6201VV	BALL BEARING 6201VV	1	
57	961501	HEX. HD. TAPPING SCREW D5 X 60	2	
* 58	340947	STATOR SENSOR PCB SET 100V-120V	1	
* 58	340899	STATOR SENSOR PCB SET 220V-240V	1	
59	338168	HOUSING	1	
60	339065	PACKING (B)	2	
61	998485	HEX. SOCKET HD. BOLT (W/FLANGE) M5 X 14	4	
62	333225	DUST SEAL	1	
63	338170	TAIL COVER	1	
64	6202DD	BALL BEARING 6202DD	1	
65	980700	DUST WASHER (B)	1	
66	360992	ROTOR	1	
* 67	370386	CONTROLLER ASS'Y 100V-120V	1	INCLUD.68-71
* 67	370387	CONTROLLER ASS'Y 220V-240V	1	INCLUD.68-71
68	370655	CASE PACKING	3	
69	339056	RUBBER SHEET (C)	1	
70	339055	RUBBER SHEET (A)	4	
71	339057	RUBBER SHEET (D)	1	
72	370656	PANEL ASS'Y	1	INCLUD.68,70
73	991690	SEAL LOCK HEX. SOCKET HD. BOLT M5 X 12	2	
74	991711	DISTANCE PIECE (B)	2	
75	370394	HANDLE (A),(B) ASS'Y	1	INCLUD.76
76	949890	PIN D3 X 20 (10 PCS.)	1	
77	339058	FILTER PACKING	1	
* 78	338180	FILTER PCB ASS'Y 100V-127V	1	INCLUD.77
* 78	338181	FILTER PCB ASS'Y 220V-240V	1	INCLUD.77
79	310123	TRANSATORY UNIT	1	
80	310124	HANDLE DAMPER	4	
81	338162	HANDLE DAMPER HOLDER	1	
82	338176	BELLOWS	1	
83	370254	TRIGGER	1	
84	337587	SWITCH	1	
85	307028	TAPPING SCREW (W/FLANGE) D4 X 25 (BLACK)	5	
86	958308Z	PILLAR TERMINAL (A)	1	
* 87	940778	CORD ARMOR D10.7	1	
* 87	331335	CORD ARMOR D11.2	1	
88	960266	CORD CLIP	1	
89	984750	TAPPING SCREW (W/FLANGE) D4 X 16	2	
* 90	321537	CORD	1	(CORD ARMOR D10.7)
* 90	500469Z	CORD	1	(CORD ARMOR D10.7) FOR UAE,MAL
* 90	500483Z	CORD	1	(CORD ARMOR D11.2) FOR GBR (110V)
* 90	337366	CORD	1	(CORD ARMOR D10.7) FOR GBR (230V)
* 90	500453Z	CORD	1	(CORD ARMOR D10.7) FOR PAN (120V)
* 90	500457Z	CORD	1	(CORD ARMOR D10.7) FOR CHN
91	338175	HANDLE SHAFT	1	

