



Baukreissäge

Originalbetriebsanleitung – Sicherheitshinweise – Ersatzteile

D

Seite 1

Construction circular saw

Original instructions – Safety instructions – Spare parts

GB

Page 11

Scie circulaire de chantier

Notice originale – Consignes de sécurité – Pièces de rechange

F

Page 21

Cirkulární pila

Originální návod k použití – Bezpečnostní pokyny – Náhradní díly

CZ

Str 31

Sega circolare per cantieri

Istruzioni originali – Indicazioni per la sicurezza - Pezzi di ricambio

I

Pagina 41

Bouwcirkelzaag

Oorspronkelijke gebruiksaanwijzing - Veiligheidsinstructies
Reserveonderdelen

NL

Blz. 51

pila tarczowa budowlana

Instrukcja oryginalna – Wskazówki bezpieczeństwa
Części zamienne

PL

Stronie 61

Ferăstrău circular pentru construcții

Instrucțiuni originale – Măsuri de siguranță
Piese de schimb

RO

Pagina 71

Cirkulárna píla

Originálny návod na použitie - Bezpečnostné pokyny
Náhradné dielce

SK

Strana 81

CE





Do not operate machine before having read the operating instructions, understood all the notes and assembly the machine as described here.
Keep the instructions in a safe place for future use.

Contents

Declaration of conformity	11
Extent of delivery	11
Characteristics noise values	11
Operating times	11
Symbols machine	11
Symbols operating instructions	12
Normal intended use	12
Risidual risks	12
Safety working	12
Before the first start-up	13
Start-up	14
Working with the saw	15
Maintenance and cleaning	16
- Changing the saw blade	16
- Replacing the table insert	17
Transport	17
Storage	17
Guarantee	17
Possible faults	18
Technical data	18
Description of device / spare parts	19

EC Declaration of Conformity

according to EC directive 2006/42/EC

We,

ATIKA GmbH & Co. KG
Schinkelstraße 97
59227 Ahlen - Germany

herewith declare under our sole responsibility that the product **Baukreissäge (construction circular saw) type BTU 450**
Serial number: see last page

is conform with the above mentioned EC directives as well as with the provisions of the guidelines below:
2004/108/EC, 2000/14/EC and 2006/95/EC

Following harmonized standards have been applied:
EN 60204-1:2006; EN 1870-1:2007+A1:2009; EN 55014-1:2006;
EN 55014-2:1997+A1; EN 61000-3-2:2006; EN 61000-3-11:2000

Conformity assessment procedure: 2000/14/EC - Appendix V
Measured level of the acoustic output $L_{WA} = 106,3$ dB(A)
Guaranteed level of the acoustic output $L_{WA} = 110$ dB(A)

EC type examination carried out by :
Fachausschuss Holz – Vollmoellerstraße 11 – 70563 Stuttgart – Nr.: 0392
Certificate no.: HO 101119

Keeping of technical documents at:

ATIKA GmbH & Co. KG – Technical department – Schinkelstr. 97
59227 Ahlen – Germany

Ahlen, 21.05.2010

A. Pollmeier, management

Extent of delivery

- 1 Construction circular saw
- 1 Parallel limit stop
- 1 Pushstick
- Assembly accessories for saw blade change
- Operating manual



Check the machine for:

- That it is complete
- Check for possible transport damage

Report any damage or missing items to your dealer, supplier or the manufacturer immediately. Complaints made at a later date will not be acknowledged.

Characteristics noise values

EN ISO 3744:1995 / EN ISO 11202:1995/AC:1997 /
ISO 7960:1995 Appendix A, A.2 b)

Application of the machine as construction circular saw with standard saw blade.

Guaranteed sound power level $L_{WA} = 110$ dB(A)

Sound pressure level at the workplace No-load $L_{PA} = 86,6$ dB(A)
Load $L_{PA} = 94,5$ dB(A)

The factor of measurement uncertainty is $K = 4$ dB.

The values given are emission values and must therefore not simultaneously represent safe workplace values too. Although there is a relationship between emission and immersion levels, it can be reliably deduced whether additional precautionary measures are necessary or not. Factors, which can influence the immersion level currently existing at the workplace include the duration of the effects, the special type of the workroom, other noise sources, etc. e.g. the number of machines and other adjacent processes. The permissible workplace values can also vary from country to country. This information should however enable an improved assessment of the danger and risk to be carried out.





Operating times

Before initiating the device please observe the provisions pertaining to corresponding laws (regional provisions) for the noise control.

Symbols machine

	Carefully read operator's manual and the safety instructions before starting the machine and observe the instructions when operating.		Shut off engine and remove power cord before performing cleaning, maintenance or repair work.
	Wear ear protection!		
	Electrical devices do not go into the domestic rubbish. Give devices, accessories and packaging to an eco-friendly recycling. According to the European Directive 2002/96/EC on electrical and electronic scrap, electrical devices that are no longer serviceable must be separately collected and brought to a facility for an environmentally compatible recycling.		

Symbols operating instructions

	Threatened hazard or hazardous situation. Not observing this instruction can lead to injuries or cause damage to property.
	Important information on proper handling. Not observing this instruction can lead to faults.
	User information. This information helps you to use all the functions optimally.
	Assembly, operation and servicing. Here you are explained exactly what to do.

Normal intended use

- This construction circular saw is exclusively designed for lengthwise and cross cutting of solid wood and plate material such as chipboard, wood core plywood and MDF plates with square or rectangular cross section and a thickness of max. 150mm in the open outside of enclosed areas using carbide tipped circular saw blades acc. to EN 847-1. The saw blade diameter must be between 445 and 450 mm.
- Cross cuts may only be performed in conjunction with a mounted cross-cutting fence.
- Only materials that can be safely placed are allowed to be cut.
- The use of saw blades made of HSS steel (high-alloy high speed steel) is not permitted since this steel is hard and brittle. Risk of injury through saw blade breakage and expulsion of saw blade pieces.
- Normal intended use also includes the observance of the manufacturer's operating, maintenance and repair conditions, as well as strict adherence to the safety inspections listed in the instructions.
- The relevant accident prevention regulations for the operation as well as the other generally acknowledged occupational medicine and safety rules must be complied with.
- Any other use does not conform with the normal intended use of the circular saw bench. The manufacturer is not liable for any resulting damage; the user bears all risks!
- Unauthorized modifications to the saw preclude any liability of the manufacturer for resulting damages of any kind.
- The saw may only be equipped, used and serviced by persons who are familiar with it and have been instructed on the hazards. Repair works may only be carried out by us or by a customer service agent nominated by us.
- This machine must not be used in potential explosive atmospheres.
- Metallic parts (wires etc.) have unconditionally to be removed from the material to be cut.

Residual risks

Even if used properly, residual risks can exist even if the relevant safety regulations are complied with due to the design determined by the intended purpose.

Residual risks can be minimised if the "Safety instructions" and the "Normal intended use" as well as the whole of the operating instructions are observed.

Observing these instructions, and taking proper care, will reduce the risk of personal injury or damage to the equipment.

- **Danger of injury of fingers and hands by the tool (saw blade) or work piece.** Therefore, wear gloves (e.g. when replacing the saw blade).
- **Risk of injury when removing chips while the saw blade still rotates.** Only remove chips after the saw blade and the saw unit (motor) has come to a standstill.
- Injury by catapulted workpiece parts.
- Throwback of the workpiece or workpiece parts.
- Breaking or catapulting of saw blade.
- Only operate the saw with complete and correctly attached safety equipment and do not alter anything on the machine that could impair the safety.
- **Emission of harmful wood dusts.** Therefore, wear a dust mask.



- Risk from electricity, by using non-standard electrical connections.
- Touching live parts of opened electrical components.
- Impairment of hearing when working on the machine for longer periods of time without ear protection.

In addition, in spite of all the precautionary measures taken, non-obvious residual risks can still exist.

Safe working

Woodworking machines can be dangerous if not used properly. If electrical tools are used, the fundamental safety precautions must be met to preclude the risks of fire, electric shock and injuries to persons.

Before starting this device, read and keep to the following advice. Also observe the preventive regulations of your professional association and the safety provisions applicable in the respective country, in order to protect yourself and others from possible injury.

-  Pass the safety instructions on to all persons who work with the machine.
-  Keep these safety instructions in a safe place.

Make yourself familiar with the equipment before using it, by reading and understanding the operating instructions.

Be attentive. Be careful what you do. Behave sensibly when working. Do not use the device when you are tired or under the influence of drugs, alcohol or medicaments. One moment of carelessness when using the device can result in serious injuries.

- Avoid abnormal posture. Provide a safe standing position and keep at any time the balance. Do not lean forward.
- Wear suitable work clothes:
 - do not wear loose-fitting clothes or jewellery; they can catch in moving parts.
 - slip-proof shoes
 - hairnet in case of long hair
- Wear personal protective equipment:
 - ear protection (Sound intensity level at workplace can exceed 85 dB (A))
 - safety goggles
 - gloves when you replacing the saw blade
- ONLY OPERATE the circular saw on a
 - solid
 - level
 - slip-free
 - vibration free surface
- When the saw is connected to a chip exhaustor:
 - Required air flow rate: 1150 m³/h, negative pressure on the suction nozzle 1160 Pa at an air velocity of 20 m/s.
 - Start the chip exhaustor before starting the machining.
- Keep your workplace in an orderly condition! Untidiness can result in accidents.
- Take into consideration environmental influences:
 - Do not expose the saw to rain.
 - Do not use the saw in moist or wet ambience.
 - Provide for good illumination.
 - Do not use this saw near inflammable liquids or gases.
- Never leave the saw unattended.
- Adhere to national regulations that might specify an age limit for the user of the unit.
- Keep other persons away.
The operator is responsible for other people within the working area. Do not allow other persons, especially children, to touch the tool or the cable.
Keep them away from your working area.
- Always stand to the side of the danger zone (saw blade) when working at the bench.
- Start cutting only when the saw blade has reached its required speed.

- Do not overload the machine! You work better and safer in the given performance range.
- The circular saw must only be operated with all the correctly mounted guards. The supplied splitting wedge must be used. Fig. 13 shows how the splitting wedge is inserted and reset.
- Replace the bench insert if the sawing gap is worn.
- Do not use any cracked saw blades or such that have changed their shape.
- Use only well sharpened saw blades as edgeless saw blades increase not only the risk of backstrokes but also charge the motor.
- Do not use saw blades made of high speed steel (HSS) since this steel is hard and brittle; use only tools according to EN 847-1.

 The use of other tools and other accessories can signify a risk of injury for you.

Pay attention that the saw blade conforms to the dimensions specified under "Selection of saw blades" and is suitable for the work piece material.

- Only saw one work piece at a time. Never saw several work pieces at the same time or do not bundle several individual pieces together for cutting. There is danger that individual pieces may be caught by the saw blade in an uncontrolled manner.
- Ensure that cut off pieces are not caught up by the saw blade and projected away
- Do not use the saw for unsuitable purposes (see "Normal intended use").
- Remove all nails and metallic objects from the work piece before sawing.
- Pay attention that the work piece does not contain any cables, ropes, cords or the like.
- Only cut work pieces with dimensions that allow secure holding while sawing.
- Only wood up to a thickness of 15cm is allowed to be cut with this machine.
- When cross cutting round wood it is required to secure the work piece against turning using a pattern or holding device. Use a saw blade that is suited for cross cutting.
- Use a pushing stick when rip sawing narrow workpieces (space between saw blade and rip fence less than 120 mm).
- Always keep sufficient distance to the saw blade. Maintain sufficient distance from driven components during operation.
- The saw blade runs after. Wait until the saw blade has come to a standstill before remove splinters, chips and waste.
- Do not slow the saw blade down by applying lateral pressure to it.
- Do not remove splinters, shavings and waste with your hands from the dangerous area of the saw blade.
- Remove cutting waste from the machine (as required) to prevent any safety impairment at the workplace. This also applies to sawdust. Keep the chip clearance free.
- Switch the machine off and remove the mains plug from the socket when
 - carrying out repair works
 - maintenance and cleaning
 - removal of faults (this also includes the removal of jammed splinters)
 - checks of connecting lines, whether these are knotted or damaged
 - transporting the saw
 - changing the saw blade
 - leaving the saw (also for short-term interruption)
- Maintain your saw with care:
 - Keep your tools sharp and clean in order to be able to work better and safer.
 - Follow the maintenance instructions and the instructions for tool exchange.
 - Keep handles dry and free of oil and grease.
- Check the machine for possible damage:
 - Before further use of the machine the protection devices or slightly damaged parts must be checked carefully for their proper and intended function.
 - Check whether the movable parts function perfectly and do not stick or whether the parts are damaged. All parts must be correctly installed and fulfil all conditions to ensure perfect operation of the saw.

- Damaged guards and parts must be properly repaired or exchanged by a recognized, specialist workshop; insofar as nothing else is stated in the instructions for use.
- Damaged or illegible safety labels should be replaced immediately.
- Do not allow any tool key to be plugged in! Before switching on, check always that wrenches and adjusting tools are removed.
- Store unused equipment in a dry, locked place out of the reach of children.

Electrical safety

- Design of the connection cable according to IEC 60 245 (H 07 RN-F) with a core cross-section of at least
 - 1.5 mm² for cable lengths **up** to 25 m
 - 2.5 mm² for cable lengths **over** 25m
- Long and thin connection lines result in a potential drop. The motor does not reach any longer its maximal power; the function of the device is reduced.
- Plugs and coupler outlets on connection cables must be made of rubber, plasticised PVC or other thermoplastic material of same mechanical stability or be covered with this material.
- Protect yourself against an electric shock. Avoid touching earthed parts with your body.
- The connector of the connection cable must be splash-proof.
- Wind off completely the cable when using a cable drum.
- Do not use the cable for purposes for which it is not meant. Protect the cable against heat, oil and sharp edges. Do not use the cable to pull the plug from the socket.
- Regularly check the saw cable and if damaged, have it renewed by a recognised skilled electrician.
- When running the connection line observe that it does not interfere, is not squeezed, bended and the plug connection does not get wet.
- Regularly check the extension cables and replace them if they are damaged.
- Do not use any defective connection cables.
- When working outdoors, only use extension cables especially approved and appropriately labelled for outdoor use.
- Do not set up any provisional electrical connections.
- Never bypass protective devices or deactivate them.
- Only hook up the machine by means of a fault-current circuit breaker (30 mA).

 The electrical connection or repairs to electrical parts of the machine must be carried out by a certified electrician or one of our customer service points. Local regulations – especially regarding protective measures – must be observed.

 Repairs to other parts of the machine must be carried out by the manufacturer or one of his customer service points.

 Use only original spare parts. Accidents can arise for the user through the use of other spare parts. The manufacturer is not liable for any damage or injury resulting from such action.

Before the first start-up

 To achieve flawless functioning of the machine, please follow the instructions listed:

- Place the saw at a location which meets following conditions:
 - outdoor
 - secured against slipping
 - free of vibrations
 - even
 - free of tripping hazards
 - adequate light

- Check the following prior to use:
 - Defective connecting lines (cracks, cuts, etc.).
⚠ Never use defective lines!
 - Proper working condition of the safety guard.
 - Correct splitting wedge setting (see also Fig. 13).
 - Perfect condition of the saw blade.
 - The push stick must be within easy reach.
- Never use saw blades that are cracked or have become deformed.
- Do not use saw blades made of high-speed steel.
- Always stand to the side of the danger zone (saw blade) when working at the bench.

Start-up

Checking the safety devices

(before each starting):

- Lift and lower the safety guard to check that it can be moved freely. In its rest position it must fully cover the saw blade and rest on the saw table. (See also "Possible faults".)

- Check the switch by turning it on and off.

Do not use any device where the switch can not be switched on and off. Damaged switches must be repaired or replaced immediately by the customer service.

- Brake

The saw blade must stand still within 10 seconds after it was switched off. The brake is defective if this time is exceeded. The saw must then be repaired by the manufacturer or a workshop appointed by the manufacturer.

- Pushstick

⇒ Replace defective pushsticks by new ones.

Rotating direction of the saw blade

- ⓘ Ensure that the rotational direction of the saw blade is the same as the rotational direction given on the guard (15) ↓.



The rotating direction of three-phase motors can be changed by inserting a screwdriver in the connector collar provided for this purpose and turn left or right while exerting a light pressure to adjust the correct rotating direction.

Selection of saw blades

- ⚠ ⇒ Observe the splitting wedge thickness "S"; it is etched into the side of the splitting wedge.

The splitting wedge must not be thinner than the saw blade, and not thicker than the kerf width produced by the blade.

The rating plate specifies maximum and minimum saw blade diameters, as well as the hole diameter.

Do not use saw blades that are designed for a lower max. speed (see identification on the saw blade) than the motor speed (see the technical data).

ⓘ Mains connection

Compare the voltage specified on the rating plate (on the side of the table board), e.g. 230 V, with the mains voltage. Connect the circular saw bench to a correctly earthed socket outlet.

- Alternating-current motor:
Schuko (earthed) socket, mains voltage 230 V, with earth-leakage circuit breaker (FI switch 30 mA).
- Three-phase motor:
CEE socket, 3-pin + N + PE, mains voltage 380 V or 400 V, with earth-leakage circuit breaker (FI switch 30 mA).

Use connecting and extension cables in conformity with IEC 60245 (H 07 RN-F) with a conductor cross-section of at least:

- -1.5 mm² for a cable length of **up to** 25 m.
- -2.5 mm² for a cable length **exceeding** 25 m.

ⓘ Main fuse: 16 A inert

On/Off switch

Switching on



- Open the switch cover.
- Press the green button (I)



The device cuts off automatically in case of power failure. To restart, first push the red button (O) and then again the green button (I).

Switching off



Press the red button (O) or the red button of the yellow switch cover.

Single-phase variant (230 V)



Three-phase variant (400 V)

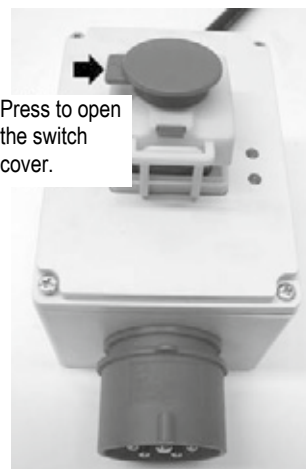

Press to open the switch cover.

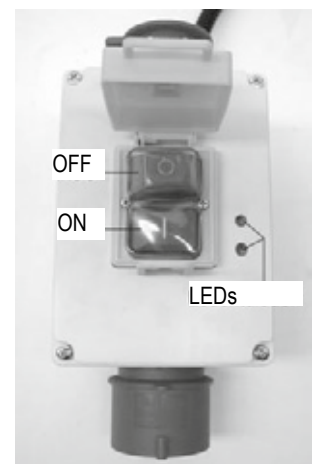

LEDs

LEDs on

→ The motor is switched on - the saw blade rotates.

LEDs off

→ The motor is switched off - the saw blade stands still.

Only one LED is on:

- 1) One phase has failed: Have the supply line checked immediately by an electrician.
- 2) LED module (361642) defective: Have it replaced immediately by an electrician.

Working with the saw

! You may not start to operate the machine until you have read these operating instructions, observed all the instructions given and installed the machine as described!

! Before making adjustments to the saw settings (e.g. replacing the saw blade etc.)

- switch off device
- wait for standstill of the saw blade.
- pull out power plug

! Also, note the following important points:

- Place yourself outside of the area of danger.
- Cut through the piece with uniform pressure.
- Never remove loose splinters, chips and the like with the hands. Make sure that the saw blade stands still before removing such material.

! At any case pay attention to all safety instructions.

Working instructions

The parallel stop can be adjusted in arrow direction.

It is secured by cam levers.

To unclamp: Press the lever towards the saw.

To clamp: Pull toward the opposite direction.

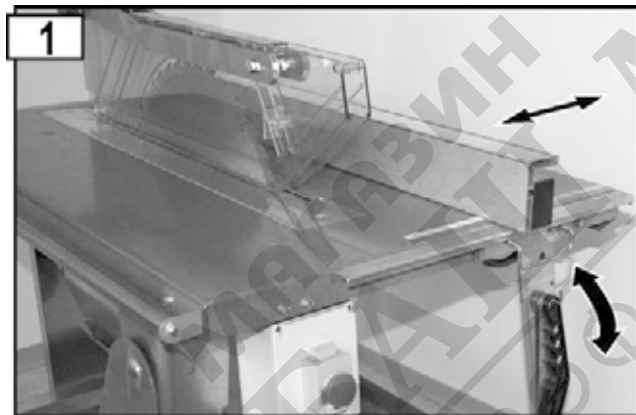

Folding out the table extension

Fold up the table extension. Move the table extension in arrow direction and lower it. Make sure that the table extension is correctly hooked.

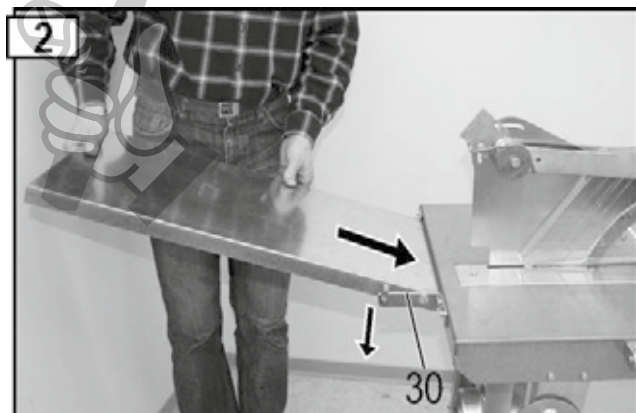

Cutting solid wood lengthwise



Parallel stop as stop for cross cuts

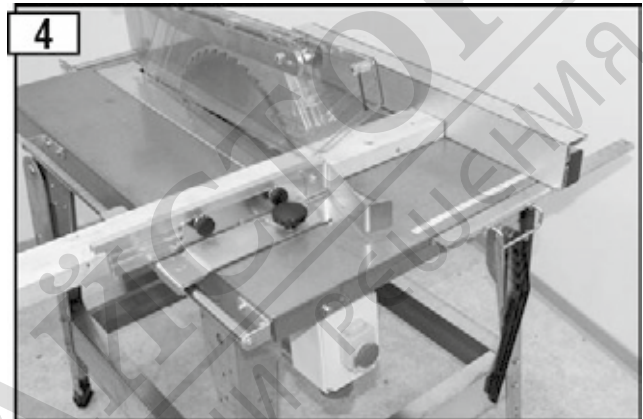

Cutting wedges using the wedge cutting stop

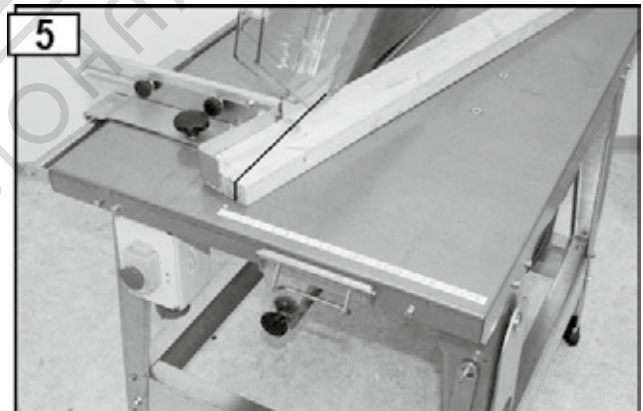

Using the pushstick

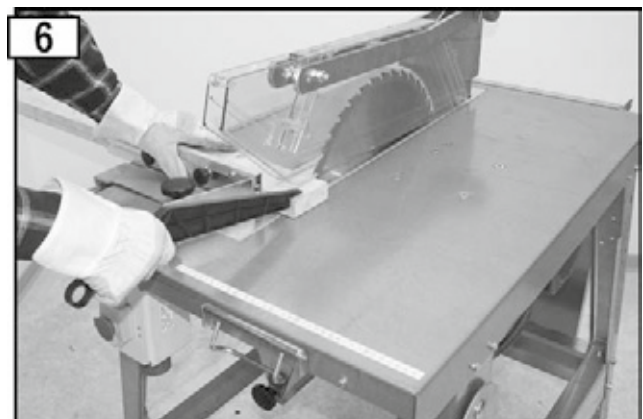

Using the movable cross stop

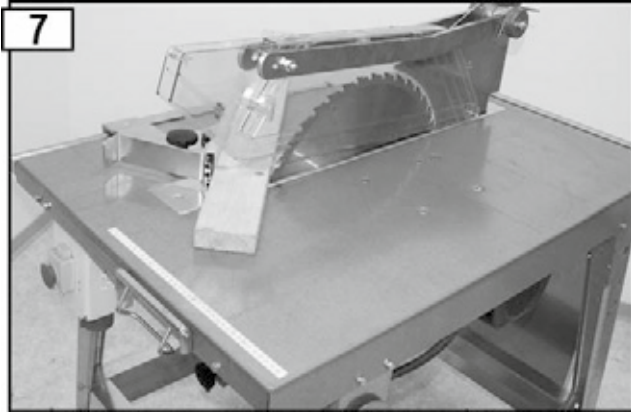

Connecting a chip extractor

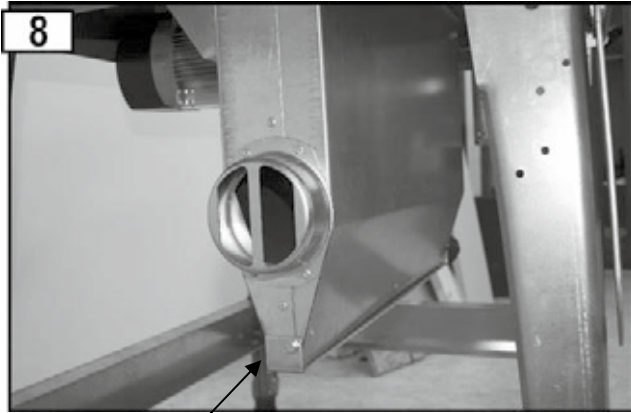

Chip ejector slot closed (operation with chip extractor)

A chip extractor can be connected to the saw to extract the chips. (Diameter of extractor nozzle: 100 mm.) Close the sealing blade on the chip ejector slot and secure it using the machine knob.

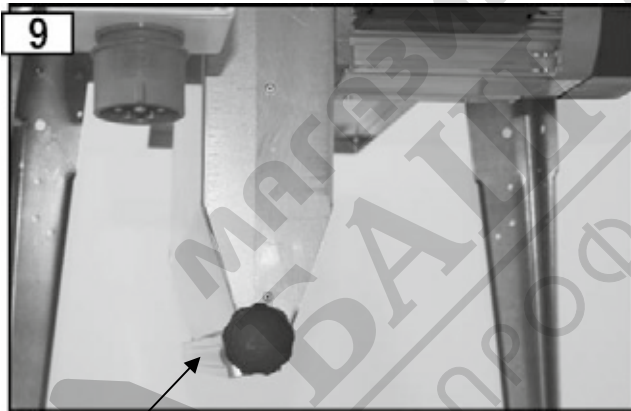

Chip ejector slot open (operation without chip extractor)

Maintenance and cleaning



Before each maintenance and cleaning work

- Switch off device
- Wait until the saw blade comes to a stop.
- Pull out power plug

Maintenance and repair work other than those described in this chapter is only allowed to be carried out by service staff.

For maintaining and cleaning, removed security devices must unconditionally be mounted properly and proved again.

Use only original parts. Other parts can result in unexpected damages and injuries.

Cleaning

- ⓘ **Observe the following to maintain the operability of the machine:**
 - Do not wash down device with water.
 - Remove shavings and dust only with a brush or vacuum cleaner.
 - **Regularly** clean and oil all movable parts (e.g. fasteners of the guard). Fig. 10

ⓘ Never use any grease!

👉 Use for instance sewing machine oil, liquid hydraulic fluid or environmentally acceptable spray oil.

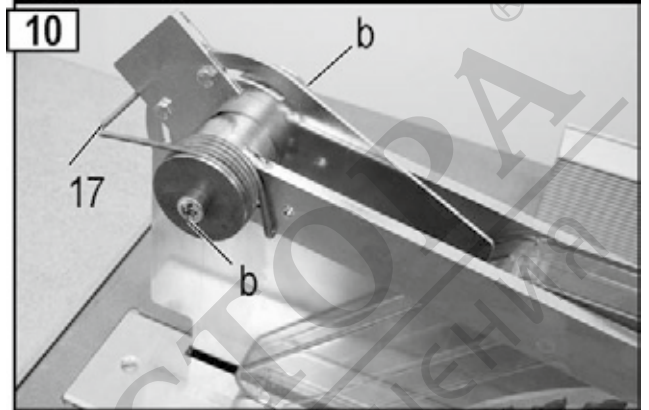

- Take care that the saw blade remain free of rust and resin.
- Resin residues must be removed from the table board.
- ⓘ Resin residues can be removed with a commercial maintenance and care spray.
- The saw blade is a wearing part and will become dull after prolonged or frequent use.
- 👉 Renew the saw blade or have it sharpened.

Maintenance

🔧 Changing the saw blade



Remove the mains plug before changing the saw blade.

- ⚠ **Danger of cutting! The saw blade is massive and it could be to slick. Wear gloves when replacing the saw blade.**
 - Do not use any saw blades made of HSS steel.
 - Do not use any cracked saw blades or such that have changed their shape.
 - Saw blades the body of which is broken must be discarded (no repair allowed).
 - Only use well-sharpened saw blades.
 - Regrinding (sharpening) of saw blades is only allowed to be done by qualified personnel. In particular note the following: Make sure that the requirements for balancing of the tools according to EN 847-1:2005+A1:2007 6.2.3.2 are met.
- ⚠ **Danger of burning! The saw blade is still hot shortly after cutting.**
 1. Fold the safety guard backwards.
 2. Loosen the screws of the table insert and move it back.

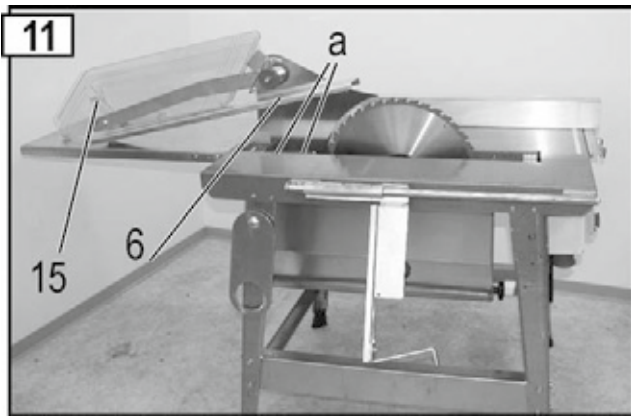

3. Insert rod (33) into motor-shaft and unscrew bolt (⚠ left-hand-thread)

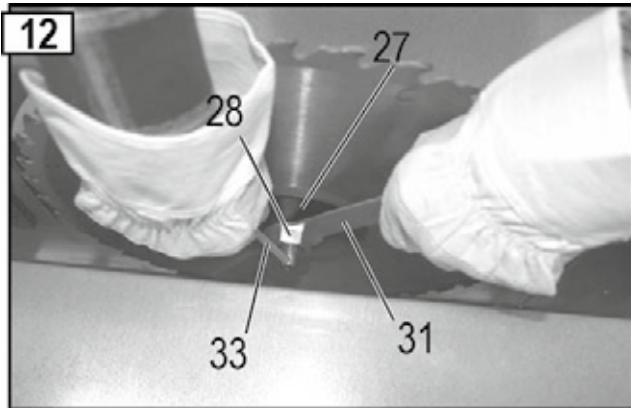

4. Now, the front saw blade flange (27) and the saw blade (26) can be removed.
5. ⓘ Clean the saw blade flanges.
6. Install a new or sharpened saw blade.
- ⓘ Pay attention to the correct running direction of the saw blade: The arrow on the saw blade and the arrow on the protective cover must point in the same direction!
7. Position the front saw blade flange again.
8. Re-tighten the clamping nut (28).
9. Secure the table insert.
10. Fold the safety guard back to its original position.

🔧 Replacing the table insert

⚠️ ⚡️ Disconnect the mains plug before changing the table insert.

- ⚠️ Immediately replace a worn or damaged table insert.
1. Fold back the safety guard (15).
 2. Loosen the screws of the table insert (6) and move it back.
 3. Remove the 2 nuts (a) and remove the blade guard (12) together with the safety guard.
 4. Install a new table insert (6).
 5. Secure the blade guard with the safety guard (for blade guard adjustment see figure 13).
 6. Secure the table insert.
 7. Fold the safety guard back to its original position.

Blade guard adjustments

The adjustment of the blade guard must be checked after each saw blade and table insert change.

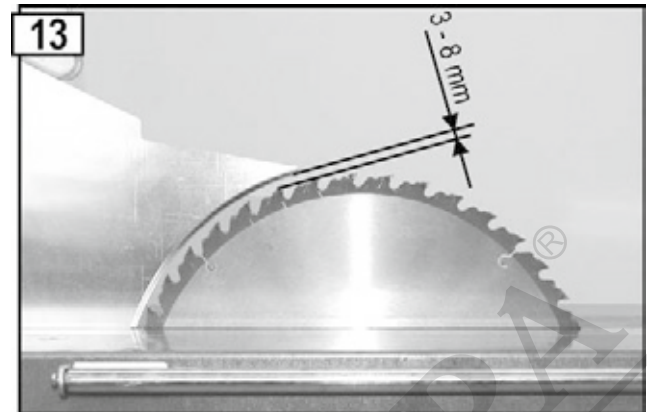

Transport



Before each transport:

- Switch off device
- Wait until the saw comes to a stop.
- Pull out power plug
- Accessories such as stops must be securely mounted or clamped on the machine.



Storage



Pull out power plug

- Store unused equipment in a dry, locked place out of the reach of children.
- Before a longer period of storage carry out the following to extend the saw service life and ensure an easy operating:
 - thoroughly clean the device
 - treat all movable parts with an environmentally friendly oil

ⓘ Never use any grease!

Guarantee

Please observe the enclosed terms of guarantee.

Possible faults



Before each fault elimination:

- Switch off device
- Wait until the saw comes to a stop.
- Pull out power plug

After each fault clearance, put into operation and recheck all security installations.

Fault	Possible cause	Remedy
Machine fails to start after switching on	<ul style="list-style-type: none"> • Power failure • Extension cable defect • Motor or switch defect 	<ul style="list-style-type: none"> • Check the fuse. • Check cable, no longer use defect cable • Have motor or switch checked by an approved electrician or replaced by original spare parts
Machine stops while cutting	<ul style="list-style-type: none"> • Saw blade blunt • Feed is too great 	<ul style="list-style-type: none"> • Replace saw blade (26) • Allow motor to cool and proceed working with less pressure
Burned spots at the cut areas	<ul style="list-style-type: none"> • Saw blade blunt 	<ul style="list-style-type: none"> • Replace saw blade
Saw vibrates	<ul style="list-style-type: none"> • Saw blade is warped • Saw blade not properly mounted 	<ul style="list-style-type: none"> • Replace saw blade • Mount saw blade properly
Deceleration too slow (time to dead stop >10 sec.)	<ul style="list-style-type: none"> • Motor brake defective • Brake disk worn 	<ul style="list-style-type: none"> • Have motor or switch checked by an approved electrician or replaced by original spare parts
Motor generates insufficient power and becomes too hot.	<ul style="list-style-type: none"> • Three-phase motor is running on the second phase. • Extension cable too long or cable cross-section too small. • Blunt saw blade. 	<ul style="list-style-type: none"> • The fuses and the supply lines must be checked by an electrician. • See "Setting into Operation". • The saw blade must be resharpened or replaced
Safety guard not freely movable	<ul style="list-style-type: none"> • Screws excessively tightened. 	<ul style="list-style-type: none"> • Loosen the screws to the extent that the safety guard can be moved (Fig. 10).

Technical data

Typ	BTU 450	
Mains voltage	230 V~	400 V 3~
Mains frequency	50 Hz	
Motor rating P ₁	3,0 kW - S 6 - 40 %	4,4 kW - S 6 - 40 %
Motor output P ₂	2,2 kW - S 6 - 40 %	3,5 kW - S 6 - 40 %
No-load speed	2698 min ⁻¹	2790 min ⁻¹
Carbide tipped saw blade	Ø 450 x 2,8/3,8 x Ø 30 mm 40 teeth	
Saw blade - Ø max./min.	445 - 450 mm	
Cutting depth	Ca. 150mm	
Table size	1000 x 660 mm	
Table height	850 mm	
Weight	Ca. 90 kg	
Width of the guide elements for the blade guard	12 mm	
Blade guard:	Width of guide slot	12,1 mm
	Thickness	3 mm
Connection diameter for suction fitting	100 mm	
Mains fuse	16 A inert	
Protection class	IP 54	

Description of device / spare parts

Pos.	Order-No.	Denomination
1	361685	Saw table board
2	361622	Table leg
3	360104	Slip-on foot
4	361691	Brace, long
5	361690	Brace, short
6	361025	Table insert
7	361026	Transport lug
8	361109	Tool hook
9	361722	Chip box, cpl.
10	361157	Extractor connecting piece
11	361162	Sealing blade
12	361694	Splitting wedge
13	361634	Guard holder, cpl.
14	361703	Adjusting device
15	361625	Protective guard
16	360528	Clamping device, cpl.
17	361702	Double torsion spring
18	361735	Parallel stop without guide ruler
19	361680	Stop ruler (aluminium)
20	361684	Stop guide
21	360005	Stop angle, cpl.
22	361313	Stop bar
23	361314	Wedge cutting stop
24	361682	Holder
25	361687	Guide shaft
26	360213	Carbide tipped saw blade
27	361635	Saw blade flange, front (Fig. 12)

Pos.	Order-No.	Denomination
28	391035	Clamping nut M 20, LH (Fig. 12)
29	362503	Table extension
30	362506	Swiveling holder LH for table extension (Fig. 2)
	362505	Swiveling holder RH for table extension
31	361112	Ring wrench size 30/19 (Fig. 12)
32	361110	Push stick
33	361111	Retaining pin (pivot pin) (Fig. 12)
	361641	Three-phase motor
	361637	Single-phase motor
	360874	Switch base for three-phase power supply
	360145	Switch base for single-phase power supply

Spare parts

Identify the required spare part from the spare parts drawing and list.

Ordering spare parts:

⇒ The parts are procured from the manufacturer.

⇒ Required details for orders:

- Type of saw
- Saw number (see rating plate)
- Spare part number
- Designation of the spare part
- Quantity

Example: Type BTU 450, product no. 4128, 360213 carbide tipped saw blade, 1 piece

