

ELECTRIC TOOL PARTS LIST

HAND GRINDER
Model GP 2S2

2010·4·22
(E1)

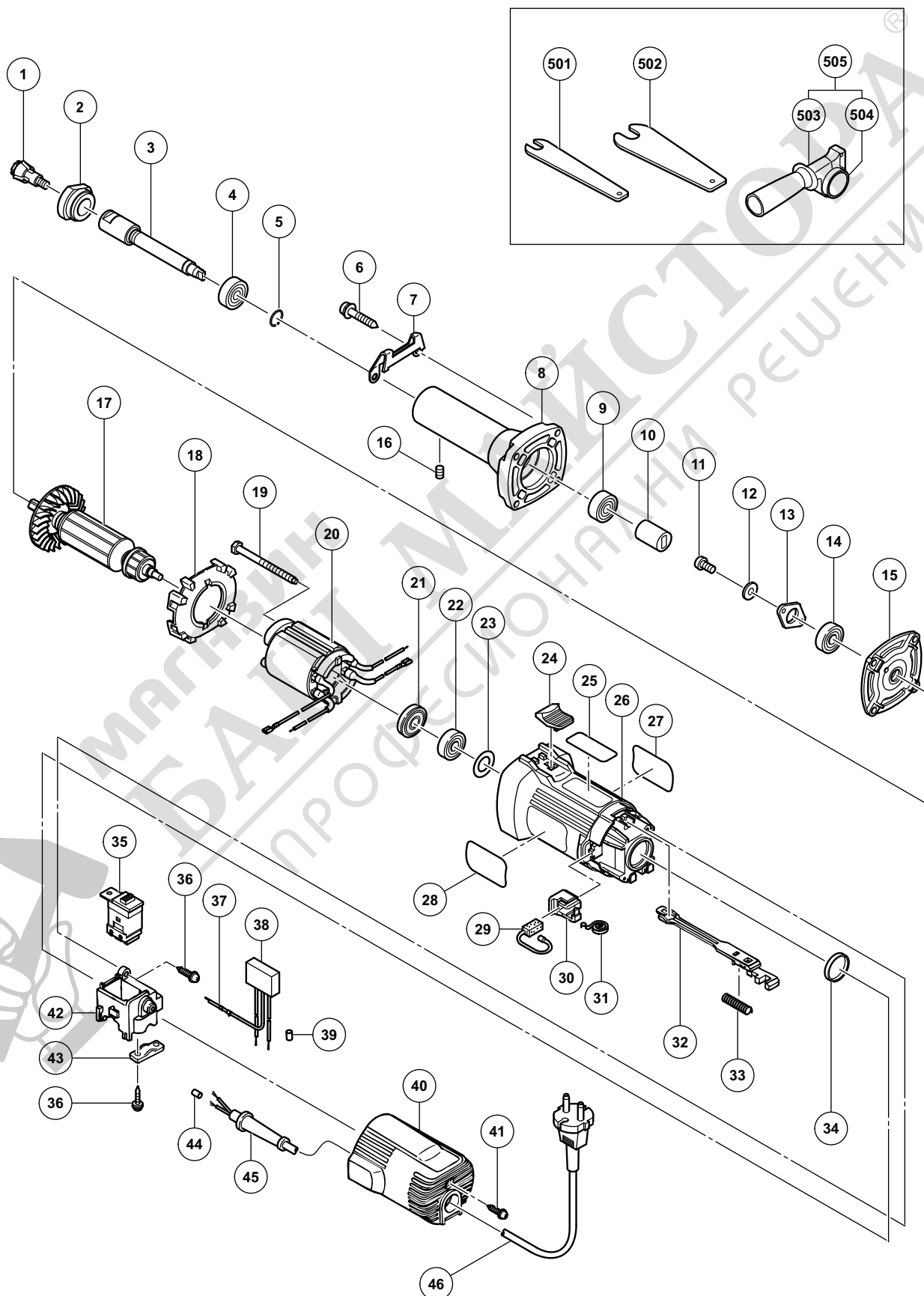

PARTS

GP 2S2

ITEM NO.	CODE NO.	DESCRIPTION	NO. USED	REMARKS	
*	1	331-421	COLLET CHUCK 6MM	1	
*	1	331-422	COLLET CHUCK 1/4"	1	FOR USA, CAN, MEX, PAN (120V), AUS
	2	332-452	BEARING LID (B)	1	
	3	332-453	SPINDLE	1	
	4	600-1VV	BALL BEARING 6001VVCMP2L	1	
	5	932-617	RING	1	
	6	986-011	TAPPING SCREW (W/SP. WASHER) D5 X 30	4	
	7	317-807	GUARD PLATE	1	
	8	331-474	NOSE BRACKET	1	
	9	600-0VV	BALL BEARING 6000VVCMP2L	1	
	10	985-140	COUPLING	1	
	11	987-201	SEAL LOCK SCREW (W/SP. WASHER) M4 X 10	2	
	12	949-453	SPRING WASHER M4 (10 PCS.)	2	
	13	937-876	BEARING COVER	1	
	14	608-VVM	BALL BEARING 608VVC2PS2L	1	
	15	331-475	INNER COVER	1	
	16	981-478	HEX. SOCKET SET SCREW M4 X 4	1	
*	17	360-879U	ARMATURE ASS'Y 110V-120V	1	INCLUD. 14, 21, 22
*	17	360-879E	ARMATURE 220V-230V	1	
*	17	360-879F	ARMATURE 240V	1	
	18	319-898	FAN GUIDE	1	
	19	982-021	HEX. HD. TAPPING SCREW D4 X 70	2	
*	20	340-758C	STATOR (A) 110V-120V	1	
*	20	340-758G	STATOR ASS'Y (A) 110V	1	FOR GBR (110V)
*	20	340-758M	STATOR (A) 110V	1	FOR TPE
*	20	340-758E	STATOR (A) 220V-230V	1	
*	20	340-758H	STATOR (A) 230V	1	FOR NZL
*	20	340-758F	STATOR (A) 240V	1	
*	20	340-758L	STATOR (A) 240V	1	FOR AUS
	21	315-877	DUST SEAL	1	
	22	608-VVM	BALL BEARING 608VVC2PS2L	1	
	23	332-804	WASHER M14	1	
	24	314-428	SLIDE KNOB	1	
	25		CAUTION PLATE	1	
	26	317-802	HOUSING	1	
	27		NAME PLATE	1	
	28		HITACHI LABEL	1	
	29	999-088	CARBON BRUSH (1 PAIR)	2	
	30	317-810	BRUSH HOLDER	2	
	31	308-536	SPRING	2	
	32	317-806	SLIDE BAR	1	
	33	314-429	SPRING	1	
	34	995-662	RUBBER RING	1	
*	35	332-805	SLIDE SWITCH (2P PILLAR TYPE)	1	
*	35	321-208	SLIDE SWITCH (2P PILLAR TYPE)	1	FOR USA, CAN
	36	984-750	TAPPING SCREW (W/FLANGE) D4 X 16	3	
	37	314-854	EARTH TERMINAL	1	
	38	325-566	NOISE SUPPRESSOR	1	
	39	981-373	TUBE (D)	2	
	40	317-808	TAIL COVER	1	

