

## ELECTRIC TOOL PARTS LIST

### RECIPROCATING SAW Model CR 13V2

2009·5·26  
(E1)

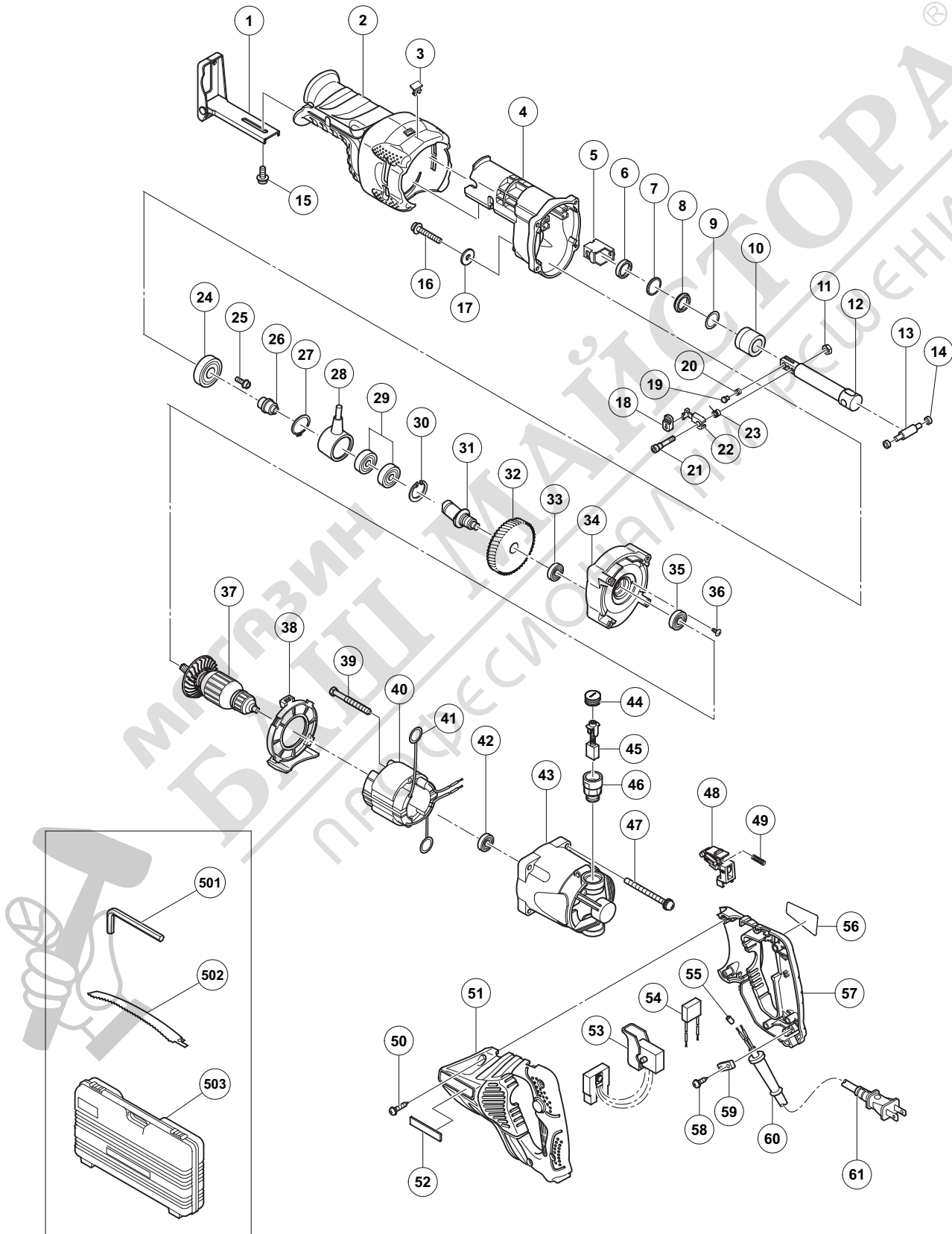

**PARTS**

CR 13V2

ITEM NO.	CODE NO.	DESCRIPTION	NO. USED	REMARKS
1	330-833	BASE (F)	1	
2	330-821	FRONT COVER (F)	1	
3	330-834	COVER PIN	1	
4	330-818	GEAR COVER (F)	1	
5	326-589	BLADE HOLDER (C)	1	
6	318-458	FELT WASHER	1	
7	321-117	WASHER (H)	1	
8	318-459	V-RING	1	
9	321-118	O-RING	1	
10	321-214	METAL (B)	1	
11	949-566	LOCK NUT M5 (10 PCS.)	1	
12	330-828	PLUNGER (F)	1	
13	330-829	CONNECTOR PIN (F)	1	
14	321-136	SWING ROLLER	2	
15	322-142	NYLOCK BOLT (W/FLANGE) M5 X 12	1	
16	318-451	NYLOCK BOLT (W/FLANGE) M6 X 35	1	
17	318-452	WASHER (G)	1	
18	321-130	CAP	1	
19	321-134	HOLDER PIN (B)	1	
20	318-483	SPRING (B)	1	
21	326-590	SPECIAL BOLT M5	1	
22	326-588	LEVER (C)	1	
23	326-591	BLADE SPRING	1	
24	600-2DD	BALL BEARING 6002DDCMPS2L	1	
25	317-196	NYLOCK BOLT (W/FLANGE) M4 X 12	3	
26	322-119	SUB SHAFT (B)	1	
27	967-261	RETAINING RING FOR D17 SHAFT	1	
28	330-830	RECIPRO PLATE (F)	1	
29	327-694	BALL BEARING 6003VVCM (NYLON RETAINER)	2	
30	939-556	RETAINING RING FOR D35 HOLE (10 PCS.)	1	
31	330-831	SECOND SHAFT (F)	1	
32	330-832	GEAR (F)	1	
33	608-VVM	BALL BEARING 608VVC2PS2L	1	
34	330-819	INNER COVER (F)	1	
35	600-1VV	BALL BEARING 6001VVCMP2S2L	1	
36	314-430	SLOTTED HD. SCREW (SEAL LOCK) M4 X 10	2	
* 37	360-872C	ARMATURE 110V	1	
* 37	360-872U	ARMATURE ASS'Y 120V	1	INCLUD. 35, 42
* 37	360-872E	ARMATURE 220V-230V	1	
* 37	360-872F	ARMATURE 240V	1	
38	330-820	FAN GUIDE (F)	1	
39	953-174	HEX. HD. TAPPING SCREW D5 X 55	2	
* 40	340-751C	STATOR ASS'Y 110V	1	INCLUD. 41
* 40	340-751D	STATOR ASS'Y 120V	1	INCLUD. 41
* 40	340-751E	STATOR ASS'Y 220V-230V	1	INCLUD. 41
* 40	340-751G	STATOR ASS'Y 220V	1	INCLUD. 41 FOR CHN, HKG, KOR, THA
* 40	340-751F	STATOR ASS'Y 240V	1	INCLUD. 41
41	930-703	BRUSH TERMINAL	2	
42	608-VVM	BALL BEARING 608VVC2PS2L	1	
43	330-817	HOUSING	1	

**PARTS**

CR 13V2

ITEM NO.	CODE NO.	DESCRIPTION	NO. USED	REMARKS	
44	945-161	BRUSH CAP	2		
*	45	999-043	CARBON BRUSH (1 PAIR)	2	
*	45	999-056	CARBON BRUSH (1 PAIR)	2	FOR HKG, USA, CAN, MEX, THA
	46	958-900	BRUSH HOLDER	2	
	47	307-224	MACHINE SCREW (W/WASHERS) M5 X 60 (BLACK)	4	
	48	330-835	OFF LOCK LEVER	1	FOR AUS, NZL
	49	330-839	SPRING (F)	1	FOR AUS, NZL
	50	307-028	TAPPING SCREW (W/FLANGE) D4 X 25 (BLACK)	5	
*	51	330-826	HANDLE (H)	1	
*	51	330-827	HANDLE (H)	1	FOR AUS
	52		HITACHI LABEL	1	
*	53	330-837	SWITCH 110V-120V	1	
*	53	330-838	SWITCH 220V-240V	1	
*	54	930-039	NOISE SUPPRESSOR	1	EXCEPT FOR HKG, USA, CAN, MEX, THA
	55	981-373	TUBE (D)	2	
	56		NAME PLATE	1	
*	57	330-823	HANDLE (G)	1	
*	57	330-824	HANDLE (G)	1	FOR AUS
	58	984-750	TAPPING SCREW (W/FLANGE) D4 X 16	2	
	59	937-631	CORD CLIP	1	
*	60	953-327	CORD ARMOR D8.8	1	
*	60	938-051	CORD ARMOR D10.1	1	
*	61	500-234Z	CORD	1	(CORD ARMOR D8.8)
*	61	500-247Z	CORD	1	(CORD ARMOR D8.8) FOR FIN, DEN, SWE, NOR
*	61	500-435Z	CORD	1	(CORD ARMOR D8.8) FOR GBR (230V), HKG
*	61	500-461Z	CORD	1	(CORD ARMOR D8.8) FOR GBR (110V)
*	61	500-434Z	CORD	1	(CORD ARMOR D8.8) FOR USA, CAN, MEX
*	61	500-439Z	CORD	1	(CORD ARMOR D8.8) FOR AUS, NZL
*	61	500-455Z	CORD	1	(CORD ARMOR D8.8) FOR CHN, THA
*	61	500-447Z	CORD	1	(CORD ARMOR D8.8) FOR TUR
*	61	323-974	CORD	1	(CORD ARMOR D10.1) FOR TPE

**STANDARD ACCESSORIES**

CR 13V2

ITEM NO.	CODE NO.	DESCRIPTION	NO. USED	REMARKS
501	944-458	HEX. BAR WRENCH 4MM	1	
* 502	327-129	SABER SAW BLADES NO.341 150L P.14 (3 PCS.)	1	
* 502	318-621	SABER SAW BLADES NO.132 203L (5 PCS.)	1	FOR USA, CAN
503	327-054	CASE	1	

**OPTIONAL ACCESSORIES**

ITEM NO.	CODE NO.	DESCRIPTION	NO. USED	REMARKS
601	959-610	SABER SAW BLADES NO.1 (5 PCS.)	1	
602	958-182	SABER SAW BLADES NO.2 (5 PCS.)	1	
603	958-183	SABER SAW BLADES NO.3 (5 PCS.)	1	
604	959-611	SABER SAW BLADES NO.4 (5 PCS.)	1	
605	958-185	SABER SAW BLADES NO.5 (5 PCS.)	1	
606	958-188	SABER SAW BLADES NO.8 (5 PCS.)	1	
607	996-427	SABER SAW BLADES NO.9 (3 PCS.)	1	
608	318-611	SABER SAW BLADES NO.101 150L P.10 (5 PCS.)	1	
609	318-612	SABER SAW BLADES NO.102 228L P.10 (5 PCS.)	1	
610	318-613	SABER SAW BLADES NO.103 150L P.14 (5 PCS.)	1	
611	318-614	SABER SAW BLADES NO.104 228L P.14 (5 PCS.)	1	
612	318-617	SABER SAW BLADES NO.107 150L P.24 (5 PCS.)	1	
613	318-618	SABER SAW BLADES NO.108 228L P.24 (5 PCS.)	1	
614	324-818	SABER SAW BLADES NO.109 150L P.18 (5 PCS.)	1	
615	324-819	SABER SAW BLADES NO.110 228L P.18 (5 PCS.)	1	
616	318-619	SABER SAW BLADES NO.121 305L P.6 (5 PCS.)	1	
617	318-620	SABER SAW BLADES NO.131 305L P.10/14(5 PCS.)	1	
618	318-621	SABER SAW BLADES NO.132 203L (5 PCS.)	1	
619	330-852	CUT-OFF GUIDE ASS'Y (L)	1	INCLUD. 620-632
620	996-423	NUT LEVER	1	
621	996-422	CHAIN BOLT	1	
622	996-421	GUIDE BAR	2	
623	996-424	SLIDE PLATE	1	
624	949-755	HEX. SOCKET HD. BOLT M6 X 16 (10 PCS.)	2	
625	321-427	PLATE (B)	1	
626	321-428	BASE SLEEVE	2	
627	949-665	HEX. SOCKET HD. BOLT M5 X 14 (10 PCS.)	2	
628	949-755	HEX. SOCKET HD. BOLT M6 X 16 (10 PCS.)	2	
629	949-425	WASHER M6 (10 PCS.)	2	
630	944-458	HEX. BAR WRENCH 4MM	1	
631	944-459	HEX. BAR WRENCH 5MM	1	
632	330-833	BASE (F)	1	