



Makita Werkzeug Ges.m.b.H.

Kolpingstrasse 13, 1230 Wien

Tel: 01 / 616 27 30 - 0*

Fax: 01 / 616 27 30 - 40

Mail: verkauf@makita.at

Web: www.makita.at

Makita Service Information / Model: HP1640

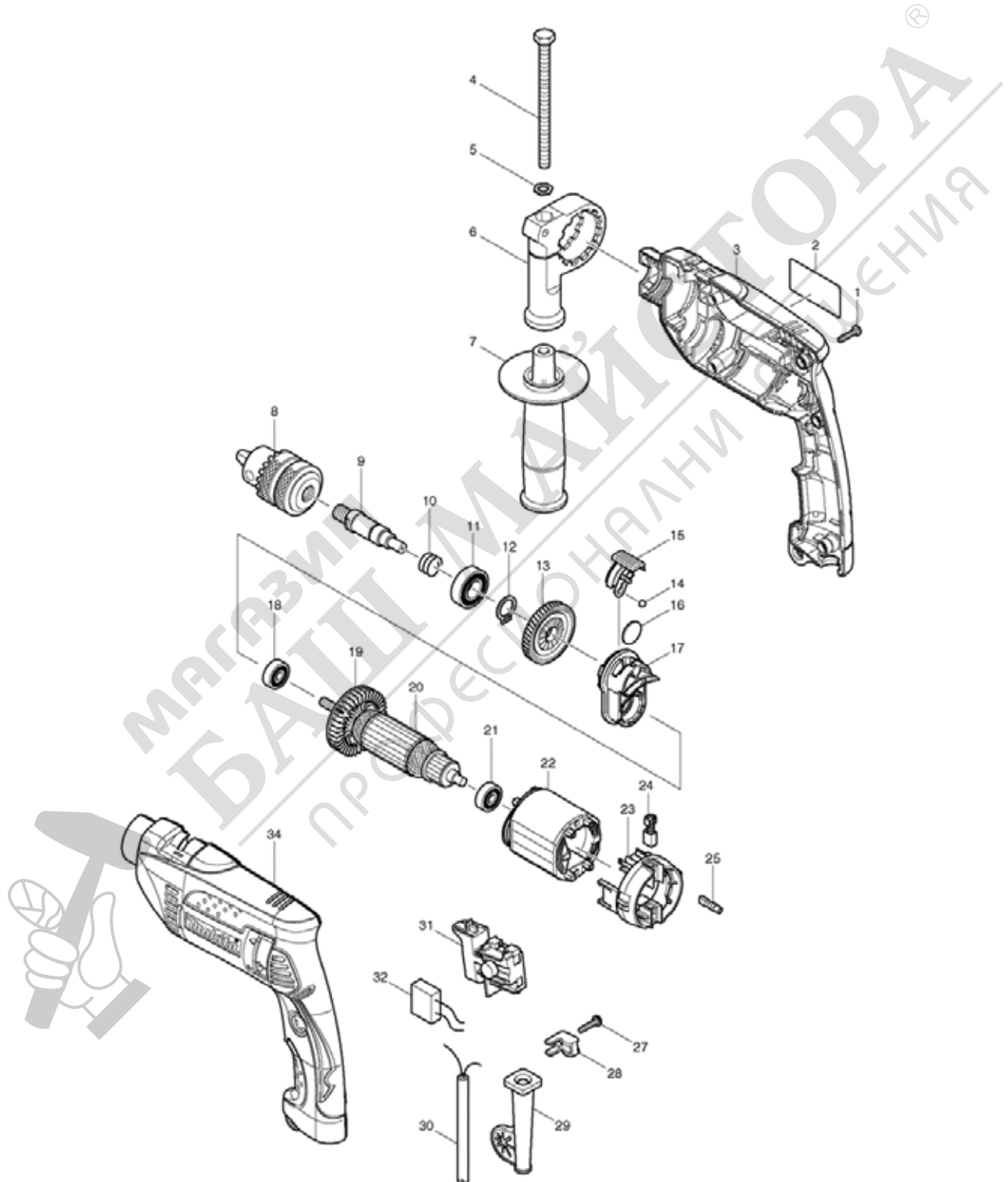



Makita Werkzeug Ges.m.b.H.

Kolpingstrasse 13, 1230 Wien

Tel: 01 / 616 27 30 - 0*

Fax: 01 / 616 27 30 - 40

Mail: verkauf@makita.at

Web: www.makita.at

Makita Service Information / Model: HP1640

POS	Bestell-Nr.	Artikelbeschreibung	Stk.	Stk.Preis
1	265995-6	SELBSTSCHN.SCHRA 4x18 BO5030	7	N/A
2	866001-6	HP1640 NAME PLATE	1	N/A
3	188611-2	GEHÄUSE KPL. HP1640	1	N/A
3		*** INC. 34		N/A
4	265583-9	6-KANTSCHRAUBE M8x120 HP1620	1	N/A
5	345280-4	SCHEIBE HP-F/HR-F Serie	1	N/A
6	417630-4	GRIFFHALTER HR2440/2020/2450F	1	N/A
7	152489-9	SEITL.GRIFF 36 HP1641	1	N/A
8	766016-2	DRILL CHUCK S13	1	N/A
8	763142-8	ORIG.ZK-FUTTER 13MM HP1640	1	N/A
8.2	766016-2	DRILL CHUCK S13	1	N/A
9	324397-6	SPINDEL HP1620/1621	1	N/A
10	233389-3	DRUCKFEDER 15 HP1641	1	N/A
11	211201-7	KUGELLAGER 6002LLB HP1641	1	N/A
12	961055-9	SEGERRING S-15 HP1641	1	N/A
13	226579-5	ZAHNRAD 45 HP1620/1621	1	N/A
14	216018-3	STAHLKUGEL 5.0 BFL/BFT	1	N/A
15	418319-7	UMSCHALTHEBEL HP1620/1621	1	N/A
16	345354-1	PLATTE 19 HP1620/1621	1	N/A
17	141165-0	KUPPLUNGHALTER HP1620/1621	1	N/A
17	153831-7	KUPPLUNGHALTER HP1620/1621	1	N/A
17.2	141165-0	KUPPLUNGHALTER HP1620/1621	1	N/A
18	210023-2	KUGELLAGER 627DDW BHR241	1	N/A
19	240067-8	LÜFTERRAD 55 HP1620/1621	1	N/A
20	517458-1	ANKER HP1620/1621	1	N/A
20		*** INC. 18,19,21		N/A
21	211028-5	KUGELLAGER 627LB HP1641	1	N/A
22	633568-7	FELD HP1620/1621	1	N/A
23	638237-5	KOHLLENHALTER EINHEIT HP1620/21	1	N/A
24	191962-4	KOHLLEN CB-419(CB-406/407)hp164	1	N/A
25	686038-5	FAHNENSTECKER HP1620/21/HP2070	2	N/A
27	265995-6	SELBSTSCHN.SCHRA 4x18 BO5030	1	N/A
28	687260-7	HALTERUNG GA5020/6020/HR2230/	1	N/A
29	682549-8	KABELSCHUTZ HP1640	1	N/A
30	665383-1	KABEL 1.0-2-2.0 HP1630/1631K	1	N/A
31	650570-5	SCHALTER HR1830/F	1	N/A
32	645267-9	KONDENSATOR HP1641	1	N/A
32	645200-1	KONDENSATOR HP1641	1	N/A
32.2	645267-9	KONDENSATOR HP1641	1	N/A
34	188611-2	GEHÄUSE KPL. HP1640	1	N/A



Makita Werkzeug Ges.m.b.H.

Kolpingstrasse 13, 1230 Wien

Tel: 01 / 616 27 30 - 0*

Fax: 01 / 616 27 30 - 40

Mail: verkauf@makita.at

Web: www.makita.at

Makita Service Information / Model: HP1640

POS	Bestell-Nr.	Artikelbeschreibung	Stk.	Stk.Preis
34		*** INC. 3		N/A
1001	324219-0	TIEFENANSCHLAG HR2020/2440/50F	1	N/A
1002	763440-0	BF-SCHLÜSSEL 13MM HP2040/HP15	1	N/A
1002	763448-4	BF-SCHLÜSSEL S13 MT811/HP1630	1	N/A
1002.2	763448-4	BF-SCHLÜSSEL S13 MT811/HP1630	1	N/A
1003	821549-5	MAKPAC TYPE 1 395x295x105mm	1	N/A
1003	824724-2	TRANSPORTKOFFER 8450K/HP1620K	1	N/A
1003.2	824923-6	TRANSPORTKOFFER 8450K/HP1620K	1	N/A
1004	837666-1	INNER TRAY	1	N/A
1005	801C90-2	HP1640J INDICATION LABEL	1	N/A
1006	801C91-0	HP1640J PLASTIC CASE LABEL	2	N/A



МАГАЗИН
БАШ МАЙСТРА
ПРОФЕСИОНАЛНИ РЕШЕНИЯ