	TECHNICAL DATA SHEET	Reference	FT ROS
		Date	26/02/14
		Revision	2
		Page	1 of 13
Denomination: SELF TAPPING SCREW		Codes	T81, TA281, T81C, TA281C, T82, TA282, T82C, TA282C, T83, AUE, TCPZ, TPCN, TCPA2, TFI

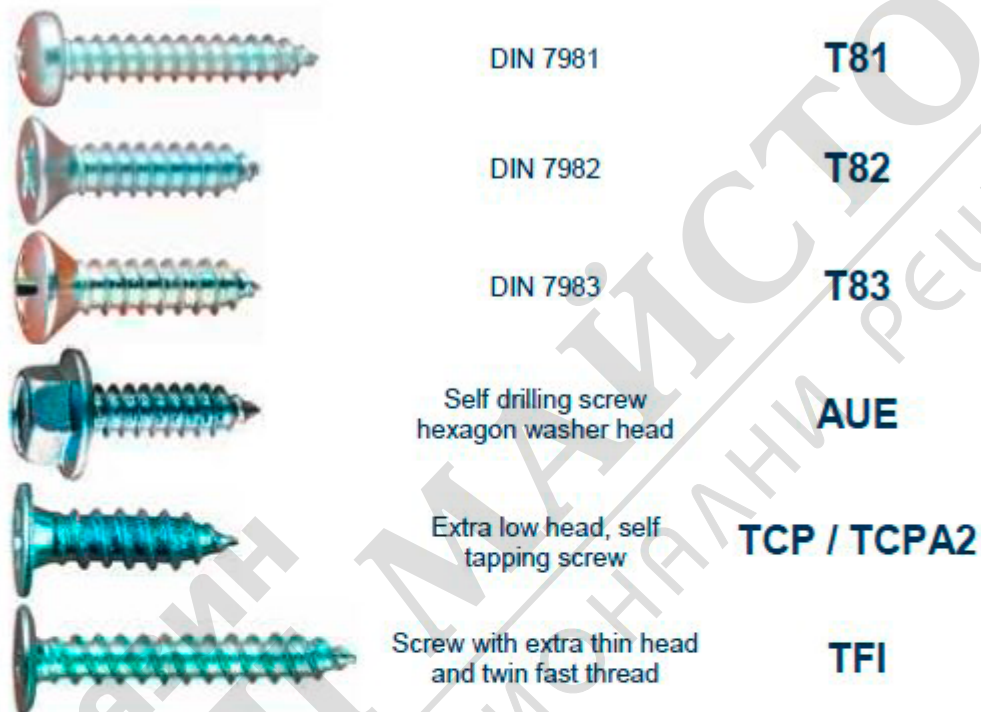

1. CHARACTERISTICS

- Metallic elements joint each other, or PVC, wood or another material with metallic materials.
- Self tapping screw ISO 1478
- Previous hole is required.
- F end (except DIN 7981 lead point)
- EPDM steel zinc plated washer version for waterproof unions in fronts and roofs.
- Wide variety in heads, diameters, and lengths for different applications : flexibility in assembly
- Zinc plated or black zinc plated.
- Stainless steel versions available.
- RAL Colored versions
- Cups for hexagon heads available

2. MATERIAL

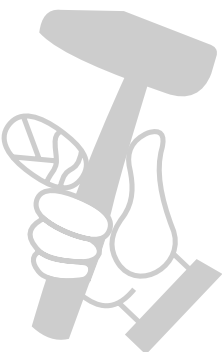

	TECHNICAL DATA SHEET	Reference	FT ROS
		Date	26/02/14
		Revision	2
		Page	2 of 13
Denomination: SELF TAPPING SCREW		Codes	T81, TA281, T81C, TA281C, T82, TA282, T82C, TA282C, T83, AUE, TCPZ, TCPN, TCPA2, TFI

Characteristics	T81, TGU81, T81C, T82, T82C, T83, AUE, TCPZ, TCPN, TFI	TA281, TA281C, TA282, TA282C, TCPA2
Material	Special steel for thermal coating SAE J403 1022	Stainless Steel A2
Outer stiffness	> 500 HV	---
Inner stiffness	240 - 450 HV	---
Superficial thickness	ST 2.5 \bar{r} .5: 0.05 \bar{r} .18 mm. ST 3.9 \bar{r} .5: 0.10 \bar{r} .23 mm. ST 6.3: 0.15 \bar{r} .28 mm.	---

3. TABLA DE SELECCION

Code	Norma	Head	slots	Washer <input type="checkbox"/> EPDM (1)	Coating (2)
T81	DIN 7981	Round	Phillips	---	Zinc Plated
TA281	DIN 7981	Round	Phillips	---	Stainless Steel
T81C	DIN 7981	Round	Robertson	---	Zinc Plated
TA281C	DIN 7981	Round	Robertson	---	Stainless Steel
T82	DIN 7982	Countersunk	Phillips	---	Zinc Plated
TA282	DIN 7982	Countersunk	Phillips	---	Stainless Steel
T82C	DIN 7982	Countersunk	Robertson	---	Zinc Plated
TA282C	DIN 7982	Countersunk	Robertson	---	Stainless Steel
T83	DIN 7983	Oval	Phillips	---	Zinc Plated
AUE	DIN 6928	Hex flange head	---	16, 18, 25	Zinc Plated
TCPZ	---	Extra flat	Phillips	---	Zinc Plated
TCPN	---	Extra flat	Phillips	---	Black Zinc Plated
TCPA2	---	Extra flat	Phillips	---	Stainless Steel
FIMA	---	Extra flat	Torx	---	Zinc Plated

(1) Characteristics EPDM washer according to Technical data sheet ARVUL

(2) Coatings:

Zinc Plated \square 3 μ n according to ISO 4042 A1J

Black Zinc Plated \square 3 μ n according to ISO 4042 A1N

	TECHNICAL DATA SHEET	Reference	FT ROS
		Date	26/02/14
		Revision	2
		Page	3 of 13
Denomination: SELF TAPPING SCREW		Codes	T81, TA281, T81C, TA281C, T82, TA282, T82C, TA282C, T83, AUE, TCPZ, TPCN, TOPA2, TFI

4.- PREVIOUS HOLE

In order to achieve a correct installation using self tapping screws, a previous hole is required. Chosen from the chart below (UNE 17020):

Thread	Steel or brass sheet thickness				Aluminum sheet thickness					
	[mm]	0.4 - 0.6	0.6 - 1.5	1.5 - 2.5	2.5 - 4.0	0.4 - 0.6	0.6 - 1.0	1.0 - 1.5	1.5 - 2.5	2.5 - 4.0
ST 2.9		2.25	2.40	2.50	—	2.20	2.20	2.25	2.40	—
ST 3.5		2.70	2.80	2.90	3.00	2.70	2.70	2.80	2.80	—
ST 3.9		—	3.10	3.20	3.30	—	3.00	3.00	3.10	3.10
ST 4.2		—	3.30	3.40	3.50	—	3.20	3.20	3.30	3.30
ST 4.8		—	3.80	3.90	4.00	—	3.70	3.70	3.80	3.80
ST 5.5		—	4.40	4.50	4.60	—	4.30	4.30	4.40	4.40
ST 6.3		—	5.10	5.20	5.30	—	5.00	5.00	5.10	5.10

Having a too big hole could ruin base materials thread or a non proper fixation.
Having a too small hole could cause the impossibility of turning the screw, break it or twist base material.

5. SCREW CHARACTERISTIC ENDURANCE*

SIZE	TENSION LOAD [kN]	SHEAR LOAD [kN]
ST 3.5	3.91	2.35
ST 3.9	4.29	2.57
ST 4.2	5.31	3.18
ST 4.8	6.66	3.99
ST 5.5	8.87	5.32
ST 6.3	10.69	6.41

1 kN □ 100 Kg

* Characteristic endurance is the one with a probability over 95% of being exceeded. Depending on the results of the test, dispersion of the breaking loads and the number of test performed.

In tension loads it should be considered the sheet metal own endurance; it will be lower than the screw itself because the screw will ruin the sheet metal joint.

TECHNICAL DATA SHEET		Reference	FT ROS
		Date	26/02/14
		Revision	2
		Page	4 of 13
Denomination: SELF TAPPING SCREW		Codes	T81, TA281, T81C, TA281C, T82, TA282, T82C, TA282C, T83, AUE, TCPZ, TPCN, TCPA2, TFL

6. GEOMETRIC DIMENSIONS

6.1.- T81 SCREW (DIN 7981): SELF TAPPING ROUND HEAD , PHILLIPS

Code		ST 2.9	ST 3.5	ST 3.9	ST 4.2	ST 4.8	ST 5.5	ST 6.3
d_k : Head diameter	[mm]	5.45	6.7	7.3	8.0	9.4	10.6	12.3
k : Head Thickness	[mm]	2.2	2.6	2.8	3.05	3.55	3.95	4.55
Phillips slots n		1	2	2	2	2	3	3
R : Head radius	[mm]	4.4	5.4	5.8	6.2	7.2	8.2	9.5
D : thread outer diameter	[mm]	2.90	3.53	3.90	4.22	4.80	5.46	6.25
d : thread inner diameter	[mm]	2.18	2.64	2.92	3.10	3.58	4.17	4.88
p : pitch	[mm]	1.1	1.3	1.3	1.4	1.6	1.8	1.8
y : tip length □	[mm]	2.6	3.2	3.5	3.7	4.3	5	6
l : lengths	[mm]	6 – 25	6 – 38	6 – 50	9 – 90	9 – 140	13 – 120	13 – 120
l_s : max thread length	[mm]	--	--	--	--	90	90	90
Screwdriver bit code (Phillips drive)		PUPHC01 PUPHL01	PUPHC02 PUPHL02	PUPHC02 PUPHL02	PUPHC02 PUPHL02	PUPHC02 PUPHL02	PUPHC03 PUPHL03	PUPHC03 PUPHL03

∑ Zinc Plated (T81 Code) and stainless steel A2 (TA281 Code)

∑ General use and sheet metal-sheet metal. Use stainless steel screws joining aluminum (TA281 Code)



	TECHNICAL DATA SHEET	Reference	FT ROS
		Date	26/02/14
		Revision	2
		Page	5 of 13
Denomination: SELF TAPPING SCREW		Codes	T81, TA281, T81C, TA281C, T82, TA282, T82C, TA282C, T83, AUE, TCPZ, TPCN, TCPA2, TFI

6.2.- T81C SCREW (DIN 7981 ROBERTSON): SELF TAPPING ROUND HEAD, SQUARE slots

Code		ST 3.5	ST 3.9	ST 4.2	ST 4.8
d _k : Head diameter	[mm]	6.7	7.3	8.0	9.4
k: Head Thickness	[mm]	2.6	2.8	3.05	3.55
Robertson slots n/		1	1	2	2
R: Head radius	[mm]	5.4	5.8	6.2	7.2
D: thread outer diameter	[mm]	3.53	3.90	4.22	4.80
d: thread inner diameter	[mm]	2.64	2.92	3.10	3.58
p: pitch	[mm]	1.3	1.3	1.4	1.6
y: tip length □	[mm]	3.2	3.5	3.7	4.3
l: lengths	[mm]	10 – 16	13 – 25	13 – 50	13 – 70
Screwdriver bit code (Robertson drive)		PUCUC01 PUCUL01	PUCUC01 PUCUL01	PUCUC02 PUCUL02	PUCUC02 PUCUL02

- ∑ Zinc Plated (T81C Code) stainless steel A2 (TA281C Code)
- ∑ General purpose sheet metal-sheet metal. Aluminum must use stainless steel screw (TA281C Robertson)

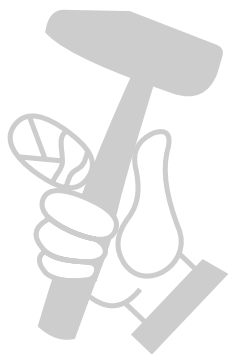



	TECHNICAL DATA SHEET	Reference	FT ROS
		Date	26/02/14
		Revision	2
		Page	6 of 13
Denomination: SELF TAPPING SCREW		Codes	T81, TA281, T81C, TA281C, T82, TA282, T82C, TA282C, T83, AUE, TCPZ, TPCN, TCPA2, TFI

6.3.- T82 SCREW (DIN 7982 PHILLIPS): SELF TAPPING COUNTERSUNK HEAD, PHILLIPS

Code	ST 2.9	ST 3.5	ST 3.9	ST 4.2	ST 4.8	ST 5.5	ST 6.3
d: Head diameter [mm]	5.6	6.9	7.5	8.1	9.1	10.8	12.4
k: Head Thickness [mm]	1.7	2.1	2.3	2.5	3	3.4	3.8
slots Phillips n°	1	2	2	2	2	3	3
Head angle °	80	80	80	80	80	80	80
D: thread outer diameter [mm]	2.90	3.53	3.90	4.22	4.80	5.46	6.25
d: thread inner diameter [mm]	2.18	2.64	2.92	3.10	3.58	4.17	4.88
p: pitch [mm]	1.1	1.3	1.3	1.4	1.6	1.8	1.8
y: tip length ≤ [mm]	2.6	3.2	3.5	3.7	4.3	5	6
l: lengths [mm]	6 – 25	9 – 38	9 – 50	9 – 70	13 – 70	13 – 70	13 – 70
Screwdriver bit code (Phillips drive)	PUPHC01 PUPHL01	PUPHC02 PUPHL02	PUPHC02 PUPHL02	PUPHC02 PUPHL02	PUPHC02 PUPHL02	PUPHC03 PUPHL03	PUPHC03 PUPHL03

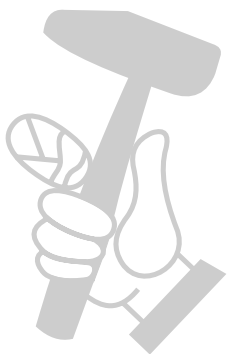
- Zinc Plated (T82 Code) and stainless steel A2 (TA282 Code)
- General purpose sheet metal-sheet metal joints where screw's head must be at the same level than material to fix.



	TECHNICAL DATA SHEET	Reference	FT ROS
		Date	26/02/14
		Revision	2
		Page	7 of 13
Denomination: SELF TAPPING SCREW		Codes	T81, TA281, T81C, TA281C, T82, TA282, T82C, TA282C, T83, AUE, TCPZ, TPCN, TCPA2, TFI

6.4.- T82 SCREW (DIN 7982 ROBERTSON): SELF TAPPING COUNTERSUNK HEAD.

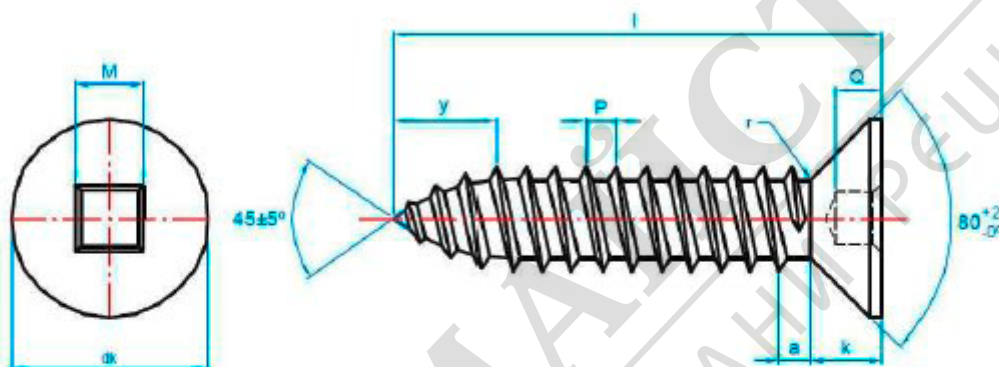

Code		ST 3.9	ST 4.2*	ST 4.8
dk: Head diameter	[mm]	7.5	8.5	9.1
k: Head Thickness	[mm]	2.3	2.5	3
slots Robertson n°		1	2	2
Head angle	°	80	80	80
D: thread outer diameter	[mm]	3.90	4.22	4.80
d: thread inner diameter	[mm]	2.92	3.10	3.58
p: pitch	[mm]	1.3	1.4	1.6
y: tip length ≤	[mm]	3.5	3.7	4.3
l: lengths	[mm]	16 – 32	19 – 50	16 – 60
Screwdriver bit code (Robertson drive)		PUCUC01 PUCUL01	PUCUC02 PUCUL02	PUCUC02 PUCUL02

- Zinc Plated (T82C Code) and stainless steel A2 (TA282C Code)
- General purpose sheet metal-sheet metal joints where screw's head must be at the same level than material to fix.
- ST 4.2 size only available stainless steel version



	TECHNICAL DATA SHEET	Reference	FT ROS
		Date	26/02/14
Denomination: SELF TAPPING SCREW		Revision	2
		Page	8 of 13
		Codes	T81, TA281, T81C, TA281C, T82, TA282, T82C, TA282C, T83, AUE, TCPZ, TPCN, TCPA2, TFI

6.5.- T83 SCREW (DIN 7983): SELF TAPPING OVAL HEAD

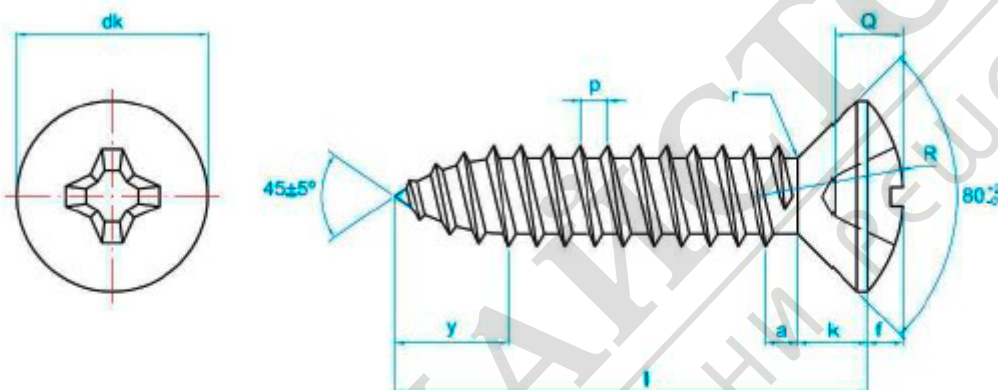

Code	ST 2.9	ST 3.5	ST 3.9	ST 4.2	ST 4.8	ST 5.5	ST 6.3
d_h : Head diameter [mm]	5.5	6.8	7.5	8.1	9.5	10.8	12.4
k: Head Thickness [mm]	1.7	2.1	2.3	2.5	3.	3.4	3.8
slots Phillips n°	1	2	2	2	2	3	3
Head angle °	80	80	80	80	80	80	80
D: thread outer diameter [mm]	2.90	3.53	3.90	4.22	4.80	5.46	6.25
d: thread inner diameter [mm]	2.18	2.64	2.92	3.10	3.58	4.17	4.88
p: pitch [mm]	1.1	1.3	1.3	1.4	1.6	1.8	1.8
y: tip length ≤ [mm]	2.6	3.2	3.5	3.7	4.3	5	6
l: lengths [mm]	6 – 25	9 – 38	9 – 50	9 – 70	13 – 70	13 – 70	13 – 70
Screwdriver bit code (Phillips drive)	PUPHC01 PUPHL01	PUPHC02 PUPHL02	PUPHC02 PUPHL02	PUPHC02 PUPHL02	PUPHC02 PUPHL02	PUPHC03 PUPHL03	PUPHC03 PUPHL03

- Zinc Plated (T83 Code)
- General purpose sheet metal-sheet metal joints where screw's head must be at the same level than material to fix, but a higher endurance in the slot is required (better transmission of torque wrench)

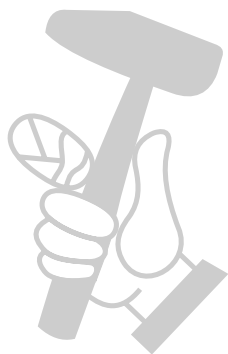

	TECHNICAL DATA SHEET	Reference	FT ROS
		Date	26/02/14
		Revision	2
		Page	9 of 13
Denomination: SELF TAPPING SCREW		Codes	T81, TA281, T81C, TA281C, T82, TA282, T82C, TA282C, T83, AUE, TCPZ, TPCN, TCPA2, TFI

6.6.- AUE SCREW : SELF TAPPING HEXAGON WASHER HEAD

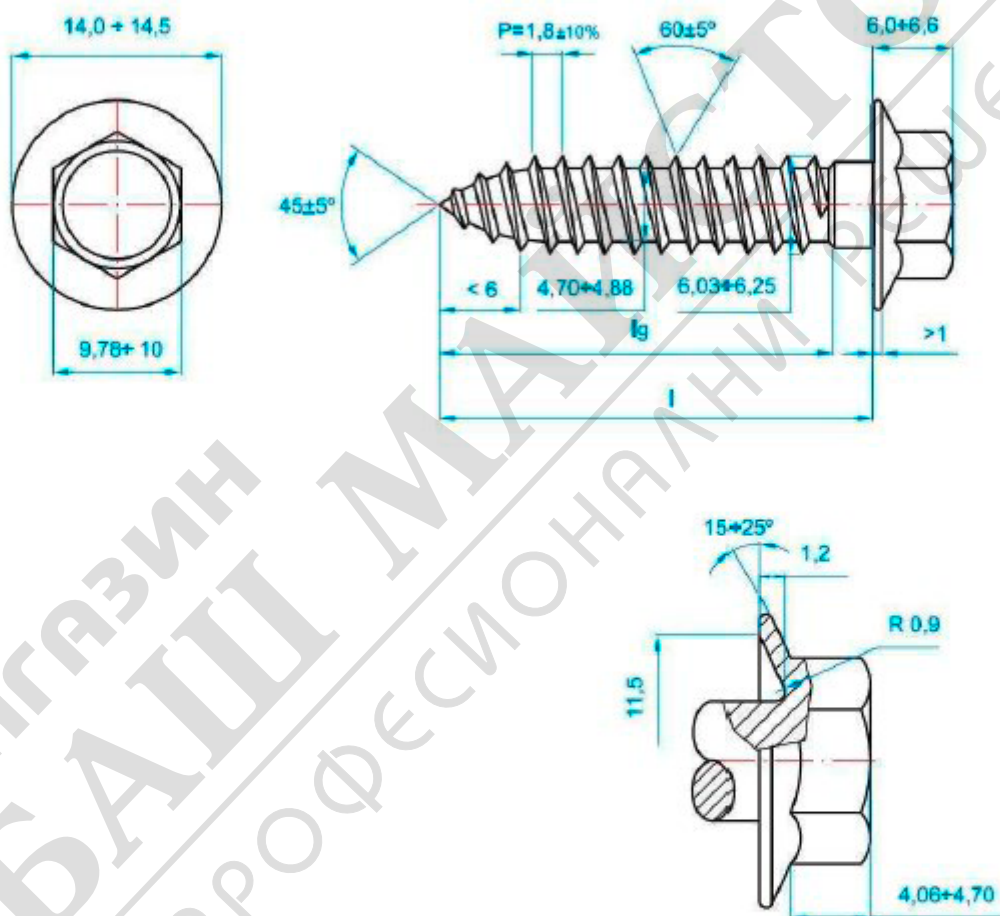

Code	ST 6.3
d_c : Head washer diameter	[mm] 14
k : Head Thickness	[mm] 6
Open end wrench	10
D : thread outer diameter	[mm] 6.25
d : thread inner diameter	[mm] 4.88
p : pitch	[mm] 1.8
l : lengths	[mm] 19 – 150
l_g : max thread length	[mm] 80
Power dopbit magnetic hexagon head code	 BOCA010

	TECHNICAL DATA SHEET	Reference	FT ROS
		Date	26/02/14
		Revision	2
		Page	10 of 13
Denomination: SELF TAPPING SCREW		Codes	T81, TA281, T81C, TA281C, T82, TA282, T82C, TA282C, T83, AUE, TCPZ, TPCN, TCPA2, TFI

- Zinc Plated (Code AUE)
- Similar geometry DIN 6928, with reinforced washer:
 - Better torque wrench
 - Better distribution of compressive stress over base material.
 - Better opposition to ruin the thread.
 - Suitable with soft base materials with big holes or where a big torque wrench is required.
- General purpose sheet metal-sheet metal joints where very high loads are applied.
- Zinc coated version washer-EPDM $\varnothing 16$ mounted to create a water tightness seal in fronts and roofs (ask technical data sheet ARVUL)

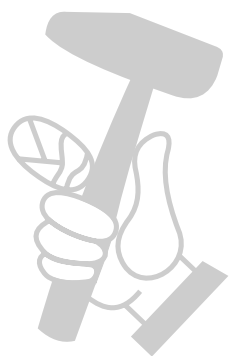

	TECHNICAL DATA SHEET	Reference	FT ROS
		Date	26/02/14
		Revision	2
		Page	11 of 13
Denomination: SELF TAPPING SCREW		Codes	T81, TA281, T81C, TA281C, T82, TA282, T82C, TA282C, T83, AUE, TCPZ, TCPN, TCPA2, TFI

6.7.- TCP / TCPA2 SCREW: SELF TAPPING, EXTRA FLAT HEAD, PHILLIPS

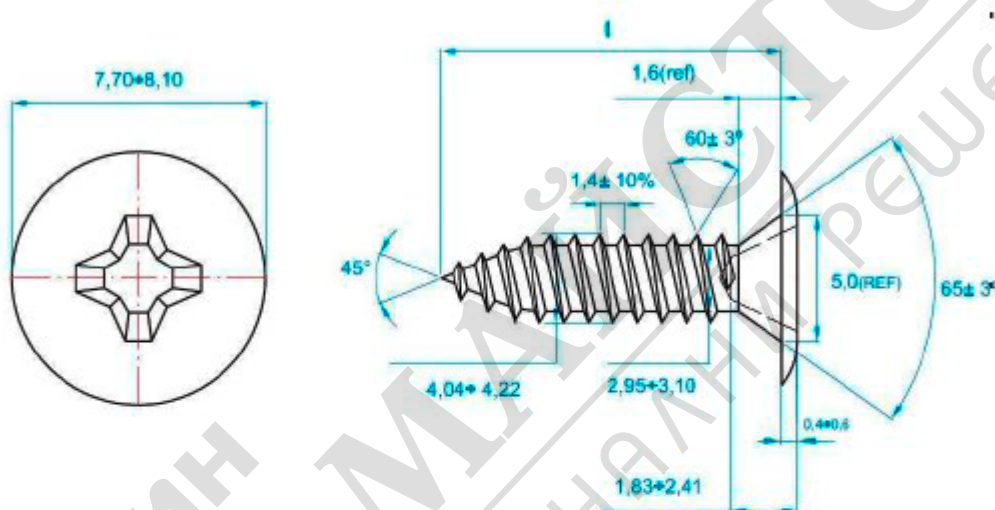

Code	ST 4.2
d_h : Head diameter \leq	[mm] 8.0
k : Head Thickness	[mm] 0.5
slots Phillips n°	2
D : thread outer diameter \leq	[mm] 4.22
d : thread inner diameter \leq	[mm] 3.10
p : pitch	[mm] 1.4
l : lengths	[mm] 13 – 32
Countersunk head angle	° 65
Screwdriver bit code (Phillips drive)	PUPHC02 PUPHL02

- Zinc Plated (TCPZ Code), Black Zinc Plated (TCPN Code) and fully painted in white RAL 9010 (TCPB Code).
- Version in stainless steel class A2 (TCPA2 Code).
- Bevelled head to avoid collisions with mobile parts.
- Use in unions over metal where a head low profile is required (sliding windows, etc.)
- Could substitute blind rivets in many applications with the advantage that this could be disassembled.
- Reduced cone below the head to improve placement over flat surfaces.

	TECHNICAL DATA SHEET	Reference	FT ROS
		Date	26/02/14
		Revision	2
		Page	12 of 13
Denomination: SELF TAPPING SCREW		Codes	T81, TA281, T81C, TA281C, T82, TA282, T82C, TA282C, T83, AUE, TCPZ, TPCN, TCPA2, TFI

6.8.- FIMA SCREW: SELF TAPPING CILINDRICAL HEAD, EXTRA FLAT

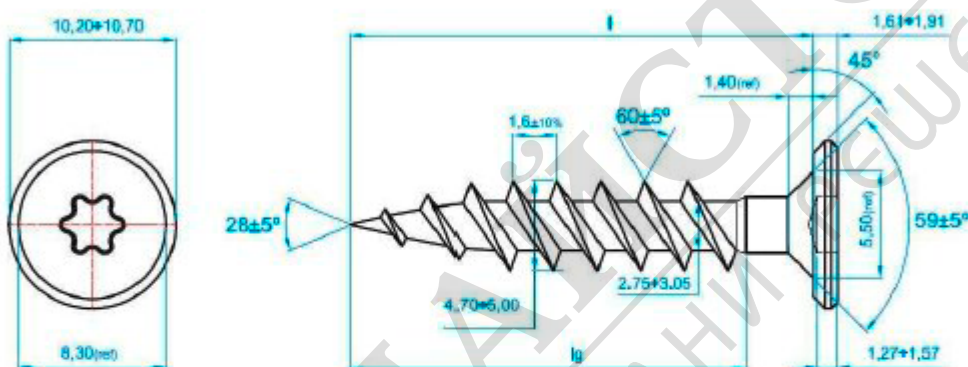

Code	ST 4.8
d_c : Head diameter	[mm] 10.50
k : Head Thickness	[mm] 1.76
slots (Torx) n°	20
Drill length	[mm] 4
D : thread outer diameter \leq	[mm] 4.80
d : thread inner diameter \leq	[mm] 3.05
p : pitch	[mm] 1.6
l : lengths	[mm] 25 -- 90
Countersunk head angle	° 59
Screwdriver bit code (Torx drive)	PUT0020

- Zinc Plated (TFI Code)
- Double thread
- Fixation of aluminum frames over any base material.
- Extra flat head avoids countersunk and ensures a bigger joint surface over the frame.
- All purpose fillet over wood, nylon and metals.

	TECHNICAL DATA SHEET	Reference	FT ROS
		Date	26/02/14
		Revision	2
		Page	13 of 13
Denomination: SELF TAPPING SCREW		Codes	T81, TA281, T81C, TA281C, T82, TA282, T82C, TA282C, T83, AUE, TCPZ, TPCN, TCPA2, TFI

7.- COLORS

Every self tapping screw can be painted with these options:

7.1.- Only head or head plus EPDM washer

- White 9010
- Pyrenees white 9002
- Oyster white 9018
- Bidasoa Crème 1000
- Sand 1001
- Ivory 1015
- Copper 1007
- Tile Red 3011
- Coral red 3003
- Burdeaux red 3005
- Blue 5009
- Lake blue 5019
- Navarra green 6028
- Light green 6021
- Moss green 6005
- Metal grey 9006
- Grey 7035
- Black 9005



Lengths: 13 – 90 mm. Diameter: 3.9 – 6.3 mm. Min. amount: 4000 units
Ask commercial dept. price and delivery.

7.2.- Whole painted

- White 9010
- Black 9005
- Burdeaux red 3005
- Moss green 6005
- Blue 5009



Length: 6.5 - 32 mm. Diameter: 2.9 – 5.5 mm. Min. amount: 15 kg
Ask commercial dept. price and delivery.

7.3.- Ornamental PVC cups for AUE screws (ATAP code)

- Pyrenees white 9002
- Blanco oyster 9018
- Bidasoa Crème 1000
- Sand 1001
- Tile red 3011
- Coral red 3003
- Lake blue 5019
- Navarra green 6028
- Light green 6021

