

Parts list

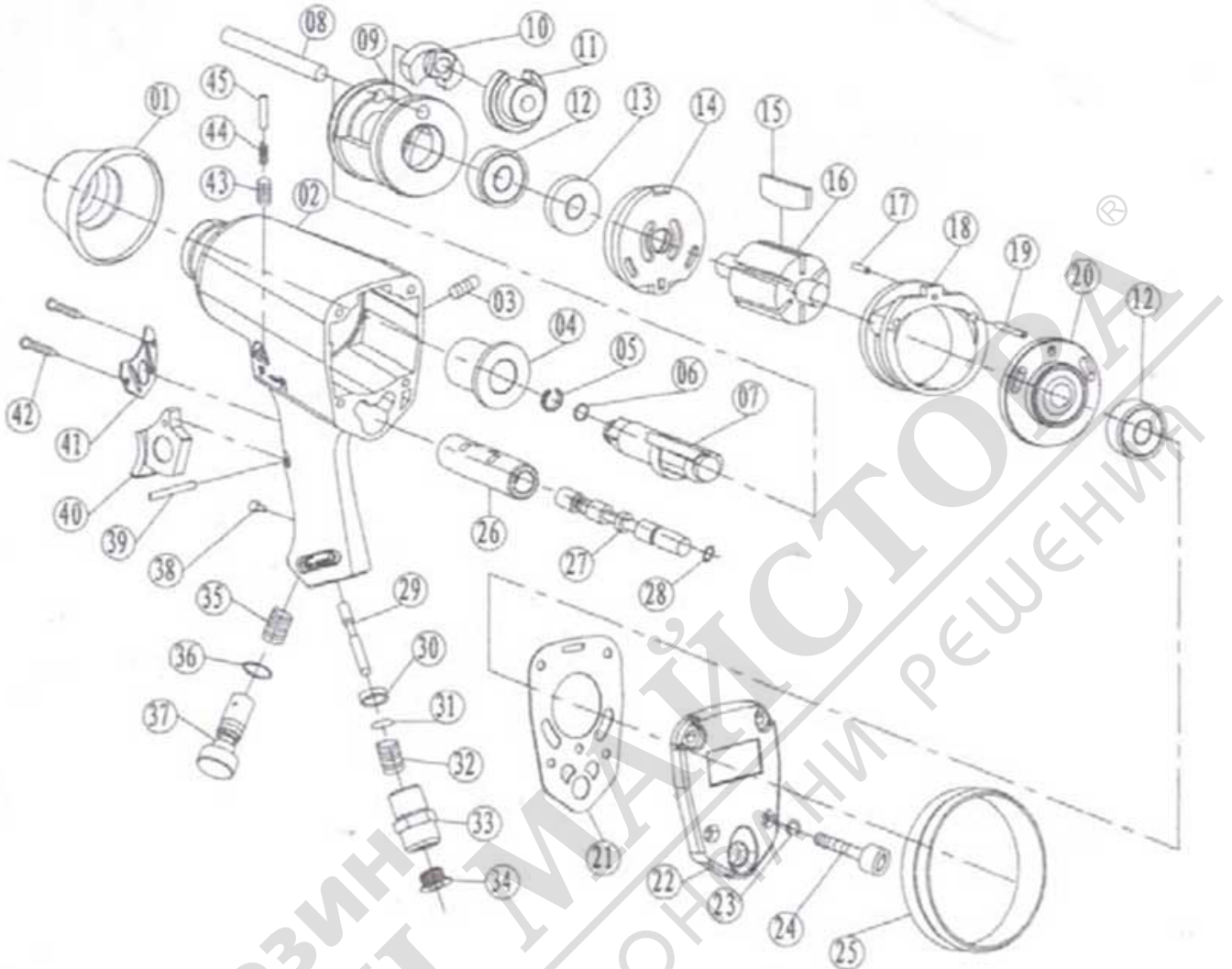

No.	Description	NO	Description	No.	Description	No.	Description
1	Protecting Rubber	13	Oil seal	25	Protecting Rubber	37	Air Regulator
2	Housing	14	Front End plate	26	Valve Sleeve	38	Bolt
3	Bolt	15	Rotor blade	27	Reverse Valve	39	Pin
4	Anvil Bushing	16	Rotor	28	O-ring	40	Trigger
5	Anvil Collar	17	Pin	29	Valve Stem	41	Exhaust cover
6	O-ring	18	Cylinder	30	Washer	42	Bolt
7	Anvil	19	Bolt	31	Steel ball	43	Screw
8	Hammer Pin	20	Rear End Plate	32	Inlet Spring	44	Spring
9	Hammer Cage	21	Gasket	33	Air Inlet Plug	45	Pin
10	Hammer Dog	22	Rear Cover	34	Dust Free Cover		
11	Drive Cam	23	Washer	35	Spring		
12	Ball Bearing	24	Bolt	36	O-ring		