

HONDA

GX22 – GX31

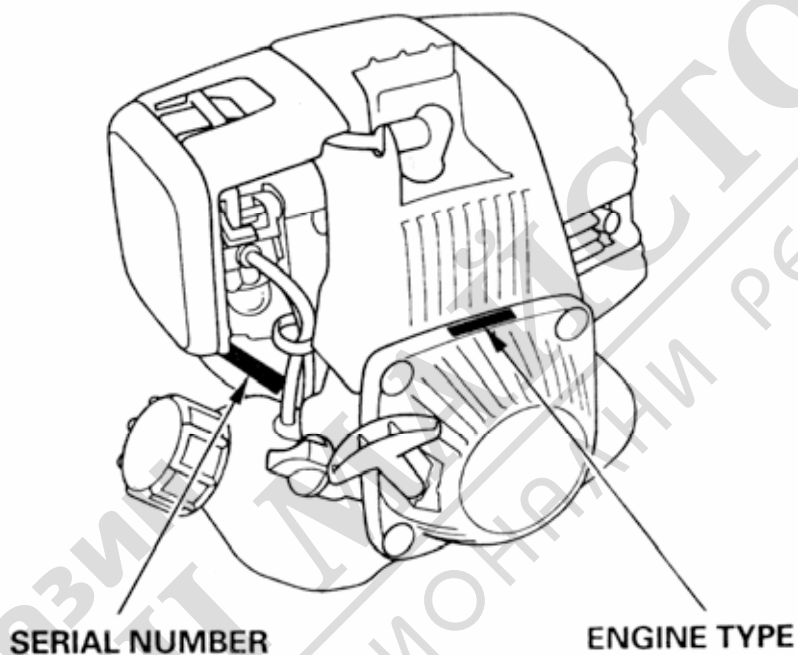

OWNER'S MANUAL



32ZM3600
00X32-ZM3-6000

© HONDA MOTOR CO LTD 1997
O HG 50009704

INTRODUCTION

Thank you for purchasing a Honda engine.

This manual covers the operation and maintenance of your engine: GX22 - GX31

All information in this publication is based on the latest product information available at the time of printing.

Honda Motor Co. Ltd. reserves the right to make changes at any time without notice and without incurring any obligation.

No part of this publication may be reproduced without written permission.

This manual should be considered a permanent part of the engine and should remain with it if it is resold.

Pay special attention to statements preceded by the following words:

! WARNING

Indicates a strong possibility of severe personal injury or death if instructions are not followed.

CAUTION

Indicates a possibility of personal injury or equipment damage if instructions are not followed.

NOTICE

Indicates that equipment or property damage can result if instructions are not followed.

NOTE: Gives helpful information.

If a problem should arise, or if you have any questions about your engine consult an authorised Honda dealer.

! WARNING

The Honda engine is designed to give safe and dependable service if operated according to instructions. Read and understand the Owner's Manual before operating the engine. Failure to do so could result in personal injury or equipment damage.

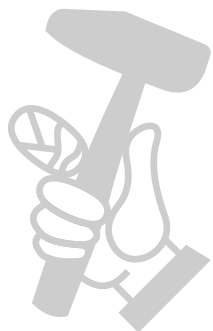

SAFETY INSTRUCTIONS

! WARNING

To ensure safe operation



The Honda engine is designed to give safe and dependable service if operated according to instructions. Read and understand the Owner's Manual before operating the engine. Failure to do so could result in personal injury or equipment damage.

- Do not start the engine without mounting it on an equipment. It is designed to give safe and dependable service only when it is mounted on an equipment. Before operating the engine, read and understand the Owner's Manual furnished with the equipment along with this Owner's Manual.
- Always make a pre-operation inspection (page 3) before you start the engine. You may prevent an accident or equipment damage.
- To prevent fire hazards and to provide adequate ventilation, keep the engine at least 1 metre (3 feet) away from buildings and other equipment during operation. Do not place flammable objects close to the engine.
- Children and pets must be kept away from the area of operation due to a possibility of burns from hot engine components or injury from any equipment the engine may be used to operate.
- Know how to stop the engine quickly and understand the operation of all controls. Never permit anyone to operate the engine without proper instructions.
- Do not place flammable objects such as gasoline, matches, etc. close to the engine while it is running.
- Refuel in a well-ventilated area with the engine stopped. Gasoline is highly flammable and explosive under certain conditions.
- Do not overfill the fuel tank. There should be no fuel in the filler neck.
- Make sure that the filler cap is closed securely.
- If any fuel is spilled, clean it up completely and allow petroleum vapours to dissipate before starting the engine.
- Do not smoke or allow flames or sparks where the engine is refuelled or where gasoline is stored.
- Exhaust gas contains poisonous carbon monoxide. Avoid inhalation of exhaust gases. Never run the engine in a closed garage or confined area.
- Do not place anything on the engine, as it may create a fire hazard.
- A spark arrestor is fitted to this engine.
- The muffler becomes very hot during operation and remains hot for a while after stopping the engine. Be careful not to touch the muffler while it is hot. To avoid severe burns or fire hazards, let the engine cool before transporting it or storing it indoors.

SAFETY INSTRUCTION LOCATION

This instruction warns you of potential hazards that can cause serious injury. Read it carefully.

READ OWNER'S MANUAL BEFORE OPERATION.

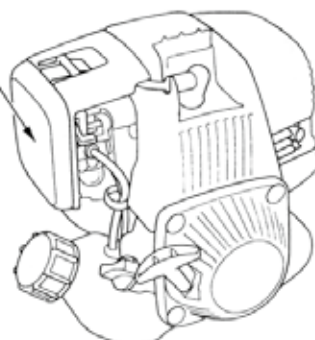

PRE-OPERATION CHECK

1. Engine oil level

CAUTION:

- Running the engine with insufficient oil can cause serious engine damage.
- Be sure to check the engine on a level surface with the engine stopped.

1. Place the engine horizontally on a level surface.
2. Remove the oil filler cap and check the oil level: it should reach the top of the oil filler neck.
3. If the level is low, fill to the top of the oil filler neck with the recommended oil.

Every 10 hours, check the engine oil level and replenish oil up to the top of the oil filler neck if the engine is operated for more than 10 hours continuously.

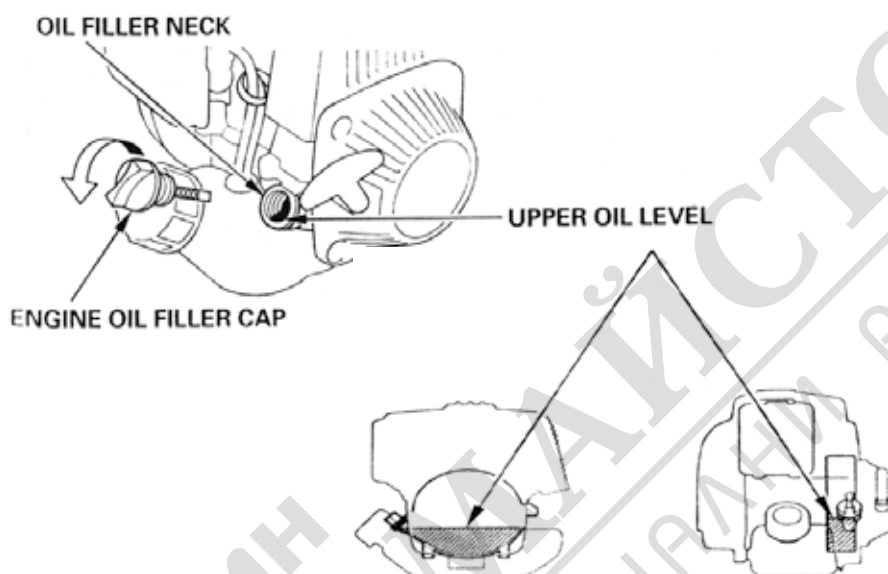

Use Honda 4-stroke, or an equivalent high detergent, premium quality motor oil certified to meet or exceed U.S. automobile manufacturer's requirements for service classification SG, SF. Motor oils classified SG, SF will show this designation on the container. SAE 10W-30 is recommended for general, all temperature use.

**MULTI
VISCOSITY**

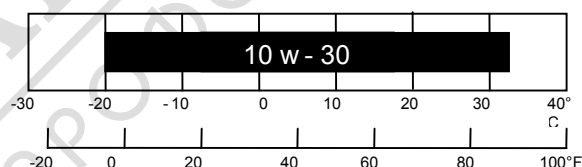

Ambient temperature

CAUTION:

Using non-detergent oil or 2-stroke engine oil could shorten the engine's service life.

2. Air cleaner

CAUTION:

Never run the engine without the air cleaner. Rapid engine wear will result.

Check cleaner for dirt or obstruction of element (page 10)

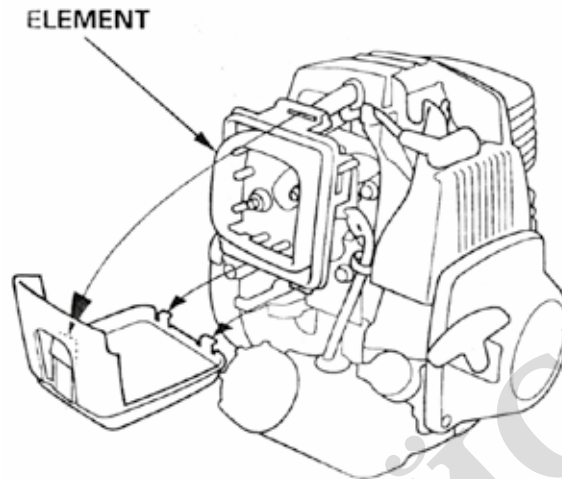

3. Fuel

Use automotive gasoline (Unleaded or low leaded is preferred to minimise combustion chamber deposits).

FOR NEW SOUTH WALES ONLY:

Use unleaded fuel only.

Never use an oil/gasoline mixture or dirty gasoline. Avoid getting dirt dust or water in the fuel tank.

! WARNING

- Gasoline is extremely flammable and is explosive under certain conditions
- Refuel in a well-ventilated area with the engine stopped. Do not smoke or allow flames or sparks in the area where the engine is refuelled or where gasoline is stored.
- Do not overfill the fuel tank (there should be no fuel in the filler neck). After refuelling, make sure the tank cap is closed properly and securely.
- Be careful not to spill fuel when refuelling. Spilled fuel or fuel vapour may ignite. If any fuel is spilled, make sure the area is dry before starting the engine.
- Avoid repeated or prolonged contact with skin or breathing of vapour.

KEEP OUT OF REACH OF CHILDREN.

Fuel tank capacity:

GX22: 0.45 ℓ (0.119 US gal .099 Imp gal)

GX31: 0.65 ℓ (0.172 US gal .143 Imp gal)

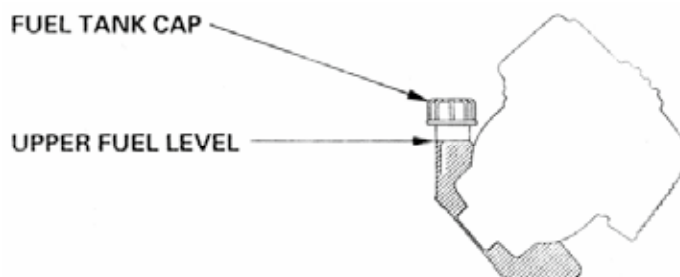

GASOLINES CONTAINING ALCOHOL

If you decide to use a gasoline containing alcohol (gasohol), be sure its octane rating is at least as high as that recommended by Honda. There are two types of "gasohol": one containing ethanol, and the other containing methanol. Do not use gasohol that contains more than 10% ethanol. Do not use gasoline containing methanol (methyl or wood alcohol) that does not also contain cosolvents and corrosion inhibitors for methanol. Never use gasoline containing more than 5% methanol, even if it has cosolvents and corrosion inhibitors.

NOTE:

Fuel system damage or engine performance problems resulting from the use of fuels that contain alcohol is not covered under the warranty. Honda cannot endorse the use of fuels containing methanol since evidence of their suitability is as yet incomplete.

Before buying fuel from an unfamiliar station, try to find out if the fuel contains alcohol, if it does, confirm the type and percentage of alcohol used. If you notice any undesirable operating symptoms while using a gasoline that contains alcohol, or one that you think contains alcohol, switch to a gasoline that you know does not contain alcohol.

4. Re-tightening bolts and nuts

Check for loose bolts and nuts. Tighten the bolts and nuts properly and securely, if necessary.

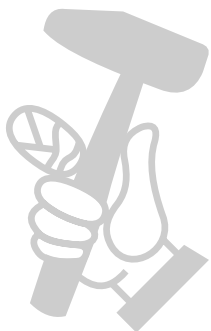

STARTING THE ENGINE

1. Turn the engine switch to the ON position (on the equipment side).
2. Move the choke lever to the CLOSE position.

NOTE:

Do not use the choke if the engine is warm or the air temperature is high.

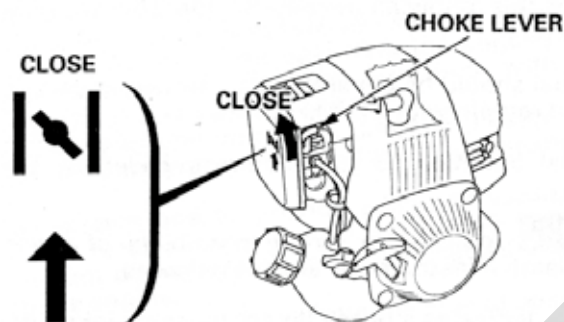

3. Press the priming pump several times until a fuel flow in the fuel return tube is visually noticed.

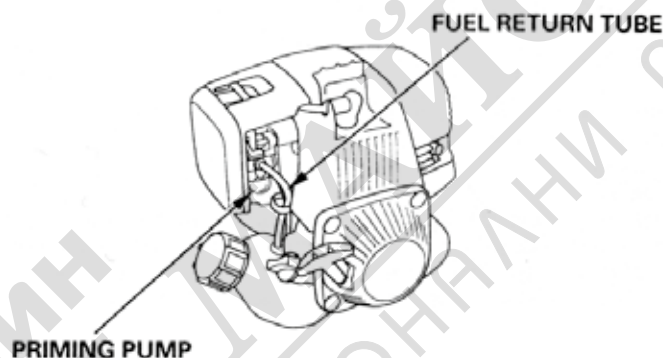

4. Pull the starter grip lightly until resistance is felt, then pull briskly.

CAUTION:

Do not allow the starter grip to snap back against the engine. Return it gently to prevent damage to the starter.

NOTE:

Always pull the starter grip briskly. If not pulled briskly, sparks may fail to jump across the spark plug electrodes, resulting in failure to start the engine.

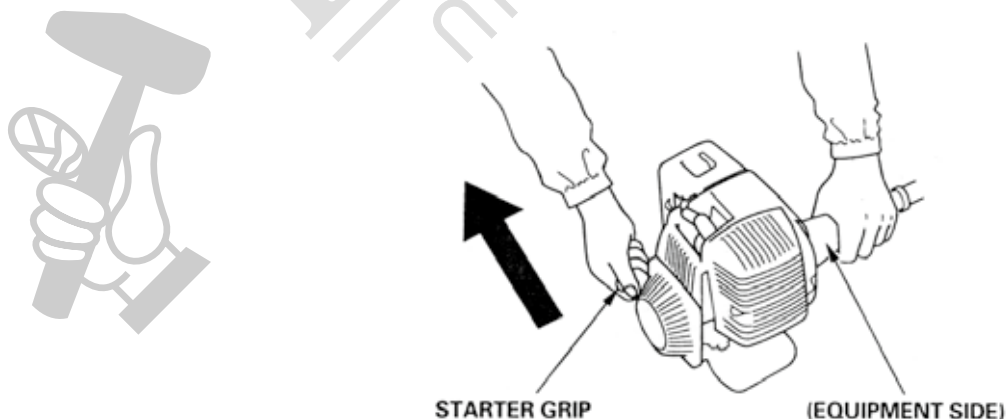

High altitude operation

At high altitude, the standard carburettor air-fuel mixture will be excessively rich. Performance will decrease and fuel consumption will increase.

High altitude performance can be improved by installing a smaller diameter main fuel jet in the carburettor and readjusting the idle needle screw and the idle adjust screw. If you always operate the engine at altitudes higher than 1830m (6,000 feet) above sea level, have your authorised Honda dealer perform these carburettor modifications.

Even with suitable carburettor jetting, engine horsepower will decrease approximately 3.5% for each 305 m (1,000 feet) increase in altitude. The effect of altitude on horsepower will be greater than this if no carburettor modification is made.

CAUTION:

Operation of the engine at an altitude lower than the carburettor is jetted for may result in reduced performance, overheating, and serious engine damage caused by an excessively lean air/fuel mixture.

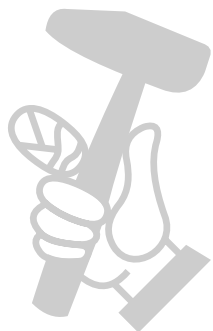

МАГАЗИН
БАШ МАЙСТОР
ПРОФЕСИОНАЛНИ РЕШЕНИЯ

OPERATION

1. Gradually move the choke lever to the OPEN position. Warm up the engine until it run smoothly.

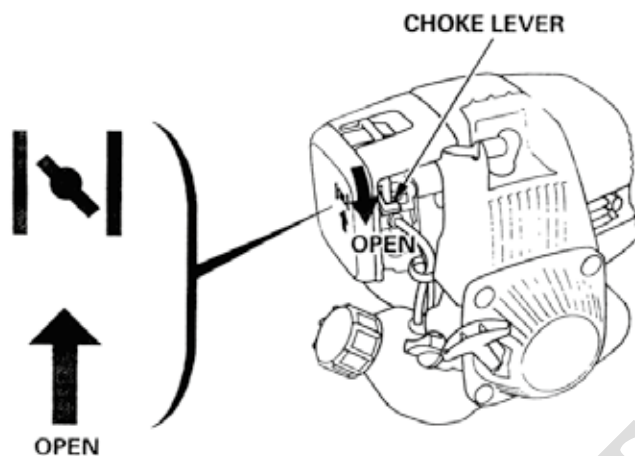

2. Position the throttle control lever for the desired engine speed (on the equipment side).

STOPPING THE ENGINE

To stop the engine in an emergency, turn the engine switch to the OFF position (on the equipment side). Under normal conditions, use the following procedure:

1. Position the throttle control lever fully to LOW (on the equipment side).
2. Turn the engine switch to the OFF position (on the equipment side).



MAINTENANCE

! WARNING

- Shut off the engine before performing any maintenance.
- To prevent accidental start-up, turn OFF the engine switch and disconnect the spark plug cap.
- The engine should be serviced by an authorised Honda dealer unless the owner has proper tools and service data and feels he is mechanically qualified.

CAUTION:

Use only genuine HONDA parts or their equivalent. The use of replacement parts which are not of equivalent quality may damage the engine.

Periodic inspection and adjustment of the Honda engine is essential if high level performance is to be maintained. Regular maintenance will also ensure a long service life. The required service intervals and the kind of maintenance to be performed are described on the table below.

Maintenance Schedule

REGULAR SERVICE PERIOD Performed every indicated month or operating hour interval, whichever comes first		Each use	First month or 10 Hrs	Every 3 month or 25 Hrs	Every 6 month or 50 Hrs	Every year or 100 Hrs
ITEM						
Engine Oil	Check	3				
	Change		3		3	
Air Cleaner	Check	3				
	Clean			3 (1)		
All bolts & nuts (Re-tighten if necessary)	Check	3				
Engine cooling fins	Check				3	
Spark plug	Clean - adjust				3	
Valve clearance	Adjust				3 (2)	
Clutch shoes	Check				3 (2)	
Fuel tank strainer	Check					3
Fuel tank	Clean					3
Fuel line (Replace if necessary)	Check		Every 2 years (2)			

NOTE:

- (1) Service more frequently when used in dusty areas.
- (2) These items should be serviced by an authorised Honda dealer, unless the owner has the proper tools and is mechanically proficient. See the Honda Shop Manual.



1 Oil Change

Drain the oil while the engine is still warm to assure rapid and complete draining.

1. Check the fuel filler cap is tightened.
2. Remove the oil filler cap and drain the oil into the oil container by inclining the engine toward the oil filler neck.
3. Refill with the recommended oil (see page 3) and check the oil level (see page 3).
4. Install the oil filler cap.

ENGINE OIL CAPACITY: 0.10 litres (0.11 US qt, 0.09 Imp qt)

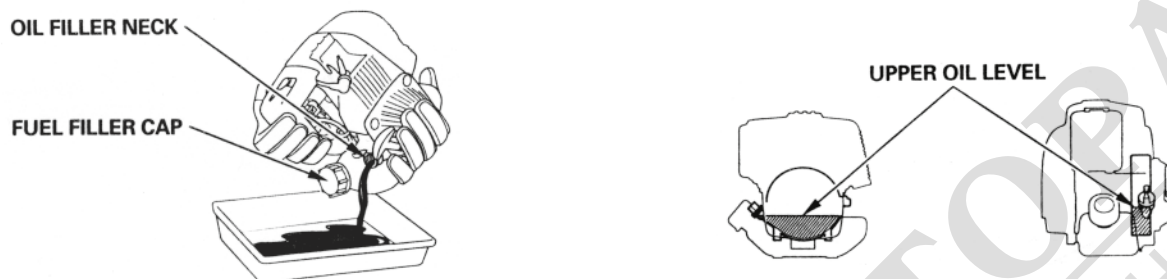

Wash your hands with soap and water after handling used oil.

NOTE:

Please dispose of used motor oil in a manner that is compatible with the environment. We suggest you take it in a sealed container to your local service station for reclamation. Do not throw it in the trash or pour it on the ground.

2 Air cleaner service

A dirty air cleaner will restrict air flow to the carburettor. To prevent carburettor malfunction, service the air cleaner regularly. Service more frequently when operating the engine in extremely dusty areas.

! WARNING

Never use gasoline or low flash point solvents for cleaning the air cleaner element. A fire or explosion could result.

CAUTION:

Never run the engine without the air cleaner. Rapid engine wear will result.

1. Move the choke lever to the CLOSED (upwards) position.
2. Remove the air cleaner cover by unhooking the upper tab on the top of the air cleaner cover and its two lower tabs.
3. Wash the element in a non-flammable or high flash point solvent and dry it thoroughly.
4. Soak the element in clean engine oil and squeeze out the excess oil.
5. Reinstall the air cleaner element.
6. Reinstall the air cleaner cover by inserting the lower tabs, then insert the upper tab.

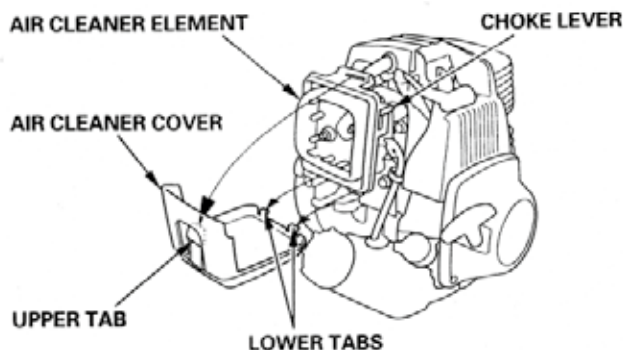

3 Spark plug service

Recommended spark plug:

C5HSB, CR5HSB (NGK)
U16FS-UB, U16FSR-UB (DENSO)

CAUTION:

Never use a spark plug of incorrect heat range.

To ensure proper engine operation, the spark plug must be properly gapped and free of deposits.

1. Remove the spark plug cap and use the proper Size spark plug wrench to remove the spark plug.

! WARNING

If the engine has been running, the muffler will be very hot. Be careful not to touch the muffler.

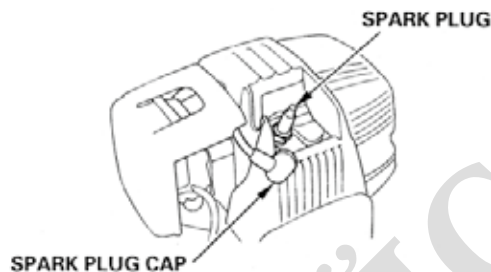

2. Visually inspect the spark plug. Discard the spark plug if there is apparent wear, or if the insulator is cracked or chipped. Clean the spark plug with a wire brush if it is to be reused.
3. Measure the plug gap with a feeler gauge. Correct as necessary by bending the side electrode.
The gap should be:
0.60 - 0.70mm (0.024-0.028in)

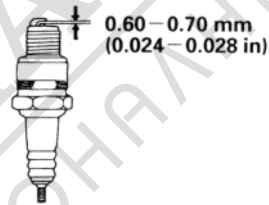

4. Check that the spark plug washer is in good condition and thread the spark plug in by hand to prevent cross-threading.
5. After the spark plug is seated, tighten with a spark plug wrench to compress the washer.

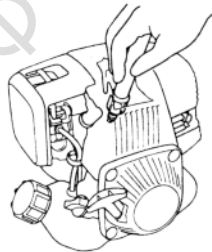

NOTE:

When installing a new spark plug, tighten 1/2 turn after the spark plug seats to compress the washer.
When reinstalling a used spark plug, tighten 1/8 -1/4 turn after the spark plug seats to compress the washer.

CAUTION:

The spark plug must be securely tightened. An improperly tightened spark plug can become very hot and may damage the engine.

4 Fuel filter service

! WARNING

Gasoline is extremely flammable and is explosive under certain conditions Do not smoke or allow flames or sparks in the area.

1. Check the engine oil filler cap is tightened securely.
2. Remove the fuel filler cap and drain the fuel into the container by inclining the engine toward the fuel filler neck.

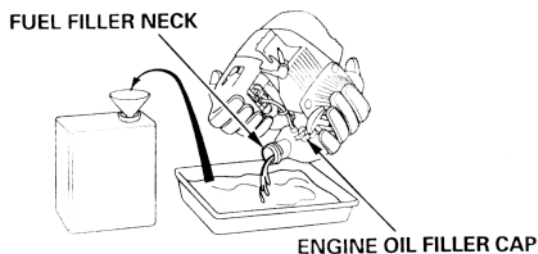

3. Pull out the fuel filter with the mechanic's wire from the fuel filler neck gently.
4. Check the fuel filter of its dirt. If the fuel filter is dirty, wash it gently with non-flammable or high flash point solvent. If the fuel filter is excessively dirty, replace it.

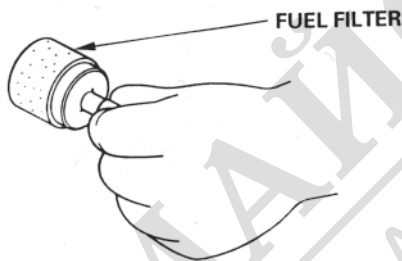

5. Return the fuel filter into the fuel tank and tighten the fuel filter cap securely.

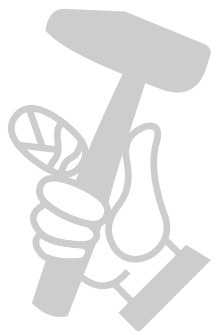

5 Fuel tank cleaning

! WARNING

Gasoline is extremely flammable and is explosive under certain conditions Do not smoke or allow flames or sparks in the area.

1. Check the engine oil filler cap is tightened securely.
2. Remove the fuel filler cap and drain the fuel into the container by inclining the engine toward the fuel filler neck.



3. Pull out the fuel filter with the mechanic's wire from the fuel filler neck gently.
4. Remove water and dirt stood in the fuel tank by rinsing the inside of the fuel tank with non-flammable or high flash point solvent.

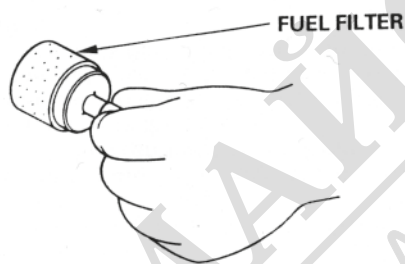

5. Return the fuel filter into the fuel tank and tighten the fuel filter cap securely.

6 Cooling fin service

Inspect the Cooling fin visually through the cover. If there are dry grass, leaves and mud clogged, contact the Honda power equipment dealer for cleaning it.

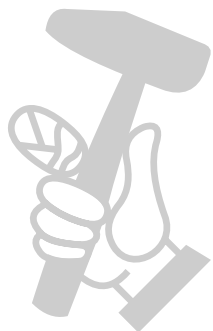
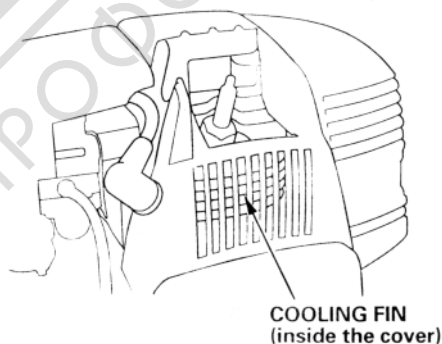

TRANSPORTING/STORAGE

! WARNING

When transporting the engine, tighten the fuel filler cap to prevent fuel spillage. Fuel vapour or spilled fuel may ignite.

Before storing the unit for an extended period;

1. Be sure the storage area is free of excessive humidity and dust.
2. Drain the fuel.

! WARNING

Gasoline is extremely flammable and is explosive under certain conditions Do not smoke or allow flames or sparks in the area.

- a) Check the engine oil filler cap is tightened securely.
- b) Remove the fuel filler cap and drain the fuel into tile container by inclining the engine toward the fuel filler neck.

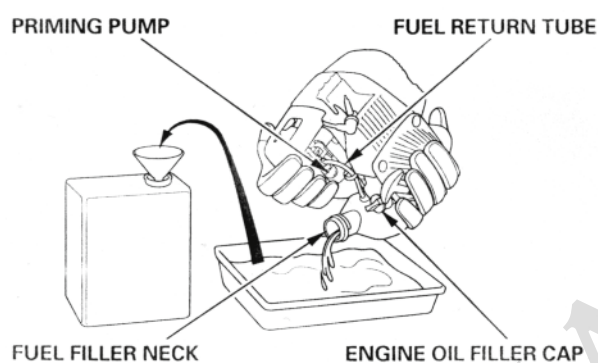

- c) Press the priming pump several times until all fuel left in the fuel return tube is returned into the fuel tank.
 - d) Tilt the engine toward the fuel filler neck again to drain the fuel left in the fuel tank into the Container.
 - e) Tighten the fuel filler cap securely after draining the fuel completely.
3. Change the engine oil (page 10).
 4. Clean the air cleaner (page 10).
 5. Remove the spark plug and pour about a tablespoon of clean engine oil into the cylinder.
 6. Crank the engine several revolutions to distribute the oil, then reinstall the spark plug. Pull the starter rope slowly until resistance is felt.
 7. Cover the engine to keep out dust.

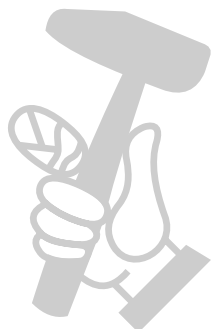

TROUBLESHOOTING

When the engine will not start:

1. Is the engine switch in the ON position (on the equipment side)?
2. Is there fuel in the fuel tank?
3. Is gasoline reaching the carburettor?
To check, press the priming pump several times.
4. Is there a spark at the spark plug?
 - a) Remove the spark plug cap. Clean any dirt from around the spark plug base, then remove the spark plug.
 - b) Install the spark plug in the plug Cap.
 - c) Turn the engine switch ON (on the equipment side).
 - d) Grounding the side electrode to the cooling fin below the spark plug hole, pull the recoil starter to see if sparks jump across the gap.

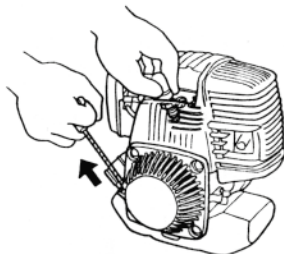

- e) If there is no spark, replace the plug.

If OK, reinstall the spark plug and try to start the engine again according to the instructions.

5. If the engine still does not start, take the engine to an authorised Honda dealer.

SPECIFICATIONS

Dimensions	GX22	GX31
Power equipment description code	GCAF	GCAG
Length	210 mm (8.3 in)	
Width	251 mm (9.9 in)	
Height	249 mm (9.8in)	250 mm (9.8in)
Dry weight	3.4kg (7.3lbs)	3.3kg 7.5lbs)

Engine

Engine type	4-stroke, over head valve, 1 cylinder	
Displacement	22 cm ³ (1.3 cu-in)	31 cm ³ (1.9 cu-in)
Bore x Stroke	33 x 26mm(1.3 x 1.0in)	39 x 26mm(1.5 x 1.0in)
Max. output	0.74kW (1.0 PS)/ 7,000 rpm	1.10kW (1.5 PS)/ 7,000 rpm
Max. torque	1.09 Nm (0.11 kgf-m)/ 4500rpm	1.64 Nm (0.17 kgf-m)/ 4500rpm
Fuel Consumption	340 g/kWh (250 g/PSh)	
Cooling system	Forced air	
Ignition system	Transistor magneto	
PTO shaft rotation	Counterclockwise	

NOTE:

Specifications may vary according to the types, and are subject to change without notice.