



# Makita Werkzeug Ges.m.b.H.

Kolpingstrasse 13, 1230 Wien

Tel: 01 / 616 27 30 - 0\*

Fax: 01 / 616 27 30 - 40

Mail: [verkauf@makita.at](mailto:verkauf@makita.at)

Web: [www.makita.at](http://www.makita.at)

## Makita Service Information / Model: DA3010F

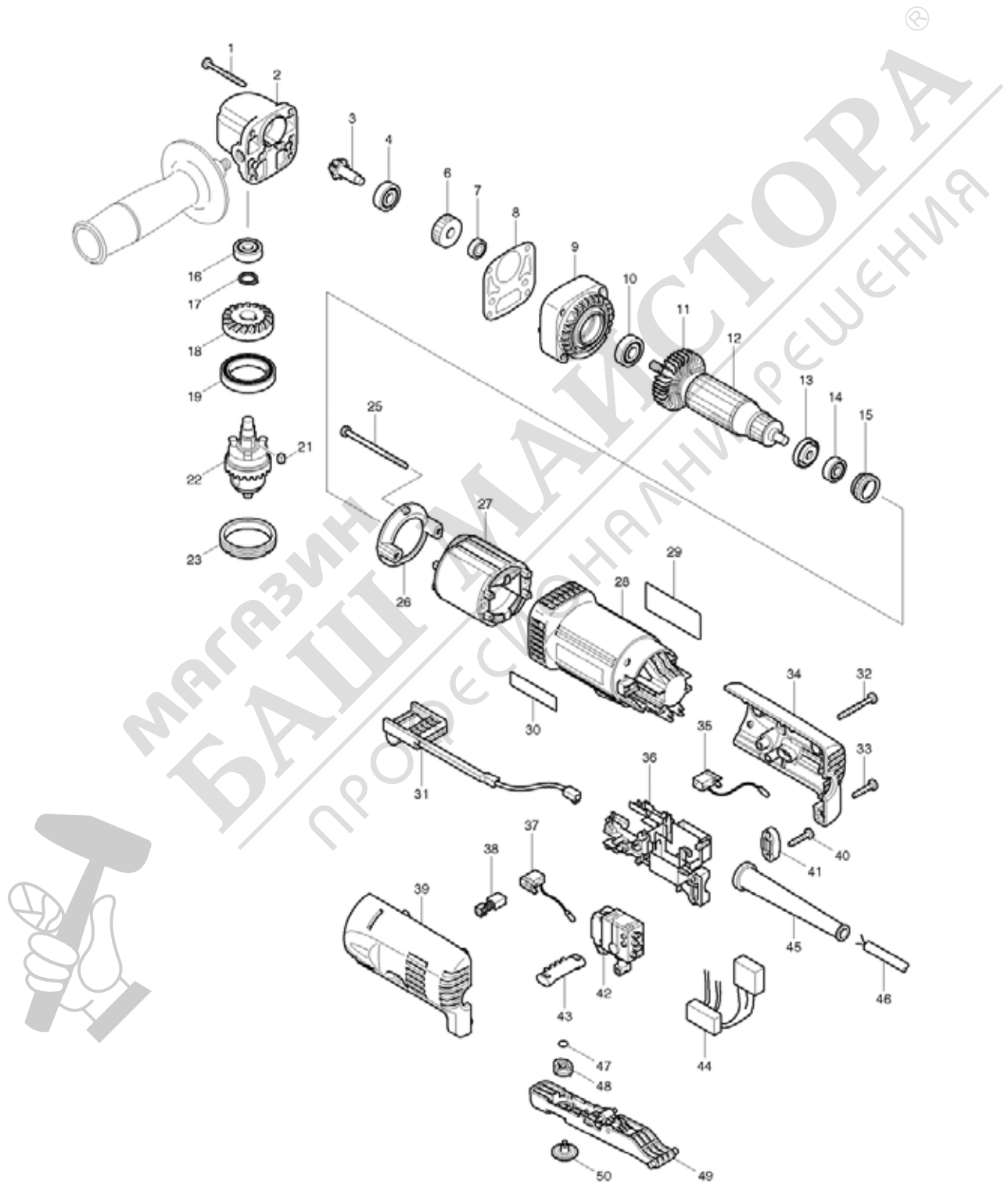



# Makita Werkzeug Ges.m.b.H.

Kolpingstrasse 13, 1230 Wien

Tel: 01 / 616 27 30 - 0\*

Fax: 01 / 616 27 30 - 40

Mail: verkauf@makita.at

Web: www.makita.at

## Makita Service Information / Model: DA3010F

POS	Bestell-Nr.	Artikelbeschreibung	Stk.	Stk.Preis
1	266048-4	SELBSTSCHNEID. SCHRAUBE 4x40	4	N/A
2	317635-3	GETRIEBEGEHÄUSE DA3010F/BDA34	1	N/A
2.2	317635-3	GETRIEBEGEHÄUSE DA3010F/BDA34	1	N/A
3	227436-0	ZAHNRAD 9 DA3010F/BDA340RFE	1	N/A
4	211031-6	KUGELLAGER 608LLB	1	N/A
4.2	210029-0	KUGELLAGER 608ZZ MT601/811/DA3	1	N/A
6	226567-2	ZAHNRAD 28 DA3010F/DA3011F	1	N/A
7	210026-6	KUGELLAGER 696ZZ neu	1	N/A
8	418036-9	DICHTUNG DA3010F/DA3011F/BDA4	1	N/A
9	418042-4	GETRIEBEGEHÄUSEDECKEL	1	N/A
10	211051-0	KUGELLAGER 609LLB	1	N/A
11	240061-0	LÜFTERRAD 48 DA3010F/DA3011F	1	N/A
12	517583-8	ANKER DA3010F/DA3011F	1	N/A
12		*** INC. 10,11,13,14		N/A
13	681636-0	ISOLIERSCHEIBE FS2300-6300	1	N/A
14	211021-9	KUGELLAGER 607LLB/HP1630/31K	1	N/A
15	421494-0	GUMMIRING 19	1	N/A
16	211031-6	KUGELLAGER 608LLB	1	N/A
16.2	210029-0	KUGELLAGER 608ZZ MT601/811/DA3	1	N/A
17	961052-5	SEEGERING S-12	1	N/A
18	227437-8	ZAHNRAD 26 DA3010F	1	N/A
19	211419-0	KUGELLAGER 6806DDW DA3010F	1	N/A
19.2	211423-9	KUGELLAGER 6806DDW BDA340RFE	1	N/A
21	254201-4	KEIL 4 8419B/DA3010F/11F/BDA	1	N/A
22	763174-5	ORIG. ZK-FUTTER 10MM DA3010F	1	N/A
23	285842-5	Lagerhaltering DA3010F/11F	1	N/A
25	266315-7	SELBSTSCHNEID. SCHRAUBE 4x65	2	N/A
26	418033-5	LUFTABLEITPLATTE DA3010F/11F/	1	N/A
27	635078-0	FELD DA3010F/DA3011F	1	N/A
28	183560-8	MOTORGEHÄUSE DA3010F/11F/JR10	1	N/A
28		*** INC. 30		N/A
29	850083-8	TYPENSCHILD DA3010F	1	N/A
30	819063-3	ETIKETTE " M A K I T A "	1	N/A
31	631516-0	Lichteinheit DA3010F/DA3011F	1	N/A
32	266053-1	SELBSTSCHNEID. SCHRAUBE 4x35	1	N/A
33	265995-6	SELBSTSCHN.SCHRA 4x18 BO5030	3	N/A
34	183559-3	MOTORGEHÄUSEDECKEL R+L	1	N/A
34		*** INC. 39		N/A
35	643801-9	KOHLLENHALTER DA3010F/DA3011F	1	N/A
36	687139-2	FELDANSCHLUSSPLATTE	1	N/A



## Makita Werkzeug Ges.m.b.H.

Kolpingstrasse 13, 1230 Wien

Tel: 01 / 616 27 30 - 0\*

Fax: 01 / 616 27 30 - 40

Mail: verkauf@makita.at

Web: www.makita.at

### Makita Service Information / Model: DA3010F

POS	Bestell-Nr.	Artikelbeschreibung	Stk.	Stk.Preis
37	643801-9	KOHLLENHALTER DA3010F/DA3011F	1	N/A
38	191962-4	KOHLLEN CB-419(CB-406/407)hp164	1	N/A
39	183559-3	MOTORGEHÄUSEDECKEL R+L	1	N/A
39		*** INC. 34		N/A
40	265995-6	SELBSTSCHN.SCHRA 4x18 BO5030	2	N/A
41	687063-9	KABELKLEMMPLATTE HT-345	1	N/A
42	650539-9	SCHALTER TG803BSA-1	1	N/A
43	418038-5	R/L Umschalthebel DA3010F/11F	1	N/A
44	631527-5	Stromkreiseinheit DA3010F/11F	1	N/A
45	682559-5	KABELSCHUTZ 8	1	N/A
46	666066-6	POWER SUPPLY CORD 1.0-2-2.5	1	N/A
47	213034-6	O-RING 3 DA3010F/DA3011F/JR1	1	N/A
48	418040-8	Nocke DA3010F/DA3011F/JR1000F	1	N/A
49	153477-9	SCHALTERHEBEL DA3010F/DA3011F	1	N/A
50	418037-7	Drehzahlscheibe DA3010F/11F/J	1	N/A
1001	411780-7	SCHLÜSSELHALTER ALLEIN 10MM H	1	N/A
1002	763415-9	BF-SCHLÜSSEL 10MM 8400DW/DA30	1	N/A
1003	152490-4	SEITL. GRIFF 36 (FÜR M8)	1	N/A

