

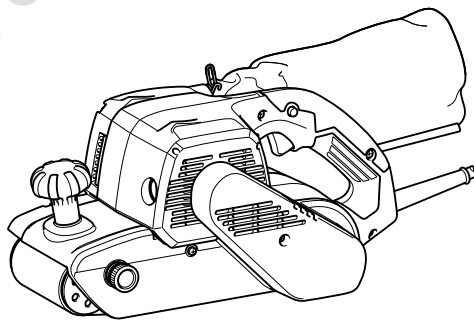

EN	Belt Sander	INSTRUCTION MANUAL	4
ZHCN	带式砂光机	使用说明书	8
ID	Mesin Ampelas Sabuk	PETUNJUK PENGGUNAAN	12
MS	Penggilap Tali Sawat	MANUAL ARAHAN	17
VI	Máy Chà Nhám Băng Cầm Tay Hoạt Động Bằng Động Cơ Điện	TÀI LIỆU HƯỚNG DẪN	22
TH	เครื่องขัดกระดาษทรายชนิดสายพาน	คู่มือการใช้งาน	26

M9400



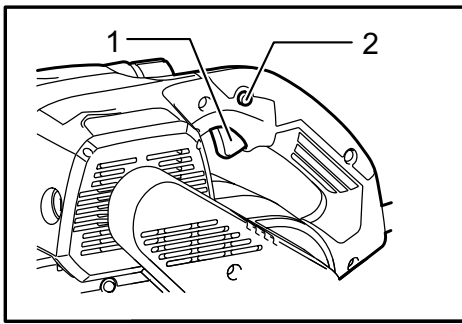

Fig.1

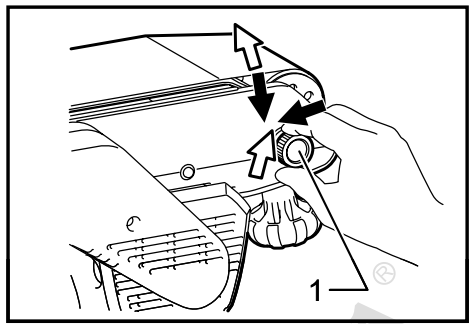

Fig.5

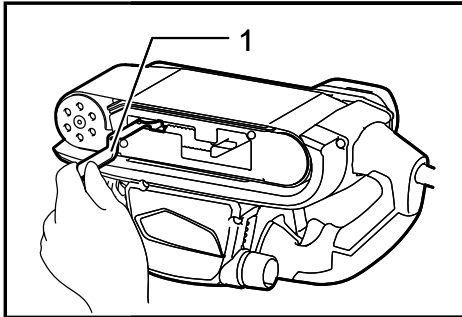

Fig.2

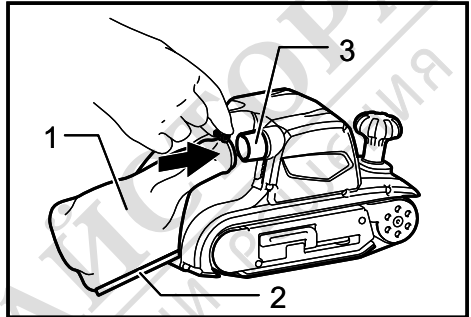

Fig.6

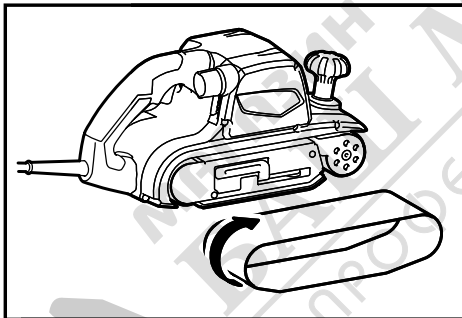

Fig.3

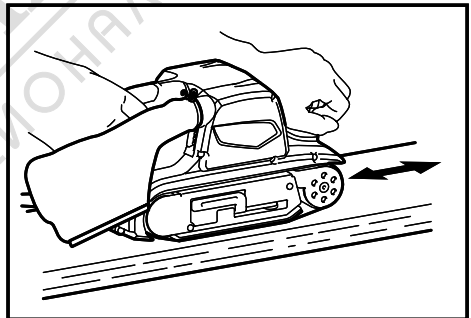

Fig.7

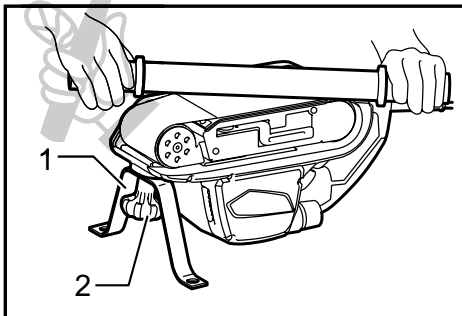

Fig.4

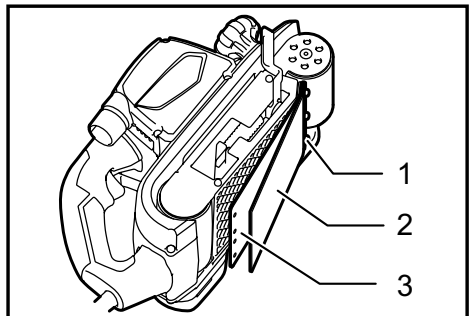

Fig.8

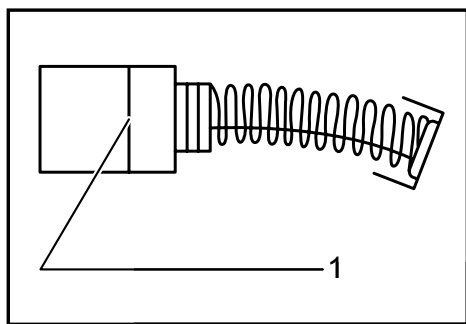

Fig.9

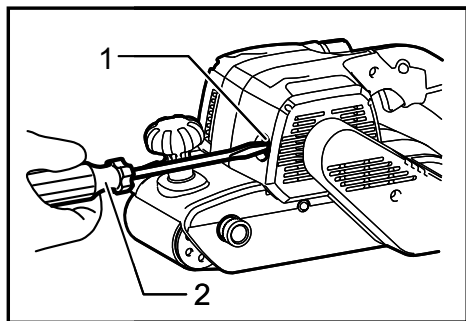

Fig.10

МАГАЗИН
БАШ МАЙСТОРА[®]
ПРОФЕСІОНАЛНИ РЕШЕННЯ







SPECIFICATIONS

Model	M9400
Belt size	100 mm x 610 mm
Belt speed	380 m/min
Overall length	354 mm
Net weight	6.2 kg
Safety class	□/II

- Due to our continuing program of research and development, the specifications herein are subject to change without notice.
- Specifications may differ from country to country.
- Weight according to EPTA-Procedure 01/2014

Symbols

The following show the symbols used for the equipment. Be sure that you understand their meaning before use.

	Read instruction manual.
	DOUBLE INSULATION
	Wear safety glasses.
	Only for EU countries Do not dispose of electric equipment together with household waste material! In observance of the European Directive, on Waste Electric and Electronic Equipment and its implementation in accordance with national law, electric equipment that have reached the end of their life must be collected separately and returned to an environmentally compatible recycling facility.

Intended use

The tool is intended for the sanding of large surface of wood, plastic and metal materials as well as painted surfaces.

Power supply

The tool should be connected only to a power supply of the same voltage as indicated on the nameplate, and can only be operated on single-phase AC supply. They are double-insulated and can, therefore, also be used from sockets without earth wire.

General power tool safety warnings

▲WARNING: Read all safety warnings, instructions, illustrations and specifications provided with this power tool. Failure to follow all instructions listed below may result in electric shock, fire and/or serious injury.

Save all warnings and instructions for future reference.

The term "power tool" in the warnings refers to your mains-operated (corded) power tool or battery-operated (cordless) power tool.

Work area safety

1. **Keep work area clean and well lit.** Cluttered or dark areas invite accidents.
2. **Do not operate power tools in explosive atmospheres, such as in the presence of flammable liquids, gases or dust.** Power tools create sparks which may ignite the dust or fumes.
3. **Keep children and bystanders away while operating a power tool.** Distractions can cause you to lose control.

Electrical safety

1. **Power tool plugs must match the outlet. Never modify the plug in any way. Do not use any adapter plugs with earthed (grounded) power tools.** Unmodified plugs and matching outlets will reduce risk of electric shock.
2. **Avoid body contact with earthed or grounded surfaces, such as pipes, radiators, ranges and refrigerators.** There is an increased risk of electric shock if your body is earthed or grounded.
3. **Do not expose power tools to rain or wet conditions.** Water entering a power tool will increase the risk of electric shock.
4. **Do not abuse the cord. Never use the cord for carrying, pulling or unplugging the power tool. Keep cord away from heat, oil, sharp edges or moving parts.** Damaged or entangled cords increase the risk of electric shock.

5. **When operating a power tool outdoors, use an extension cord suitable for outdoor use.** Use of a cord suitable for outdoor use reduces the risk of electric shock.
6. **If operating a power tool in a damp location is unavoidable, use a residual current device (RCD) protected supply.** Use of an RCD reduces the risk of electric shock.
7. **Use of power supply via an RCD with a rated residual current of 30 mA or less is always recommended.**
8. **Power tools can produce electromagnetic fields (EMF) that are not harmful to the user.** However, users of pacemakers and other similar medical devices should contact the maker of their device and/or doctor for advice before operating this power tool.
9. **Do not touch the power plug with wet hands.**
10. **If the cord is damaged, have it replaced by the manufacturer or his agent in order to avoid a safety hazard.**

Personal safety

1. **Stay alert, watch what you are doing and use common sense when operating a power tool.** Do not use a power tool while you are tired or under the influence of drugs, alcohol or medication. A moment of inattention while operating power tools may result in serious personal injury.
2. **Use personal protective equipment. Always wear eye protection.** Protective equipment such as a dust mask, non-skid safety shoes, hard hat or hearing protection used for appropriate conditions will reduce personal injuries.
3. **Prevent unintentional starting. Ensure the switch is in the off-position before connecting to power source and/or battery pack, picking up or carrying the tool.** Carrying power tools with your finger on the switch or energising power tools that have the switch on invites accidents.
4. **Remove any adjusting key or wrench before turning the power tool on.** A wrench or a key left attached to a rotating part of the power tool may result in personal injury.
5. **Do not overreach. Keep proper footing and balance at all times.** This enables better control of the power tool in unexpected situations.
6. **Dress properly. Do not wear loose clothing or jewellery. Keep your hair and clothing away from moving parts.** Loose clothes, jewellery or long hair can be caught in moving parts.
7. **If devices are provided for the connection of dust extraction and collection facilities, ensure these are connected and properly used.** Use of dust collection can reduce dust-related hazards.
8. **Do not let familiarity gained from frequent use of tools allow you to become complacent and ignore tool safety principles.** A careless action can cause severe injury within a fraction of a second.

9. **Always wear protective goggles to protect your eyes from injury when using power tools.** The goggles must comply with ANSI Z87.1 in the USA, EN 166 in Europe, or AS/NZS 1336 in Australia/New Zealand. In Australia/New Zealand, it is legally required to wear a face shield to protect your face, too.

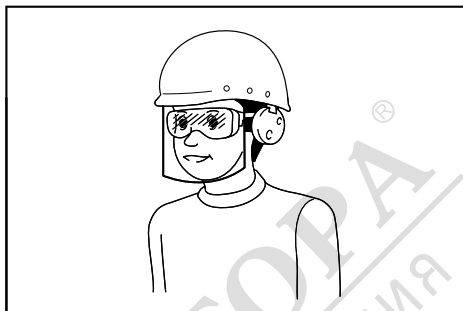

It is an employer's responsibility to enforce the use of appropriate safety protective equipments by the tool operators and by other persons in the immediate working area.

Power tool use and care

1. **Do not force the power tool. Use the correct power tool for your application.** The correct power tool will do the job better and safer at the rate for which it was designed.
2. **Do not use the power tool if the switch does not turn it on and off.** Any power tool that cannot be controlled with the switch is dangerous and must be repaired.
3. **Disconnect the plug from the power source and/or remove the battery pack, if detachable, from the power tool before making any adjustments, changing accessories, or storing power tools.** Such preventive safety measures reduce the risk of starting the power tool accidentally.
4. **Store idle power tools out of the reach of children and do not allow persons unfamiliar with the power tool or these instructions to operate the power tool.** Power tools are dangerous in the hands of untrained users.
5. **Maintain power tools and accessories. Check for misalignment or binding of moving parts, breakage of parts and any other condition that may affect the power tool's operation.** If damaged, have the power tool repaired before use. Many accidents are caused by poorly maintained power tools.
6. **Keep cutting tools sharp and clean.** Properly maintained cutting tools with sharp cutting edges are less likely to bind and are easier to control.
7. **Use the power tool, accessories and tool bits etc. in accordance with these instructions, taking into account the working conditions and the work to be performed.** Use of the power tool for operations different from those intended could result in a hazardous situation.

8. **Keep handles and grasping surfaces dry, clean and free from oil and grease.** Slippery handles and grasping surfaces do not allow for safe handling and control of the tool in unexpected situations.
9. **When using the tool, do not wear cloth work gloves which may be entangled.** The entanglement of cloth work gloves in the moving parts may result in personal injury.

Service

1. **Have your power tool serviced by a qualified repair person using only identical replacement parts.** This will ensure that the safety of the power tool is maintained.
2. **Follow instruction for lubricating and changing accessories.**

BELT SANDER SAFETY WARNINGS

1. **Hold the power tool by insulated gripping surfaces, because the sanding surface may contact its own cord.** Cutting a "live" wire may make exposed metal parts of the power tool "live" and could give the operator an electric shock.
2. **Ventilate your work area adequately when you perform sanding operations.**
3. **Some material contains chemicals which may be toxic. Take caution to prevent dust inhalation and skin contact. Follow material supplier safety data.**
4. **Always use the correct dust mask/respirator for the material and application you are working with.**
5. **Always use safety glasses or goggles. Ordinary eye or sun glasses are NOT safety glasses.**
6. **Hold the tool firmly with both hands.**
7. **Make sure the belt is not contacting the workpiece before the switch is turned on.**
8. **Keep hands away from rotating parts.**
9. **Do not leave the tool running. Operate the tool only when hand-held.**
10. **This tool has not been waterproofed, so do not use water on the workpiece surface.**

SAVE THESE INSTRUCTIONS.

⚠WARNING: DO NOT let comfort or familiarity with product (gained from repeated use) replace strict adherence to safety rules for the subject product. MISUSE or failure to follow the safety rules stated in this instruction manual may cause serious personal injury.

FUNCTIONAL DESCRIPTION

⚠CAUTION:

- Always be sure that the tool is switched off and unplugged before adjusting or checking function on the tool.

Switch action

► Fig.1: 1. Switch trigger 2. Lock button

⚠CAUTION:

- Before plugging in the tool, always check to see that the switch trigger actuates properly and returns to the "OFF" position when released.

To start the tool, simply pull the switch trigger. Release the switch trigger to stop.

For continuous operation, pull the switch trigger and then push in the lock button, and then release the switch trigger.

To stop the tool from the locked position, pull the switch trigger fully, and then release it.

ASSEMBLY

⚠CAUTION:

- Always be sure that the tool is switched off and unplugged before carrying out any work on the tool.

Installing or removing abrasive belt

► Fig.2: 1. Lever

Pull the lever all the way out and install the belt over the rollers, and then return the lever to the original position.

⚠CAUTION:

- When installing the belt, make sure that the direction of the arrow on the back of the belt corresponds to the one on the tool itself.

► Fig.3

Installing or removing step

► Fig.4: 1. Step 2. Knob

Using step with the tool turned upside down allows sanding another way of use. Remove the knob and then place the step on the place the knob was seated and secure it with knob.

Adjusting belt tracking

► Fig.5: 1. Adjusting knob

While the belt is running, use the adjusting knob to center the belt tracking. Failure to do so can result in frayed belt edges and wear on the sander frame.

Dust bag

► **Fig.6:** 1. Dust bag 2. Fastener 3. Dust spout

The use of the dust bag makes sanding operations clean and dust collection easy. To attach the dust bag, fit it onto the dust spout.

When the dust bag is about half full, remove the dust bag from the tool and pull the fastener out. Empty the dust bag of its contents, tapping it lightly so as to remove particles adhering to the insides which might hamper further collection.

OPERATION

Sanding operation

► **Fig.7**

⚠ CAUTION:

- The tool should not be in contact with the workpiece surface when you turn the tool on or off. Otherwise a poor sanding finish or damage of the belt may result.

Hold the tool firmly with both hands. Turn the tool on and wait until it attains full speed. Then gently place the tool on the workpiece surface. Keep the belt flush with the workpiece at all times and move the tool back and forth.

Never force the tool. The weight of the tool applies adequate pressure. Excessive pressure may cause stalling, overheating of the motor, burning of the workpiece and possible kickback.

MAINTENANCE

⚠ CAUTION:

- Always be sure that the tool is switched off and unplugged before attempting to perform inspection or maintenance.
- Never use gasoline, benzine, thinner, alcohol or the like. Discoloration, deformation or cracks may result.

Replacing carbon plate

► **Fig.8:** 1. Strap washer 2. Cork rubber plate 3. Carbon plate

Replace an carbon plate on the cork rubber plate when it is worn down. Remove screws on the strap washer and the worn carbon plate, place a new carbon plate and then secure it with the screws.

Replacing carbon brushes

► **Fig.9:** 1. Limit mark

Remove and check the carbon brushes regularly. Replace them when they are worn down to the limit mark. Keep the carbon brushes clean and free to slip in the holders. Both carbon brushes should be replaced at the same time. Use only identical carbon brushes. Use a screwdriver to remove the brush holder caps. Take out the worn carbon brushes, insert the new ones and secure the brush holder caps.

► **Fig.10:** 1. Brush holder cap 2. Screwdriver

To maintain product SAFETY and RELIABILITY, repairs, any other maintenance or adjustment should be performed by Makita Authorized Service Centers, always using Makita replacement parts.

