

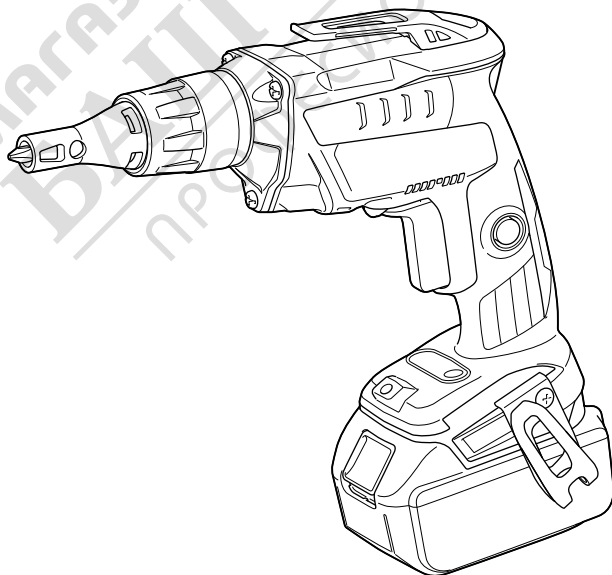

GB	Cordless Screwdriver	Instruction Manual
F	Visseuse sans Fil	Manuel d'instructions
D	Akku-Schrauber	Betriebsanleitung
I	Avvitatore a batteria	Istruzioni per l'uso
NL	Snoerloze schroevendraaier	Gebruiksaanwijzing
E	A tornillador Inalámbrico	Manual de instrucciones
P	Parafusadeira a Bateria	Manual de instruções
DK	Akku skruemaskine	Brugsanvisning
GR	Ασύρματο κατσαβίδι	Οδηγίες χρήσεως
TR	Akülü Tornavida	Kullanma kılavuzu

DFS452

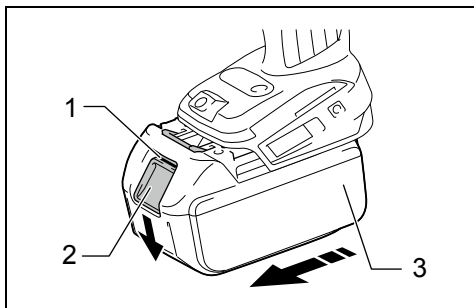



1 015161

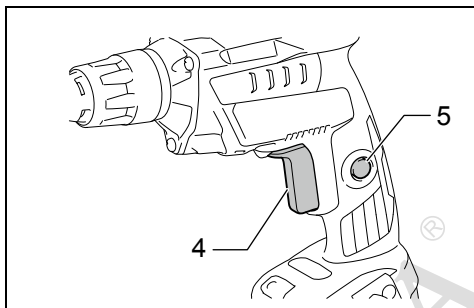

2 015162

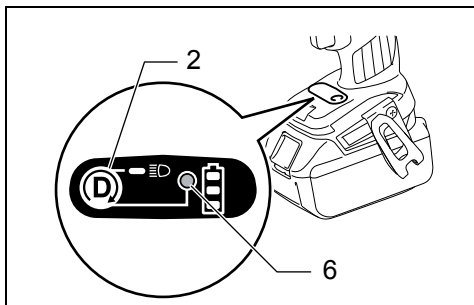

3 015173

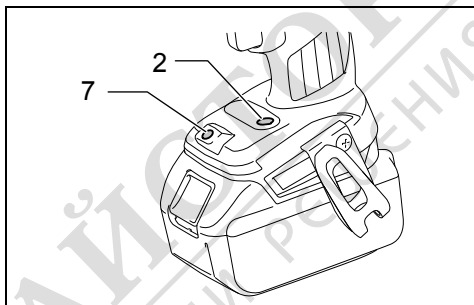

4 015163

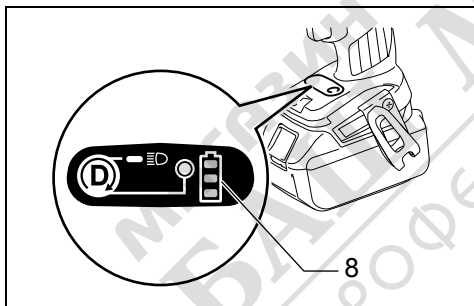

5 015174

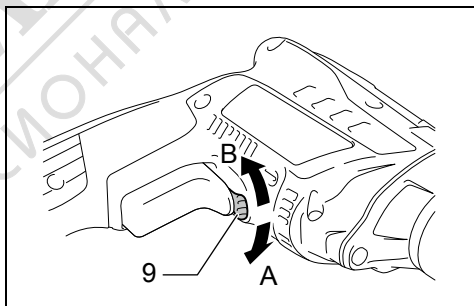

6 015164

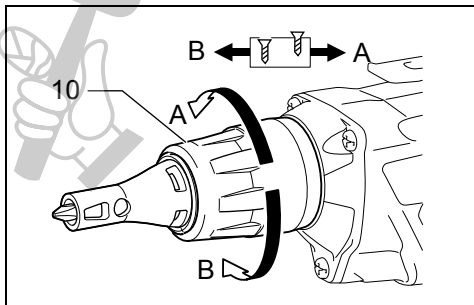

7 015165

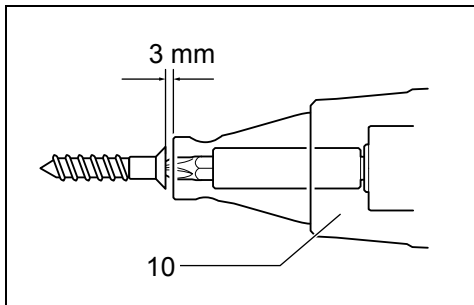

8 011815

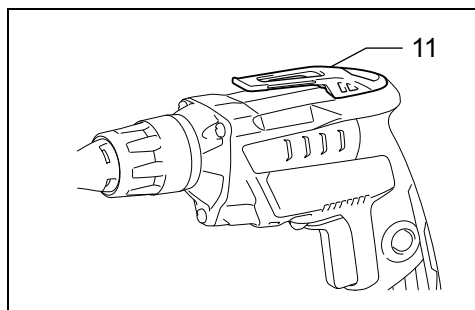

9 015170

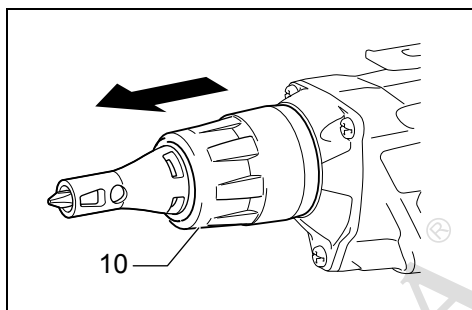

10 015166

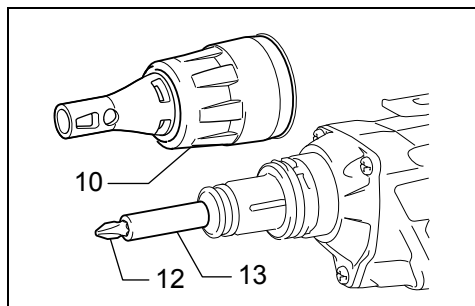

11 015167

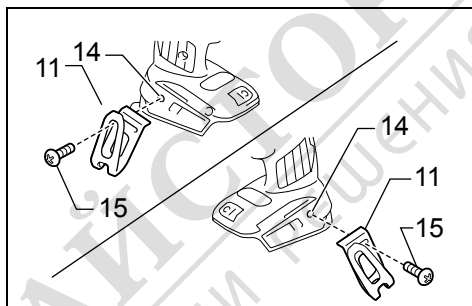

12 015168

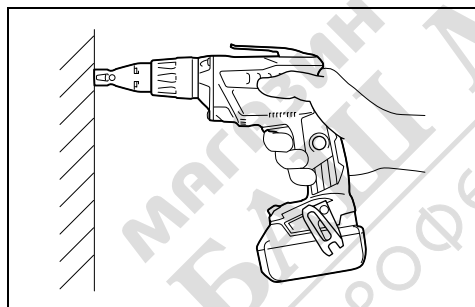

13 015169



Explanation of general view

1 Red indicator	6 Mode indicator	11 Hook
2 Button	7 Lamp	12 Bit
3 Battery cartridge	8 Battery indicator	13 Magnetic bit holder
4 Switch trigger	9 Reversing switch lever	14 Groove
5 Lock button	10 Locator	15 Screw

SPECIFICATIONS

Model		DFS452
Capacities	Self drilling screw	6 mm
	Drywall screw	5 mm
No load speed		0 – 4,000 min ⁻¹
Overall length	With short locator	235 mm
	With long locator	251 mm
Net weight		1.7 kg
Rated voltage		D.C. 18 V

- Due to our continuing program of research and development, the specifications herein are subject to change without notice.
- Specifications and battery cartridge may differ from country to country.
- Weight, with battery cartridge, according to EPTA-Procedure 01/2003

ENE033-1

Intended use

The tool is intended for screw driving in wood, metal and plastic.

GEA010-1

General Power Tool Safety Warnings

⚠ WARNING Read all safety warnings and all instructions. Failure to follow the warnings and instructions may result in electric shock, fire and/or serious injury.

Save all warnings and instructions for future reference.

GEB050-2

CORDLESS SCREWDRIVER SAFETY WARNINGS

1. Hold power tool by insulated gripping surfaces, when performing an operation where the fastener may contact hidden wiring. Fasteners contacting a "live" wire may make exposed metal parts of the power tool "live" and could give the operator an electric shock.
2. Always be sure you have a firm footing. Be sure no one is below when using the tool in high locations.
3. Hold the tool firmly.
4. Keep hands away from rotating parts.

5. Do not touch the bit or the workpiece immediately after operation; they may be extremely hot and could burn your skin.

SAVE THESE INSTRUCTIONS.

⚠ WARNING:

DO NOT let comfort or familiarity with product (gained from repeated use) replace strict adherence to safety rules for the subject product. MISUSE or failure to follow the safety rules stated in this instruction manual may cause serious personal injury.

ENC007-8

IMPORTANT SAFETY INSTRUCTIONS

FOR BATTERY CARTRIDGE

1. Before using battery cartridge, read all instructions and cautionary markings on (1) battery charger, (2) battery, and (3) product using battery.
2. Do not disassemble battery cartridge.
3. If operating time has become excessively shorter, stop operating immediately. It may result in a risk of overheating, possible burns and even an explosion.
4. If electrolyte gets into your eyes, rinse them out with clear water and seek medical attention right away. It may result in loss of your eyesight.
5. Do not short the battery cartridge:
 - (1) Do not touch the terminals with any conductive material.
 - (2) Avoid storing battery cartridge in a container with other metal objects such as nails, coins, etc.
 - (3) Do not expose battery cartridge to water or rain.

A battery short can cause a large current flow, overheating, possible burns and even a breakdown.

6. Do not store the tool and battery cartridge in locations where the temperature may reach or exceed 50°C (122°F).
7. Do not incinerate the battery cartridge even if it is severely damaged or is completely worn out. The battery cartridge can explode in a fire.
8. Be careful not to drop or strike battery.
9. Do not use a damaged battery.
10. Follow your local regulations relating to disposal of battery.

SAVE THESE INSTRUCTIONS.

Tips for maintaining maximum battery life

1. Charge the battery cartridge before completely discharged.
Always stop tool operation and charge the battery cartridge when you notice less tool power.
2. Never recharge a fully charged battery cartridge. Overcharging shortens the battery service life.
3. Charge the battery cartridge with room temperature at 10°C – 40°C (50°F – 104°F). Let a hot battery cartridge cool down before charging it.
4. Charge the battery cartridge once in every six months if you do not use it for a long period of time.

FUNCTIONAL DESCRIPTION

⚠ CAUTION:

- Always be sure that the tool is switched off and the battery cartridge is removed before adjusting or checking function on the tool.

Installing or removing battery cartridge (Fig. 1)

⚠ CAUTION:

- Always switch off the tool before installing or removing of the battery cartridge.
- Hold the tool and the battery cartridge firmly when installing or removing battery cartridge. Failure to hold the tool and the battery cartridge firmly may cause them to slip off your hands and result in damage to the tool and battery cartridge and a personal injury.

To remove the battery cartridge, slide it from the tool while sliding the button on the front of the cartridge.

To install the battery cartridge, align the tongue on the battery cartridge with the groove in the housing and slip it into place. Insert it all the way until it locks in place with a little click. If you can see the red indicator on the upper side of the button, it is not locked completely.

⚠ CAUTION:

- Always install the battery cartridge fully until the red indicator cannot be seen. If not, it may accidentally fall out of the tool, causing injury to you or someone around you.
- Do not install the battery cartridge forcibly. If the cartridge does not slide in easily, it is not being inserted correctly.

Switch action (Fig. 2)

⚠ CAUTION:

- Before inserting the battery cartridge into the tool, always check to see that the switch trigger actuates properly and returns to the “OFF” position when released.

- Switch can be locked in “ON” position for ease of operator comfort during extended use. Apply caution when locking tool in “ON” position and maintain firm grasp on tool.

To start the tool, simply pull the switch trigger. Tool speed is increased by increasing pressure on the switch trigger. Release the switch trigger to stop.

For continuous operation, pull the switch trigger, push in the lock button and then release the trigger.

To stop the tool from the locked position, pull the switch trigger fully, and then release it.

NOTE:

- Even with the switch on and motor running, the bit does not rotate. Push the tool forward to engage the clutch.
- The tool automatically stops if the motor keeps rotating for about 6 minutes.

Push drive mode (Fig. 3)

This tool has push drive mode. In this mode, the tool cuts off power to the motor to save the battery power at idle.

To select push drive mode, pull the trigger slightly, then release it and quickly press the button. The mode indicator will then light up.

Once push drive is activated, pull the switch trigger and then push the lock button. Apply pressure to the bit and the motor will start rotating. Further pressure engages the clutch and the bit will start rotating. In push drive mode, the motor and the driver bit will only rotate by applying pressure.

NOTE:

- If the tool does not run for about 8 hours in push drive mode with the trigger locked on, tool is shutdown. In such a case, release and pull the trigger again for restarting.

Lighting up the lamp (Fig. 4)

To turn on the lamp, slightly pull the switch trigger, release it and then press the button for a few seconds. The lamp turns on. The lamp goes out approximately 10 seconds after releasing the switch trigger. To turn on the lamp again, slightly pull the switch trigger again.

To keep turning off the light, slightly pull the switch trigger and release it. Then press the button a few seconds.

In push drive mode with the switch trigger locked, the lamp goes out approximately one minute after the motor stops.







NOTE:

- While pulling the switch trigger, the lamp mode cannot be changed.
- For approximately 10 seconds after releasing the switch trigger, the lamp mode can be changed.
- Use a dry cloth to wipe the dirt off the lens of lamp. Be careful not to scratch the lens of lamp, or it may lower the illumination.

Indicating remaining battery capacity (Fig. 5)

When you pull the switch trigger, the battery indicator shows the remaining battery capacity.

The remaining battery capacity is shown as the following table.

Battery indicator status	Remaining battery capacity
 : On  : Off  : Blinking	
	50% – 100%
	20% – 50%
	0% – 20%
	Charge the battery

015175

NOTE:

- Approximately one minute after the motor stops, the indicators go off to save the battery power. To check the remaining battery capacity, slightly pull the switch trigger.

Tool / battery protection system

The tool is equipped with a tool/battery protection system. This system automatically cuts off power to the motor to extend tool and battery life.





The tool will automatically stop during operation if the tool or battery are placed under one of the following conditions. In some conditions, the indicator lights up.

Overload protection

When the tool is operated in a manner that causes it to draw an abnormally high current, the tool automatically stops without any indications. In this situation, turn the tool off and stop the application that caused the tool to become overloaded. Then turn the tool on to restart.

Overheat protection for tool

When the tool is overheated, the tool stops automatically and the battery indicator shows following state. In this situation, let the tool cool before turning the tool on again.

Battery indicator	 : On  : Off  : Blinking
	Tool is overheated

015176

Reversing switch action (Fig. 6)

⚠ CAUTION:

- Always check the direction of rotation before operation.
- Use the reversing switch only after the tool comes to a complete stop. Changing the direction of rotation before the tool stops may damage the tool.

This tool has a reversing switch to change the direction of rotation. Move the reversing switch lever to the ⇐ position (A side) for clockwise rotation or the ⇒ position (B side) for counterclockwise rotation.

When the reversing switch lever is in the neutral position, the switch trigger cannot be pulled.

⚠ CAUTION:

- When not operating the tool, always set the reversing switch lever to the neutral position.

Depth adjustment (Fig. 7 & 8)

The depth can be adjusted by turning the locator. Turn it in "B" direction for less depth and in "A" direction for more depth. One full turn of the locator equals 2 mm change in depth.

Adjust the locator so that the distance between the tip of the locator and the screw head is approximately 3 mm as shown in the figures. Drive a trial screw into your material or a piece of duplicate material. If the depth is still not suitable for the screw, continue adjusting until you obtain the proper depth setting.

Hook (Fig. 9)

⚠ CAUTION:

- Always remove the battery when hanging the tool with the hook.
- Never hook the tool at high location or on potentially unstable surface.

The hook is convenient for temporarily hanging the tool.

ASSEMBLY

⚠ CAUTION:

- Always be sure that the tool is switched off and the battery cartridge is removed before carrying out any work on the tool.

Installing or removing the bit (Fig. 10 & 11)

To remove the bit, pull the locator. Then grasp the bit with a pair of pliers and pull the bit out of the magnetic bit holder. Sometimes, it helps to wiggle the bit with the pliers as you pull.

To install the bit, push it firmly into the magnetic bit holder. Then install the locator by pushing it firmly back.

Hook (Fig. 12)

The hook is convenient for temporarily hanging the tool. This can be installed on either side of the tool.

To install the hook, insert it into a groove in the tool housing on either side and then secure it with a screw. To remove, loosen the screw and then take it out.

OPERATION

Screwdriving operation (Fig. 13)

Fit the screw on the point of the bit and place the point of the screw on the surface of the workpiece to be fastened. Apply pressure to the tool and start it. Withdraw the tool as soon as the clutch cuts in. Then release the switch trigger.

⚠ CAUTION:

- When fitting the screw onto the point of the bit, be careful not to push in on the screw. If the screw is pushed in, the clutch will engage and the screw will rotate suddenly. This could damage a workpiece or cause an injury.
- Make sure that the bit is inserted straight in the screw head, or the screw and/or bit may be damaged.

MAINTENANCE

⚠ CAUTION:

- Always be sure that the tool is switched off and the battery cartridge is removed before attempting to perform inspection or maintenance.
- Never use gasoline, benzine, thinner, alcohol or the like. Discoloration, deformation or cracks may result.

To maintain product SAFETY and RELIABILITY, repairs, carbon brush inspection and replacement, any other maintenance or adjustment should be performed by Makita Authorized Service Centers, always using Makita replacement parts.

OPTIONAL ACCESSORIES

⚠ CAUTION:

- These accessories or attachments are recommended for use with your Makita tool specified in this manual. The use of any other accessories or attachments might present a risk of injury to persons. Only use accessory or attachment for its stated purpose.

If you need any assistance for more details regarding these accessories, ask your local Makita Service Center.

- Phillips Insert bits
- Magnetic bit holder
- Makita genuine battery and charger
- Plastic carrying case

NOTE:

- Some items in the list may be included in the tool package as standard accessories. They may differ from country to country.

Noise

ENG905-1

The typical A-weighted noise level determined according to EN60745:

Sound pressure level (L_{pA}): 72 dB (A)
Uncertainty (K): 3 dB (A)

The noise level under working may exceed 80 dB (A).

Wear ear protection

Vibration

ENG900-1

The vibration total value (tri-axial vector sum) determined according to EN60745:

Work mode: screwdriving without impact
Vibration emission (a_h): 2.5 m/s² or less
Uncertainty (K): 1.5 m/s²

ENG901-1

- The declared vibration emission value has been measured in accordance with the standard test method and may be used for comparing one tool with another.
- The declared vibration emission value may also be used in a preliminary assessment of exposure.

⚠ WARNING:

- The vibration emission during actual use of the power tool can differ from the declared emission value depending on the ways in which the tool is used.
- Be sure to identify safety measures to protect the operator that are based on an estimation of exposure in the actual conditions of use (taking account of all parts of the operating cycle such as the times when the tool is switched off and when it is running idle in addition to the trigger time).

ENH101-18

For European countries only

EC Declaration of Conformity

Makita declares that the following Machine(s):

Designation of Machine:
Cordless Screwdriver
Model No./ Type: DFS452

Conforms to the following European Directives: 2006/42/EC

They are manufactured in accordance with the following standard or standardized documents:

EN60745

The technical file in accordance with 2006/42/EC is available from:

Makita, Jan-Baptist Vinkstraat 2, 3070, Belgium

7.3.2014



Yasushi Fukaya
Director

Makita, Jan-Baptist Vinkstraat 2, 3070, Belgium