

- D** Originalbetriebsanleitung
Akku-Handkreissäge
- GB** Original operating instructions
Cordless Handheld Circular Saw
- F** Instructions d'origine
Scie circulaire portable
- I** Istruzioni per l'uso originali
Sega circolare a batteria
- DK/N** Original betjeningsvejledning
Akku-håndrundsav
- S** Original-bruksanvisning
Batteridrivnen handcirkelsåg
- CZ** Originální návod k obsluze
Akumulátorová ruční kotoučová
- SK** Originálny návod na obsluhu
Akumulátorová ručná okružná píla
- NL** Originele handleiding
Accu-handcirkelzaag
- E** Manual de instrucciones original
Sierra circular de mano con batería
- FIN** Alkuperäiskäyttöohje
Akkukäyttöinen käsipyörösaha
- SLO** Originalna navodila za uporabo
Akumulatorska ročna krožna žaga
- H** Eredeti használati utasítás
Akkus-kézi körfűrész
- RO** Instrucțiuni de utilizare originale
Ferăstrău circular manual cu acumulator
- GR** Πρωτότυπες Οδηγίες χρήσης
Δισκοπίριο χεριού, με μπαταρία
- P** Manual de instruções original
Serra circular manual sem fio
- HR/BIH** Originalne upute za uporabu
Akumulatorska ručna kružna pila
- RS** Originalna uputstva za upotrebu
Akumulatorska ručna kružna tes-
tera
- PL** Instrukcja oryginalną
Akumulatorowa ręczna pilarka tar-
czowa
- TR** Orijinal Kullanma Talimatı
Akülü sunta kesme
- RUS** Оригинальное руководство по
эксплуатации
Аккумуляторная дисковая
ручная пила
- EE** Originaalkasutusjuhend
Akuga käsikreissaag

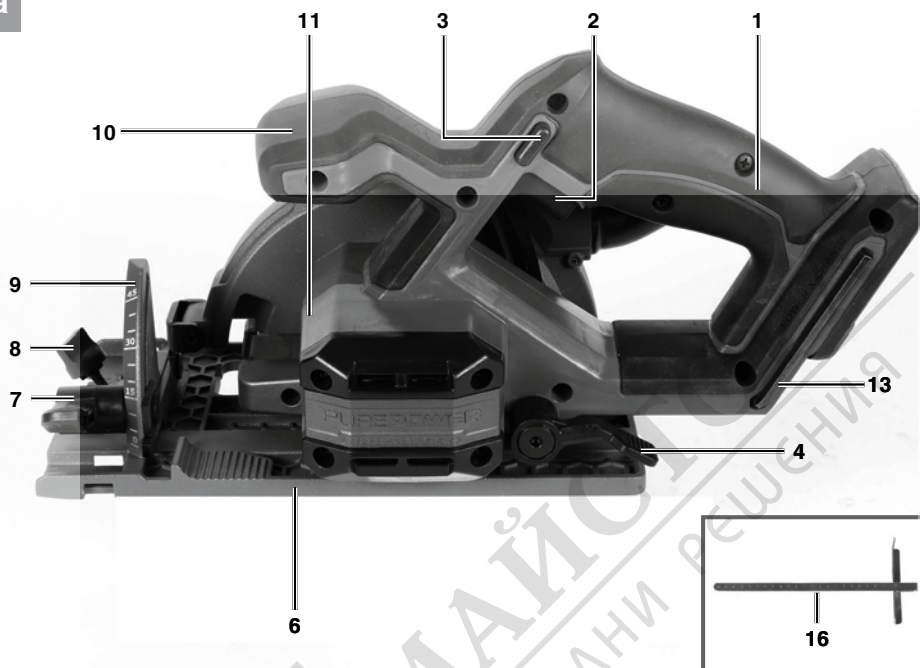

1a



1b

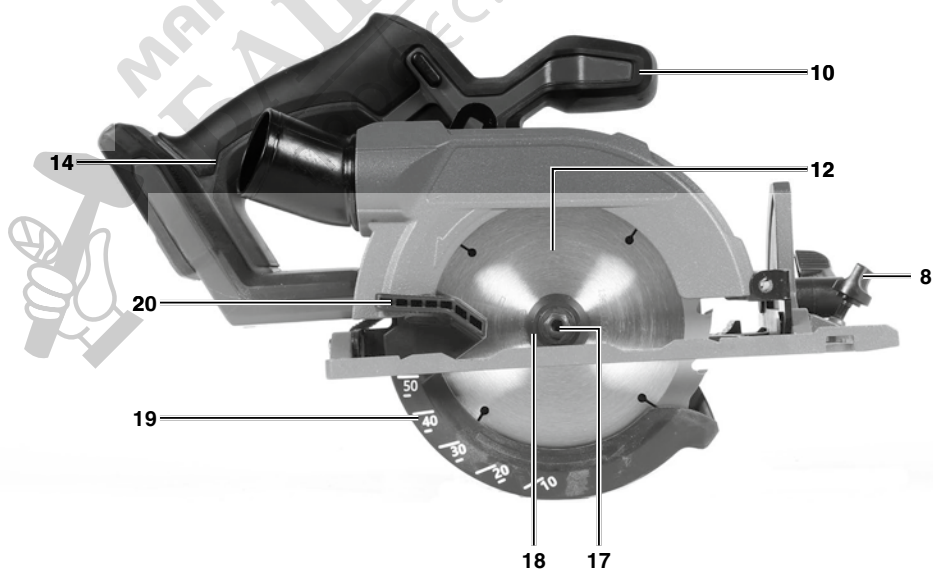

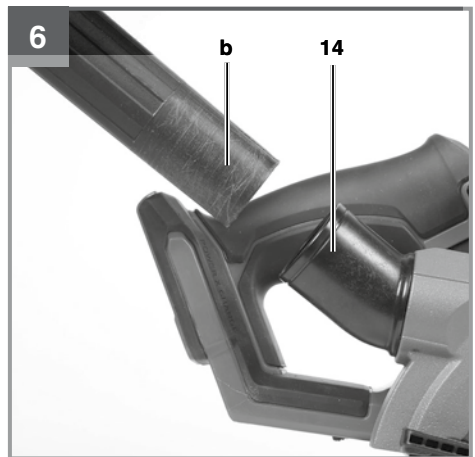
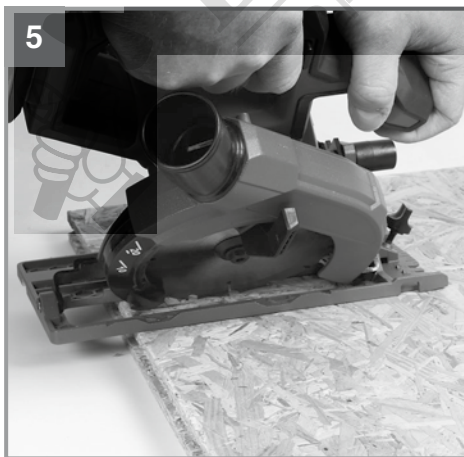
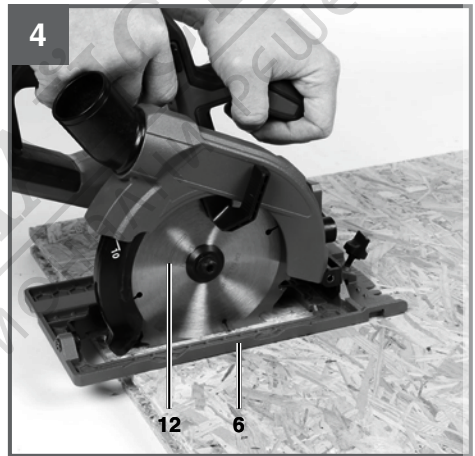
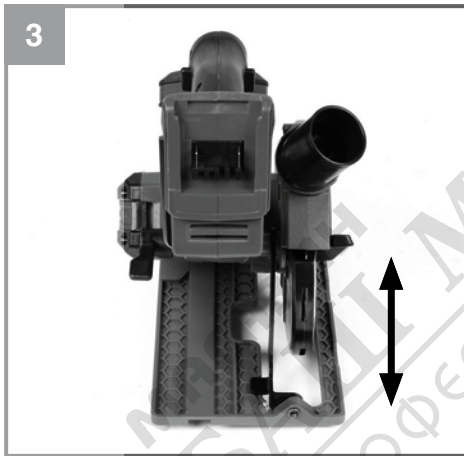
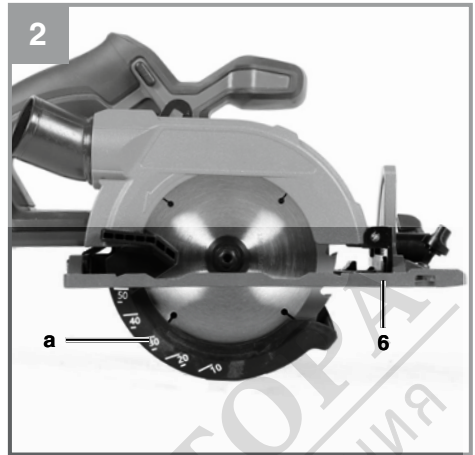
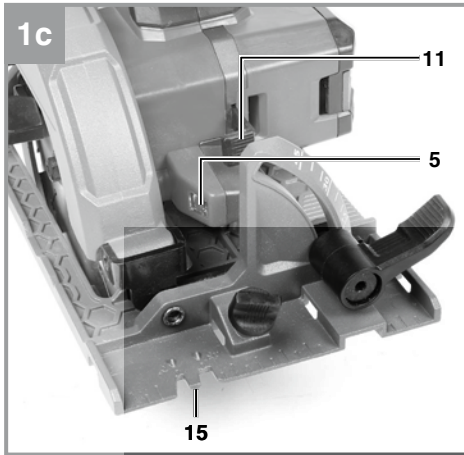

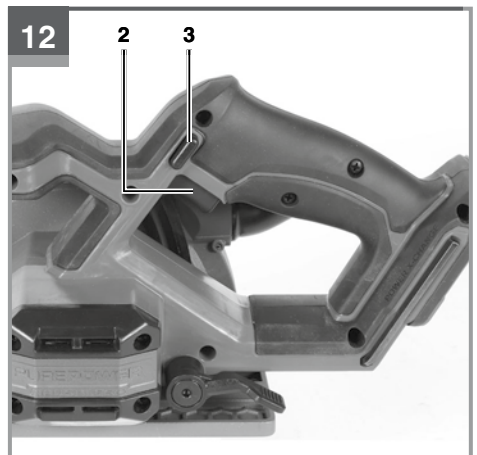
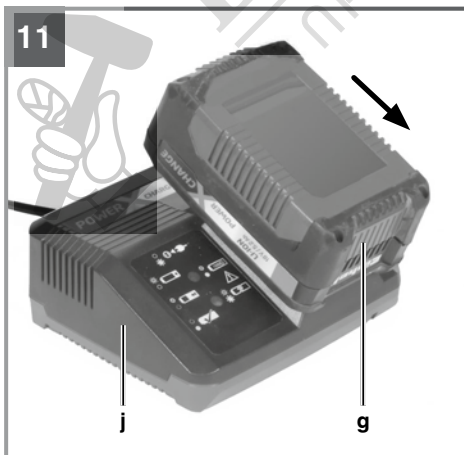
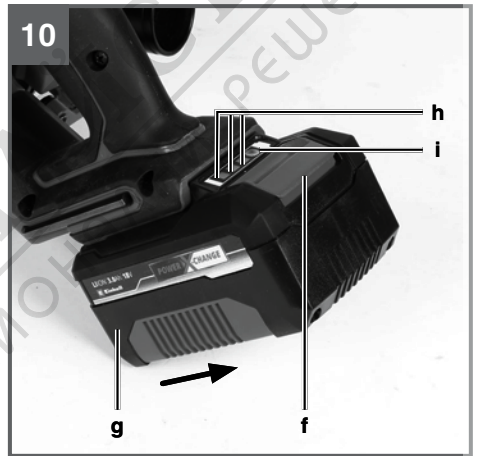
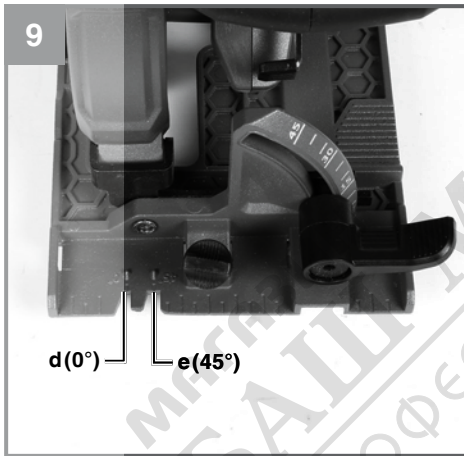
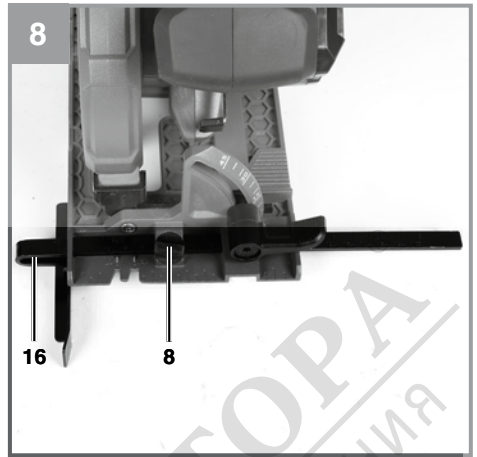
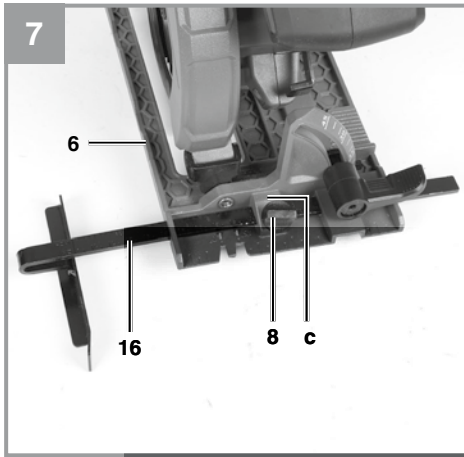

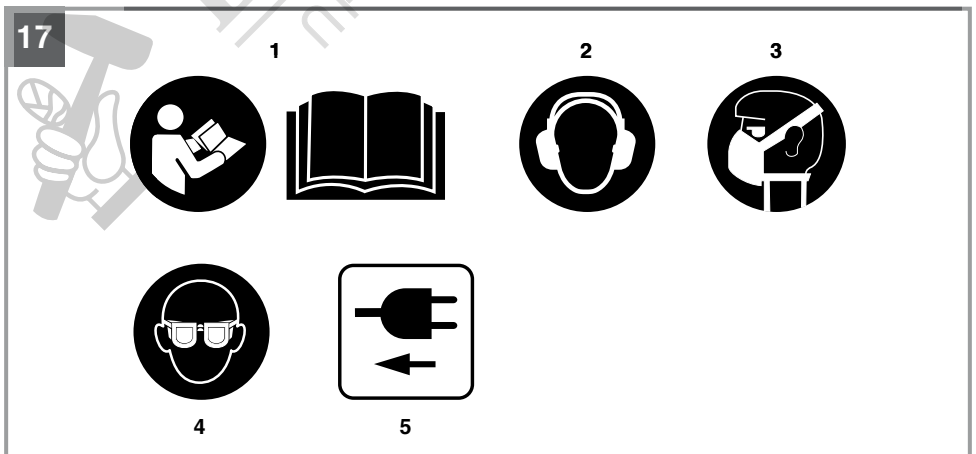
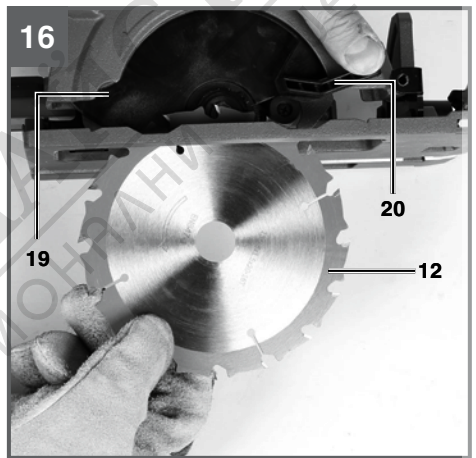
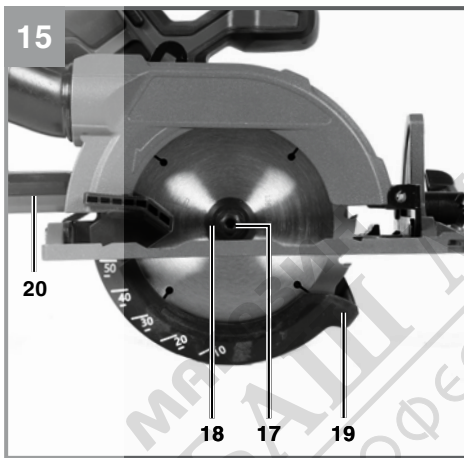
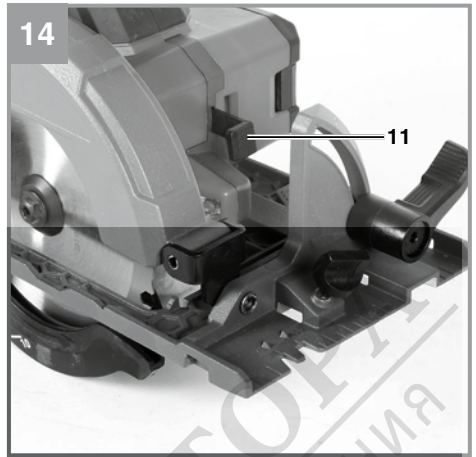
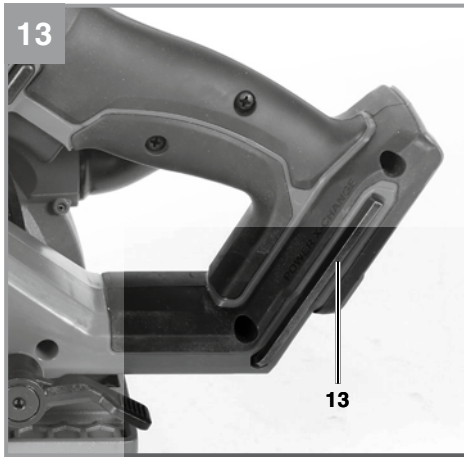

Danger!

When using the equipment, a few safety precautions must be observed to avoid injuries and damage. Please read the complete operating instructions and safety regulations with due care. Keep this manual in a safe place, so that the information is available at all times. If you give the equipment to any other person, hand over these operating instructions and safety regulations as well. We cannot accept any liability for damage or accidents which arise due to a failure to follow these instructions and the safety instructions.

Explanation of the symbols used (see Fig. 17)

1. **Danger!** - Read the operating instructions to reduce the risk of injury.
2. **Caution! Wear ear-muffs.** The impact of noise can cause damage to hearing.
3. **Caution! Wear a breathing mask.** Dust which is injurious to health can be generated when working on wood and other materials. Never use the device to work on any materials containing asbestos!
4. **Caution! Wear safety goggles.** Sparks generated during working or splinters, chips and dust emitted by the device can cause loss of sight.
5. **Pull out the plug or battery pack!**

1. Safety regulations

The corresponding safety information can be found in the enclosed booklet.

Warning!

Read all the safety information, instructions, illustrations and technical data provided on or with this power tool. Failure to adhere to the following instructions may result in electric shock, fire and/or serious injury.

Keep all the safety information and instructions in a safe place for future use.

2. Layout and items supplied**2.1 Layout (Fig. 1a/1b/1c)**

1. Handle
2. ON/OFF switch
3. Locking button for ON/OFF switch
4. Locking lever for cutting depth setting
5. LED lamp
6. Soleplate
7. Locking lever for miter setting

8. Locking screw for parallel stop
9. Scale for miter angle
10. Additional handle
11. Spindle lock
12. Saw blade
13. Saw blade wrench
14. Connection for sawdust extractor
15. Line guide
16. Parallel stop
17. Screw for securing the saw blade
18. Flange
19. Swing guard hood
20. Lever for swing guard hood

2.2 Items supplied

Please check that the article is complete as specified in the scope of delivery. If parts are missing, please contact our service center or the sales outlet where you made your purchase at the latest within 5 working days after purchasing the product and upon presentation of a valid bill of purchase. Also, refer to the warranty table in the service information at the end of the operating instructions.

- Open the packaging and take out the equipment with care.
- Remove the packaging material and any packaging and/or transportation braces (if available).
- Check to see if all items are supplied.
- Inspect the equipment and accessories for transport damage.
- If possible, please keep the packaging until the end of the guarantee period.

Danger!

The equipment and packaging material are not toys. Do not let children play with plastic bags, foils or small parts. There is a danger of swallowing or suffocating!

- Cordless Handheld Circular Saw
- Saw blade
- Saw blade wrench
- Parallel stop
- Original operating instructions
- Safety instructions

3. Proper use

The cordless handheld circular saw is designed for sawing straight cuts in wood, wood-type materials and plastics. In the case of plastic workpieces, be careful not to overheat the tips of the saw blade and melt the plastic.

The equipment is to be used only for its prescribed purpose. Any other use is deemed to be a case of misuse. The user / operator and not the manufacturer will be liable for any damage or injuries of any kind caused as a result of this.

4. Technical data

Motor power supply: 18 V DC
 Idling speed: 4000 min⁻¹
 Cutting depth at 90°: 51 mm
 Cutting depth at 45°: 35 mm
 Saw blade: Ø 136 mm
 Blade holder: Ø 20 mm
 Blade thickness: 1.8 mm
 Weight: 2.9 kg

Danger!

Sound and vibration

Sound and vibration values were measured in accordance with EN 62841.

L_{pA} sound pressure level 89.7 dB(A)
 K_{pA} uncertainty 3 dB
 L_{WA} sound power level 97.7 dB(A)
 K_{WA} uncertainty 3 dB

Wear ear-muffs.

The impact of noise can cause damage to hearing.

Total vibration values (vector sum of three directions) determined in accordance with EN 62841.

Handle

Vibration emission value $a_{h,W} = 2.397 \text{ m/s}^2$
 K uncertainty = 1.5 m/s²

Additional handle

Vibration emission value $a_{h,W} = 2.554 \text{ m/s}^2$
 K uncertainty = 1.5 m/s²

The stated vibration emission levels and stated noise emission values were measured in accord-

ance with a set of standardized criteria and can be used to compare one power tool with another.

The stated vibration emission levels and stated noise emission values can also be used to make an initial assessment of exposure.

Warning:

The vibration and noise emission levels may vary from the level specified during actual use, depending on the way in which the power tool is used, especially the type of workpiece it is used for.

Keep the noise emissions and vibrations to a minimum.

- Only use appliances which are in perfect working order.
- Service and clean the appliance regularly.
- Adapt your working style to suit the appliance.
- Do not overload the appliance.
- Have the appliance serviced whenever necessary.
- Switch the appliance off when it is not in use.

Caution!

Residual risks

Even if you use this electric power tool in accordance with instructions, certain residual risks cannot be ruled out. The following hazards may arise in connection with the equipment's construction and layout:

1. Lung damage if no suitable protective dust mask is used.
2. Damage to hearing if no suitable ear protection is used.
3. Health damage caused by hand-arm vibrations if the equipment is used over a prolonged period or is not properly guided and maintained.

5. Before starting the equipment

Warning!

Always remove the battery pack before making adjustments to the equipment.

5.1 Setting the cutting depth (Figure 2/3)

- Release the handle on the rear of the guard hood for adjusting the cutting depth (4).
- Place the saw foot (6) flat on the surface of the workpiece you wish to saw. Raise the saw until the saw blade (12) is at the required cut-

ting depth (a).

- Refasten the handle for adjusting the cutting depth (4). Check the handle is securely fastened.

5.2 Miter stop (Figure 4/5)

- The preset standard angle between the saw foot (6) and saw blade (12) is 90°. You can adjust this angle to carry out angled cuts.
- Release the locking lever for miter setting (7) on the front of the saw foot.
- You can now adjust the cutting angle to around 50°. Keep an eye on the cutting angle scale (9) as you do so.
- Refasten the locking lever for miter setting (7). Check the handle is securely fastened.

5.3 Extraction of dust and chips (Figure 6)

- Connect a suitable vacuum cleaner to the provided chip extractor connector (14) of your circular saw (vacuum cleaner not included). This will provide excellent dust extraction on the workpiece. The benefits are that you will protect both the equipment and your own health. Your work area will also be cleaner and safer.
- Dust created when working may be dangerous. Refer to the section entitled "Safety instructions".
- Important! The vacuum cleaner you use for the extraction work must be suitable for the workpiece material.
- Check that all the parts are properly connected.

5.4 Parallel stop (Figure 7/8)

- The parallel stop (16) enables you to saw parallel lines.
- Loosen the locking screw for the parallel stop (8) on the soleplate (6).
- To assemble, slide the parallel stop (16) into the guide (c) on the soleplate (6) (see Figure 7).
- Set the required spacing and then tighten the locking screw (8) again.
- Using the parallel stop: Position the parallel stop (16) flat on the edge of the workpiece and start the cut.

Important! Carry out a trial cut in a piece of waste wood

5.5 Line guide (Fig. 9)

Using the line guide (15) you can carry out exact cuts following cutting lines marked on the workpiece.

Use the mark (d) for the 0° or 90° angle setting and the mark (b) for the 45° angle setting.

For information on the angle setting see 5.2

Important! Carry out a trial cut in a piece of waste wood

5.6 Charging the LI battery pack (Fig. 10-11)

1. Remove the battery pack (g) from the handle, pressing the pushlock buttons (f) downwards to do so.
2. Check that your mains voltage is the same as that marked on the rating plate of the battery charger. Insert the power plug of the charger (j) into the mains socket outlet. The green LED will then begin to flash.
3. Push the battery pack onto the battery charger.

In section 10 "Charger indicator" you will find a table with an explanation of the LED indicator on the charger.

Important!

Only use the rechargeable battery and charger when dry and with an ambient temperature of 10-40°C.

Store the rechargeable battery, cordless tool and charger in a dry place with an ambient temperature of: Rechargeable battery = 10-20°C
Cordless tool, charger = 10-40°C.

If the battery pack fails to become charged, please check

- whether there is voltage at the socket-outlet
- whether there is proper contact at the charging contacts on the charger.

If the battery still fails to become charged, please return

- the charger
- the battery pack

to our Customer Service Department.

To ensure that items are properly packaged and delivered when you send them to us, please contact our customer service or the point of sale at which the equipment was purchased.

When shipping or disposing of batteries and cordless tools, always ensure that they are packed individually in plastic bags to prevent short circuits and fires.

To ensure that the battery pack provides long service, you should take care to recharge it promptly. You must recharge the battery pack when you notice that the performance of the device drops. Never allow the battery pack to become fully discharged. This will cause it to develop a defect.

5.7 Battery capacity indicator (Fig. 10 – Item h)

Press the battery capacity indicator switch (i). The battery capacity indicator (h) shows the charge status of the battery using 3 LEDs.

All 3 LEDs are lit:

The battery is fully charged.

2 or 1 LED(s) are lit:

The battery has an adequate remaining charge.

1 LED flashes:

The battery is empty, recharge the battery.

All LEDs blink:

The battery temperature is too low. Remove the battery from the equipment, keep it at room temperature for one day. If the fault reoccurs, this means that the rechargeable battery has undergone exhaustive discharge and is defective. Remove the battery from the equipment. Never use or charge a defective battery.

6. Operation

Warning!

Always remove the battery pack before making adjustments to the equipment.

6.1 Working with the hand-held circular saw

- Always hold the tool firmly by the handles provided (1 and 10) to ensure that you handle it safely when using it.
- The swing guard hood (19) is pushed back automatically by the workpiece.
- Do not use force!
- Push forwards gently and evenly with the circular saw.
- The waste piece should be on the right-hand side of the circular saw so that the wide

section of the support bench supports its full area.

- If you are sawing down a line that has been drawn, guide the circular saw along the corresponding notch.
- Clamp small pieces of wood securely before sawing them. Never hold them with your hand.
- Always follow the safety instructions. Wear safety goggles.
- Do not use defective saw blades or blades that are cracked or broken.
- Do not use any flanges / flange nuts whose bore hole is larger or smaller than those in the saw blade.
- The saw blade must not be decelerated by hand or by applying lateral pressure to the blade.
- Check that the swing guard hood works properly. The swing guard hood must not jam, and it must return to its initial position when you have completed the cut.
- Before you use the circular saw, check the function of the swing guard hood with the mains plug disconnected.
- Before you use the machine, ensure that the safety equipment such as the swing guard hood, flanges and adjustment devices are in working order and are correctly adjusted and secure.
- You can connect a suitable dust extraction system to the sawdust extraction connector (14). Ensure that the dust extractor line is safely and correctly connected.
- The moving swing guard hood must not be fixed in the retracted guard hood when the saw is in use.

6.2 Using the circular saw

- Adjust the cutting depth, cutting angle and parallel stop (see section 5.1, 5.2 and 5.4)
- Do not switch on the circular saw until you have fitted a saw blade.
- Place the saw foot flat on the workpiece you wish to saw. The saw blade must not be in contact with the workpiece.
- Hold the circular saw firmly with both hands.

6.3 Switching ON/OFF (Fig. 12)

To switch on:

Press the locking button (3) and the ON/OFF switch (2) at the same time

- Allow the saw blade to accelerate until it reaches full speed. Then slowly move the saw

blade along the cutting line. Only exert gentle pressure on the saw blade as you do so.

To switch off:

Release the locking button and ON/OFF switch

- If you release the handle the equipment will shut down automatically which means that it cannot operate accidentally.
- Ensure that you do not cover or block the ventilation openings whilst working with the tool.
- Do not slow down the saw blade after you switch it off by pressing it sideways.
- Important! Do not put down the machine until the saw blade has reached a complete standstill.

Important. Carry out a trial cut in a piece of waste wood

6.4 Changing the saw blade (Fig. 13-16)

Warning!

Always remove the battery pack before making adjustments to the equipment.

Use only saw blades which comply with standard EN 847-1 and are of the same type as the saw blade supplied with this circular saw. Ask your dealer for advice.

Warning!

Do not use grinding wheels!

The diameters of the saw blades used must correspond to the diameters specified on the hand-held circular saw blade!

Use only recommended saw blades!

Use the saw blade key (13) supplied to change the saw blade. The saw blade key (13) is stored in the housing. If required, pull the saw blade key (13) out of the housing (see Figure 13).

Important. The hand-held circular saw must not be operated with the saw blade key (13) inserted in it.

- Press the spindle lock (11).
- Undo the screw to secure the saw blade (17) using the saw blade key (13).
- Push back and secure the moving swing guard hood (19) using the lever for the swing guard hood (20).
- Remove the flange (18) and the saw blade (12) in a downwards direction.
- Clean the flange and insert the new saw blade. Pay attention to the running direc-

tion (see arrow on the guard hood and saw blade).

- Tighten the screw to secure the saw blade (17), check it runs true.
- Before you press the On/Off switch, make sure that the saw blade is correctly fitted and that moving parts run smoothly and the clamping screws are tightened securely.

6.5 LED lamp (Fig. 1/Item 5)

The LED lamp (5) can be used in poor lighting conditions to additionally illuminate the cutting position. The LED lamp (5) will come on automatically as soon as you press the locking button for the On/Off switch (3).

7. Cleaning, maintenance and ordering of spare parts

Danger!

Always pull out the battery pack before starting any cleaning work.

7.1 Cleaning

- Keep all safety devices, air vents and the motor housing free of dirt and dust as far as possible. Wipe the equipment with a clean cloth or blow it with compressed air at low pressure.
- We recommend that you clean the device immediately each time you have finished using it.
- Clean the equipment regularly with a moist cloth and some soft soap. Do not use cleaning agents or solvents; these could attack the plastic parts of the equipment. Ensure that no water can seep into the device. The ingress of water into an electric tool increases the risk of an electric shock.

7.2 Maintenance

There are no parts inside the equipment which require additional maintenance.

7.3 Ordering replacement parts:

Please quote the following data when ordering replacement parts:

- Type of machine
 - Article number of the machine
 - Identification number of the machine
 - Replacement part number of the part required
- For our latest prices and information please go to www.Einhell-Service.com

8. Disposal and recycling

The equipment is supplied in packaging to prevent it from being damaged in transit. The raw materials in this packaging can be reused or recycled. The equipment and its accessories are made of various types of material, such as metal and plastic. **Never place defective equipment in your household refuse. The equipment should be taken to a suitable collection center for proper disposal. If you do not know the whereabouts of such a collection point, you should ask in your local council offices.**

9. Storage

Store the equipment and accessories in a dark and dry place at above freezing temperature. The ideal storage temperature is between 10 and 40 °C. Store the electric tool in its original packaging.



МАГАЗИН
БАШ МАЙСТОРА®
ПРОФЕСИОНАЛНИ РЕШЕНИЯ

10. Charger indicator

Indicator status		Explanations and actions
Red LED	Green LED	
Off	Flashing	<p>Ready for use The charger is connected to the mains and is ready for use; there is no battery pack in the charger </p>
On	Off	<p>Charging The charger is charging the battery pack in quick charge mode. The charging times are shown directly on the charger. Important! The actual charging times may vary slightly from the stated charging times depending on the existing battery charge.</p>
Off	On	<p>The battery is charged and ready for use. (READY TO GO) The unit then changes over to gentle charging mode until the battery is fully charged. To do this, leave the rechargeable battery on the charger for approx. 15 minutes longer. Action: Take the battery pack out of the charger. Disconnect the charger from the mains supply.</p>
Flashing	Off	<p>Adapted charging For safety reasons the charging is performed less quickly and takes more time. The reasons can be: - The battery pack has not been used for a very long time or an already flat battery was further discharged (exhaustive discharge). - The battery pack temperature is outside the ideal range (between 10° C and 40 °C). Action: Wait for the charging to be completed; you can still continue to charge the battery pack.</p>
Flashing	Flashing	<p>Fault Charging is no longer possible. The battery pack is defective. Action: Never charge a defective battery pack. Take the battery pack out of the charger.</p>
On	On	<p>Temperature fault The battery pack is too hot (e.g. due to direct sunshine) or too cold (below 0° C). Action: Remove the battery pack and keep it at room temperature (approx. 20° C) for one day .</p>

Disposal

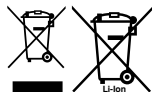

Power tools, rechargeable batteries, accessories and packaging should be sorted for environmental-friendly recycling.

Do not dispose of power tools and batteries/rechargeable batteries into household waste! ☺

Only for EU countries:

According to the Directive 2012/19/EU on waste electrical and electronic equipment and its transposition into national law, power tools that are no longer usable, and, according to the Directive 2006/66/EC, defective or drained batteries must be collected separately and disposed of in an environmentally correct manner.

If disposed incorrectly, waste electrical and electronic equipment may have harmful effects on the environment and human health, due to the potential presence of hazardous substances.

Only for United Kingdom:

According to The Waste Electrical and Electronic Equipment Regulations 2013 (SI 2013/3113) (as amended) and the Waste Batteries and Accumulators Regulations 2009 (SI 2009/890) (as amended), products that are no longer usable must be collected separately and disposed of in an environmentally friendly manner.

The reprinting or reproduction by any other means, in whole or in part, of documentation and papers accompanying products is permitted only with the express consent of the Einhell Germany AG.

Subject to technical changes



Service information

We have competent service partners in all countries named on the guarantee certificate whose contact details can also be found on the guarantee certificate. These partners will help you with all service requests such as repairs, spare and wearing part orders or the purchase of consumables.

Please note that the following parts of this product are subject to normal or natural wear and that the following parts are therefore also required for use as consumables. 

Category	Example
Wear parts*	Battery
Consumables*	Saw blade
Missing parts	

* Not necessarily included in the scope of delivery!

In the effect of defects or faults, please register the problem on the internet at www.Einhell-Service.com. Please ensure that you provide a precise description of the problem and answer the following questions in all cases:

- Did the equipment work at all or was it defective from the beginning?
- Did you notice anything (symptom or defect) prior to the failure?
- What malfunction does the equipment have in your opinion (main symptom)? Describe this malfunction.

