

INSTRUCTION MANUAL

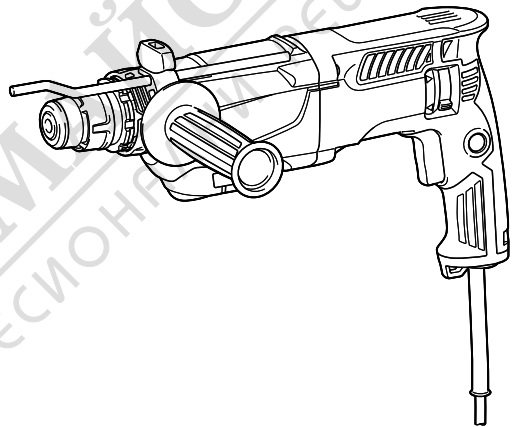

# Combination Hammer

## M8701



DOUBLE INSULATION



Read before use.



# SPECIFICATIONS

<b>Model:</b>		<b>M8701</b>
Drilling capacities	Concrete	26 mm
	Core bit	68 mm
	Diamond core bit (dry type)	80 mm
	Steel	13 mm
	Wood	32 mm
No load speed		0 - 1,200 min <sup>-1</sup>
Blows per minute		0 - 4,500 min <sup>-1</sup>
Overall length		362 mm
Net weight		2.7 kg
Safety class		□/II

- Due to our continuing program of research and development, the specifications herein are subject to change without notice.
- Specifications may differ from country to country.
- Weight according to EPTA-Procedure 01/2003

## Symbols

The following show the symbols used for the equipment. Be sure that you understand their meaning before use.

	Read instruction manual.
	DOUBLE INSULATION
	Only for EU countries Do not dispose of electric equipment together with household waste material! In observance of the European Directive, on Waste Electric and Electronic Equipment and its implementation in accordance with national law, electric equipment that have reached the end of their life must be collected separately and returned to an environmentally compatible recycling facility.

## Intended use

The tool is intended for hammer drilling and drilling in brick, concrete and stone as well as for chiselling work. It is also suitable for drilling without impact in wood, metal, ceramic and plastic.

## Power supply

The tool should be connected only to a power supply of the same voltage as indicated on the nameplate, and can only be operated on single-phase AC supply. They are double-insulated and can, therefore, also be used from sockets without earth wire.

## Noise

The typical A-weighted noise level determined according to EN60745:

Sound pressure level ( $L_{pA}$ ): 90 dB(A)

Sound power level ( $L_{WA}$ ): 101 dB (A)

Uncertainty (K): 3 dB(A)

**⚠ WARNING: Wear ear protection.**

## Vibration

The vibration total value (tri-axial vector sum) determined according to EN60745:

Work mode: hammer drilling into concrete

Vibration emission ( $a_{h,HD}$ ): 16.5 m/s<sup>2</sup>

Uncertainty (K): 1.5 m/s<sup>2</sup>

Work mode: chiselling function with side grip

Vibration emission ( $a_{h,CHRG}$ ): 9.0 m/s<sup>2</sup>

Uncertainty (K): 1.5 m/s<sup>2</sup>

Work mode: drilling into metal

Vibration emission ( $a_{h,D}$ ): 2.5 m/s<sup>2</sup> or less

Uncertainty (K): 1.5 m/s<sup>2</sup>

**NOTE:** The declared vibration emission value has been measured in accordance with the standard test method and may be used for comparing one tool with another.

**NOTE:** The declared vibration emission value may also be used in a preliminary assessment of exposure.

**⚠ WARNING:** The vibration emission during actual use of the power tool can differ from the declared emission value depending on the ways in which the tool is used.

**⚠ WARNING:** Be sure to identify safety measures to protect the operator that are based on an estimation of exposure in the actual conditions of use (taking account of all parts of the operating cycle such as the times when the tool is switched off and when it is running idle in addition to the trigger time).

## EC Declaration of Conformity

**For European countries only**

The EC declaration of conformity is included as Annex A to this instruction manual.

# SAFETY WARNINGS

## General power tool safety warnings

**⚠ WARNING:** Read all safety warnings and all instructions. Failure to follow the warnings and instructions may result in electric shock, fire and/or serious injury.

### Save all warnings and instructions for future reference.

The term "power tool" in the warnings refers to your mains-operated (corded) power tool or battery-operated (cordless) power tool.

#### Work area safety

1. **Keep work area clean and well lit.** Cluttered or dark areas invite accidents.
2. **Do not operate power tools in explosive atmospheres, such as in the presence of flammable liquids, gases or dust.** Power tools create sparks which may ignite the dust or fumes.
3. **Keep children and bystanders away while operating a power tool.** Distractions can cause you to lose control.

#### Electrical Safety

1. **Power tool plugs must match the outlet. Never modify the plug in any way. Do not use any adapter plugs with earthed (grounded) power tools.** Unmodified plugs and matching outlets will reduce risk of electric shock.
2. **Avoid body contact with earthed or grounded surfaces such as pipes, radiators, ranges and refrigerators.** There is an increased risk of electric shock if your body is earthed or grounded.
3. **Do not expose power tools to rain or wet conditions.** Water entering a power tool will increase the risk of electric shock.
4. **Do not abuse the cord. Never use the cord for carrying, pulling or unplugging the power tool. Keep cord away from heat, oil, sharp edges or moving parts.** Damaged or entangled cords increase the risk of electric shock.
5. **When operating a power tool outdoors, use an extension cord suitable for outdoor use.** Use of a cord suitable for outdoor use reduces the risk of electric shock.
6. **If operating a power tool in a damp location is unavoidable, use a residual current device (RCD) protected supply.** Use of an RCD reduces the risk of electric shock.
7. **Use of power supply via an RCD with a rated residual current of 30 mA or less is always recommended.**

#### Personal Safety

1. **Stay alert, watch what you are doing and use common sense when operating a power tool. Do not use a power tool while you are tired or under the influence of drugs, alcohol or medication.** A moment of inattention while operating power tools may result in serious personal injury.

2. **Use personal protective equipment. Always wear eye protection.** Protective equipment such as dust mask, non-skid safety shoes, hard hat, or hearing protection used for appropriate conditions will reduce personal injuries.
3. **Prevent unintentional starting. Ensure the switch is in the off-position before connecting to power source and/or battery pack, picking up or carrying the tool.** Carrying power tools with your finger on the switch or energising power tools that have the switch on invites accidents.
4. **Remove any adjusting key or wrench before turning the power tool on.** A wrench or a key left attached to a rotating part of the power tool may result in personal injury.
5. **Do not overreach. Keep proper footing and balance at all times.** This enables better control of the power tool in unexpected situations.
6. **Dress properly. Do not wear loose clothing or jewellery. Keep your hair, clothing, and gloves away from moving parts.** Loose clothes, jewellery or long hair can be caught in moving parts.
7. **If devices are provided for the connection of dust extraction and collection facilities, ensure these are connected and properly used.** Use of dust collection can reduce dust-related hazards.

#### Power tool use and care

1. **Do not force the power tool. Use the correct power tool for your application.** The correct power tool will do the job better and safer at the rate for which it was designed.
2. **Do not use the power tool if the switch does not turn it on and off.** Any power tool that cannot be controlled with the switch is dangerous and must be repaired.
3. **Disconnect the plug from the power source and/or the battery pack from the power tool before making any adjustments, changing accessories, or storing power tools.** Such preventive safety measures reduce the risk of starting the power tool accidentally.
4. **Store idle power tools out of the reach of children and do not allow persons unfamiliar with the power tool or these instructions to operate the power tool.** Power tools are dangerous in the hands of untrained users.
5. **Maintain power tools. Check for misalignment or binding of moving parts, breakage of parts and any other condition that may affect the power tool's operation. If damaged, have the power tool repaired before use.** Many accidents are caused by poorly maintained power tools.
6. **Keep cutting tools sharp and clean.** Properly maintained cutting tools with sharp cutting edges are less likely to bind and are easier to control.
7. **Use the power tool, accessories and tool bits etc. in accordance with these instructions, taking into account the working conditions and the work to be performed.** Use of the power tool for operations different from those intended could result in a hazardous situation.

## Service

1. Have your power tool serviced by a qualified repair person using only identical replacement parts. This will ensure that the safety of the power tool is maintained.
2. Follow instruction for lubricating and changing accessories.
3. Keep handles dry, clean and free from oil and grease.

## ROTARY HAMMER SAFETY WARNINGS

1. Wear ear protectors. Exposure to noise can cause hearing loss.
2. Use auxiliary handle(s), if supplied with the tool. Loss of control can cause personal injury.
3. Hold power tool by insulated gripping surfaces, when performing an operation where the cutting accessory may contact hidden wiring or its own cord. Cutting accessory contacting a "live" wire may make exposed metal parts of the power tool "live" and could give the operator an electric shock.
4. Wear a hard hat (safety helmet), safety glasses and/or face shield. Ordinary eye or sun glasses are NOT safety glasses. It is also highly recommended that you wear a dust mask and thickly padded gloves.
5. Be sure the bit is secured in place before operation.
6. Under normal operation, the tool is designed to produce vibration. The screws can come loose easily, causing a breakdown or accident. Check tightness of screws carefully before operation.
7. In cold weather or when the tool has not been used for a long time, let the tool warm up for a while by operating it under no load. This will loosen up the lubrication. Without proper warm-up, hammering operation is difficult.
8. Always be sure you have a firm footing. Be sure no one is below when using the tool in high locations.
9. Hold the tool firmly with both hands.
10. Keep hands away from moving parts.
11. Do not leave the tool running. Operate the tool only when hand-held.
12. Do not point the tool at any one in the area when operating. The bit could fly out and injure someone seriously.
13. Do not touch the bit or parts close to the bit immediately after operation; they may be extremely hot and could burn your skin.
14. Some material contains chemicals which may be toxic. Take caution to prevent dust inhalation and skin contact. Follow material supplier safety data.

## SAVE THESE INSTRUCTIONS.

**⚠WARNING:** DO NOT let comfort or familiarity with product (gained from repeated use) replace strict adherence to safety rules for the subject product. MISUSE or failure to follow the safety rules stated in this instruction manual may cause serious personal injury.

## FUNCTIONAL DESCRIPTION

**⚠CAUTION:** Always be sure that the tool is switched off and unplugged before adjusting or checking function on the tool.

### Switch action

**⚠CAUTION:** Before plugging in the tool, always check to see that the switch trigger actuates properly and returns to the "OFF" position when released.

**⚠CAUTION:** Switch can be locked in "ON" position for ease of operator comfort during extended use. Apply caution when locking tool in "ON" position and maintain firm grasp on tool.

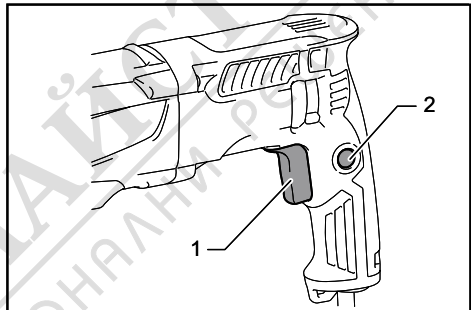

► 1. Switch trigger 2. Lock button

To start the tool, simply pull the switch trigger. Tool speed is increased by increasing pressure on the switch trigger. Release the switch trigger to stop.

For continuous operation, pull the switch trigger, push in the lock button and then release the switch trigger. To stop the tool from the locked position, pull the switch trigger fully, then release it.

### Reversing switch action

**⚠CAUTION:** Always check the direction of rotation before operation.

**NOTICE:** Use the reversing switch only after the tool comes to a complete stop. Changing the direction of rotation before the tool stops may damage the tool.

**NOTICE:** If the switch trigger can not be depressed, check to see that the reversing switch is fully set to position ◁ (A side) or ▷ (B side).

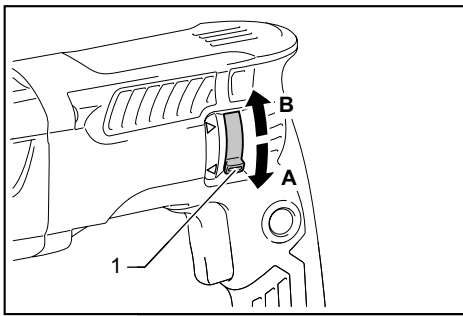

► 1. Reversing switch lever

This tool has a reversing switch to change the direction of rotation. Move the reversing switch lever to the position ◀ (A side) for clockwise rotation or to the position ▶ (B side) for counterclockwise rotation.

### Selecting the action mode

**NOTICE:** Do not rotate the action mode changing knob when the tool is running. The tool will be damaged.

**NOTICE:** To avoid rapid wear on the mode change mechanism, be sure that the action mode changing knob is always positively located in one of the three action mode positions.

### Rotation with hammering

For drilling in concrete, masonry, etc., rotate the action mode changing knob to the  symbol. Use a tungsten carbide tipped bit (optional accessory).

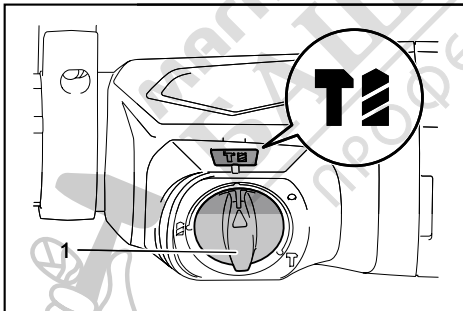

► 1. Action mode changing knob

### Rotation only

For drilling in wood, metal or plastic materials, rotate the action mode changing knob to the  symbol. Use a twist drill bit or wood drill bit.

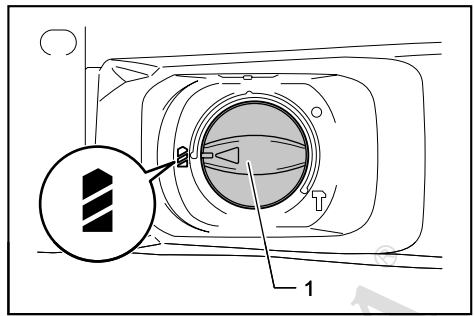

► 1. Action mode changing knob

### Hammering only

For chipping, scaling or demolition operations, rotate the action mode changing knob to the  symbol. Use a bull point, cold chisel, scaling chisel, etc.

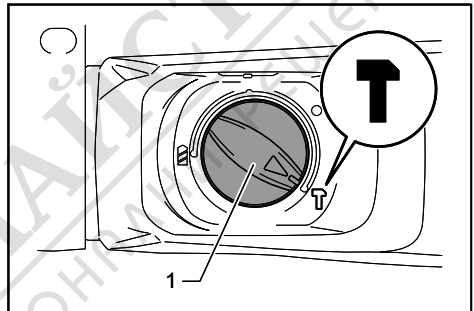

► 1. Action mode changing knob

### Torque limiter

**NOTICE:** As soon as the torque limiter actuates, switch off the tool immediately. This will help prevent premature wear of the tool.

**NOTICE:** Drill bits such as hole saw, which tend to pinch or catch easily in the hole, are not appropriate for this tool. This is because they will cause the torque limiter to actuate too frequently.

The torque limiter will actuate when a certain torque level is reached. The motor will disengage from the output shaft. When this happens, the drill bit will stop turning.

## ASSEMBLY

**CAUTION:** Always be sure that the tool is switched off and unplugged before carrying out any work on the tool.

## Side grip (auxiliary handle)

**CAUTION:** Always use the side grip to ensure safe operation.

**CAUTION:** After installing or adjusting the side grip, make sure that the side grip is firmly secured.

Install the side grip so that the protrusions on the grip fit in between the grooves on the tool barrel. Then tighten the thumb screw clockwise to fix the grip at the desired position.

The side grip can be swung 360° so as to be secured at any position.

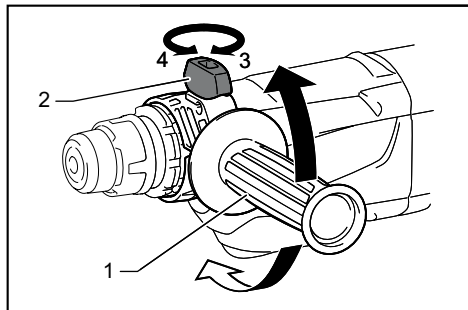

► 1. Side grip 2. Thumb screw 3. Tighten 4. Loosen

## Grease

Coat the shank end of the drill bit/chisel beforehand with a small amount of grease (about 0.5 - 1 g). This chuck lubrication assures smooth action and longer service life.

## Installing or removing drill bit/chisel

Clean the shank end of the drill bit/chisel and apply grease before installing the drill bit/chisel.

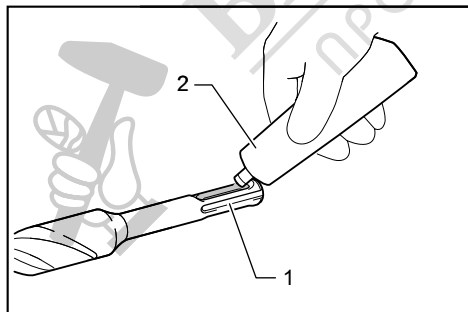

► 1. Shank end of the drill bit/chisel 2. Grease

Insert the drill bit/chisel into the tool. Turn the drill bit/chisel and push it in until it engages. After installing the drill bit/chisel, always make sure that the drill bit/chisel is securely held in place by trying to pull it out.

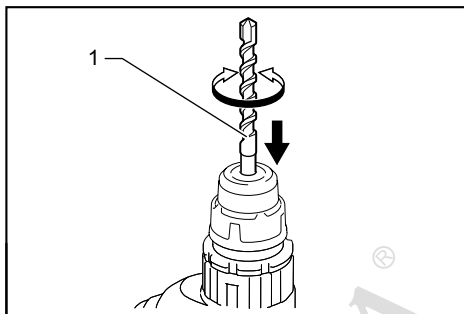

► 1. Drill bit/chisel

To remove the drill bit/chisel, pull the chuck cover down all the way and pull the drill bit/chisel out.

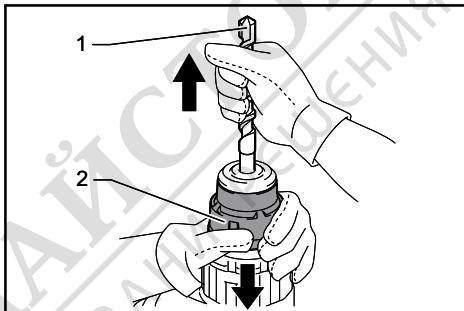

► 1. Drill bit/chisel 2. Chuck cover

## Chisel angle (when chipping, scaling or demolishing)

The chisel can be secured at the desired angle. To change the chisel angle, rotate the action mode changing knob to the O symbol. Turn the chisel to the desired angle.

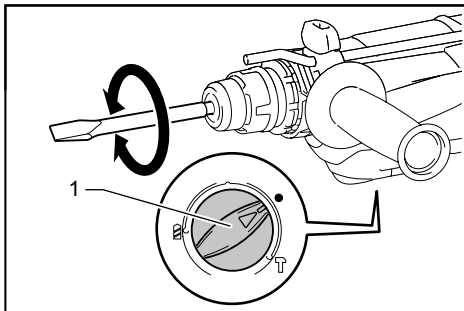

► 1. Action mode changing knob

Rotate the action mode changing knob to the  $\text{T}$  symbol. Then make sure that the chisel is securely held in place by turning it slightly.

## Depth gauge

The depth gauge is convenient for drilling holes of uniform depth. Loosen the thumb screw and adjust the depth gauge to the desired depth. After adjusting, tighten the thumb screw firmly.

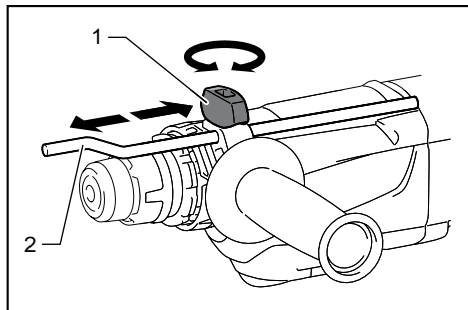

► 1. Thumb screw 2. Depth gauge

**NOTE:** The depth gauge cannot be used at the position where the depth gauge touches against the gear housing/motor housing.

## OPERATION

**CAUTION:** Always use the side grip (auxiliary handle) and firmly hold the tool by both side grip and switch handle during operations.

**CAUTION:** Always make sure that the workpiece is secured before operation.

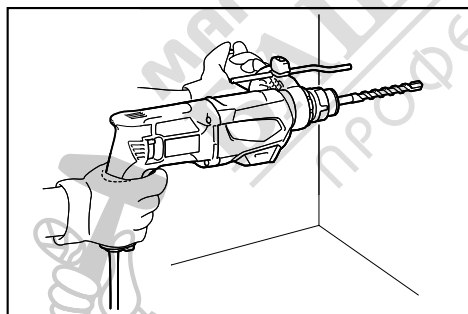

## Hammer drilling operation

**CAUTION:** There is tremendous and sudden twisting force exerted on the tool/drill bit at the time of hole break-through, when the hole becomes clogged with chips and particles, or when striking reinforcing rods embedded in the concrete. **Always use the side grip (auxiliary handle) and firmly hold the tool by both side grip and switch handle during operations.** Failure to do so may result in the loss of control of the tool and potentially severe injury.

Set the action mode changing knob to the  symbol. Position the drill bit at the desired location for the hole, then pull the switch trigger. Do not force the tool. Light pressure gives best results. Keep the tool in position and prevent it from slipping away from the hole.

Do not apply more pressure when the hole becomes clogged with chips or particles. Instead, run the tool at an idle, then remove the drill bit partially from the hole. By repeating this several times, the hole will be cleaned out and normal drilling may be resumed.

**NOTE:** Eccentricity in the drill bit rotation may occur while operating the tool with no load. The tool automatically centers itself during operation. This does not affect the drilling precision.

## Chipping/Scaling/Demolition

Set the action mode changing knob to the  symbol. Hold the tool firmly with both hands. Turn the tool on and apply slight pressure on the tool so that the tool will not bounce around, uncontrolled. Pressing very hard on the tool will not increase the efficiency.

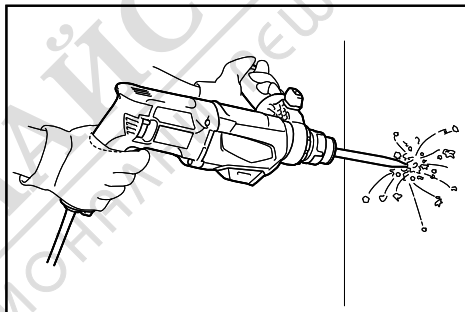

## Drilling in wood or metal

**CAUTION:** Hold the tool firmly and exert care when the drill bit begins to break through the workpiece. There is a tremendous force exerted on the tool/drill bit at the time of hole break through.

**CAUTION:** A stuck drill bit can be removed simply by setting the reversing switch to reverse rotation in order to back out. However, the tool may back out abruptly if you do not hold it firmly.

**CAUTION:** Always secure workpieces in a vise or similar hold-down device.

**NOTICE:** Never use "rotation with hammering" when the drill chuck is installed on the tool. The drill chuck may be damaged. Also, the drill chuck will come off when reversing the tool.

**NOTICE:** Pressing excessively on the tool will not speed up the drilling. In fact, this excessive pressure will only serve to damage the tip of your drill bit, decrease the tool performance and shorten the service life of the tool.

Set the action mode changing knob to the  symbol. You can drill up to 13 mm (1/2") diameter in metal and up to 32 mm (1-1/4") diameter in wood.

Use a drill chuck assembly (optional accessory). When installing it, refer to the section "Installing or removing drill bit/chisel".

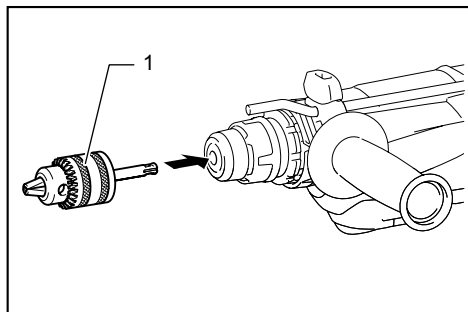

► 1. Drill chuck assembly (optional accessory)

To install the drill bit, place it in the chuck as far as it will go. Tighten the chuck by hand. Place the chuck key in each of the three holes and tighten clockwise. Be sure to tighten all three chuck holes evenly.

To remove the drill bit, turn the chuck key counterclockwise in just one hole, then loosen the chuck by hand.

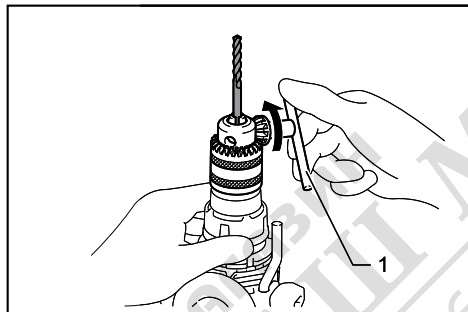

► 1. Chuck key

## Diamond core drilling

**NOTICE:** If performing diamond core drilling operations using "rotation with hammering" action, the diamond core bit may be damaged.

When performing diamond core drilling operations, always set the change lever to the  position to use "rotation only" action.

## MAINTENANCE

**CAUTION:** Always be sure that the tool is switched off and unplugged before attempting to perform inspection or maintenance.

**NOTICE:** Never use gasoline, benzine, thinner, alcohol or the like. Discoloration, deformation or cracks may result.

To maintain product SAFETY and RELIABILITY, repairs, carbon brush inspection and replacement, any other maintenance or adjustment should be performed by Makita Authorized or Factory Service Centers, always using Makita replacement parts.



Makita Europe N.V. Jan-Baptist Vinkstraat 2,  
3070 Kortenberg, Belgium

Makita Corporation 3-11-8, Sumiyoshi-cho,  
Anjo, Aichi 446-8502 Japan

[www.makita.com](http://www.makita.com)

885528-223  
EN  
20160530