

DEWALT®

XR LI-ION

МАГАЗИН
БАШ МАЙСТЕР

ПРОФЕСИОНАЛНИ РЕШЕНИЯ



www.DEWALT.com

DCR029



МАГАЗИН
БАШ МАЙСТОРА[®]
ПРОФЕСИОНАЛНИ РЕШЕНИЯ

Fig. A

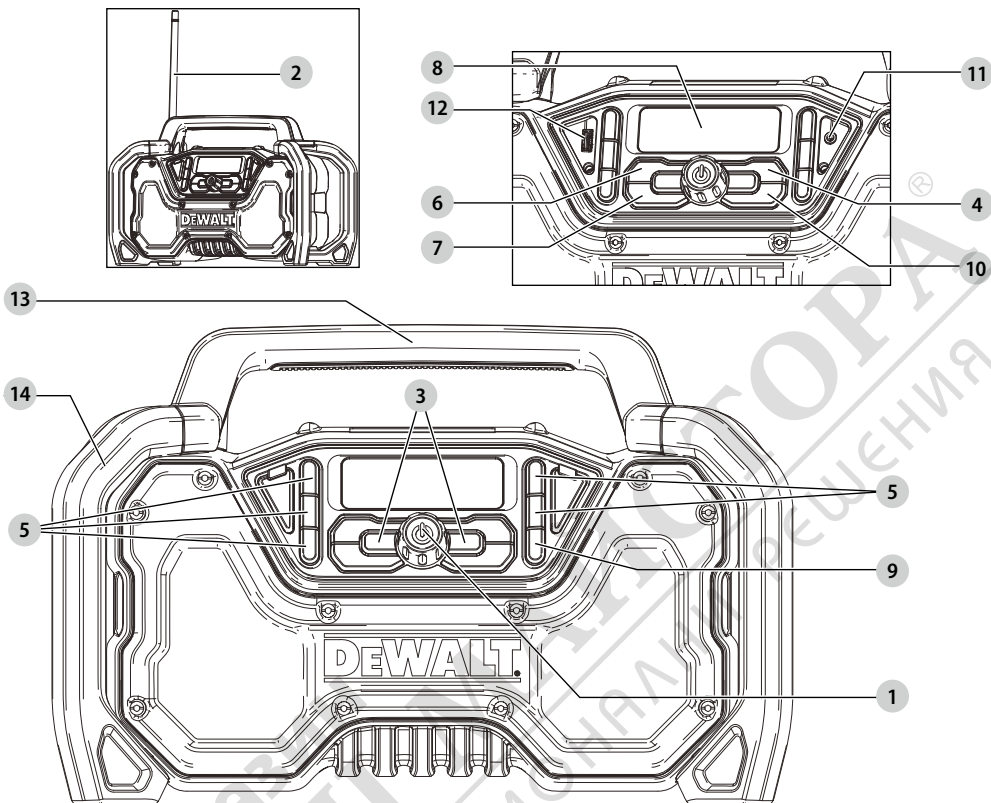
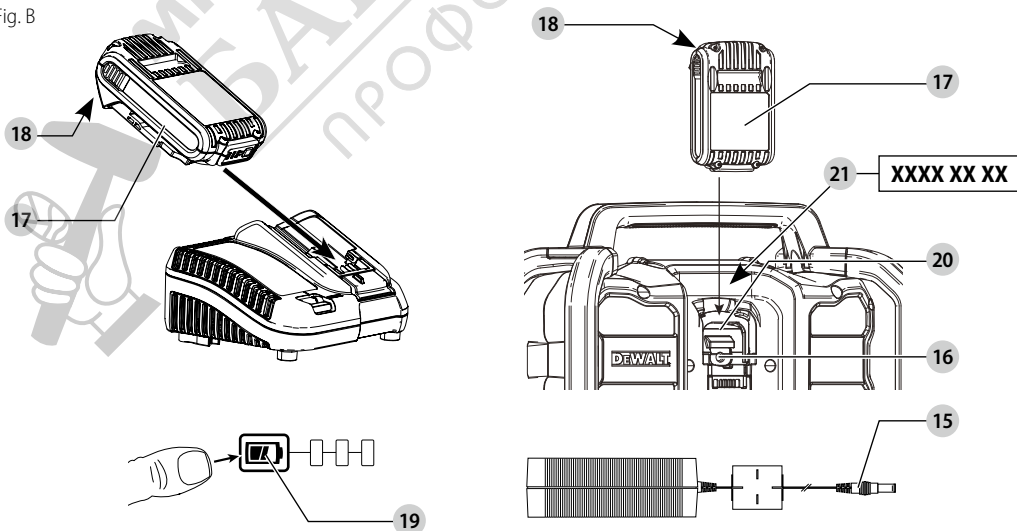

Fig. B



RADIO

DCR029

Congratulations!

You have chosen a DEWALT tool. Years of experience, thorough product development and innovation make DEWALT one of the most reliable partners for professional power tool users.

Technical Data

	DCR029	
Type		1
Input (AC adapter output)	V _{DC}	24
Battery type		Li-Ion
Input (Battery)	V _{DC}	12/18
Weight (without battery pack)	kg	3.53
Max. operating temperature	°C	40
AC Adapter		
Input voltage	V _{AC}	220–240
Input AC frequency	Hz	50–60
Output voltage	V _{DC}	24
Output current	A	1.875
Output power	W	45
Average active efficiency	%	88.5
Efficiency at low load (10%)	%	84.3
No-load power consumption	W	< 0.1

EU-Declaration of Conformity

Radio Equipment Directive



Radio DCR029

DEWALT hereby declares that the DEWALT Radio DCR029 is in compliance with the Directive 2014/53/EU and to all applicable EU directive requirements.

The full text of the EU declaration of conformity can be requested at DEWALT, Richard-Klinger-Straße 11, D-65510, Idstein, Germany or is available at the following internet address: www.2helpu.com Search by the Product and Type Number indicated on the nameplate.



WARNING: To reduce the risk of injury, read the instruction manual.

Definitions: Safety Guidelines

The definitions below describe the level of severity for each signal word. Please read the manual and pay attention to these symbols.



DANGER: Indicates an imminently hazardous situation which, if not avoided, **will** result in **death or serious injury**.



WARNING: Indicates a potentially hazardous situation which, if not avoided, **could** result in **death or serious injury**.



CAUTION: Indicates a potentially hazardous situation which, if not avoided, **may** result in **minor or moderate injury**.

NOTICE: Indicates a practice **not related to personal injury** which, if not avoided, **may** result in **property damage**.



Denotes risk of electric shock.



Denotes risk of fire.

Safety Instructions for Radios

- **Do not abuse cord.** Never carry the radio by its cord. Never pull the cord to disconnect from the socket. Keep the cord away from heat, oil and sharp edges.
- **Remove the battery pack.** Switch off before leaving it unattended. Remove the battery pack when not in use, before changing accessories or attachments and before servicing.
- This appliance is intended to be used in moderate climates.
- This appliance is not intended for use by persons (including children) with reduced physical, sensory or mental capabilities, or lack of experience and knowledge, unless they have been given supervision or instruction concerning use of the appliance by a person responsible for their safety.
- Socket and extension cord must have an operative protective conductor.
- **When operating the radio in damp environments is unavoidable, use a residual current device (RCD).** The use of a residual current device (RCD) reduces the risk of electric shock.
- Children should be supervised to ensure that they do not play with the appliance.
- Radio shall not be exposed to dripping or splashing; no objects filled with liquids, such as vases, shall be placed on it.
- No exposed flame sources, such as lighted candles, should be placed on the radio.
- Mains plug is used as the disconnect device; the disconnect device (plug) shall remain readily operable.
- Do not operate the apparatus with a damaged cord or plug.

SAVE THESE INSTRUCTIONS

Chargers

DEWALT chargers require no adjustment and are designed to be as easy as possible to operate.

Electrical Safety

Always check that the battery pack voltage corresponds to the voltage on the rating plate. Also make sure that the voltage of your charger corresponds to that of your mains.

Batteries				Chargers/Charge Times (Minutes)							
Cat #	V _{DC}	Ah	Weight (kg)	DCB104	DCB107	DCB112	DCB113	DCB115	DCB118	DCB132	DCB119
DCB546	18/54	6.0/2.0	1.05	60	270	170	140	90	60	90	X
DCB547	18/54	9.0/3.0	1.46	75*	420	270	220	135*	75*	135*	X
DCB548	18/54	12.0/4.0	1.44	120	540	350	300	180	120	180	X
DCB181	18	1.5	0.35	22	70	45	35	22	22	22	45
DCB182	18	4.0	0.61	60/40**	185	120	100	60	60/40**	60	120
DCB183/B	18	2.0	0.40	30	90	60	50	30	30	30	60
DCB184/B	18	5.0	0.62	75/50**	240	150	120	75	75/50**	75	150
DCB185	18	1.3	0.35	22	60	40	30	22	22	22	X
DCB187	18	3.0	0.54	45	140	90	70	45	45	45	90
DCB189	18	4.0	0.54	60	185	120	100	60	60	60	120
DCB122	12	2.0	0.22	30	90	60	50	30	X	30	60
DCB124	12	3.0	0.25	45	140	90	70	45	45	45	90
DCB125	12	1.3	0.20	22	60	40	30	22	X	22	40
DCB127	12	2.0	0.20	30	90	60	50	30	X	30	60

*Date code 201811475B or later

**Date code 201536 or later



Your DEWALT charger is double insulated in accordance with EN60335; therefore no earth wire is required.

If the supply cord is damaged, it must be replaced by a specially prepared cord available through the DEWALT service organisation.

Mains Plug Replacement (U.K. & Ireland Only)

If a new mains plug needs to be fitted:

- Safely dispose of the old plug.
- Connect the brown lead to the live terminal in the plug.
- Connect the blue lead to the neutral terminal.



WARNING: No connection is to be made to the earth terminal.

Follow the fitting instructions supplied with good quality plugs. Recommended fuse: 3 A.

Using an Extension Cable

An extension cord should not be used unless absolutely necessary. Use an approved extension cable suitable for the power input of your charger (see **Technical Data**). The minimum conductor size is 1 mm²; the maximum length is 30 m.

When using a cable reel, always unwind the cable completely.

Important Safety Instructions for All Battery Chargers

SAVE THESE INSTRUCTIONS: This manual contains important safety and operating instructions for compatible battery chargers (refer to **Technical Data**).

- Before using charger, read all instructions and cautionary markings on charger, battery pack, and product using battery pack.



WARNING: Shock hazard. Do not allow any liquid to get inside charger. Electric shock may result.



WARNING: We recommend the use of a residual current device with a residual current rating of 30mA or less.



CAUTION: Burn hazard. To reduce the risk of injury, charge only DEWALT rechargeable batteries. Other types of batteries may burst causing personal injury and damage.



CAUTION: Children should be supervised to ensure that they do not play with the appliance.

NOTICE: Under certain conditions, with the charger plugged into the power supply, the exposed charging contacts inside the charger can be shorted by foreign material. Foreign materials of a conductive nature such as, but not limited to, steel wool, aluminum foil or any buildup of metallic particles should be kept away from charger cavities. Always unplug the charger from the power supply when there is no battery pack in the cavity. Unplug charger before attempting to clean

- **DO NOT attempt to charge the battery pack with any chargers other than the ones in this manual.** The charger and battery pack are specifically designed to work together.
- **These chargers are not intended for any uses other than charging DEWALT rechargeable batteries.** Any other uses may result in risk of fire, electric shock or electrocution.
- **Do not expose charger to rain or snow.**
- **Pull by plug rather than cord when disconnecting charger.** This will reduce risk of damage to electric plug and cord.
- **Make sure that cord is located so that it will not be stepped on, tripped over, or otherwise subjected to damage or stress.**
- **Do not use an extension cord unless it is absolutely necessary.** Use of improper extension cord could result in risk of fire, electric shock, or electrocution.

- **Do not place any object on top of charger or place the charger on a soft surface that might block the ventilation slots and result in excessive internal heat.** Place the charger in a position away from any heat source. The charger is ventilated through slots in the top and the bottom of the housing.
- **Do not operate charger with damaged cord or plug—** have them replaced immediately.
- **Do not operate charger if it has received a sharp blow, been dropped, or otherwise damaged in any way.** Take it to an authorised service centre.
- **Do not disassemble charger; take it to an authorised service centre when service or repair is required.** Incorrect reassembly may result in a risk of electric shock, electrocution or fire.
- In case of damaged power supply cord the supply cord must be replaced immediately by the manufacturer, its service agent or similar qualified person to prevent any hazard.
- **Disconnect the charger from the outlet before attempting any cleaning. This will reduce the risk of electric shock.** Removing the battery pack will not reduce this risk.
- **NEVER** attempt to connect two chargers together.
- **The charger is designed to operate on standard 230V household electrical power. Do not attempt to use it on any other voltage.** This does not apply to the vehicular charger.







Charging a Battery (Fig. B)

1. Plug the charger into an appropriate outlet before inserting battery pack.
2. Insert the battery pack **17** into the charger, making sure the battery pack is fully seated in the charger. The red (charging) light will blink repeatedly indicating that the charging process has started.
3. The completion of charge will be indicated by the red light remaining ON continuously. The battery pack is fully charged and may be used at this time or left in the charger. To remove the battery pack from the charger, push the battery release button **18** on the battery pack.

NOTE: To ensure maximum performance and life of lithium-ion battery packs, charge the battery pack fully before first use.

Charger Operation

Refer to the indicators below for the charge status of the battery pack.

Charge Indicators	
 Charging	
 Fully Charged	
 Hot/Cold Pack Delay*	

*The red light will continue to blink, but a yellow indicator light will be illuminated during this operation. Once the battery pack has reached an appropriate temperature, the yellow light will turn off and the charger will resume the charging procedure.

The compatible charger(s) will not charge a faulty battery pack. The charger will indicate faulty battery by refusing to light.

NOTE: This could also mean a problem with a charger.

If the charger indicates a problem, take the charger and battery pack to be tested at an authorised service centre.

Hot/Cold Pack Delay

When the charger detects a battery pack that is too hot or too cold, it automatically starts a Hot/Cold Pack Delay, suspending charging until the battery pack has reached an appropriate temperature. The charger then automatically switches to the pack charging mode. This feature ensures maximum battery pack life.

A cold battery pack will charge at a slower rate than a warm battery pack. The battery pack will charge at that slower rate throughout the entire charging cycle and will not return to maximum charge rate even if the battery pack warms.

The DCB118 charger is equipped with an internal fan designed to cool the battery pack. The fan will turn on automatically when the battery pack needs to be cooled. Never operate the charger if the fan does not operate properly or if ventilation slots are blocked. Do not permit foreign objects to enter the interior of the charger.

Electronic Protection System

XR Li-Ion tools are designed with an Electronic Protection System that will protect the battery pack against overloading, overheating or deep discharge.

The tool will automatically turn off if the Electronic Protection System engages. If this occurs, place the lithium-ion battery pack on the charger until it is fully charged.

Wall Mounting

These chargers are designed to be wall mountable or to sit upright on a table or work surface. If wall mounting, locate the charger within reach of an electrical outlet, and away from a corner or other obstructions which may impede air flow. Use the back of the charger as a template for the location of the mounting screws on the wall. Mount the charger securely using drywall screws (purchased separately) at least 25.4 mm long with a screw head diameter of 7–9 mm, screwed into wood to an optimal depth leaving approximately 5.5 mm of the screw exposed. Align the slots on the back of the charger with the exposed screws and fully engage them in the slots.

Charger Cleaning Instructions

⚠ WARNING: Shock hazard. Disconnect the charger from the AC outlet before cleaning. Dirt and grease may be removed from the exterior of the charger using a cloth or soft non-metallic brush. Do not use water or any cleaning solutions. Never let any liquid get inside the tool; never immerse any part of the tool into a liquid.

Battery Packs

Important Safety Instructions for All Battery Packs

When ordering replacement battery packs, be sure to include catalogue number and voltage.

The battery pack is not fully charged out of the carton. Before using the battery pack and charger, read the safety instructions below. Then follow charging procedures outlined.

READ ALL INSTRUCTIONS

- **Do not charge or use battery in explosive atmospheres, such as in the presence of flammable liquids, gases or dust.** Inserting or removing the battery from the charger may ignite the dust or fumes.
- **Never force battery pack into charger. Do not modify battery pack in any way to fit into a non-compatible charger as battery pack may rupture causing serious personal injury.**
- Charge the battery packs only in DEWALT chargers.
- **DO NOT splash or immerse in water or other liquids.**
- **Do not store or use the tool and battery pack in locations where the temperature may fall below 4 °C (34 °F) (such as outside sheds or metal buildings in winter), or reach or exceed 40 °C (104 °F) (such as outside sheds or metal buildings in summer).**
- **Do not incinerate the battery pack even if it is severely damaged or is completely worn out.** The battery pack can explode in a fire. Toxic fumes and materials are created when lithium-ion battery packs are burned.
- **If battery contents come into contact with the skin, immediately wash area with mild soap and water.** If battery liquid gets into the eye, rinse water over the open eye for 15 minutes or until irritation ceases. If medical attention is needed, the battery electrolyte is composed of a mixture of liquid organic carbonates and lithium salts.
- **Contents of opened battery cells may cause respiratory irritation.** Provide fresh air. If symptoms persists, seek medical attention.

 **WARNING:** Burn hazard. Battery liquid may be flammable if exposed to spark or flame.

 **WARNING:** Never attempt to open the battery pack for any reason. If battery pack case is cracked or damaged, do not insert into charger. Do not crush, drop or damage battery pack. Do not use a battery pack or charger that has received a sharp blow, been dropped, run over or damaged in any way (i.e., pierced with a nail, hit with a hammer, stepped on). Electric shock or electrocution may result. Damaged battery packs should be returned to service centre for recycling.

 **WARNING:** Fire hazard. Do not store or carry the battery pack so that metal objects can contact exposed battery terminals. For example, do not place the battery pack in aprons, pockets, tool boxes, product kit boxes, drawers, etc., with loose nails, screws, keys, etc.

Transportation

 **WARNING:** Fire hazard. Transporting batteries can possibly cause fire if the battery terminals inadvertently come in contact with conductive materials. When transporting batteries, make sure that the battery terminals are protected and well insulated from materials that could contact them and cause a short circuit.

NOTE: Lithium-ion batteries should not be put in checked baggage.

DEWALT batteries comply with all applicable shipping regulations as prescribed by industry and legal standards which include UN Recommendations on the Transport of Dangerous Goods; International Air Transport Association (IATA) Dangerous Goods Regulations, International Maritime Dangerous Goods (IMDG) Regulations, and the European Agreement Concerning The International Carriage of Dangerous Goods by Road (ADR). Lithium-ion cells and batteries have been tested to section 38.3 of the UN Recommendations on the Transport of Dangerous Goods Manual of Tests and Criteria.

In most instances, shipping a DEWALT battery pack will be excepted from being classified as a fully regulated Class 9 Hazardous Material. In general, only shipments containing a lithium-ion battery with an energy rating greater than 100 Watt Hours (Wh) will require being shipped as fully regulated Class 9. All lithium-ion batteries have the Watt Hour rating marked on the pack. Furthermore, due to regulation complexities, DEWALT does not recommend air shipping lithium-ion battery packs alone regardless of Watt Hour rating. Shipments of tools with batteries (combo kits) can be air shipped as excepted if the Watt Hour rating of the battery pack is no greater than 100 Whr. Regardless of whether a shipment is considered excepted or fully regulated, it is the shipper's responsibility to consult the latest regulations for packaging, labeling/marketing and documentation requirements.

The information provided in this section of the manual is provided in good faith and believed to be accurate at the time the document was created. However, no warranty, expressed or implied, is given. It is the buyer's responsibility to ensure that its activities comply with the applicable regulations.

Transporting the FLEXVOLT™ Battery

The DEWALT FLEXVOLT™ battery has two modes: **Use** and **Transport**.

Use Mode: When the FLEXVOLT™ battery stands alone or is in a DEWALT 18V product, it will operate as an 18V battery. When the FLEXVOLT™ battery is in a 54V or a 108V (two 54V batteries) product, it will operate as a 54V battery.

Transport Mode: When the cap is attached to the FLEXVOLT™ battery, the battery is in Transport mode. Keep the cap for shipping.

When in Transport mode, strings of cells are electrically disconnected within the pack resulting in 3 batteries with a lower Watt hour (Wh) rating as compared to 1 battery with a higher Watt hour rating. This increased quantity of 3 batteries with the lower Watt hour rating can exempt the pack from certain shipping regulations that are imposed upon the higher Watt hour batteries.

For example, the Transport Wh rating might indicate 3 x 36 Wh, meaning 3

Example of Use and Transport Label Marking

 **Use: 108 Wh**
Transport: 3x36 Wh

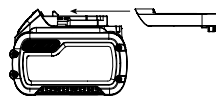

batteries of 36 Wh each. The Use Wh rating might indicate 108 Wh (1 battery implied).

Storage Recommendations

1. The best storage place is one that is cool and dry away from direct sunlight and excess heat or cold. For optimum battery performance and life, store battery packs at room temperature when not in use.
2. For long storage, it is recommended to store a fully charged battery pack in a cool, dry place out of the charger for optimal results.

NOTE: Battery packs should not be stored completely depleted of charge. The battery pack will need to be recharged before use.

Labels on Charger and Battery Pack

In addition to the pictographs used in this manual, the labels on the charger and the battery pack may show the following pictographs:



Read instruction manual before use.



See **Technical Data** for charging time.



Do not probe with conductive objects.



Do not charge damaged battery packs.



Do not expose to water.



Have defective cords replaced immediately.



Charge only between 4 °C and 40 °C.



Only for indoor use.



Discard the battery pack with due care for the environment.

LI-ION



Charge DeWALT battery packs only with designated DeWALT chargers. Charging battery packs other than the designated DeWALT batteries with a DeWALT charger may make them burst or lead to other dangerous situations.



Do not incinerate the battery pack.



USE (without transport cap). Example: Wh rating indicates 108 Wh (1 battery with 108 Wh).



TRANSPORT (with built-in transport cap). Example: Wh rating indicates 3 x 36 Wh (3 batteries of 36 Wh).

Battery Type

The DCR029 operates on any 12 or 18 volt battery pack.

These battery packs may be used: DCB122, DCB124, DCB125, DCB127, DCB181, DCB182, DCB183, DCB183B, DCB184, DCB184B, DCB185, DCB187, DCB546, DCB547, DCB548. Refer to **Technical Data** for more information.

Package Contents

The package contains:

- 1 Radio
- 1 AC adapter
- 1 Li-Ion battery pack (C1, D1, L1, M1, P1, S1, T1, X1, Y1 models)
- 2 Li-Ion battery packs (C2, D2, L2, M2, P2, S2, T2, X2, Y2 models)
- 3 Li-Ion battery packs (C3, D3, L3, M3, P3, S3, T3, X3, Y3 models)
- 1 Instruction manual

NOTE: Battery packs, chargers and kitboxes are not included with N models. Battery packs and chargers are not included with NT models. B models include Bluetooth® battery packs.

NOTE: The Bluetooth® word mark and logos are registered trademarks owned by the Bluetooth®, SIG, Inc. and any use of such marks by DeWALT is under license. Other trademarks and trade names are those of their respective owners.

- Check for damage to the tool, parts or accessories which may have occurred during transport.
- Take the time to thoroughly read and understand this manual prior to operation.

Markings on Radio

The following pictographs are shown on the radio:



Read instruction manual before use.

Date Code Position (Fig. B)

The date code **21**, which also includes the year of manufacture, is printed into the housing.

Example:

2020 XX XX

Year of Manufacture

Description (Fig. A, B)



WARNING: Never modify the power radio or any part of it. Damage or personal injury could result.

- | | |
|-----------------------------|-------------------------|
| 1 ON/OFF button/Volume knob | 8 LCD display |
| 2 Antenna | 9 Bluetooth button |
| 3 Seek/tuner/arrow buttons | 10 Enter/display button |
| 4 Mode button | 11 AUX audio port |
| 5 Radio preset buttons | 12 USB charging port |
| 6 Mute button | 13 Carry handle |
| 7 Menu button | 14 Roll cage |
| | 15 AC adapter |

- **Young children and the infirm.** This appliance is not intended for use by young children or infirm persons without supervision.

- This product is not intended for use by persons (including children) suffering from diminished physical, sensory or mental abilities; lack of experience, knowledge or skills unless they are supervised by a person responsible for their safety. Children should never be left alone with this product.

OPERATION

Instructions for Use



WARNING: Always observe the safety instructions and applicable regulations.



WARNING: To reduce the risk of serious personal injury, turn tool off and disconnect battery pack before making any adjustments or removing/installing attachments or accessories. An accidental start-up can cause injury.

Inserting and Removing the Battery Pack from the Radio (Fig. B)

NOTE: Make sure your battery pack **17** is fully charged.

To Install the Battery Pack into the Radio

1. Align the battery pack **17** with the rails inside the battery receptacle **20**.
2. Slide it into the receptacle until the battery pack is firmly seated in the tool and ensure that you hear the lock snap into place.

To Remove the Battery Pack from the Radio

1. Press the release button **18** and firmly pull the battery pack out of the battery receptacle.
2. Insert battery pack into the charger as described in the charger section of this manual.

Fuel Gauge Battery Packs (Fig. B)

Some DEWALT battery packs include a fuel gauge which consists of three green LED lights that indicate the level of charge remaining in the battery pack.

To actuate the fuel gauge, press and hold the fuel gauge button **19**. A combination of the three green LED lights will illuminate designating the level of charge left. When the level of charge in the battery is below the usable limit, the fuel gauge will not illuminate and the battery will need to be recharged.

NOTE: The fuel gauge is only an indication of the charge left on the battery pack. It does not indicate tool functionality and is subject to variation based on product components, temperature and end-user application.

Powering with the AC Adapter (Fig. B)



WARNING: Use only the AC adapter supplied with this product. Use of any other external power supply could damage the radio or power supply.

To power the radio using the AC adapter **15**, plug the cord into the radio's AC power input **16** found on the back of the radio, then plug the 230V AC cord end into the wall outlet or an appropriate-sized extension cord that is plugged into a wall outlet. Always fully extend the cord before each use.

To prevent interference, locate the adapter as far from the radio as possible.

NOTE: The battery pack must be removed before the AC adapter can be plugged into the AC power input.

Power/Volume Adjustment

1. To turn the radio on, press the ON/OFF button/Volume knob **1**.

NOTE: When the radio is first used it will enter 'DAB' mode and automatically scan for stations. It will then start playing the first station it finds.

2. Turn the ON/OFF button/Volume knob **1** clockwise to increase the volume. To decrease the volume, turn anti-clockwise.

Mode Function

To choose one of the mode functions ('DAB', 'FM', or 'AUX' or Bluetooth®) push the mode button **4** until the desired function is found.

NOTE: Pressing the Bluetooth® button **9** also puts the radio into Bluetooth® mode.

DAB Mode

Tuning

When the unit is first switched on the unit will start in 'DAB'/DAB+' mode and will 'Auto Scan' to find broadcast stations in the local area. Once 'Auto Scan' is complete, use the left or right arrow buttons **3** to scroll through the stations.

NOTE: When moving locations or if reception was poor in the original scan (possible if the antenna was not up), this may result in an empty or incomplete list of available stations. Manually running an 'Auto Scan' will find all available broadcast stations.

To Perform an Auto Scan:

1. Press the Menu button **7**, scroll through the options by pressing the right arrow button **3** until you reach 'Auto Scan'.
2. Press the Enter/Display button **10** to perform the 'Auto Scan'.

Once 'Auto Scan' is complete the radio will play the first station it finds.

Display

Press the Enter/Display Button **10** to alternate between scrolling text, date and station information.

Station Prune

Some stations once received by your radio which are no longer available may display with a ? after the station name.

To remove these stations from the station list, use the 'Prune' function:

1. Press Menu **7** and scroll right to the 'Prune' option.
2. Press Enter/Display **10** to select.

Tune or Seek Function (FM)

There are two tuning methods and one seek method for finding the desired frequency.

To tune:

Press and release the right or left arrow button **3**. Repeat until the desired frequency is found.

To seek:

Press and hold the right or left arrow button **3** for 2 seconds. The tuner frequency will change to the first radio station with acceptable clarity and stop at that station.

To Program the Preset/Memory Buttons

Five 'DAB' and five 'FM' radio stations may be independently set. After programming the buttons, pressing 1, 2, 3, 4, or 5 will instantly change the frequency to the preset station.

1. Set the radio to desired station (see **Tune or Seek Function**).
2. Press and hold one of the desired radio preset buttons **5** until the preset number begins flashing in the LCD display **8**. Release the button and wait for the preset display to stop flashing.

To Adjust the EQ

Bass and treble can be adjusted by changing the Equalisation (EQ) settings of the radio.

1. Press the menu button **7** and use the arrow keys to select **Sound EQ** then press the Enter/Display button **10**.
2. To adjust the bass, rotate the ON/OFF button/Volume knob **1** clockwise to increase, and counterclockwise to decrease.
3. To adjust treble, press enter after adjusting the bass, use the ON/OFF button/Volume knob **1** to adjust the treble level.
4. Press enter to exit **Sound EQ**.

Mute Button

The mute button **6**, located on the front panel, can be used to mute the volume.

Playing Audio from an External Device (Fig. A)

Audio can be played through the radio via a wireless Bluetooth® connection to a compatible Bluetooth® device or by connecting audio device or mobile phone using a 3.5 mm audio cable to the AUX audio port **11** located on the front panel.

Pairing Radio with a Bluetooth® Audio Device

1. Place the radio and the Bluetooth® audio source within 1 m of each other.
2. Turn radio on by pressing the ON/OFF button/Volume knob **1**.
3. Press the Bluetooth® button **9** or use the mode button to put the unit into Bluetooth® (BT) mode. During this time, the radio is trying to find a previously paired device. If found the radio will connect to your device.
4. If another device is to be paired, press and hold the Bluetooth® button to enter pairing mode.
5. Confirm pairing on your device. (Please consult your device's instruction manual for specific pairing instructions.)
6. Once pairing is successful, the radio is now able to stream audio from your device.

NOTE: When the radio is paired to a Bluetooth® device the right and left arrow buttons **3** can be used to skip or go to previous tracks on the audio device.

Connecting a Previously Paired Bluetooth® Audio Device

If a Bluetooth® device has been previously paired to the radio, and within range, it should automatically reconnect when in Bluetooth® (BT) mode. If connection does not occur and you are unable to stream music please follow the instructions for **Pairing Radio with a Bluetooth® Audio Device**.

Timeout Functionality (Fig. A)

To conserve battery life the radio is designed to power off automatically after 15 minutes of inactivity. This inactivity could be due to the device being unpaired for 15 minutes or in the case of the Bluetooth® connection being broken for the same period of time. If the radio powers off due to inactivity of any kind refer to **Connecting a Previously Paired Bluetooth® Audio Device**.

NOTE: Optimum Bluetooth® streaming range is roughly 9 m (line of sight) to the radio but distances up to 30 m are possible. Physical obstacles, other wireless devices or electromagnetic devices may affect the connection quality.

If Bluetooth® connection is lost due to exceeding time of separation, exceeding the optimum distance, obstacles or otherwise, reconnecting your device with the radio may be necessary.

Charging a Mobile Device via USB (Fig. A)

Your mobile device can be charged (up to 2 AMPS) using the USB charging port **12** on the radio. This charging is possible when unit is on, running off of AC power or the battery pack.

Important Radio Notes

1. Reception will vary depending on location and strength of radio signal.
2. Running the radio while connected to certain generators may cause background noise.

MAINTENANCE

Your DEWALT power tool has been designed to operate over a long period of time with a minimum of maintenance. Continuous satisfactory operation depends upon proper tool care and regular cleaning.

Service Notes

This product is not user serviceable. There are no user serviceable parts inside the radio. Servicing at an authorised service centre is required to avoid damage to static sensitive internal components.

**Cleaning**

WARNING: Blow dirt and dust out of the main housing with dry air as often as dirt is seen collecting in and around the air vents. Wear approved eye protection and approved dust mask when performing this procedure.

 **WARNING:** Never use solvents or other harsh chemicals for cleaning the non-metallic parts of the tool. These chemicals may weaken the materials used in these parts. Use a cloth dampened only with water and mild soap. Never let any liquid get inside the tool; never immerse any part of the tool into a liquid.

Optional Accessories

 **WARNING:** Since accessories, other than those offered by DEWALT, have not been tested with this product, use of such accessories with this tool could be hazardous. To reduce the risk of injury, only DEWALT recommended accessories should be used with this product.

Consult your dealer for further information on the appropriate accessories.

Protecting the Environment

 Separate collection. Products and batteries marked with this symbol must not be disposed of with normal household waste.

 Products and batteries contain materials that can be recovered or recycled reducing the demand for raw materials. Please recycle electrical products and batteries according to local provisions. Further information is available at www.2helpU.com.

Rechargeable Battery Pack

This long life battery pack must be recycled when it fails to produce sufficient power on jobs which were easily done before. At the end of its technical life, discard it with due care for our environment:

- Run the battery pack down completely, then remove it from the tool.
- Li-Ion cells are recyclable. Take them to your dealer or a local recycling station. The collected battery packs will be recycled or disposed of properly.



Belgique et Luxembourg België en Luxemburg	DEWALT - Belgium BVBA Egide Walschaertsstraat 16 2800 Mechelen	Tel: NL 32 15 47 37 63 Tel: FR 32 15 47 37 64 Fax: 32 15 47 37 99	www.dewalt.be enduser.BE@SBDinc.com
Danmark	DEWALT (Stanley Black & Decker AS) Roskildevej 22 2620 Alberslund	Tel: 70 20 15 10 Fax: 70 22 49 10	www.dewalt.dk kundeservice.dk@sbdinc.com
Deutschland	DEWALT Richard Klingner Str. 11 65510 Idstein	Tel: 06126-21-0 Fax: 06126-21-2770	www.dewalt.de infodwge@sbdinc.com
Ελλάς	DEWALT (ΕΜΔ) Α.Ε. ΕΑΡΑ-ΓΡΑΦΕΙΑ : Στραβόλιος 7 & Α. Βουλιαγμένης, Γλυφάδα 166 74, Αθήνα SERVICE : Ημερος Τόπος 2 (Χάν Αδάμ) — 193 00 Ασπρόπυργος	Τηλ: 00302108981616 Φαξ: 00302108983570	www.dewalt.gr Greece.Service@sbdinc.com
España	DEWALT Ibérica, S.C.A. Parc de Negocios "Mas Blau" Edificio Muntadas, c/Bergadá, 1, Of. A6 08820 El Prat de Llobregat (Barcelona)	Tel: 934 797 400 Fax: 934 797 419	www.dewalt.es respuesta.postventa@sbdinc.com
France	DEWALT (Stanley Black & Decker France SAS) 62 Chemin de la Bruyère CS 60105, 69574 DARDILLY Cedex	Tel: 04 72 20 39 20 Fax: 04 72 20 39 00	www.dewalt.fr scufr@sbdinc.com
Schweiz Suisse Svizzera	DEWALT In der Luberzen 42 8902 Udorf	Tel: 044 - 755 60 70 Fax: 044 - 730 70 67	www.dewalt.ch service@rofoag.ch
Ireland	DEWALT Building 4500, Kinsale Road Cork Airport Business Park Cork, Ireland	Tel: 00353-2781800 Fax: 01278 1811	www.dewalt.ie Sales.Ireland@sbdinc.com
Italia	DEWALT via Energypark 6 20871 Vimercate (MB), IT	Tel: 800-014353 39 039-9590200 39 039-9590311	www.dewalt.it
Nederlands	DEWALT Netherlands: BVPostbus 83, 6120 AB BORN	Tel: 31 164 283 063 Fax: 31 164 283 200	www.dewalt.nl
Norge	DEWALT Postboks 4613 0405 Oslo, Norge	Tel: 45 25 13 00 Fax: 45 25 08 00	www.dewalt.no kundeservice.no@sbdinc.com
Österreich	DEWALT Werkzeug Vertriebsges m.b.H Oberlaaerstrasse 248, A-1230 Wien	Tel: 01 - 66116 - 0 Fax: 01 - 66116 - 614	www.dewalt.at service.austria@sbdinc.com
Portugal	DEWALT Ed. D Diris, Quina da Fonte Rua dos Malhoes 2, 2A 2ª Esq. Oeiras e S. Juliao da Barra, paço de Arcos e Caxias 2770 071 Paço de Arcos	Tel: +351 214667500 Fax: +351214667580	www.dewalt.pt resposta.posvenda@sbdinc.com
Suomi	DEWALT PL47 00521 Helsinki, Suomi	Puh: 010 400 4333 Faksi: 0800 411 340	www.dewalt.fi asiakaspalvelu.fi@sbdinc.com
Sverige	DEWALT BOX 94 43122 Mölndal Sverige	Tel: 031 68 61 60 Fax: 031 68 60 08	www.dewalt.se kundservice.se@sbdinc.com
Türkiye	Sanayi ve Ticaret Bakanlığı tebliğince kullanim ömrü 7 yıldır. Stanley Black & Decker Turkey Alet Üretim San. Tic. Ltd.Şti. AND Kozatagi - İçerenköy Mah. Umut Sok. AND Ofis Sit. No: 10-12 / 82-83-84 Ataşehir/İstanbul, Türkiye	Tel: +90 216 665 2900 Faks: +90 216 665 2901	www.dewalt.com.tr info-tr@sbdinc.com
United Kingdom	DEWALT, 270 Bath Road; Slough, Berks SL1 4YD	Tel: 01753-567055 Fax: 01753-572112	www.dewalt.co.uk emeaservice@sbdinc.com
Australia	DEWALT 810 Whitehorse Road Box Hill VIC 3128 Australia	Tel: Aust 1800 338 002 Tel: NZ 0800 339 258	www.dewalt.com.au www.dewalt.co.nz
Middle East Africa	DEWALT P.O. Box - 17164, Jebel Ali Free Zone (South), Dubai, UAE	Tel: 971 4 812 7400 Fax: 971 4 2822765	www.dewalt.ae Service.MEA@sbdinc.com