

DEWALT®

МАГАЗИН
БАШ МАЙСТОРА
ПРОФЕСИОНАЛНИ РЕШЕНИЯ



www.DEWALT.com

D28715

Fig. A

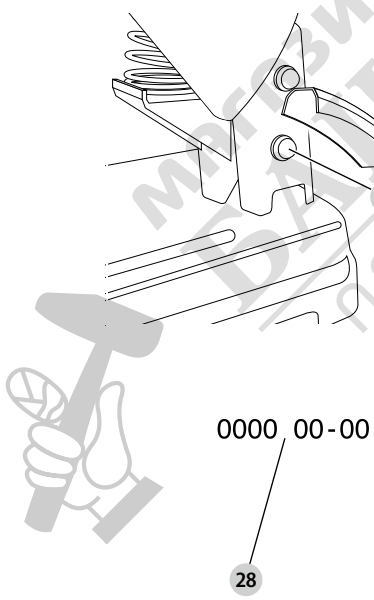
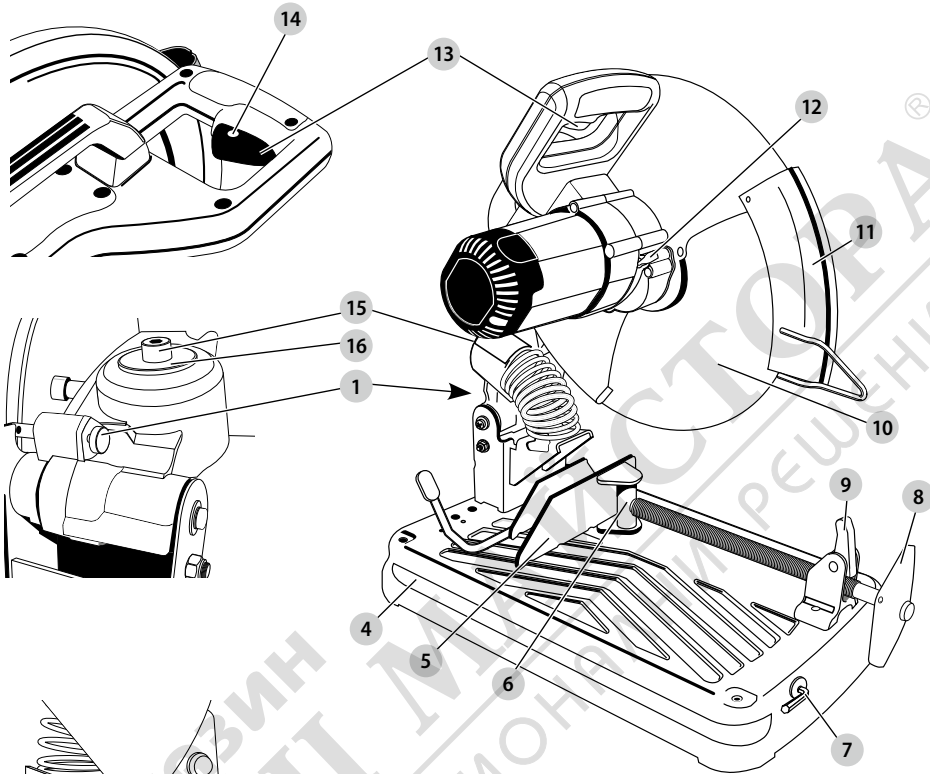

Fig. B

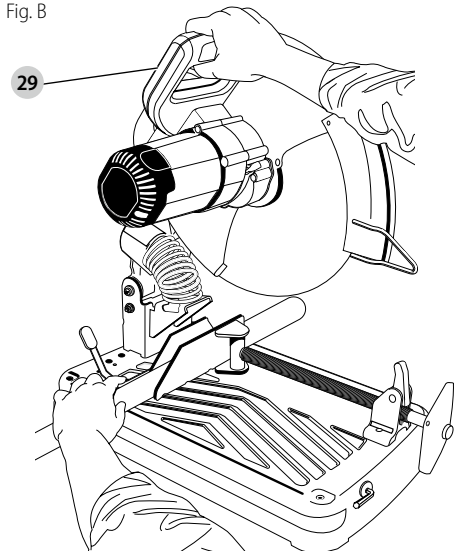

Fig. C

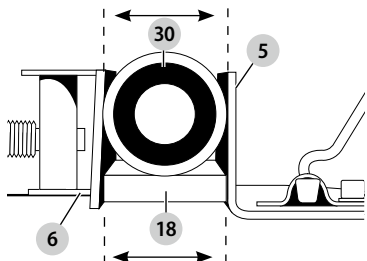

Fig. D

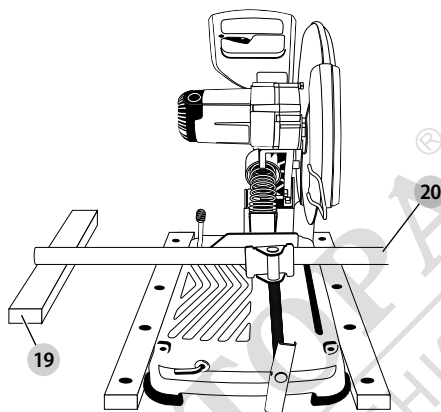

Fig. E

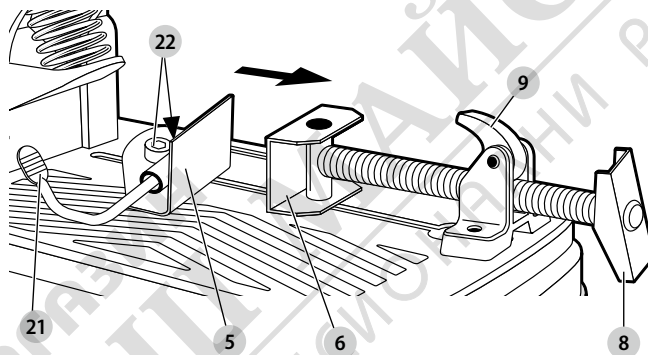

Fig. F

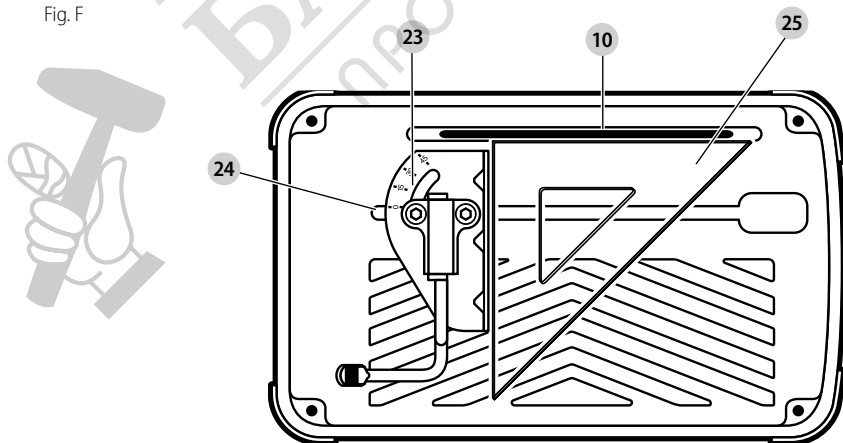

Fig. G

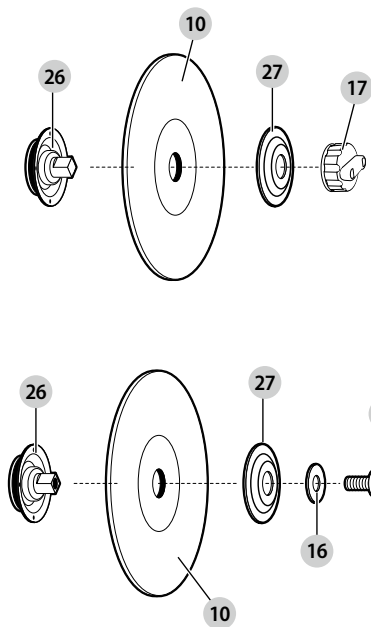

Fig. H

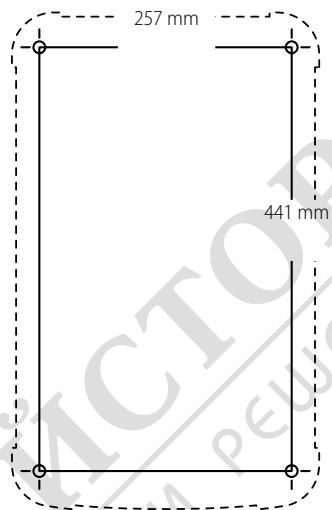
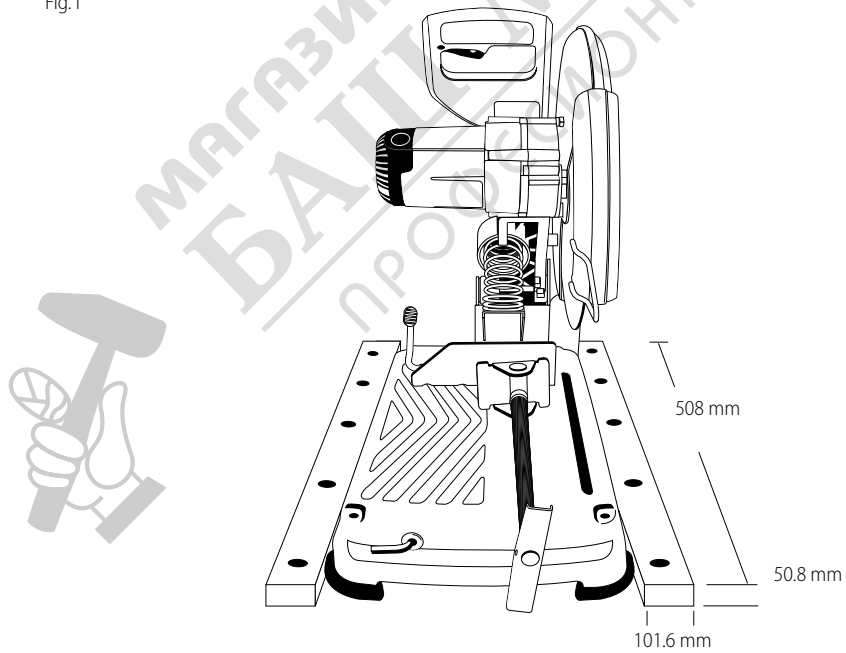

Fig. I



HEAVY-DUTY 355 mm CHOP SAW WITH QUICK-CHANGE CLAMP D28715

Congratulations!

You have chosen a DEWALT tool. Years of experience, thorough product development and innovation make DEWALT one of the most reliable partners for professional power tool users.

Technical Data

		D28715	D28715 (LX)
Voltage	V_{AC}	230	115
UK & Ireland	V_{AC}	230	115
Type		15	15
Power Input	W	2200	2200
No-load speed	min^{-1}	4000	4000
Min. peripheral speed cutting disc	m/s	80	80
Disc diameter	mm	355	355
Disc bore	mm	25.4	25.4
Disc body thickness	mm	3.1	3.1
Thread size of spindle		M10	M10
Type of cutting disc straight, non-recessed			
Cross-cutting capacity at 90°			
circular	mm	110	
square	mm	110 x 110	
rectangular	mm	100 x 200	
angular	mm	140 x 140	
Cross-cutting capacity at 45°			
circular	mm	110	
square	mm	110 x 110	
rectangular	mm	100 x 140	
angular	mm	120 x 120	
Weight	kg	18.5	18.5
Noise values and/or vibration values (tri-ax vector sum) according to EN62841-3-10:			
L_{PA} (emission sound pressure level)	dB(A)	100	98
L_{WA} (sound power level)	dB(A)	112	111
K (uncertainty for the given sound level)	dB(A)	3	3
Vibration emission value $a_{rh} =$			
	m/s^2	6.2	5.3
Uncertainty K =			
	m/s^2	1.5	1.5

The vibration and/or noise emission level given in this information sheet has been measured in accordance with a standardised test given in EN62841 and may be used to compare one tool with another. It may be used for a preliminary assessment of exposure.



WARNING: The declared vibration and/or noise emission level represents the main applications of the tool. However if the tool is used for different applications, with different accessories or poorly maintained, the vibration and/or noise emission may differ. This may significantly increase the exposure level over the total working period.

An estimation of the level of exposure to vibration and/or noise should also take into account the times when the tool is switched off or when it is running but not actually doing the job. This may significantly reduce the exposure level over the total working period.

Identify additional safety measures to protect the operator from the effects of vibration and/or noise such as: maintain the tool and the accessories, keep the hands warm (relevant for vibration), organisation of work patterns.

EC-Declaration of Conformity Machinery Directive



Chop Saw D28715

DEWALT declares that these products described under **Technical Data** are in compliance with:

2006/42/EC, EN62841-1:2015, EN62841-3-10:2015.

These products also comply with Directive 2014/30/EU and 2011/65/EU. For more information, please contact DEWALT at the following address or refer to the back of the manual.

The undersigned is responsible for compilation of the technical file and makes this declaration on behalf of DEWALT.

Markus Rompel
Vice President of Engineering, PTE-Europe
DEWALT, Richard-Klinger-Straße 11,
D-65510, Idstein, Germany
21.04.2020



WARNING: To reduce the risk of injury, read the instruction manual.

Definitions: Safety Guidelines

The definitions below describe the level of severity for each signal word. Please read the manual and pay attention to these symbols.



DANGER: Indicates an imminently hazardous situation which, if not avoided, **will** result in **death or serious injury**.



WARNING: Indicates a potentially hazardous situation which, if not avoided, **could** result in **death or serious injury**.



CAUTION: Indicates a potentially hazardous situation which, if not avoided, **may** result in **minor or moderate injury**.

NOTICE: Indicates a practice **not related to personal injury** which, if not avoided, **may** result in **property damage**.



Denotes risk of electric shock.



Denotes risk of fire.

General Power Tool Safety Warnings



WARNING: Read all safety warnings, illustrations and specifications provided with this power tool.

Failure to follow all warnings listed below may result in electric shock, fire and/or serious injury.

SAVE ALL WARNINGS AND INSTRUCTIONS FOR FUTURE REFERENCE

The term "power tool" in the warnings refers to your mains-operated (corded) power tool or battery-operated (cordless) power tool.

1) Work area safety

- Keep work area clean and well lit.** Cluttered or dark areas invite accidents.
- Do not operate power tools in explosive atmospheres, such as in the presence of flammable liquids, gases or dust.** Power tools create sparks which may ignite the dust or fumes.
- Keep children and bystanders away while operating a power tool.** Distractions can cause you to lose control.

2) Electrical safety

- Power tool plugs must match the outlet. Never modify the plug in any way. Do not use any adapter plugs with earthed (grounded) power tools.** Unmodified plugs and matching outlets will reduce risk of electric shock.
- Avoid body contact with earthed or grounded surfaces such as pipes, radiators, ranges and refrigerators.** There is an increased risk of electric shock if your body is earthed or grounded.
- Do not expose power tools to rain or wet conditions.** Water entering a power tool will increase the risk of electric shock.
- Do not abuse the cord. Never use the cord for carrying, pulling or unplugging the power tool. Keep cord away from heat, oil, sharp edges or moving parts.** Damaged or entangled cords increase the risk of electric shock.
- When operating a power tool outdoors, use an extension cord suitable for outdoor use.** Use of a cord suitable for outdoor use reduces the risk of electric shock.

- If operating a power tool in a damp location is unavoidable, use a residual current device (RCD) protected supply.** Use of an RCD reduces the risk of electric shock.

3) Personal safety

- Stay alert, watch what you are doing and use common sense when operating a power tool. Do not use a power tool while you are tired or under the influence of drugs, alcohol or medication.** A moment of inattention while operating power tools may result in serious personal injury.
- Use personal protective equipment. Always wear eye protection.** Protective equipment such as dust mask, non-skid safety shoes, hard hat, or hearing protection used for appropriate conditions will reduce personal injuries.
- Prevent unintentional starting. Ensure the switch is in the off position before connecting to power source and/or battery pack, picking up or carrying the tool.** Carrying power tools with your finger on the switch or energising power tools that have the switch on invites accidents.
- Remove any adjusting key or wrench before turning the power tool on.** A wrench or a key left attached to a rotating part of the power tool may result in personal injury.
- Do not overreach. Keep proper footing and balance at all times.** This enables better control of the power tool in unexpected situations.
- Dress properly. Do not wear loose clothing or jewellery. Keep your hair, clothing and gloves away from moving parts.** Loose clothes, jewellery or long hair can be caught in moving parts.
- If devices are provided for the connection of dust extraction and collection facilities, ensure these are connected and properly used.** Use of dust collection can reduce dust-related hazards.
- Do not let familiarity gained from frequent use of tools allow you to become complacent and ignore tool safety principles.** A careless action can cause severe injury within a fraction of a second.

4) Power tool use and care

- Do not force the power tool. Use the correct power tool for your application.** The correct power tool will do the job better and safer at the rate for which it was designed.
- Do not use the power tool if the switch does not turn it on and off.** Any power tool that cannot be controlled with the switch is dangerous and must be repaired.
- Disconnect the plug from the power source and/or the battery pack, if detachable, from the power tool before making any adjustments, changing accessories, or storing power tools.** Such preventive safety measures reduce the risk of starting the power tool accidentally.

- d) **Store idle power tools out of the reach of children and do not allow persons unfamiliar with the power tool or these instructions to operate the power tool.**
Power tools are dangerous in the hands of untrained users.
- e) **Maintain power tools and accessories. Check for misalignment or binding of moving parts, breakage of parts and any other condition that may affect the power tool's operation. If damaged, have the power tool repaired before use.** *Many accidents are caused by poorly maintained power tools.*
- f) **Keep cutting tools sharp and clean.** *Properly maintained cutting tools with sharp cutting edges are less likely to bind and are easier to control.*
- g) **Use the power tool, accessories and tool bits etc., in accordance with these instructions taking into account the working conditions and the work to be performed.** *Use of the power tool for operations different from those intended could result in a hazardous situation.*
- h) **Keep handles and grasping surfaces dry, clean and free from oil and grease.** *Slippery handles and grasping surfaces do not allow for safe handling and control of the tool in unexpected situations.*
- g) **The arbour size of wheels and flanges must properly fit the spindle of the power tool.** *Wheels and flanges with arbour holes that do not match the mounting hardware of the power tool will run out of balance, vibrate excessively and may cause loss of control.*
- h) **Do not use damaged wheels. Before each use, inspect the wheels for chips and cracks. If the power tool or wheel is dropped, inspect for damage or install an undamaged wheel. After inspecting and installing the wheel, position yourself and bystanders away from the plane of the rotating wheel and run the power tool at maximum no load speed for one minute.** *Damaged wheels will normally break apart during this test time.*
- i) **Wear personal protective equipment. Depending on application, use face shield, safety goggles or safety glasses. As appropriate, wear dust mask, hearing protectors, gloves and shop apron capable of stopping small abrasive or workpiece fragments. The eye protection must be capable of stopping flying debris generated by various operations. The dust mask or respirator must be capable of filtering particles generated by your operation.** *Prolonged exposure to high intensity noise may cause hearing loss.*
- j) **Keep bystanders a safe distance away from work area. Anyone entering the work area must wear personal protective equipment.** *Fragments of workpiece or of a broken wheel may fly away and cause injury beyond immediate area of operation.*
- k) **Position the cord clear of the spinning accessory.** *If you lose control, the cord may be cut or snagged and your hand or arm may be pulled into the spinning wheel.*
- l) **Regularly clean the power tool's air vents.** *The motor's fan can draw the dust inside the housing and excessive accumulation of powdered metal may cause electrical hazards.*
- m) **Do not operate the power tool near flammable materials. Do not operate the power tool while placed on a combustible surface such as wood.** *Sparks could ignite these materials.*
- n) **Do not use accessories that require liquid coolants.** *Using water or other liquid coolants may result in electrocution or shock.*

5) Service

- a) **Have your power tool serviced by a qualified repair person using only identical replacement parts.** *This will ensure that the safety of the power tool is maintained.*

Safety Warnings for Cut off Machines

- a) **Position yourself and bystanders away from the plane of the rotating wheel.** *The guard helps to protect the operator from broken wheel fragments and accidental contact with wheel.*
- b) **Use only bonded reinforced or diamond cut-off wheels for your power tool. Just because an accessory can be attached to your power tool, it does not assure safe operation.**
NOTE: *The wording bonded reinforced or diamond is used as applicable depending on the designation of the tool.*
- c) **The rated speed of the accessory must be at least equal to the maximum speed marked on the power tool.** *Accessories running faster than their rated speed can break and fly apart.*
- d) **Wheels must be used only for recommended applications. For example: do not grind with the side of a cut-off wheel.** *Abrasive cut-off wheels are intended for peripheral grinding, side forces applied to these wheels may cause them to shatter.*
- e) **Always use undamaged wheel flanges that are of correct diameter for your selected wheel.** *Proper wheel flanges support the wheel thus reducing the possibility of wheel breakage.*
- f) **The outside diameter and the thickness of your accessory must be within the capacity rating of your power tool.** *Incorrectly sized accessories cannot be adequately guarded or controlled.*

Kickback and Related warnings

Kickback is a sudden reaction to a pinched or snagged rotating wheel. Pinching or snagging causes rapid stalling of the rotating wheel which in turn causes the uncontrolled cutting unit to be forced upwards toward the operator.

For example, if an abrasive wheel is snagged or pinched by the workpiece, the edge of the wheel that is entering into the pinch point can dig into the surface of the material causing the wheel to climb out or kick out. Abrasive wheels may also break under these conditions.

ENGLISH

Kickback is the result of power tool misuse and/or incorrect operating procedures or conditions and can be avoided by taking proper precautions as given below.

- a) **Maintain a firm grip on the power tool and position your body and arm to allow you to resist kickback forces.** The operator can control upward kickback forces, if proper precautions are taken.
- b) **Do not position your body in line with the rotating wheel.** If kickback occurs, it will propel the cutting unit upwards toward the operator.
- c) **Do not attach a saw chain, woodcarving blade, segmented diamond wheel with a peripheral gap greater than 10 mm or toothed saw blade.** Such blades create frequent kickback and loss of control.
- d) **Do not "jam" the wheel or apply excessive pressure. Do not attempt to make an excessive depth of cut.** Overstressing the wheel increases the loading and susceptibility to twisting or binding of the wheel in the cut and the possibility of kickback or wheel breakage.
- e) **When the wheel is binding or when interrupting a cut for any reason, switch off the power tool and hold the cutting unit motionless until the wheel comes to a complete stop. Never attempt to remove the wheel from the cut while the wheel is in motion otherwise kickback may occur.** Investigate and take corrective action to eliminate the cause of wheel binding.
- f) **Do not restart the cutting operation in the workpiece. Let the wheel reach full speed and carefully re-enter the cut.** The wheel may bind, walk up or kickback if the power tool is restarted in the workpiece.
- g) **Support any oversized workpiece to minimize the risk of wheel pinching and kickback. Large workpieces tend to sag under their own weight.** Supports must be placed under the workpiece near the line of cut and near the edge of the workpiece on both sides of the wheel.

Additional Safety Warnings for Chop Saws

- In operation, avoid bouncing the cutting disc or giving it rough treatment. If this occurs, stop the tool and inspect the cutting disc.
- Do not operate the tool while standing in line with the cutting disc. Keep other persons away from the work area.
- Be aware of cutting chips and the material being cut. They may be sharp and hot. Allow cut off parts to cool before handling.
- The spark deflector becomes hot during use. Avoid touching or adjusting the spark deflector immediately after operation.
- Switch off the tool and wait for the cutting disc to stop before moving the workpiece or changing the settings.
- After switching off, never attempt to stop the cutting disc by pressing against the side of the disc.
- Do not use cutting fluids. These fluids could ignite or cause electrical shock.
- Check that the workpiece is properly supported.

- Use the cutting discs recommended by the manufacturer only. Do not use tools for purposes not intended; for example do not use circular saw blade to cut tree limbs or logs.
- The max. allowable speed of the cutting disc must always be equal to or greater than the no-load speed of the tool specified on the nameplate.
- Do not use cutting discs that do not conform to the  dimensions stated in the **Technical Data**.
- Read the operating instructions supplied by the wheel manufacturer.
- Ensure that the abrasive wheel is correctly fitted and tightened before use.
- Let the tool run at no-load in a safe position for at least 30 seconds. If there is a considerable vibration or if any other defect occurs, stop the tool and check it to determine the cause.
- Do not use cutting discs for side grinding.
- Do not cut concrete, brick, tile or ceramic materials.
- Do not cut wood, plastic or synthetic materials.
- Do not cut cast-iron materials.
- Never cut magnesium materials.
- Do not cut electrically live material.
- Use this tool in a well-ventilated area. Do not operate the tool near flammable liquids, gases or dust. Sparks or hot chips from cutting or arcing motor brushes may ignite combustible materials.
- Regularly clear the ventilation slots when working in dusty conditions. If it should become necessary to clean the slots, always use a soft brush; remember to unplug the machine first.
- Always store cutting discs well-protected and in a dry place, out of reach of children.

Residual Risks

- The following risks are inherent to the use of these machines:
 - injuries caused by touching the rotating parts.
 - injuries caused by disruption of the cutting disc.
- These risks are most evident:
 - within the range of operation
 - within the range of the rotating machine parts
- In spite of the application of the relevant safety regulations and the implementation of safety devices, certain residual risks cannot be avoided. These are:
 - Impairment of hearing.
 - Risk of accidents caused by the uncovered parts of the rotating cutting disc.
 - Risk of injury when changing the disc.
 - Risk of squeezing fingers when opening the guards.

Electrical Safety

The electric motor has been designed for one voltage only. Always check that the power supply corresponds to the voltage on the rating plate.



Your DeWALT tool is double insulated in accordance with EN62841; therefore no earth wire is required.



WARNING: 115 V units have to be operated via a fail-safe isolating transformer with an earth screen between the primary and secondary winding.

If the supply cord is damaged, it must be replaced only by DeWALT or an authorised service organisation.

Mains Plug Replacement (U.K. & Ireland Only)

If a new mains plug needs to be fitted:

- Safely dispose of the old plug.
- Connect the brown lead to the live terminal in the plug.
- Connect the blue lead to the neutral terminal.



WARNING: No connection is to be made to the earth terminal.

Follow the fitting instructions supplied with good quality plugs. Recommended fuse: 13 A.

Using an Extension Cable

If an extension cable is required, use an approved 3-core extension cable suitable for the power input of this tool (see **Technical Data**). The minimum conductor size is 1.5 mm²; the maximum length is 30 m.

When using a cable reel, always unwind the cable completely.

Package Contents

The package contains:

- 1 Chopsaw
- 1 Cutting disc
- 1 Hex key
- 1 Instruction manual
- Check for damage to the tool, parts or accessories which may have occurred during transport.
- Take the time to thoroughly read and understand this manual prior to operation.

Markings on Tool

The following pictograms are shown on the tool:



Read instruction manual before use.



Wear ear protection.



Wear eye protection.



Bore Diameter

Date Code Position (Fig. A)

The Date Code **28**, which also includes the year of manufacture, is printed into the housing.

Example:

2020 XX XX

Year of Manufacture

Description (Fig. A, G)



WARNING: Never modify the power tool or any part of it. Damage or personal injury could result.

- | | |
|-------------------------|--------------------------------------|
| 1 Lock pin | 10 Wheel |
| 2 Spark deflector screw | 11 Spark guard |
| 3 Spark deflector | 12 Wheel lock lever |
| 4 Base | 13 Trigger switch |
| 5 Fence | 14 Padlock hole |
| 6 Vise | 15 Extra blade bolt |
| 7 8 mm hex wrench | 16 Extra blade bolt washer |
| 8 Crank | 17 Quick-Change blade clamp (Fig. G) |
| 9 Vise lever | |

Intended Use

Your D28715 chop saw has been designed for the cutting of variously shaped steel materials.

DO NOT use under wet conditions or in presence of flammable liquids or gases.

The D28715 chop saw is a professional power tool.

DO NOT let children come into contact with the tool. Supervision is required when inexperienced operators use this tool.

- **Young children and the infirm.** This appliance is not intended for use by young children or infirm persons without supervision.
- This product is not intended for use by persons (including children) suffering from diminished physical, sensory or mental abilities; lack of experience, knowledge or skills unless they are supervised by a person responsible for their safety. Children should never be left alone with this product.

Connecting to the Mains

The mains supply to be used for this machine must be equipped with a 16 A cut-out fuse with time delay.

Voltage Drops

In rush currents cause short-time voltage drops. Under unfavourable power supply conditions, other equipment may be affected. If the system impedance of the power supply is lower than 0.25 Ω, disturbances are unlikely to occur.

OPERATION

Instructions for Use



WARNING: Always observe the safety instructions and applicable regulations.

⚠ WARNING: To reduce the risk of serious personal injury, turn tool off and disconnect tool from power source before making any adjustments or removing/installing attachments or accessories. Be sure the trigger switch is in the OFF position. An accidental start-up can cause injury.

Proper Hand Position (Fig. B)

⚠ WARNING: To reduce the risk of serious personal injury, ALWAYS use proper hand position as shown.

⚠ WARNING: To reduce the risk of serious personal injury, ALWAYS hold securely in anticipation of a sudden reaction.

Proper hand position requires one hand on the main handle **29**, with the other hand guiding the workpiece.

Soft Start Feature

Time Delay relay (TDR)

The soft start feature allows a slow speed run-up over 300 ms to avoid an initial jerk when starting. This feature is also particularly useful when the installed fuse value is too low or not of inert character.

Cutting Capacity

The wide vise opening and high pivot point provide cutting capacity for many large pieces. Use the cutting capacity chart to determine total maximum size of cuts that can be made with a new wheel.

⚠ CAUTION: Certain large, circular or irregularly shaped objects may require additional holding means if they cannot be held securely in vise.

⚠ CAUTION: Do not cut magnesium with this tool. Damage to the saw and personal injury may result.

To Carry (Fig. A)

Fold down unit to position where you can carry the saw. Push in lock pin **1** to lock arm down.

Unlocking (Fig. A)

To unlock tool and raise head, depress motor arm slightly and pull lock pin **1** out. Motor arm will then pivot upward.

Material Clamping and Supporting (Fig. C, D)

- Angles are best clamped and cut with both legs resting against base.
- A spacer block **18** slightly narrower than the workpiece **30** can be used to increase wheel utilization (Fig. C).
- Long workpieces must be supported by a block **19** so it will be level with top of base (Fig. D). The cut-off end **20** should be free to fall downward to avoid wheel binding.

Spark Deflector Adjustment (Fig. A)

To best deflect sparks away from surrounding persons and materials, loosen the screw **2**, adjust the spark deflector **3** and then retighten screw.

NOTICE: Risk of property damage. Do not allow cordset to come into contact with deflector or sparks as damage to cordset may occur.

Vise Operation (Fig. E)

The vise has a quick travel feature. To release the vise **6** when it is clamped tightly, turn the crank **8** counterclockwise one or two times to remove clamping pressure. Lift the vise lever **9** up. Pull crank assembly out as far as desired. The vise may be shoved into work without cranking. Lower vise lever then tighten vise on work by using crank.

Fence Operation (Fig. E)

⚠ WARNING: To reduce the risk of injury, turn unit off and disconnect machine from power source before installing and removing accessories, before adjusting or changing set-ups or when making repairs. Be sure the trigger switch is in the OFF position. An accidental start-up can cause injury.

The fence **5** requires no tools to adjust. The quick-release clamp lever **21** unlocks and locks the fence. When the lever is rotated fully forward, the fence is unlocked. The fence can then be freely moved forward, backward or rotated to allow for the best cutting position for a new wheel and as the wheel wears.

Rotating the lever fully to the rear locks the fence in position selected. If the bottom leg of the lever is not horizontal (parallel to the base), the fence is not locked. Lever will only lock fence when there is strong resistance to moving it to rear. If resistance is light, adjust clamping force by tightening slightly the two bolts **22** holding the fence to the base. Test by reclamping and attempt to move fence.

Fence Angle Adjustment (Fig. F)

⚠ WARNING: To reduce the risk of injury, turn unit off and disconnect machine from power source before installing and removing accessories, before adjusting or changing set-ups or when making repairs. Be sure the trigger switch is in the OFF position. An accidental start-up can cause injury.

The angle adjustment indicator **23** is part of fence clamping system. Align the desired angle indicator line with the edge of the slot **24** in base.

For a more accurate square cut

1. Unlock the fence.
2. Push the arm down until the wheel extends into the base.
3. Place a square **25** against the wheel and adjust the fence against the square.
4. Lock the fence into position.

Usage (Fig. A, B)

Refer to Figure B for proper body positioning during use.

To start the tool, depress the trigger switch **13**. To turn the tool off, release the trigger switch. Keep hands and material from wheel until it has coasted to a stop.

To prevent unauthorized use of tool, install a standard padlock (not included) into the padlock hole **14** located in the trigger.

Removal and Installation of Wheels

(Fig. A, G)

-  **WARNING:** To reduce the risk of injury, turn unit off and disconnect machine from power source before installing and removing accessories, before adjusting or changing set-ups or when making repairs. Be sure the trigger switch is in the OFF position. An accidental start-up can cause injury.

The Quick-Change blade clamp requires no tools to change the blade.

1. Push in wheel lock lever **12** and rotate wheel **10** by hand until wheel lock lever engages slot in inside flange **26** to lock wheel. Loosen the Quick-Change blade clamp **17** counterclockwise. Clamp has right-hand thread.
2. Remove the Quick-Change blade clamp **17**, blade clamp washer **27** and old wheel **10** by hand.
3. Make sure flange surfaces are clean and flat. Install the new abrasive wheel by reversing the above steps.
4. Tighten the Quick-Change blade clamp clockwise until the knob clicks as least three times to ensure the knob is tight. The Quick-Change blade clamp cannot be overtightened.

NOTE: Do not overtighten bolt. An extra blade bolt **15** and blade bolt washer **16** are stored on the back of the motor arm. The bolt and washer must be used together to safely clamp blade.

-  **WARNING:** Risk of personal injury. Check the work surface that the chop saw rests on when replacing with a new abrasive wheel. It is possible that the wheel may contact ANY ITEMS OR STRUCTURE THAT EXTENDS ABOVE work surface (under the base) when the arm is fully lowered.

Mounting (Fig. H, I)

-  **CAUTION:** Tool must be supported on stable, level, non-skid surface to prevent unexpected movement when operating.

Procedure For Permanent Mounting

1. Drill four holes 8 mm through the work surface (Fig. H).
2. Insert 1/4–20 screws down through the holes in the base and through holes in mounting surface. The approximate length of the screws should be the thickness of the mounting surface plus 102 mm.

Cradle Mounting

1. Cut two boards approximately 508 x 50.8 x 101.6 mm wide.
2. Place chop saw at desired work location.
3. Place boards tightly along side, and nail to work surface (Fig. I).

Operation Tips for More Accurate Cuts

- Allow the wheel to do the cutting. Excessive force will cause the wheel to glaze reducing cutting efficiency and/or to deflect causing inaccurate cuts.
- Properly adjust fence angle.
- Make sure material is laying flat across base.
- Properly clamp material to avoid movement and vibration.

MAINTENANCE

Your DEWALT power tool has been designed to operate over a long period of time with a minimum of maintenance. Continuous satisfactory operation depends upon proper tool care and regular cleaning.

-  **WARNING:** To reduce the risk of serious personal injury, turn tool off and disconnect tool from power source before making any adjustments or removing/installing attachments or accessories. Be sure the trigger switch is in the OFF position. An accidental start-up can cause injury.





Lubrication

Closed-type, grease-sealed ball bearings are used throughout. These bearings have sufficient lubrication packed in them at the factory to last the life of the chop saw.



Cleaning

-  **WARNING:** Blow dirt and dust out of the main housing with dry air as often as dirt is seen collecting in and around the air vents. Wear approved eye protection and approved dust mask when performing this procedure.

-  **WARNING:** Never use solvents or other harsh chemicals for cleaning the non-metallic parts of the tool. These chemicals may weaken the materials used in these parts. Use a cloth dampened only with water and mild soap. Never let any liquid get inside the tool; never immerse any part of the tool into a liquid.

Optional Accessories

-  **WARNING:** Since accessories, other than those offered by DEWALT, have not been tested with this product, use of such accessories with this tool could be hazardous. To reduce the risk of injury, only DEWALT recommended accessories should be used with this product.

Consult your dealer for further information on the appropriate accessories.

Use only high-strength Type 1 organic bonded wheels rated 4100 rpm or higher.

Protecting the Environment



Separate collection. Products and batteries marked with this symbol must not be disposed of with normal household waste.

 Products and batteries contain materials that can be recovered or recycled reducing the demand for raw materials. Please recycle electrical products and batteries according to local provisions. Further information is available at www.2helpU.com.