

D	Originalbetriebsanleitung Akku-Luftpumpe	FIN	Alkuperäiskäyttöohje Akku-ilmapumppu
GB	Original operating instructions Cordless air pump	SLO	Originalna navodila za uporabo Akumulatorska zračna črpalka
F	Instructions d'origine Pompe à air à accumulateur	H	Eredeti használati utasítás Akkus-légpumpa
I	Istruzioni per l'uso originali Pompa pneumatica a batteria	RO	Instrucțiuni de utilizare originale Pompă pneumatică cu acumulator
DK/ N	Original betjeningsvejledning Akku-luftpumpe	GR	Πρωτότυπες Οδηγίες χρήσης Αεραντλία μπαταρίας
S	Original-bruksanvisning Batteridrivnen luftpump	P	Manual de instrucções original Bomba de ar sem fio
CZ	Originální návod k obsluze Akumulátorový vzduchový kom- presor	HR/ BIH	Originalne upute za uporabu Baterijska zračna pumpa
SK	Originálny návod na obsluhu Akumulátorová vzduchová pumpa	RS	Originalna uputstva za upotrebu Akumulatorska vazдушna pumpa
NL	Originele handleiding Accu luchtpomp	PL	Instrukcja oryginalną Pompka akumulatorowa
E	Manual de instrucciones original Bomba neumática inalámbrica	TR	Orijinal Kullanma Talimatı Hibrit kompresör
		EE	Originaalkasutusjuhend Akuga õhupump

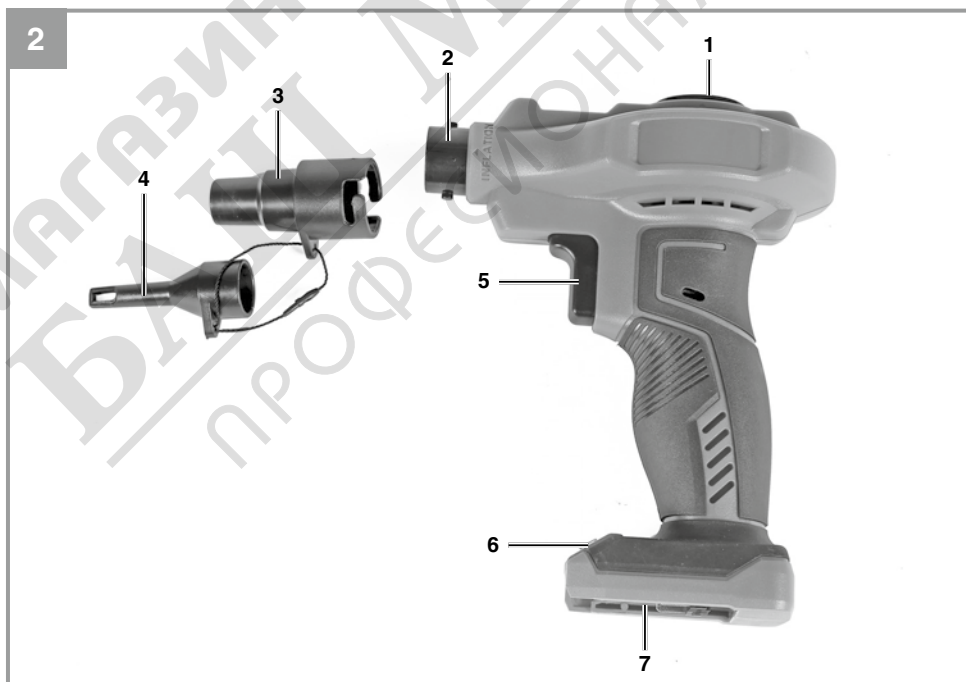

Art.-Nr.: 20.701.10

I.-Nr.: 21010

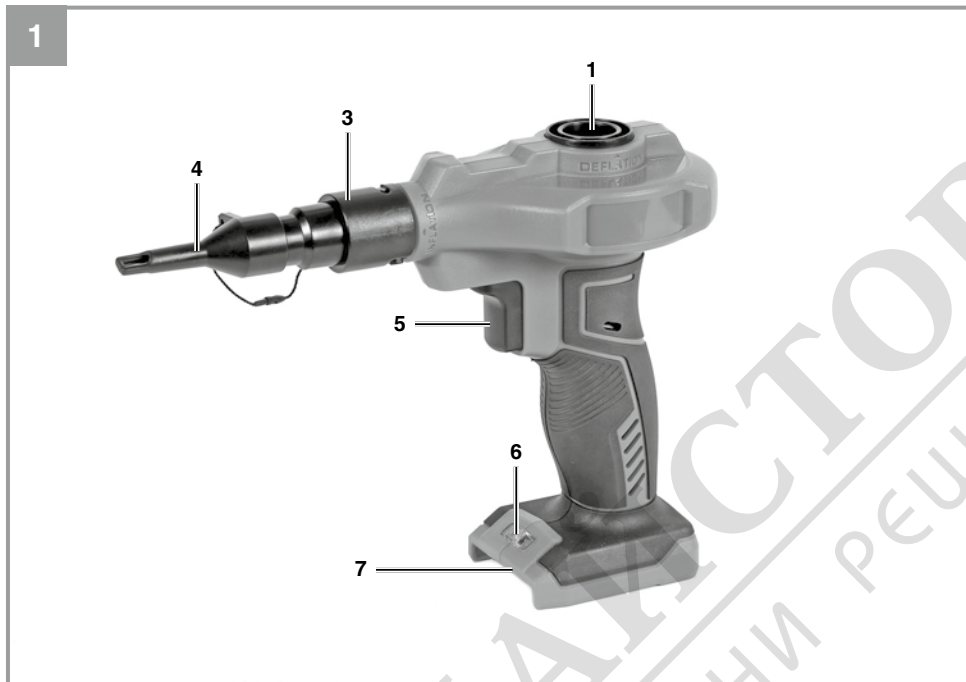

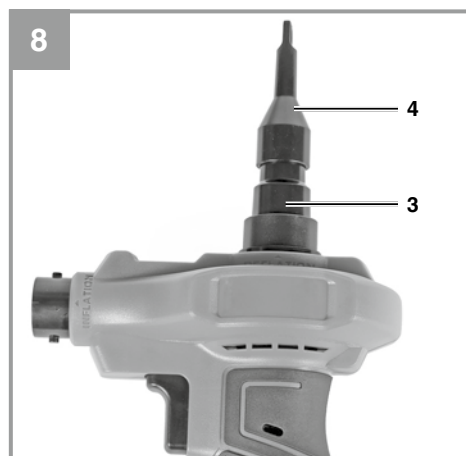
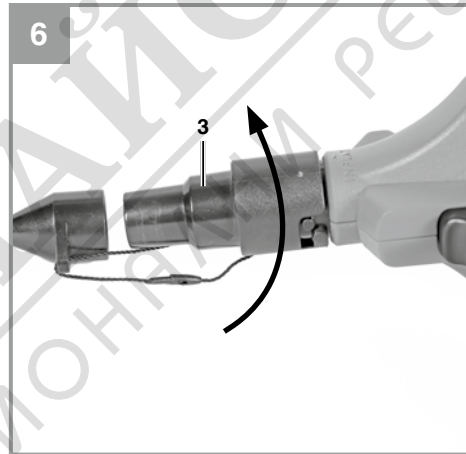
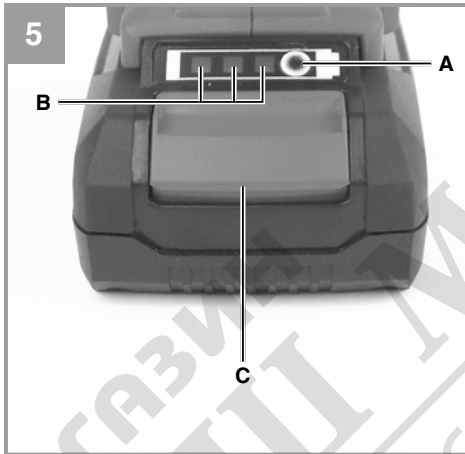
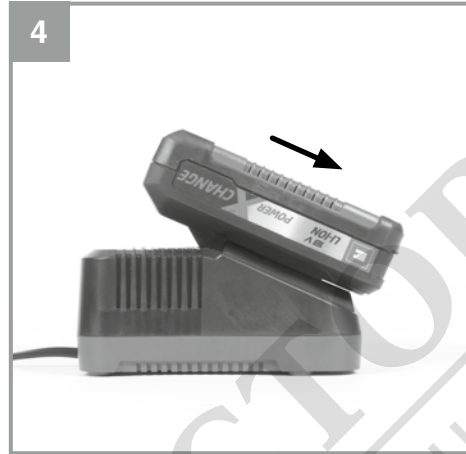
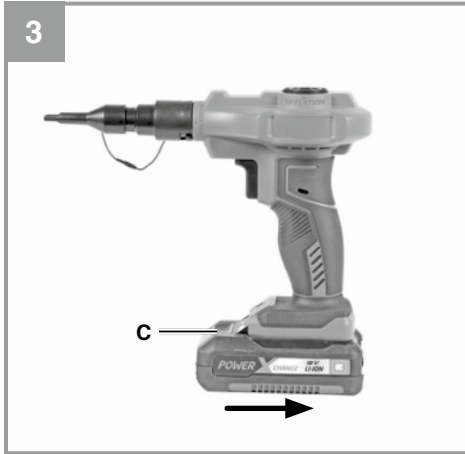

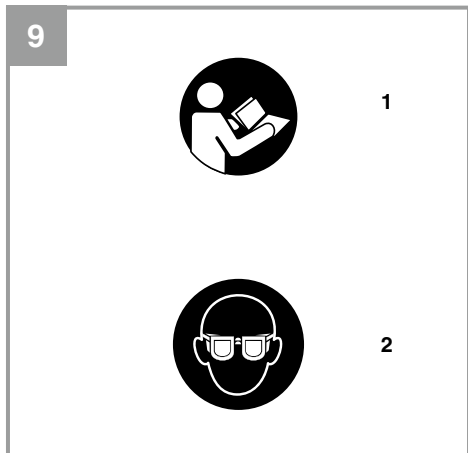

МАГАЗИН
БАШ МАЙСТОРА[®]
ПРОФЕСИОНАЛНИ РЕШЕНИЯ

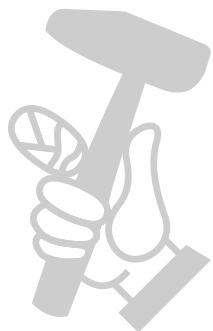

Danger!

When using the equipment, a few safety precautions must be observed to avoid injuries and damage. Please read the complete operating instructions and safety regulations with due care. Keep this manual in a safe place, so that the information is available at all times. If you give the equipment to any other person, hand over these operating instructions and safety regulations as well. We cannot accept any liability for damage or accidents which arise due to a failure to follow these instructions and the safety instructions.

Explanation of the symbols used (see Fig. 9)

1. **Danger!** - Read the operating instructions to reduce the risk of injury.
2. **Caution! Wear safety goggles.** Sparks generated during working or splinters, chips and dust emitted by the device can cause loss of sight.

1. Safety regulations

The corresponding safety information can be found in the enclosed booklet.

Warning!

Read all the safety information, instructions, illustrations and technical data provided on or with this power tool. Failure to adhere to the following instructions may result in electric shock, fire and/or serious injury.

Keep all the safety information and instructions in a safe place for future use.

This equipment can be used by children of 8 years and older and by people with limited physical, sensory or mental capacities or those with no experience and knowledge if they are supervised or have received instruction in how to use the equipment safely and understand the dangers which result from such use. Children are not allowed to play with the equipment. Unless supervised, children are not allowed to clean the equipment and carry out user-level maintenance work.

2. Layout and items supplied**2.1 Layout (Fig. 1/2)**

1. Suction connector
2. Blow connector
3. Large adapter
4. Small adapter
5. On/Off switch
6. LED lamp
7. Battery mount

2.2 Items supplied

Please check that the article is complete as specified in the scope of delivery. If parts are missing, please contact our service center or the sales outlet where you made your purchase at the latest within 5 working days after purchasing the product and upon presentation of a valid bill of purchase. Also, refer to the warranty table in the service information at the end of the operating instructions.

- Open the packaging and take out the equipment with care.
- Remove the packaging material and any packaging and/or transportation braces (if available).
- Check to see if all items are supplied.
- Inspect the equipment and accessories for transport damage.
- If possible, please keep the packaging until the end of the guarantee period.

Danger!

The equipment and packaging material are not toys. Do not let children play with plastic bags, foils or small parts. There is a danger of swallowing or suffocating!

- Cordless air pump
- Large adapter
- Small adapter
- Original operating instructions
- Safety information

3. Proper use

This machine is designed exclusively for inflating high-volume items such as rubber dinghies and large air mattresses. It is not suitable for vehicle tires, bicycle tires and inflatable low-volume leisure, sports and beach articles.

The equipment is to be used only for its prescribed purpose. Any other use is deemed to be a case of misuse. The user / operator and not the manufacturer will be liable for any damage or injuries of any kind caused as a result of this.

Please note that our equipment has not been designed for use in commercial, trade or industrial applications. Our warranty will be voided if the machine is used in commercial, trade or industrial businesses or for equivalent purposes.

4. Technical data

Rated voltage: 18V DC
 Protection class: III
 Max. working pressure: 5.3 kPa (0.053 bar)
 Max. air delivery rate: 670 l/min
 Idling speed no 18,700 rpm
 Approx. weight without battery: 0.6 kg

Sound pressure level L_{pA} 83 dB(A)
 Uncertainty K_{pA} 3 dB (A)
 Sound power level L_{WA} 94 dB(A)
 Uncertainty K_{WA} 3 dB(A)
 Sound power level L_{WAd} 97 dB(A)

Important!

The machine is supplied without rechargeable batteries and without a charger, and is allowed to be used only with the lithium-ion batteries of the Power-X-Change series!

The lithium-ion batteries of the Power-X-Change series are allowed to be charged only with Power-X chargers.

Handle

Vibration emission value $a_h = 2.14 \text{ m/s}^2$
 Uncertainty $K = 1.5 \text{ m/s}^2$

The noise from the equipment might exceed 85 dB(A). The operator will require noise protection measures if this is the case.

The stated vibration emission levels and stated noise emission values were measured in accordance with a set of standardized criteria and can be used to compare one power tool with another.

The stated vibration emission levels and stated noise emission values can also be used to make an initial assessment of exposure.

Warning:

The vibration and noise emission levels may vary from the level specified during actual use, depending on the way in which the power tool is used, especially the type of workpiece it is used for.

Important!

The vibration value changes according to the area of application of the electric equipment and may exceed the specified value in exceptional circumstances.

Keep the noise emissions and vibrations to a minimum.

- Only use appliances which are in perfect working order.
- Service and clean the appliance regularly.
- Adapt your working style to suit the appliance.
- Do not overload the appliance.
- Have the appliance serviced whenever necessary.
- Switch the appliance off when it is not in use.

Caution!

Residual risks

Even if you use this electric power tool in accordance with instructions, certain residual risks cannot be ruled out. The following hazards may arise in connection with the equipment's construction and layout:

1. Lung damage if no suitable protective dust mask is used.
2. Damage to hearing if no suitable ear protection is used.

Danger!

The electric power tool generates an electromagnetic field during operation. Under certain circumstances this field may actively or passively impede medical implants. To reduce the risk of serious or fatal injuries, we recommend persons with medical implants to consult their doctor and the manufacturer of the medical implant prior to using the equipment.

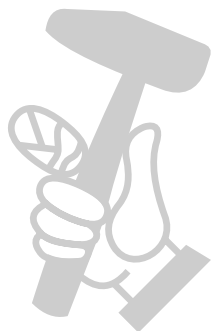

5. Before starting the equipment

This product is supplied without batteries and without a charger and is allowed to be used only with the lithium-ion batteries of the Power-X-Change series!

5.1 Charging the lithium-ion battery pack (Fig. 3.4)

1. Pull the battery pack out of the handle, pressing the pushlock button (C) downwards while you do so.
2. Check that your mains voltage is the same as that marked on the rating plate. Insert the power plug of the charger into the socket outlet. The green LED will begin to blink.
3. Push the battery pack onto the battery charger.

In the section entitled „Charger indicator“ you will find a table with an explanation of the LED indicator on the charger.

If the battery pack fails to charge, check for the following:

- Is there voltage at the power socket
- Is there good contact at the charger's charging contacts

If the battery pack still fails to charge, please send

- the charger and charging adapter
 - and the battery pack
- to our customer service center.

To ensure that items are properly packaged and delivered when you send them to us, please contact our customer service or the point of sale at which the equipment was purchased.

When shipping or disposing of batteries and cordless tools, always ensure that they are packed individually in plastic bags to prevent short circuits and fires.

To ensure that the battery pack provides long service, you should take care to recharge it promptly. You must recharge the battery pack when you notice that the performance of the device drops. Never allow the battery pack to become fully discharged. This will cause it to develop a defect.

5.2 Battery capacity indicator (Fig. 5)

Press the button for the battery capacity indicator

(A). The battery capacity indicator (B) shows the charge status of the battery using 3 LEDs.

All 3 LEDs are lit:

The battery is fully charged.

2 or 1 LED(s) are lit:

The battery has an adequate remaining charge.

1 LED flashes:

The battery is empty, recharge the battery.

All LEDs blink:

The battery temperature is too low. Remove the battery from the equipment, keep it at room temperature for one day. If the fault reoccurs, this means that the rechargeable battery has undergone exhaustive discharge and is defective. Remove the battery from the equipment. Never use or charge a defective battery.

5.3 Fitting a battery (Fig. 3)

Push the battery into the battery mount provided. When the battery is positioned as in Fig. 3, make sure that the pushlock button (C) latches in place! To remove the battery, proceed as described in section 5.1.

6. Operation

Warning!

- The equipment does not have an automatic cut-out. You must therefore monitor the complete inflation and deflation process.
- Do not exceed the inflation pressure recommended by the manufacturer in any circumstances. If inflated objects burst they can cause serious injuries.
- Never insert any objects in the blow connector or the suction connector. Do not cover the air openings.
- Never direct the air outlet towards eyes while the equipment is working.
- To prevent overheating, allow the equipment to cool down after every 20 minutes of operation.
- In the event of overloading, switch off the equipment immediately and allow it to cool.

6.1 Switching on and off (Fig. 1)

- To activate the equipment briefly, press and hold the switch (Item 5) lightly.
- Press the switch (Item 5) to switch on the

equipment. The switch will latch in place and does not need to be held.

- To switch off, press the switch (Item 5) again.

6.2 LED light (Fig. 1)

The LED lamp (Item 6) can illuminate the work area in poor lighting conditions. It lights up automatically when the equipment is switched on, and it continues to shine for a few seconds when the equipment is switched off.

6.3 Inflating (Fig. 6/7)

Use the enclosed adapters if necessary.

- Plug the large adapter (Item 3) onto the blow connector (Item 2) and turn it to the left until it locks in place.
- Plug the small adapter (Item 4) onto the already mounted large adapter if needed.

6.4 Deflating (Fig. 8)

Use one or, if necessary, both of the enclosed adapters as shown.

Note:

To avoid problems during inflation or deflation, make sure when you insert the small adapter into standard valves that the usually existing non-return valve (valve flap) is open. This can be opened slightly by gently squeezing the valve together.

7. Cleaning, maintenance and ordering of spare parts

Danger!

Always pull out the mains power plug before starting any cleaning work.

7.1 Cleaning

- Keep all safety devices, air vents and the motor housing free of dirt and dust as far as possible. Wipe the equipment with a clean cloth or blow it with compressed air at low pressure.
- We recommend that you clean the device immediately each time you have finished using it.
- Clean the equipment regularly with a moist cloth and some soft soap. Do not use cleaning agents or solvents; these could attack the plastic parts of the equipment. Ensure that no water can seep into the device. The ingress of water into an electric tool increases the risk of an electric shock.

7.2 Maintenance

There are no parts inside the equipment which require additional maintenance.

7.3 Ordering replacement parts:

Please quote the following data when ordering replacement parts:

- Type of machine
 - Article number of the machine
 - Identification number of the machine
 - Replacement part number of the part required
- For our latest prices and information please go to www.Einhell-Service.com

8. Disposal and recycling

The equipment is supplied in packaging to prevent it from being damaged in transit. The raw materials in this packaging can be reused or recycled. The equipment and its accessories are made of various types of material, such as metal and plastic. Never place defective equipment in your household refuse. The equipment should be taken to a suitable collection center for proper disposal. If you do not know the whereabouts of such a collection point, you should ask in your local council offices.

9. Storage

Store the equipment and accessories in a dark and dry place at above freezing temperature. The ideal storage temperature is between 5 and 30 °C. Store the electric tool in its original packaging.

10. Charger indicator

Indicator status		Explanations and actions
Red LED	Green LED	
Off	Flashing	<p>Ready for use The charger is connected to the mains and is ready for use; there is no battery pack in the charger</p>
On	Off	<p>Charging The charger is charging the battery pack in quick charge mode. The charging times are shown directly on the charger. Important! The actual charging times may vary slightly from the stated charging times depending on the existing battery charge.</p>
Off	On	<p>The battery is charged and ready for use. The unit then changes over to gentle charging mode until the battery is fully charged. To do this, leave the rechargeable battery on the charger for approx. 15 minutes longer. Action: Take the battery pack out of the charger. Disconnect the charger from the mains supply.</p>
Flashing	Off	<p>Adapted charging The charger is in gentle charging mode. For safety reasons the charging is performed less quickly and takes more time. The reasons can be: - The rechargeable battery has not been used for a very long time. - The battery temperature is outside the ideal range. Action: Wait for the charging to be completed; you can still continue to charge the battery pack.</p>
Flashing	Flashing	<p>Fault Charging is no longer possible. The battery pack is defective. Action: Never charge a defective battery pack. Take the battery pack out of the charger.</p>
On	On	<p>Temperature fault The battery pack is too hot (e.g. due to direct sunshine) or too cold (below 0° C). Action: Remove the battery pack and keep it at room temperature (approx. 20° C) for one day .</p>



For EU countries only

Never place any electric power tools in your household refuse.

To comply with European Directive 2012/19/EC concerning old electric and electronic equipment and its implementation in national laws, old electric power tools have to be separated from other waste and disposed of in an environment-friendly fashion, e.g. by taking to a recycling depot.

Recycling alternative to the return request:

As an alternative to returning the equipment to the manufacturer, the owner of the electrical equipment must make sure that the equipment is properly disposed of if he no longer wants to keep the equipment. The old equipment can be returned to a suitable collection point that will dispose of the equipment in accordance with the national recycling and waste disposal regulations. This does not apply to any accessories or aids without electrical components supplied with the old equipment.

The reprinting or reproduction by any other means, in whole or in part, of documentation and papers accompanying products is permitted only with the express consent of the Einhell Germany AG.

Subject to technical changes

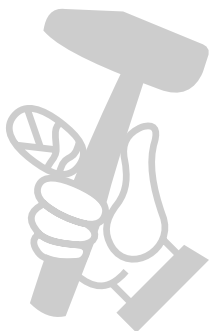

Service information

We have competent service partners in all countries named on the guarantee certificate whose contact details can also be found on the guarantee certificate. These partners will help you with all service requests such as repairs, spare and wearing part orders or the purchase of consumables.

Please note that the following parts of this product are subject to normal or natural wear and that the following parts are therefore also required for use as consumables.

Category	Example
Wear parts*	Battery
Consumables*	
Missing parts	

* Not necessarily included in the scope of delivery!

In the effect of defects or faults, please register the problem on the internet at www.Einhell-Service.com. Please ensure that you provide a precise description of the problem and answer the following questions in all cases:

- Did the equipment work at all or was it defective from the beginning?
- Did you notice anything (symptom or defect) prior to the failure?
- What malfunction does the equipment have in your opinion (main symptom)? Describe this malfunction.

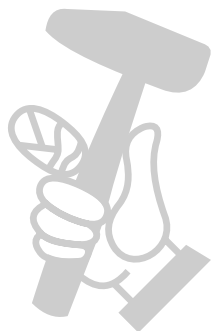

Warranty certificate

Dear Customer,

All of our products undergo strict quality checks to ensure that they reach you in perfect condition. In the unlikely event that your device develops a fault, please contact our service department at the address shown on this guarantee card. You can also contact us by telephone using the service number shown.

Please note the following terms under which guarantee claims can be made:

1. These guarantee terms apply to consumers only, i.e. natural persons intending to use this product neither for their commercial activities nor for any other self-employed activities. These warranty terms regulate additional warranty services, which the manufacturer mentioned below promises to buyers of its new products in addition to their statutory rights of guarantee. Your statutory guarantee claims are not affected by this guarantee. Our guarantee is free of charge to you.
2. The warranty services cover only defects due to material or manufacturing faults on a product which you have bought from the manufacturer mentioned below and are limited to either the rectification of said defects on the product or the replacement of the product, whichever we prefer.
Please note that our devices are not designed for use in commercial, trade or professional applications. A guarantee contract will not be created if the device has been used by commercial, trade or industrial business or has been exposed to similar stresses during the guarantee period.
3. The following are not covered by our guarantee:
 - Damage to the device caused by a failure to follow the assembly instructions or due to incorrect installation, a failure to follow the operating instructions (for example connecting it to an incorrect mains voltage or current type) or a failure to follow the maintenance and safety instructions or by exposing the device to abnormal environmental conditions or by lack of care and maintenance.
 - Damage to the device caused by abuse or incorrect use (for example overloading the device or the use of unapproved tools or accessories), ingress of foreign bodies into the device (such as sand, stones or dust, transport damage), the use of force or damage caused by external forces (for example by dropping it).
 - Damage to the device or parts of the device caused by normal or natural wear or tear or by normal use of the device.
4. The guarantee is valid for a period of 24 months starting from the purchase date of the device. Guarantee claims should be submitted before the end of the guarantee period within two weeks of the defect being noticed. No guarantee claims will be accepted after the end of the guarantee period. The original guarantee period remains applicable to the device even if repairs are carried out or parts are replaced. In such cases, the work performed or parts fitted will not result in an extension of the guarantee period, and no new guarantee will become active for the work performed or parts fitted. This also applies if an on-site service is used.
5. To make a claim under the guarantee, please register the defective device at: www.Einhell-Service.com. Please keep your bill of purchase or other proof of purchase for the new device. Devices that are returned without proof of purchase or without a rating plate shall not be covered by the guarantee, because appropriate identification will not be possible. If the defect is covered by our guarantee, then the item in question will either be repaired immediately and returned to you or we will send you a new replacement.

Of course, we are also happy offer a chargeable repair service for any defects which are not covered by the scope of this guarantee or for units which are no longer covered. To take advantage of this service, please send the device to our service address.

Also refer to the restrictions of this warranty concerning wear parts, consumables and missing parts as set out in the service information in these operating instructions.

