

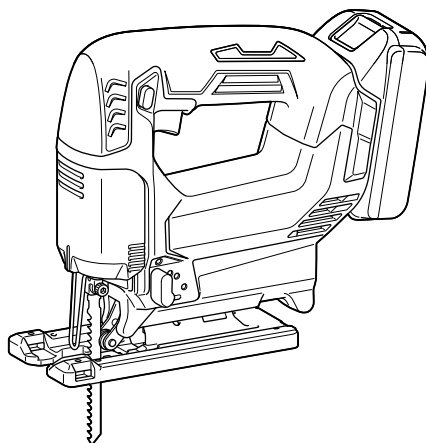

EN	Cordless Jig Saw	INSTRUCTION MANUAL	8
FR	Scie sauteuse sans fil	MANUEL D'INSTRUCTIONS	16
DE	Akku-Stichsäge	BETRIEBSANLEITUNG	25
IT	Seghetto alternativo a batteria	ISTRUZIONI PER L'USO	34
NL	Accudecoupeerzaag	GEbruIKSAANWIJZING	43
ES	Sierra Caladora Inalámbrica	MANUAL DE INSTRUCCIONES	51
PT	Serra Tico-Tico a Bateria	MANUAL DE INSTRUÇÕES	60
EL	Φορητό παλινδρομικό πριόνι	ΕΓΧΕΙΡΙΔΙΟ ΟΔΗΓΙΩΝ	68
TR	Akülü Dekupaj Testere	KULLANMA KILAVUZU	77

DJV186



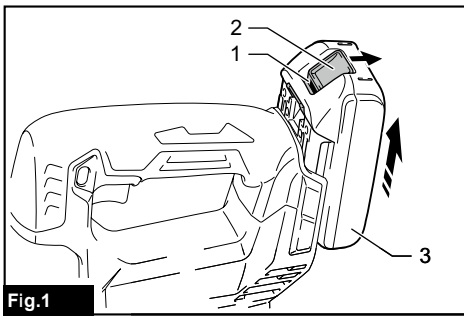

Fig.1

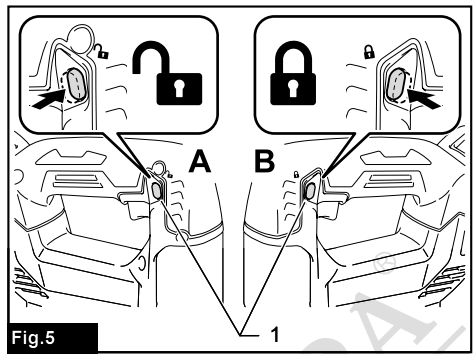

Fig.5

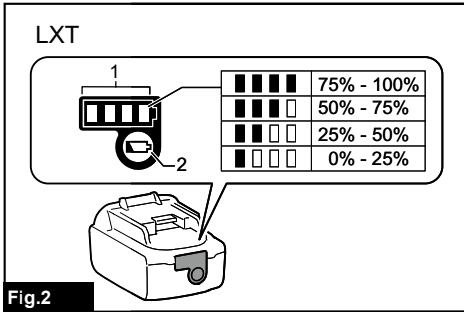

Fig.2

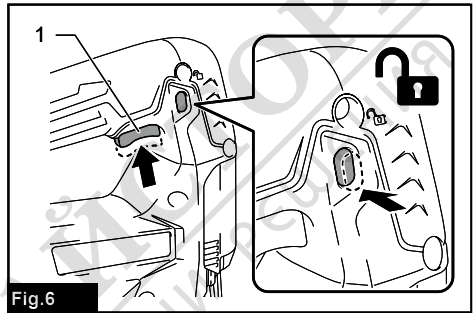

Fig.6

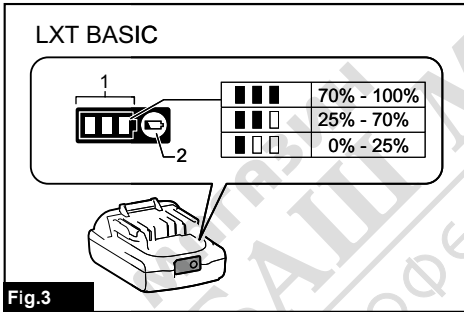

Fig.3

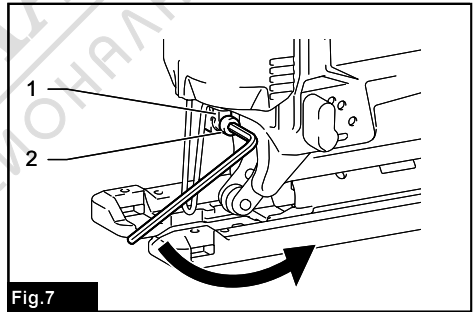

Fig.7

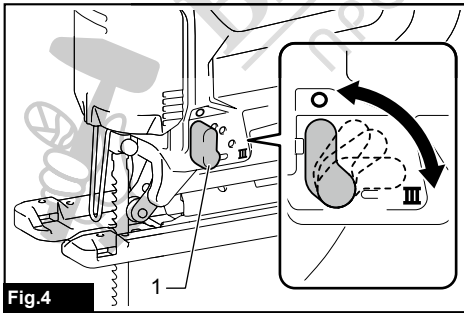

Fig.4

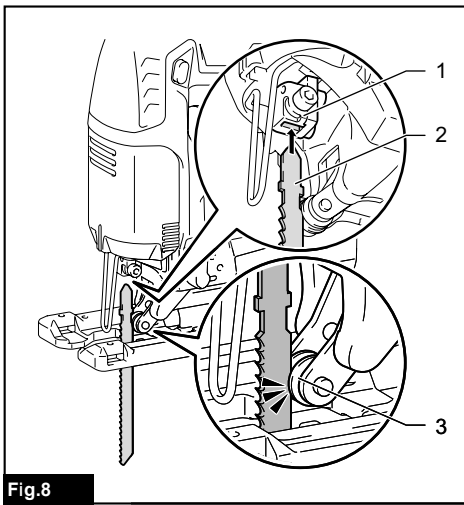

Fig.8

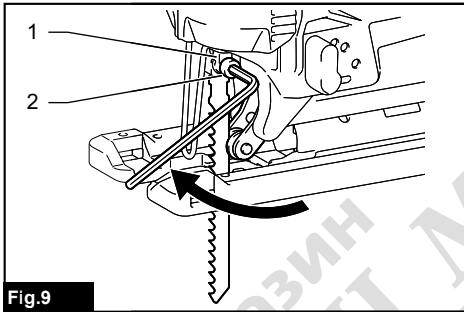

Fig.9

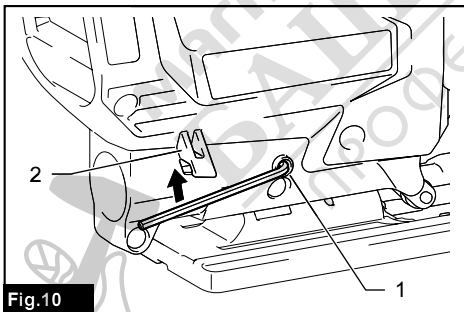

Fig.10

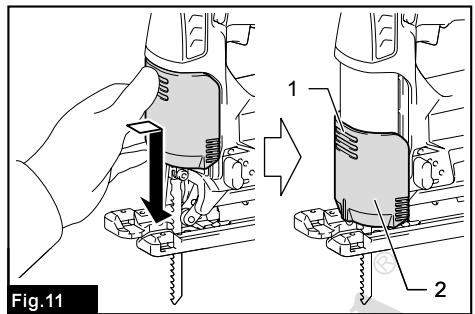

Fig.11

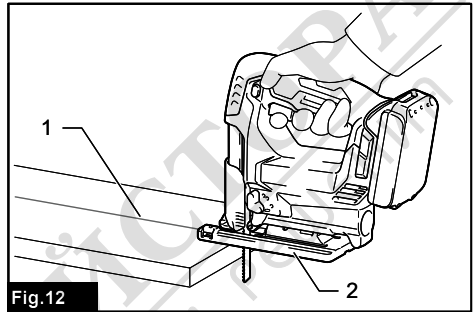

Fig.12

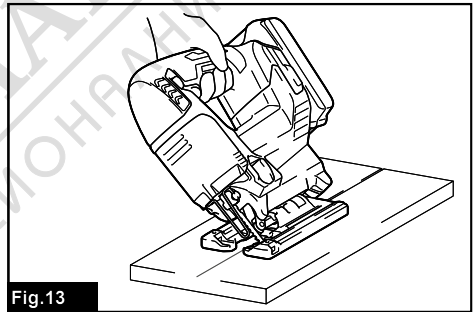

Fig.13

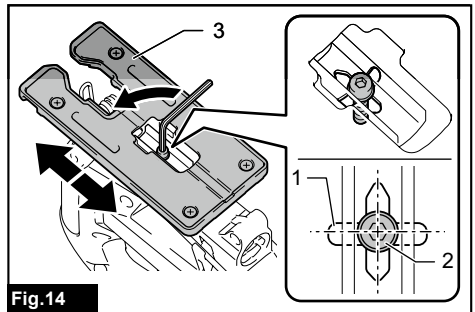
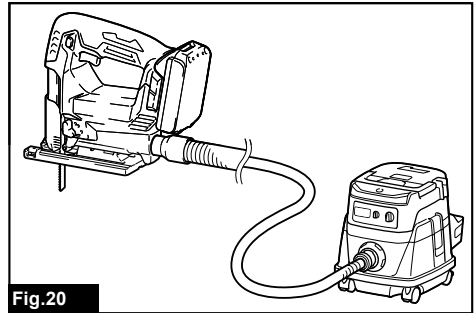
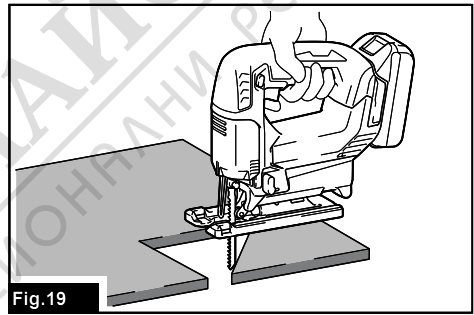
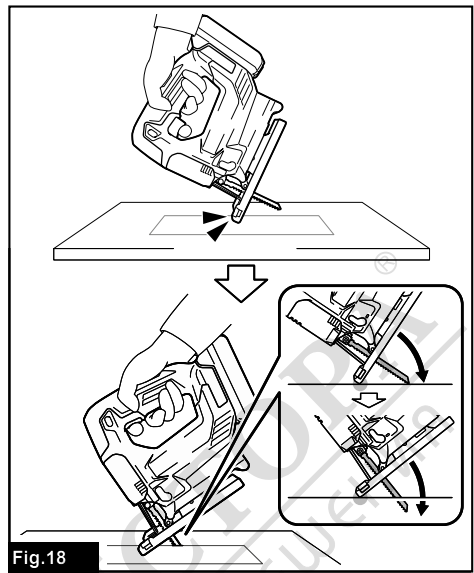
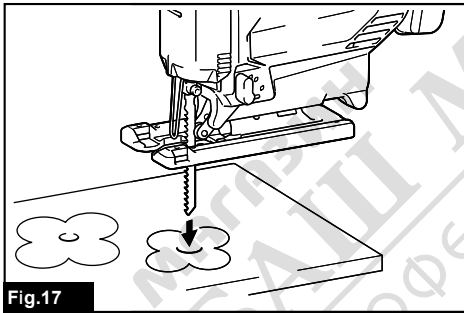
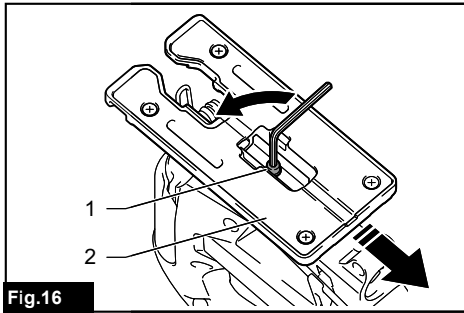
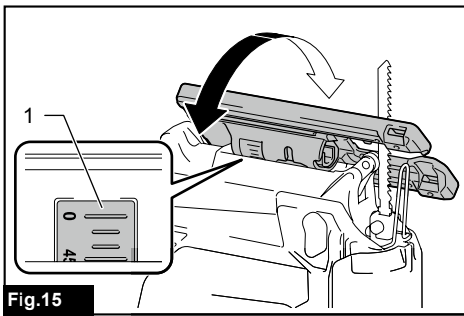

Fig.14



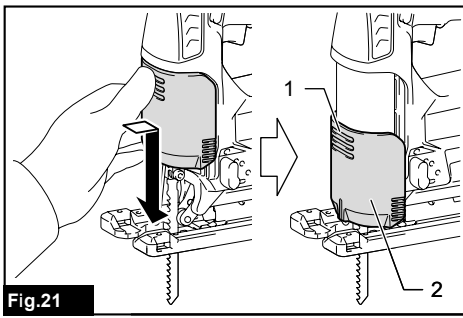

Fig.21

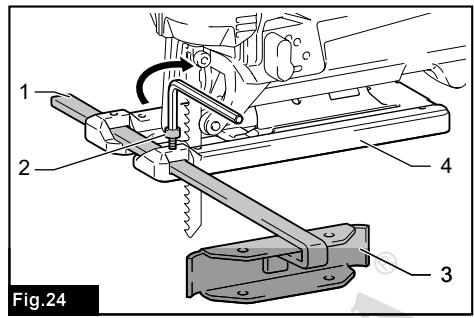

Fig.24

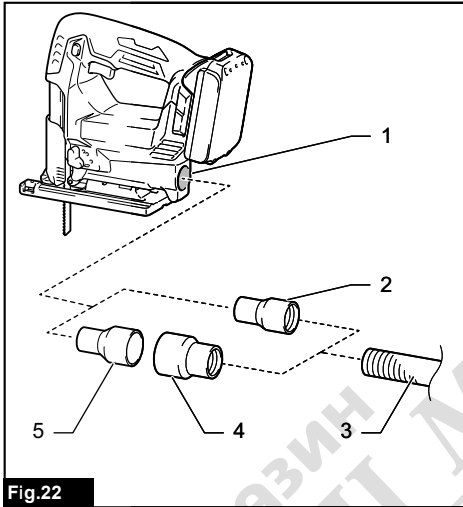

Fig.22

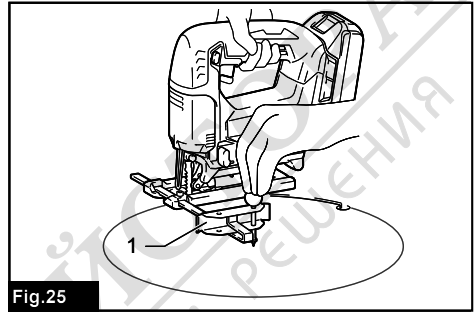

Fig.25

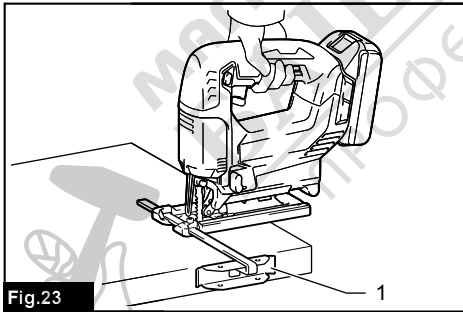

Fig.23

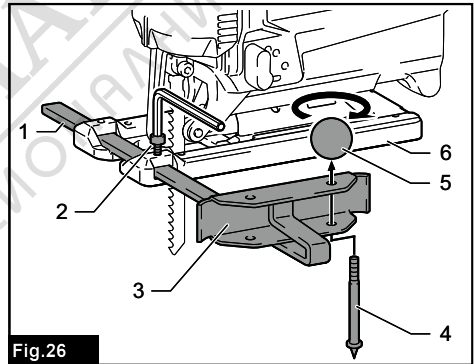

Fig.26

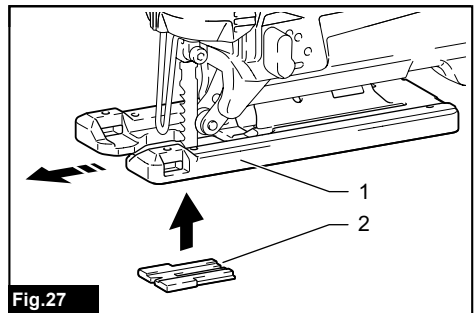
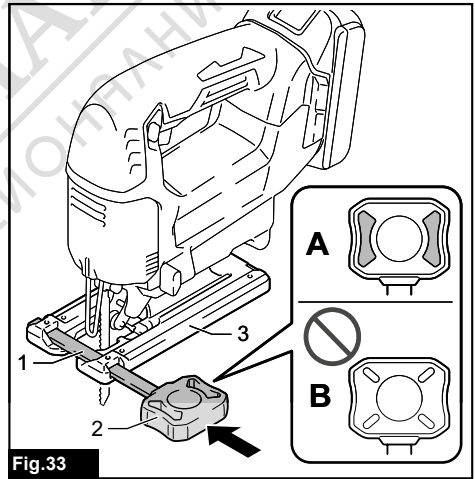
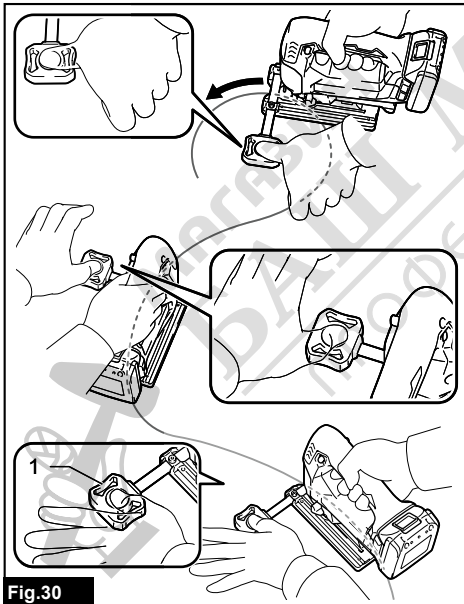
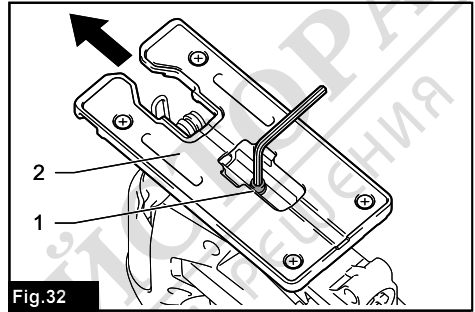
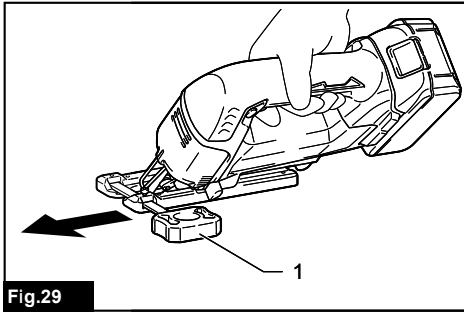
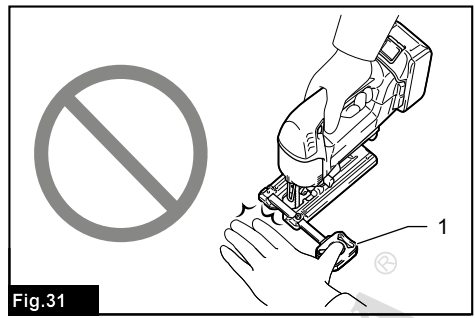
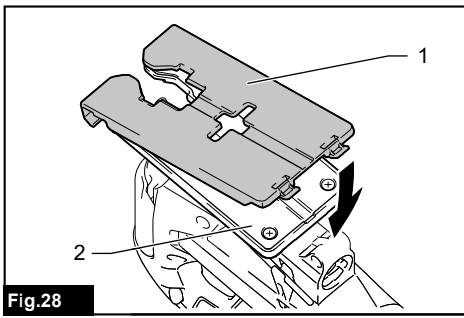

Fig.27



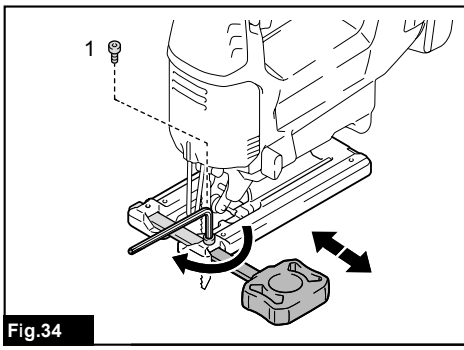

Fig.34

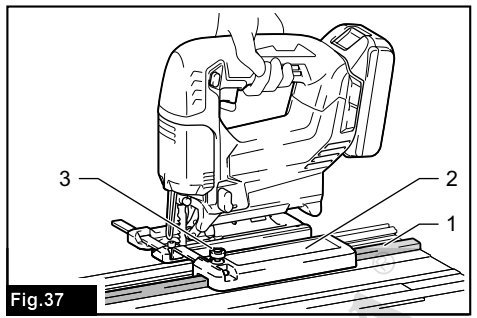

Fig.37

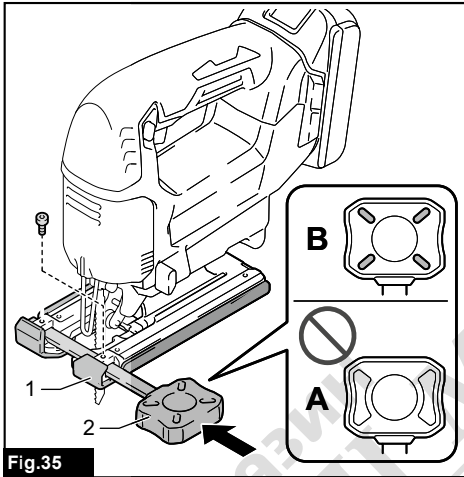

Fig.35

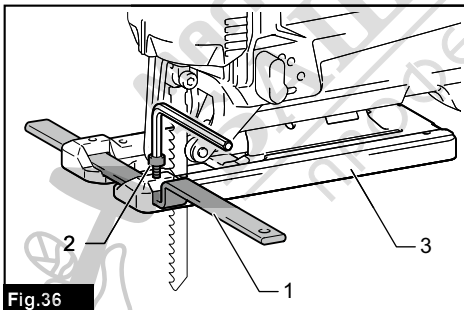

Fig.36

МАЙСТОР
ПРОФЕСІОНАЛНИ РЕШЕННЯ

SPECIFICATIONS

Model:		DJV186
Length of stroke		18 mm
Strokes per minute		0 - 2,900 min ⁻¹
Blade type		B type
Max. cutting capacities	Wood	65 mm
	Mild steel	6 mm
	Aluminum	10 mm
Overall length (with BL1860B)		257 mm
Rated voltage		D.C. 18 V
Net weight		1.9 - 2.2 kg

- Due to our continuing program of research and development, the specifications herein are subject to change without notice.
- Specifications may differ from country to country.
- The weight may differ depending on the attachment(s), including the battery cartridge. The lightest and heaviest combination are shown in the table.

Applicable battery cartridge and charger

	LXT	LXT BASIC
Battery cartridge	BL1815N / BL1820B / BL1830B / BL1840B / BL1850B / BL1860B	BLB182
Charger	DC18RC / DC18RD / DC18RE / DC18SD / DC18SE / DC18SF / DC18SH / DC18WC	DCB18WA

- Some of the battery cartridges and chargers listed above may not be available depending on your region of residence.
- Charge the LXT battery cartridge with the LXT battery charger and the LXT BASIC battery cartridge with the LXT BASIC battery charger.

⚠WARNING: Only use the battery cartridges and chargers listed above. Use of any other battery cartridges and chargers may cause injury and/or fire.

Intended use

The tool is intended for the sawing of wood, plastic and metal materials.

Noise

The typical A-weighted noise level determined according to EN62841-2-11:

Sound pressure level (L_{pA}): 85 dB (A)

Sound power level (L_{wA}): 93 dB (A)

Uncertainty (K): 3 dB (A)

NOTE: The declared noise emission value(s) has been measured in accordance with a standard test method and may be used for comparing one tool with another.

NOTE: The declared noise emission value(s) may also be used in a preliminary assessment of exposure.

⚠WARNING: Wear ear protection.

⚠WARNING: The noise emission during actual use of the power tool can differ from the declared value(s) depending on the ways in which the tool is used especially what kind of workpiece is processed.

⚠WARNING: Be sure to identify safety measures to protect the operator that are based on an estimation of exposure in the actual conditions of use (taking account of all parts of the operating cycle such as the times when the tool is switched off and when it is running idle in addition to the trigger time).

Vibration

The vibration total value (tri-axial vector sum) determined according to EN62841-2-11:

Work mode: cutting boards

Vibration emission (a_{hB}): 7.5 m/s²

Uncertainty (K): 1.5 m/s²

Work mode: cutting sheet metal
Vibration emission ($a_{h,M}$): 4.2 m/s²
Uncertainty (K): 1.5 m/s²

NOTE: The declared vibration total value(s) has been measured in accordance with a standard test method and may be used for comparing one tool with another.

NOTE: The declared vibration total value(s) may also be used in a preliminary assessment of exposure.

⚠WARNING: The vibration emission during actual use of the power tool can differ from the declared value(s) depending on the ways in which the tool is used especially what kind of workpiece is processed.

⚠WARNING: Be sure to identify safety measures to protect the operator that are based on an estimation of exposure in the actual conditions of use (taking account of all parts of the operating cycle such as the times when the tool is switched off and when it is running idle in addition to the trigger time).

Declarations of Conformity

For European countries only

The Declarations of conformity are included in Annex A to this instruction manual.

SAFETY WARNINGS

General power tool safety warnings

⚠WARNING Read all safety warnings, instructions, illustrations and specifications provided with this power tool. Failure to follow all instructions listed below may result in electric shock, fire and/or serious injury.

Save all warnings and instructions for future reference.

The term "power tool" in the warnings refers to your mains-operated (corded) power tool or battery-operated (cordless) power tool.

Cordless jig saw safety warnings

1. **Hold the power tool by insulated gripping surfaces, when performing an operation where the cutting accessory may contact hidden wiring.** Cutting accessory contacting a "live" wire may make exposed metal parts of the power tool "live" and could give the operator an electric shock.
2. **Use clamps or another practical way to secure and support the workpiece to a stable platform.** Holding the workpiece by hand or against your body leaves it unstable and may lead to loss of control.
3. **Always use safety glasses or goggles.** Ordinary eye or sun glasses are NOT safety glasses.

4. **Avoid cutting nails.** Inspect workpiece for any nails and remove them before operation.
5. **Do not cut oversize workpiece.**
6. **Check for the proper clearance around the workpiece before cutting so that the jig saw blade will not strike the floor, workbench, etc.**
7. **Hold the tool firmly.**
8. **Make sure the jig saw blade is not contacting the workpiece before the switch is turned on.**
9. **Keep hands away from moving parts.**
10. **Do not leave the tool running. Operate the tool only when hand-held.**
11. **Always switch off and wait for the jig saw blade to come to a complete stop before removing the jig saw blade from the workpiece.**
12. **Do not touch the jig saw blade or the workpiece immediately after operation; they may be extremely hot and could burn your skin.**
13. **Do not operate the tool at no-load unnecessarily.**
14. **Some material contains chemicals which may be toxic. Take caution to prevent dust inhalation and skin contact. Follow material supplier safety data.**
15. **Always use the correct dust mask/respirator for the material and application you are working with.**

SAVE THESE INSTRUCTIONS.

⚠WARNING: DO NOT let comfort or familiarity with product (gained from repeated use) replace strict adherence to safety rules for the subject product. MISUSE or failure to follow the safety rules stated in this instruction manual may cause serious personal injury.

Important safety instructions for battery cartridge

1. **Before using battery cartridge, read all instructions and cautionary markings on (1) battery charger, (2) battery, and (3) product using battery.**
2. **Do not disassemble or tamper with the battery cartridge.** It may result in a fire, excessive heat, or explosion.
3. **If operating time has become excessively shorter, stop operating immediately.** It may result in a risk of overheating, possible burns and even an explosion.
4. **If electrolyte gets into your eyes, rinse them out with clear water and seek medical attention right away.** It may result in loss of your eyesight.
5. **Do not short the battery cartridge:**
 - (1) **Do not touch the terminals with any conductive material.**
 - (2) **Avoid storing battery cartridge in a container with other metal objects such as nails, coins, etc.**
 - (3) **Do not expose battery cartridge to water or rain.**

A battery short can cause a large current flow, overheating, possible burns and even a breakdown.

6. Do not store and use the tool and battery cartridge in locations where the temperature may reach or exceed 50 °C (122 °F).
7. Do not incinerate the battery cartridge even if it is severely damaged or is completely worn out. The battery cartridge can explode in a fire.
8. Do not nail, cut, crush, throw, drop the battery cartridge, or hit against a hard object to the battery cartridge. Such conduct may result in a fire, excessive heat, or explosion.
9. Do not use a damaged battery.
10. The contained lithium-ion batteries are subject to the Dangerous Goods Legislation requirements.
For commercial transports e.g. by third parties, forwarding agents, special requirement on packaging and labeling must be observed.
For preparation of the item being shipped, consulting an expert for hazardous material is required.
Please also observe possibly more detailed national regulations.
Tape or mask off open contacts and pack up the battery in such a manner that it cannot move around in the packaging.
11. When disposing the battery cartridge, remove it from the tool and dispose of it in a safe place. Follow your local regulations relating to disposal of battery.
12. Use the batteries only with the products specified by Makita. Installing the batteries to non-compliant products may result in a fire, excessive heat, explosion, or leak of electrolyte.
13. If the tool is not used for a long period of time, the battery must be removed from the tool.
14. During and after use, the battery cartridge may take on heat which can cause burns or low temperature burns. Pay attention to the handling of hot battery cartridges.
15. Do not touch the terminal of the tool immediately after use as it may get hot enough to cause burns.
16. Do not allow chips, dust, or soil stuck into the terminals, holes, and grooves of the battery cartridge. It may cause heating, catching fire, burst and malfunction of the tool or battery cartridge, resulting in burns or personal injury.
17. Unless the tool supports the use near high-voltage electrical power lines, do not use the battery cartridge near high-voltage electrical power lines. It may result in a malfunction or breakdown of the tool or battery cartridge.
18. Keep the battery away from children.

SAVE THESE INSTRUCTIONS.

CAUTION: Only use genuine Makita batteries. Use of non-genuine Makita batteries, or batteries that have been altered, may result in the battery bursting causing fires, personal injury and damage. It will also void the Makita warranty for the Makita tool and charger.

Tips for maintaining maximum battery life

1. Charge the battery cartridge before completely discharged. Always stop tool operation and charge the battery cartridge when you notice less tool power.
2. Never recharge a fully charged battery cartridge. Overcharging shortens the battery service life.
3. Charge the battery cartridge with room temperature at 10 °C - 40 °C (50 °F - 104 °F). Let a hot battery cartridge cool down before charging it.
4. When not using the battery cartridge, remove it from the tool or the charger.
5. Charge the battery cartridge if you do not use it for a long period (more than six months).

FUNCTIONAL DESCRIPTION

CAUTION: Always be sure that the tool is switched off and the battery cartridge is removed before adjusting or checking function on the tool.

Installing or removing battery cartridge

CAUTION: Always switch off the tool before installing or removing of the battery cartridge.

CAUTION: Hold the tool and the battery cartridge firmly when installing or removing battery cartridge. Failure to hold the tool and the battery cartridge firmly may cause them to slip off your hands and result in damage to the tool and battery cartridge and a personal injury.

To install the battery cartridge, align the tongue on the battery cartridge with the groove in the housing and slip it into place. Insert it all the way until it locks in place with a little click. If you can see the red indicator as shown in the figure, it is not locked completely.

To remove the battery cartridge, slide it from the tool while sliding the button on the front of the cartridge.

► Fig. 1: 1. Red indicator 2. Button 3. Battery cartridge

CAUTION: Always install the battery cartridge fully until the red indicator cannot be seen. If not, it may accidentally fall out of the tool, causing injury to you or someone around you.

CAUTION: Do not install the battery cartridge forcibly. If the cartridge does not slide in easily, it is not being inserted correctly.

Battery protection system

The battery cartridge is equipped with a battery protection system. This system automatically cuts off power to the motor to extend battery life.

The tool will automatically stop during operation if the tool and/or battery are placed under one of the following conditions:

Overloaded:

The tool is operated in a manner that causes it to draw an abnormally high current.

In this situation, release the switch trigger and stop the application that caused the tool to become overloaded. Then pull the switch trigger again to restart the tool.

If the tool does not start, the battery is overheated.

In this situation, let the battery cool before pulling the switch trigger again.

Low battery voltage:

The remaining battery capacity is too low and the tool will not operate. If you pull the switch trigger, the motor runs again but stops soon. In this situation, recharge the battery.

Indicating the remaining battery capacity



Only for battery cartridges with the indicator

NOTE: Depending on the conditions of use and the ambient temperature, the indication may differ slightly from the actual capacity.

Press the check button on the battery cartridge to indicate the remaining battery capacity. The indicator lamps light up for a few seconds.

► **Fig.2:** 1. Indicator lamps 2. Check button

► **Fig.3:** 1. Indicator lamps 2. Check button

Indicator lamps	Error description
	The battery protection system works. Charge the battery, or check other factors of the battery protection system.
	The battery may have malfunctioned.

Selecting the cutting action

This tool can be operated with an orbital or a straight line (up and down) cutting action. The orbital cutting action thrusts the jig saw blade forward and increases cutting speed.

► **Fig.4:** 1. Cutting action changing lever

To change the cutting action, turn the cutting action changing lever to the desired cutting action position. Refer to the table to select the appropriate cutting action.

Position	Cutting action	Applications
0	Straight line cutting action	For cutting mild steel, stainless steel and plastics.
		For clean cuts in wood and plywood.
I	Small orbital cutting action	For cutting mild steel, aluminum and hard wood.

Position	Cutting action	Applications
II	Medium orbital cutting action	For cutting wood and plywood.
		For fast cutting in aluminum and mild steel.
III	Large orbital cutting action	For fast cutting in wood and plywood.

Switch action

CAUTION: Before installing the battery cartridge into the tool, always check to see that the switch trigger actuates properly and returns to the "OFF" position when released.

CAUTION: When not operating the tool, depress the lock/unlock button from "B" side to lock the switch trigger in the OFF position.

To prevent the switch trigger from accidentally pulled, the lock/unlock button is provided.

To start the tool, depress the lock/unlock button from "A" side and pull the switch trigger.

After use, always press in the lock/unlock button from "B" side to lock the switch trigger.

► **Fig.5:** 1. Lock/unlock button

The tool speed increases as you increase pressure on the switch trigger. Release the switch trigger to stop the tool.

► **Fig.6:** 1. Switch trigger

Electric brake

This tool is equipped with an electric brake. If the tool consistently fails to quickly stop after the switch trigger is released, have the tool serviced at a Makita service center.

ASSEMBLY

CAUTION: Always be sure that the tool is switched off and the battery cartridge is removed before carrying out any work on the tool.

Installing and removing jig saw blade

CAUTION: Always clean out all chips or foreign matter adhering to the jig saw blade and/or blade holder. Failure to do so may cause insufficient tightening of the jig saw blade, resulting in a serious personal injury.

CAUTION: Do not touch the jig saw blade or the workpiece immediately after operation. They may be extremely hot and could burn your skin.

CAUTION: Always secure the jig saw blade firmly. Insufficient tightening of the jig saw blade may cause the blade breakage or serious personal injury.

CAUTION: Use only B type jig saw blades. Using blades other than B type causes insufficient tightening of the jig saw blade, resulting in a serious personal injury.

CAUTION: When you remove the jig saw blade, be careful not to hurt your fingers with the top of the jig saw blade or the tips of workpiece.

1. Loosen the bolt on the jig saw blade holder counterclockwise with the hex wrench.
► Fig.7: 1. Jig saw blade holder 2. Bolt

2. Insert the jig saw blade, with the blade teeth facing forward, into the jig saw blade holder as far as it will go.
► Fig.8: 1. Jig saw blade holder 2. Jig saw blade 3. Roller

NOTICE: Make sure that the back edge of the jig saw blade fits into the roller.

3. Tighten the bolt clockwise to secure the jig saw blade.
► Fig.9: 1. Jig saw blade holder 2. Bolt

NOTICE: Pull the jig saw blade lightly to make sure that the jig saw blade will not fall off during operation.

To remove the jig saw blade, follow the installation procedure in reverse.

NOTE: Occasionally lubricate the roller.

Hex wrench storage

When not in use, store the hex wrench as shown in the figure to keep it from being lost.

Insert the short arm of the hex wrench into the storage hole. Then push the long arm of the hex wrench up to the hook until it locks into place.

► Fig.10: 1. Storage hole 2. Hook

Dust cover

CAUTION: Always wear safety goggles when operating the tool with the dust cover lowered.

NOTICE: Raise the dust cover up all the way when performing bevel cuts.

Lower the dust cover to prevent chips from flying during operation.

► Fig.11: 1. Finger rest 2. Dust cover

NOTE: Gently apply pressure on the finger rest with your thumb or finger while sliding the dust cover down or back up.

OPERATION

CAUTION: Hold the tool firmly so that the jig saw base sits evenly on the workpiece without leaning. Failure to do so may cause blade breakage, resulting in a serious injury.

CAUTION: Feed the jig saw through the workpiece very slowly when cutting curves and non-straight lines. Forcing the tool may cause a tilted cutting surface and jig saw blade breakage.

Turn the tool on without the jig saw blade making any contact. Wait until the jig saw blade attains full speed. Then put the jig saw base flat on the workpiece and gently move the tool forward along the previously marked cutting line.

► Fig.12: 1. Cutting line 2. Jig saw base

Bevel cutting

CAUTION: Always be sure that the tool is switched off and the battery cartridge is removed before tilting the base.

NOTICE: Raise the dust cover up all the way when performing bevel cuts.

The jig saw base can be tilted to either side (left or right) at any angle between 0° and 45°, allowing you to make bevel (angled) cuts.

► Fig.13

1. Use the supplied hex wrench to loosen the retaining bolt that secures the jig saw base into its default perpendicular position.

2. Move the jig saw base back or forward so that the retaining bolt is positioned at the center of the cross-shaped bevel slot in the base.

► Fig.14: 1. Bevel slot 2. Retaining bolt 3. Jig saw base

3. Tilt the jig saw base to the angle you require.

► Fig.15: 1. Angle scale

NOTE: Refer to the angle scales on the jig saw base to set your desired bevel angle accurately.

4. Tighten the retaining bolt firmly to secure the jig saw base at an angle.

Front flush cuts

Loosen the retaining bolt that secures the jig saw base using the supplied hex wrench.

Slide the jig saw base all the way back.

Then tighten the retaining bolt firmly to secure the jig saw base in position.

► Fig.16: 1. Retaining bolt 2. Jig saw base

Cutouts

Cutouts can be made with either of two methods: "Boring a starting hole" or "Plunge cutting".

Boring a starting hole

For internal cutouts without a lead-in cut from an edge, pre-drill a starting hole 12 mm or more in diameter. Insert the jig saw blade into the starting hole to start your cut.

► Fig.17

Plunge cutting

You need not bore a starting hole or make a lead-in cut if you carefully do as follows.

1. Touch the front edge of the jig saw base to the workpiece. Tilt the tool so that the tip of the jig saw blade points at your cutting line on the workpiece surface.
2. Holding the tool position against the workpiece, squeeze the switch trigger.
3. Carefully lower the back end of the jig saw base onto the workpiece surface so that the jig saw blade gradually pierces the workpiece.

NOTE: Once the jig saw blade has passed through the workpiece, place the jig saw base flat on the workpiece surface.

4. Start to follow your marked cutting line.
- Fig.18

Finishing edges

To trim edges or make dimensional adjustments, run the jig saw blade lightly along the cut edges.

► Fig.19

Metal cutting

Always use a suitable coolant (cutting oil) when cutting metal. Failure to do so will cause significant jig saw blade wear. The underside of the workpiece can be greased instead of using a coolant.

Dust extraction

NOTICE: Dust extraction cannot be performed when you make bevel cuts.

Set up a dust extraction for your jig saw. Clean cutting operations can be performed by connecting a Makita vacuum cleaner to your tool.

► Fig.20

1. Lower the dust cover before operation.
- Fig.21: 1. Finger rest 2. Dust cover

NOTE: Gently apply pressure on the finger rest with your thumb or finger while sliding the dust cover down or back up.

2. Insert the vacuum hose end into the fitting hole at the rear of the tool using a front cuffs 22.

► Fig.22: 1. Fitting hole 2. Front cuffs 22 3. Vacuum hose 4. Front cuffs 38 5. Joint 22-38

NOTE: Prepare a joint 22-38 if your vacuum hose end is coupled with a front cuffs 38.

Rip fence

Optional accessory

CAUTION: Always be sure that the tool is switched off and the battery cartridge is removed before installing or removing accessories.

Straight cuts

Use the rip fence (guide rule) to assure fast, clean, straight cuts. The attachment helps you cut the workpiece efficiently into pieces in width of 160 mm or less and achieve the desired precision with ease.

► Fig.23: 1. Rip fence (Guide rule)

Insert the guide arm of the rip fence into the square hole of the jig saw base with the rip fence positioned lower than the base plate.

Slide the rip fence to the desired cutting width, then tighten the bolt to secure the position.

► Fig.24: 1. Guide arm 2. Bolt 3. Rip fence (Guide rule) 4. Base plate

Circular cuts

Use the rip fence (guide rule) with the circular guide pin as a circle cutting device. You can cut circles or arcs of 170 mm or less in radius.

► Fig.25: 1. Rip fence (Guide rule)

CAUTION: Do not touch the tip of the circular guide pin. The sharp tip of the circular guide pin can cause injury.

1. Insert the guide arm of the rip fence into the square hole of the jig saw base with the rip fence positioned higher than the base plate.

2. Insert the circular guide pin through either of the two holes in the rip fence from bottom to top.

3. Screw the threaded knob onto the circular guide pin to secure the pin to the rip fence.

► Fig.26: 1. Guide arm 2. Bolt 3. Rip fence (Guide rule) 4. Circular guide pin 5. Threaded knob 6. Base plate

4. Slide the rip fence to the desired cutting radius, then tighten the bolt to secure the position.

NOTE: Always use jig saw blades No. B-17, B-18, B-26 or B-27 when cutting circles or arcs.

Anti-splintering device

Optional accessory

CAUTION: The anti-splintering device cannot be used when you make bevel cuts.

Install the anti-splintering device for splinter-free cuts. Move the jig saw base all the way forward and attach the anti-splintering device from the bottom side of the base.

► Fig.27: 1. Jig saw base 2. Anti-splintering device

NOTE: When you use the cover plate, install the anti-splintering device onto the cover plate.

Cover plate

Optional accessory

Attach the cover plate onto the jig saw base when cutting decorative veneers, plastics, etc. It protects sensitive or delicate surfaces from damage.

Place the cover plate over the base plate. Push fit the cover plate evenly into place.

► **Fig.28:** 1. Cover plate 2. Base plate

Support base

Optional accessory

The use of support base allows for more stable cutting conditions, providing optimal tool performance on bevel cuts and curved cuts.

The support base helps the jig saw base not to tilt in one direction or the other.

► **Fig.29:** 1. Support base

NOTE: Finely adjust the arm length of the support base to offset the weight balance.

Effectively control the position and direction of the support base so that you can perform a series of skillful maneuvers along the intended cutting lines.

► **Fig.30:** 1. Base anchor

CAUTION: Safely hold the base anchor with your fingers. Press and hold your finger on the base anchor to keep the base anchor staying on the workpiece surface.

CAUTION: Pay due attention not to slide your hands out of the correct position and not to slip your hand under the base during cutting operation. Doing otherwise may cause personal injury.

CAUTION: Be careful not to place your hand too close to the jig saw blade and in the path of the blade.

► **Fig.31:** 1. Base anchor

1. Loosen the retaining bolt that secures the jig saw base using the supplied hex wrench. Slide the jig saw base all the way forward. Then tighten the retaining bolt to secure the jig saw base.

► **Fig.32:** 1. Retaining bolt 2. Jig saw base

2. Insert the guide arm of the support base into the square hole of the jig saw base with the "A" side of the base anchor facing upward as shown in the figure.

► **Fig.33:** 1. Guide arm 2. Base anchor 3. Jig saw base

3. Slide the support base to the desired length, then tighten the bolt M4 x 8 to secure the support base.

► **Fig.34:** 1. Bolt M4 x 8

NOTICE: When you use the support base with the optional cover plate, install the support base with the "B" side of the base anchor facing upward as shown in the figure. It otherwise causes a misalignment between the base anchor and the workpiece surface.

► **Fig.35:** 1. Cover plate 2. Base anchor

Guide rail adapter set

Optional accessory

Use the guide rail and guide rail adapter to assure fast, clean, straight cuts. The accessories help you cut the workpiece efficiently in uniform sized pieces and achieve enhanced precision and accuracy.

Insert the guide arm into the square hole of the jig saw base as far as it goes. Tighten the bolt to secure the guide arm as shown in the figure.

► **Fig.36:** 1. Guide arm 2. Bolt 3. Jig saw base

Attach the guide rail adapter to the tool by passing the other end of the guide arm through a square hole in the guide rail adapter. Tighten the bolt to secure the guide rail adapter.

You can perform straight cutting by tracking the guide rail adapter on the guide rail.

► **Fig.37:** 1. Guide rail 2. Guide rail adapter 3. Bolt

NOTICE: Always use jig saw blades No. B-8, B-13, B-16, B-17 or 58 when using the guide rail and the guide rail adapter.

MAINTENANCE

CAUTION: Always be sure that the tool is switched off and the battery cartridge is removed before attempting to perform inspection or maintenance.

NOTICE: Never use gasoline, benzine, thinner, alcohol or the like. Discoloration, deformation or cracks may result.

To maintain product SAFETY and RELIABILITY, repairs, any other maintenance or adjustment should be performed by Makita Authorized or Factory Service Centers, always using Makita replacement parts.

OPTIONAL ACCESSORIES

CAUTION: These accessories or attachments are recommended for use with your Makita tool specified in this manual. The use of any other accessories or attachments might present a risk of injury to persons. Only use accessory or attachment for its stated purpose.

If you need any assistance for more details regarding these accessories, ask your local Makita Service

Center.

- Jig saw blades
- Rip fence (guide rule) set
- Guide rail adapter set
- Anti-splintering device
- Cover plate
- Support base
- Hose set (28 mm, for vacuum cleaner)
- Makita genuine battery and charger

NOTE: Some items in the list may be included in the tool package as standard accessories. They may differ from country to country.



МАГАЗИН
БАШ МАЙСТОРА®
ПРОФЕСИОНАЛНИ РЕШЕНИЯ