

D	Originalbetriebsanleitung Akku-Zug-Kapp-Gehrungssäge	SLO	Originalna navodila za uporabo Akumulatorska dvoročna, čelična, zajeralna žaga
GB	Original operating instructions Cordless drag, crosscut and miter saw	H	Eredeti használati utasítás Akkus vonó-fejező-gérvágó fűrész
F	Instructions d'origine Scie à onglet radiale sans fil	RO	Instrucțiuni de utilizare originale Ferăstrău joagăr, de rețezat și îmbinat la colț cu acumulator
I	Istruzioni per l'uso originali Troncatrice radiale a batteria	GR	Πρωτότυπες Οδηγίες χρήσης Φαλτσοπριονο μπαταρίας
DK/ N	Original betjeningsvejledning Akkudrevet skør-/kap-/geringssav	P	Manual de instrucções original Serra de tração, corte transversal e meia-esquadria sem fio
S	Original-bruksanvisning Batteridrivnen drag-, kap- och geringssåg	HR/ BIH	Originalne upute za uporabu Akumulatorska kružna pila za prorezivanje i koso rezanje
CZ	Originální návod k obsluze Akumulátorová kapovací a pokosová pila s pojezdem	RS	Originalna uputstva za upotrebu Akumulatorska kružna testera za prorezivanje i koso rezanje
SK	Originálny návod na obsluhu Akumulátorová tesárska kapovacia a pokosová píla	PL	Instrukcja oryginalną Akumulatorowa piła ukośna
NL	Originele handleiding Accu trek-kap-verstekzaag	TR	Orijinal Kullanma Talimatı Akülü gönye kesme
E	Manual de instrucciones original Sierra inalámbrica de tracción, oscilante y para cortar ingletes	EE	Originaalkasutusjuhend Akuga nurga- ja järkamissaag
FIN	Alkuperäiskäyttöohje Akku-veto-katkaisujirrisaha		

13



Art.-Nr.: 43.008.85

I.-Nr.: 21011

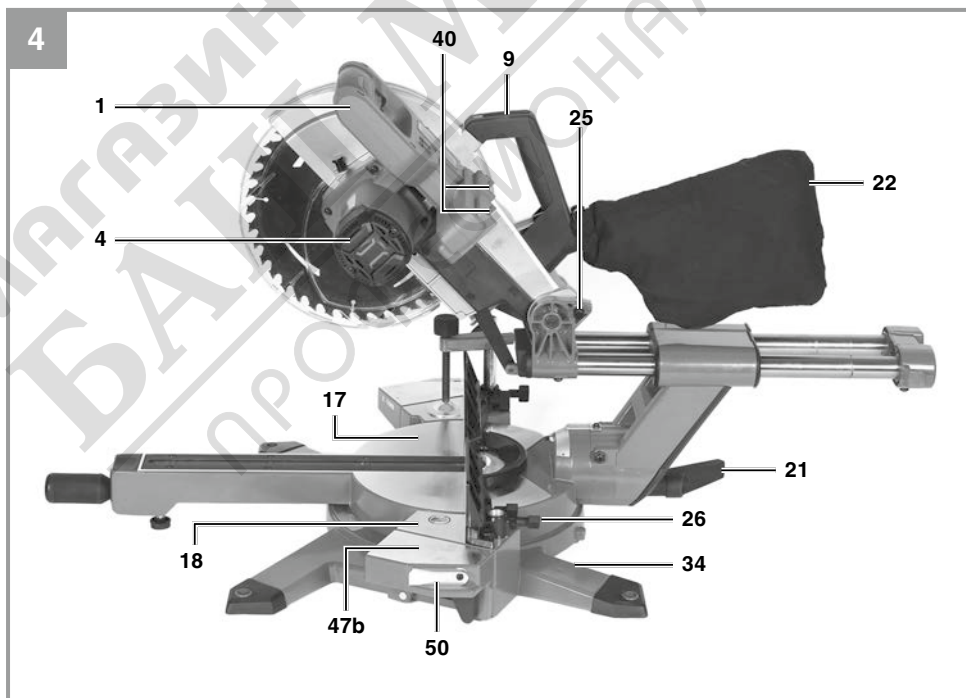
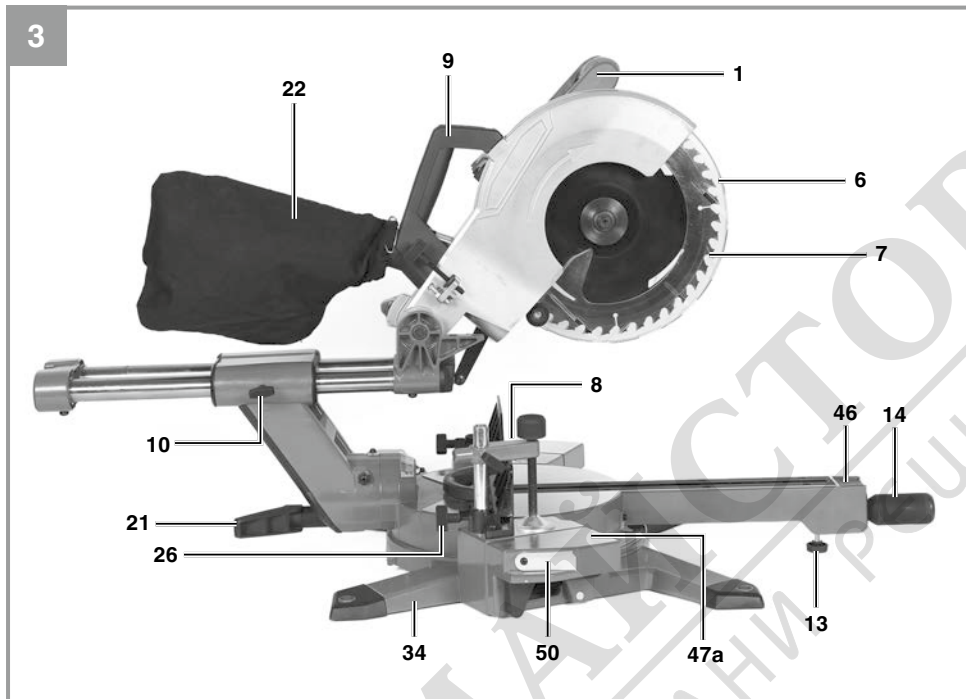

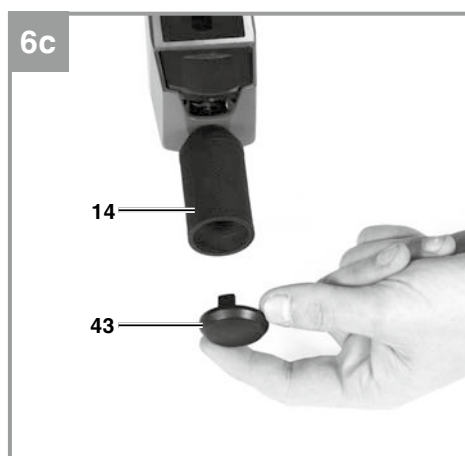
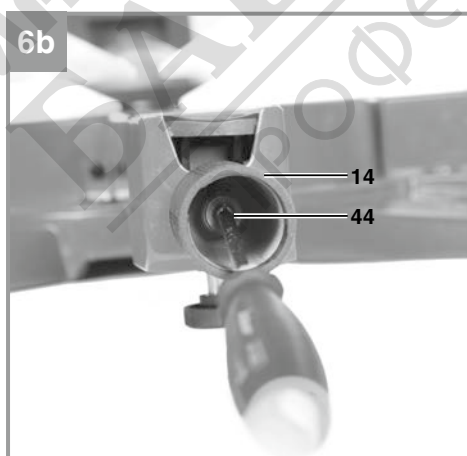
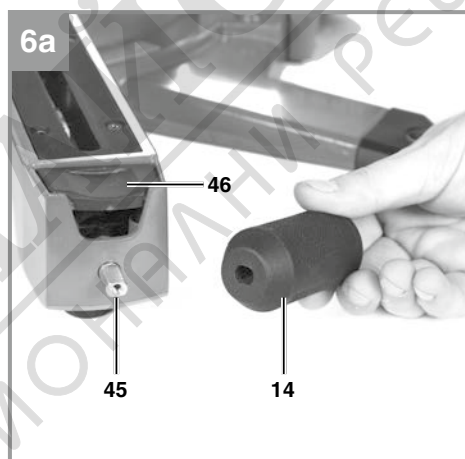
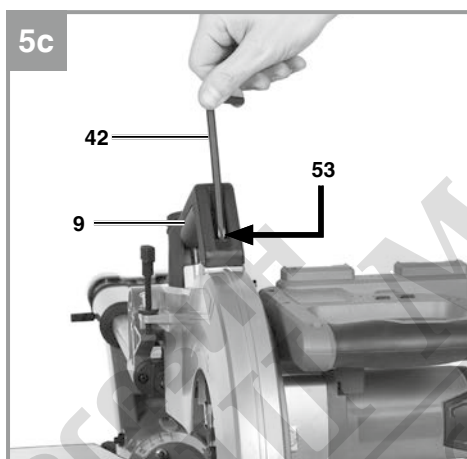
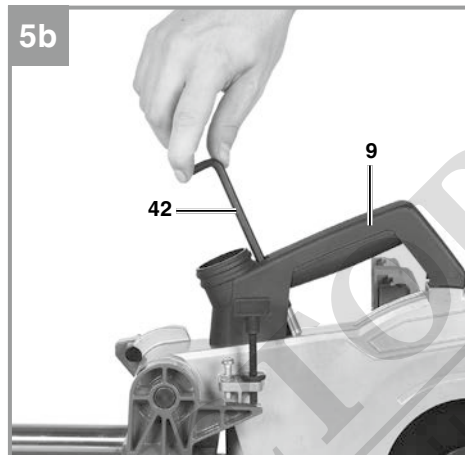
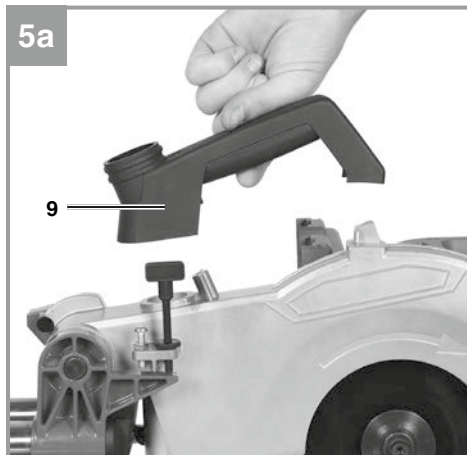

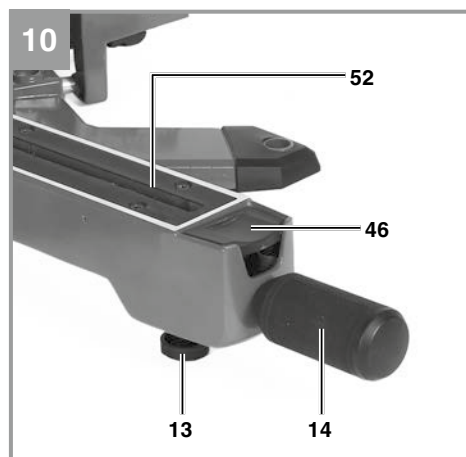
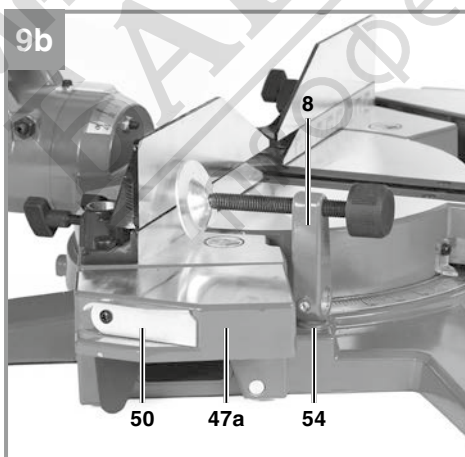
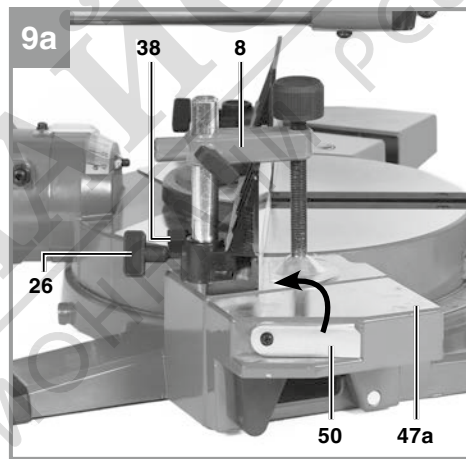
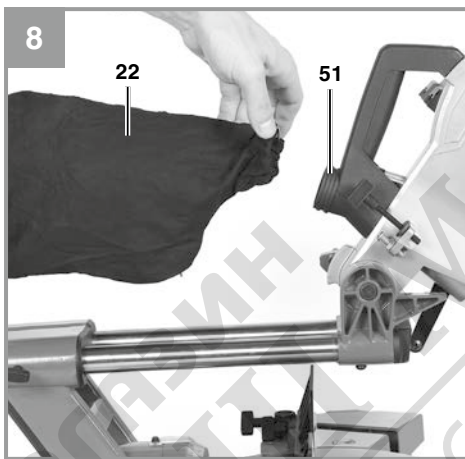
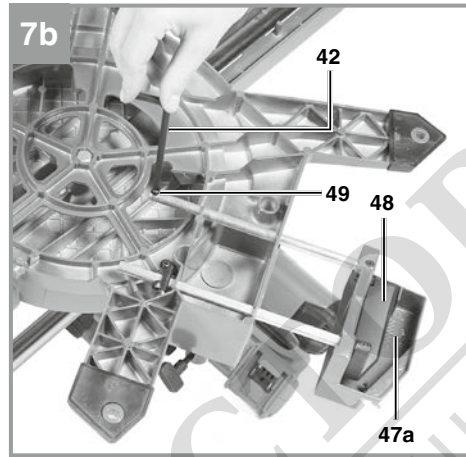
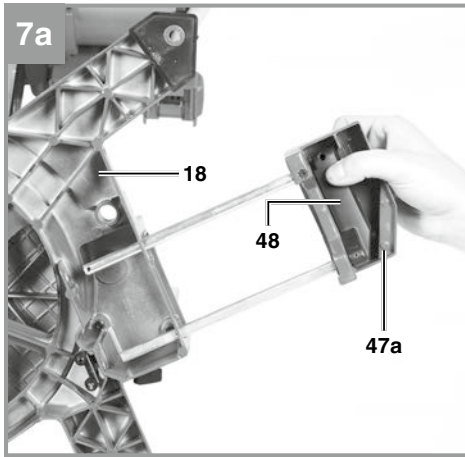

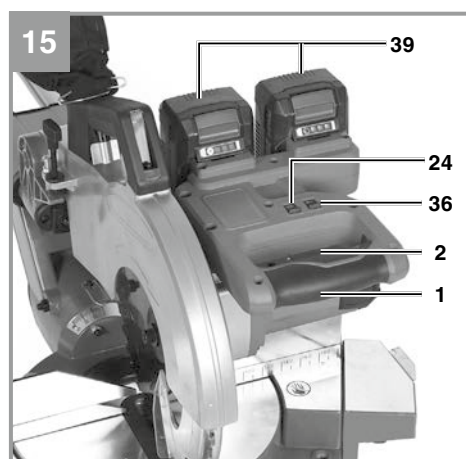
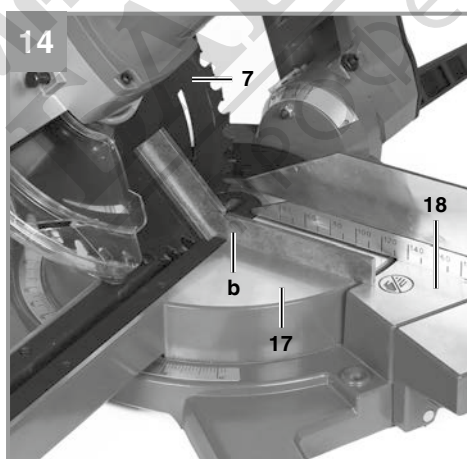
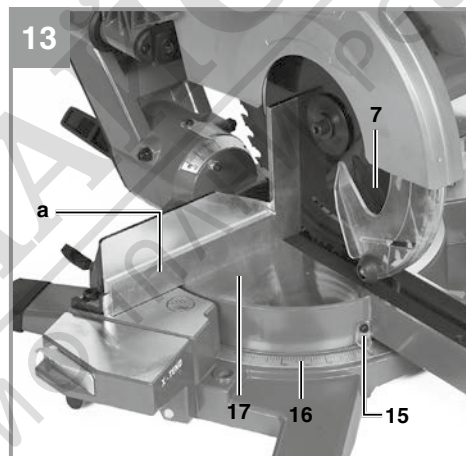
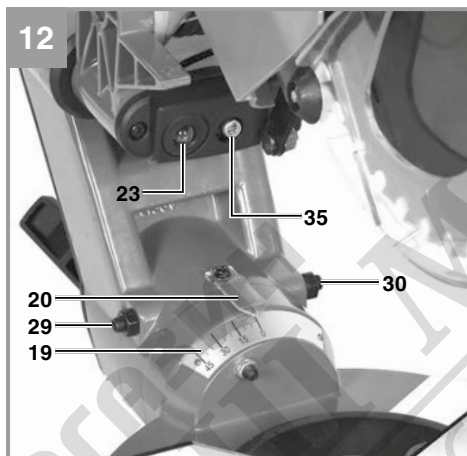
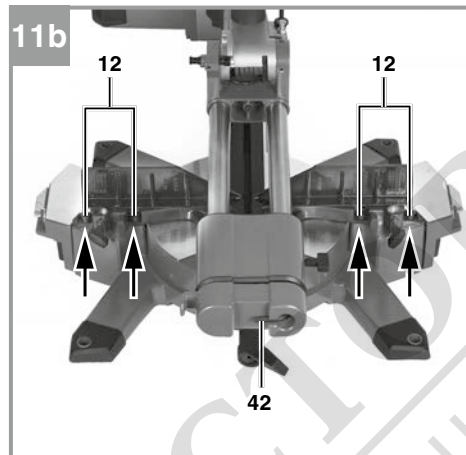
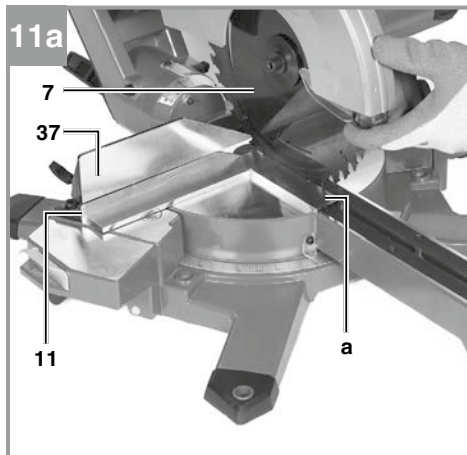

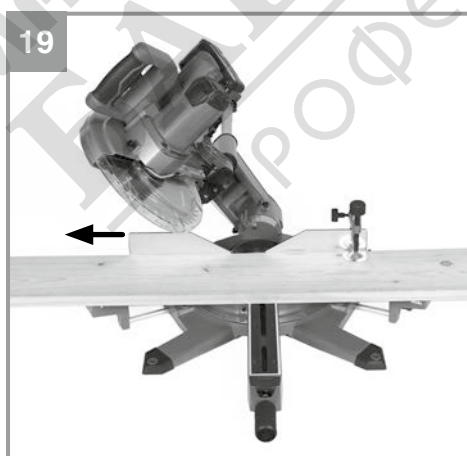
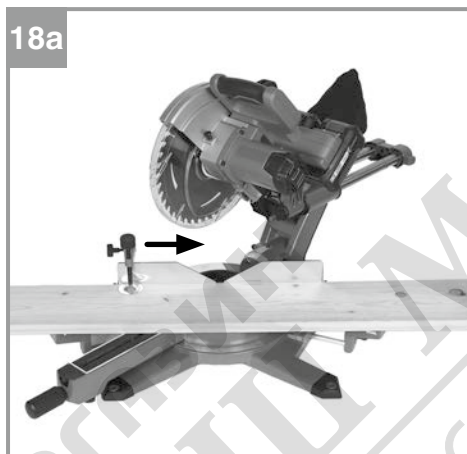
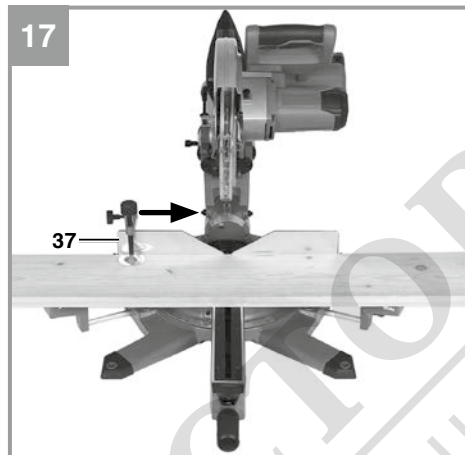

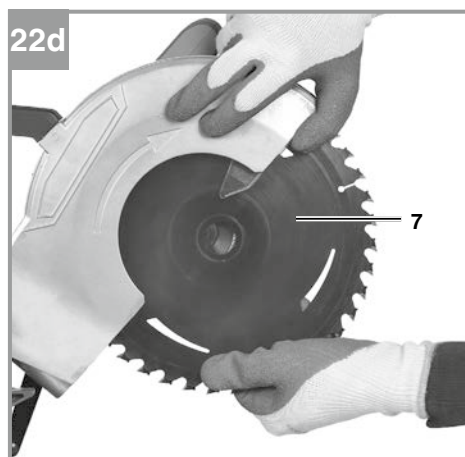
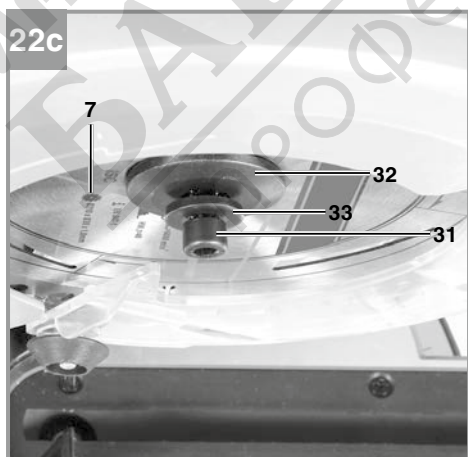
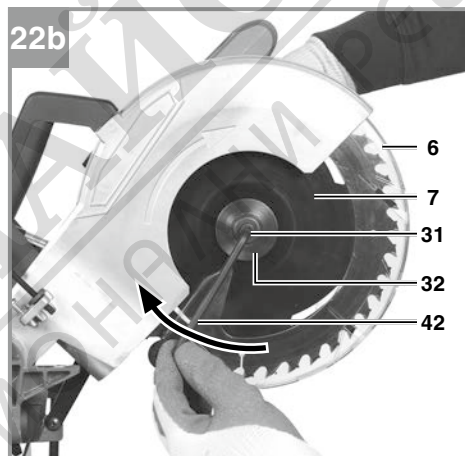
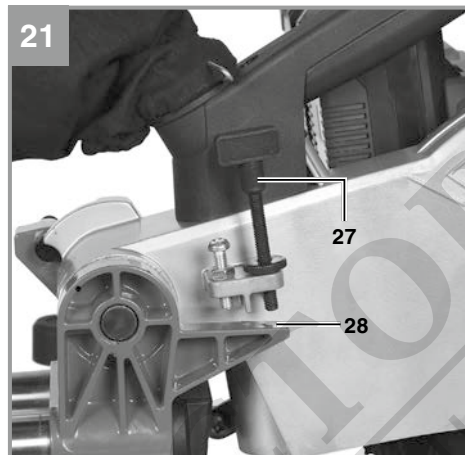
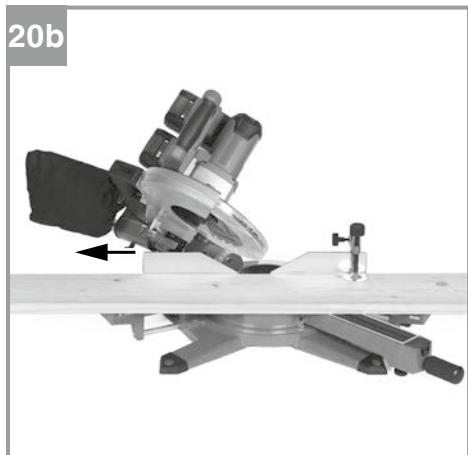

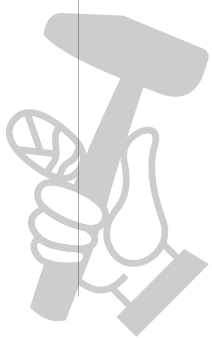
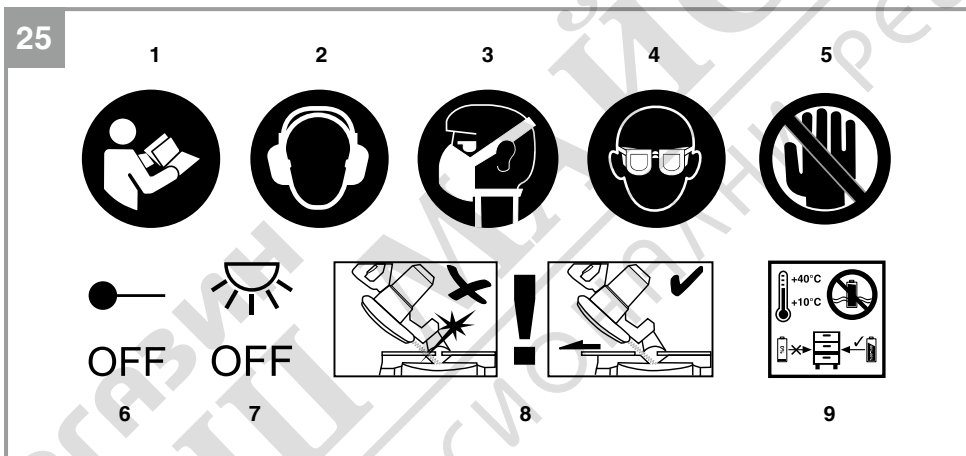
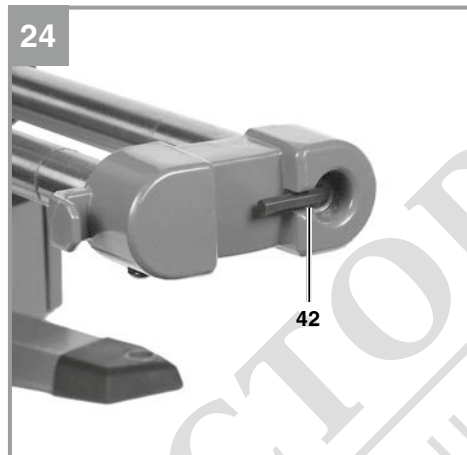
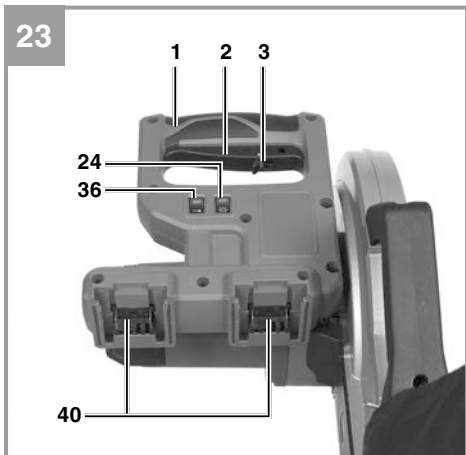

МАГАЗИН ФАКТОРА
 БАШНИКОВЫХ РЕШЕНИЙ
 ПРОФЕССИОНАЛЬНЫЕ РЕШЕНИЯ

Danger!

When using the equipment, a few safety precautions must be observed to avoid injuries and damage. Please read the complete operating instructions and safety regulations with due care. Keep this manual in a safe place, so that the information is available at all times. If you give the equipment to any other person, hand over these operating instructions and safety regulations as well. We cannot accept any liability for damage or accidents which arise due to a failure to follow these instructions and the safety instructions.

Explanation of the symbols used (see Fig. 25)

1. **Danger!** - Read the operating instructions to reduce the risk of injury
2. **Caution! Wear ear-muffs.** The impact of noise can cause damage to hearing.
3. **Caution! Wear a breathing mask.** Dust which is injurious to health can be generated when working on wood and other materials. Never use the device to work on any materials containing asbestos!
4. **Caution! Wear safety goggles.** Sparks generated during working or splinters, chips and dust emitted by the device can cause loss of sight.
5. **Caution! Risk of injury!** Do not reach into the running saw blade.
6. **On/Off switch for laser.**
7. **On/Off switch for LED lamp.**
8. **Warning!** To make miter cuts (with the saw head inclined or the turntable set at an angle), the adjustable stop rail must be fixed at an outer position. To make 90° crosscuts, the adjustable stop rail must be fixed at the inner position.
9. Store the batteries only in dry rooms with an ambient temperature of +10°C to +40°C. Place only fully charged batteries in storage (charged at least 40%). (Not supplied)

1. Safety regulations

The corresponding safety information can be found in the enclosed booklet.

Warning!

Read all the safety information, instructions, illustrations and technical data provided on or with this power tool. Failure to adhere to the following instructions may result in electric shock, fire and/or serious injury.

Keep all the safety information and instructions in a safe place for future use.

Special information about the laser

Caution: Laser radiation
Do not look into the beam
Laser class 2



- Never look directly into the laser path.
- Never direct the laser beam at reflecting surfaces or persons or animals. Even a low output laser beam can inflict injury on the eye.
- **Caution:** It is vital to follow the work procedures described in these instructions. Using the equipment in any other way may result in hazardous exposure to laser radiation.
- Never open the laser module.
- It is prohibited to carry out any modifications to the laser to increase its power.
- The manufacturer cannot accept any liability for damage due to non-observance of the safety information.
- Switch off the laser when not in use.

2. Layout and items supplied**2.1 Layout (Fig. 1-24)**

1. Handle
2. On/Off switch
3. Release lever
4. Machine head
5. Spindle lock
6. Adjustable blade guard
7. Blade
8. Clamping device
9. Transport handle
10. Locking screw for drag guide
11. Fixed stop rail
12. Adjustment screw for fixed stop rail
13. Adjustable foot
14. Locking screw for turntable
15. Pointer (turntable)
16. Scale (turntable)
17. Turntable

18. Fixed saw table
19. Scale (saw head)
20. Pointer (saw head)
21. Locking lever for machine head
22. Sawdust bag
23. LED lamp
24. On/Off switch for LED lamp
25. Retaining pin
26. Locking screw for clamping device
27. Screw with knurled nut for cutting depth limiter
28. Stop for cutting depth limiter
29. Adjustment screw - 0° setting
30. Adjustment screw - 45° setting
31. Flange bolt
32. Outer flange
33. Washer
34. Foot
35. Laser
36. On/Off switch for laser
37. Adjustable stop rail
38. Locking screw for adjustable stop rail
39. Battery pack (not supplied)
40. Mount for battery pack
41. Charger (not supplied)
42. Combination key
43. Cap for locking screw
44. Screw for locking screw
45. Shaft
46. Release button
- 47a. Adjustable workpiece support (left)
- 47b. Adjustable workpiece support (right)
48. Lever for workpiece support
49. Stop screw for workpiece support
50. Folding longitudinal stop
51. Dust extraction connector
52. Table insert
53. Screw for transport handle
54. Holder for clamping device (horizontal)

2.2 Items supplied

Please check that the article is complete as specified in the scope of delivery. If parts are missing, please contact our service center or the sales outlet where you made your purchase at the latest within 5 working days after purchasing the product and upon presentation of a valid bill of purchase. Also, refer to the warranty table in the service information at the end of the operating instructions.

- Open the packaging and take out the equipment with care.
- Remove the packaging material and any packaging and/or transportation braces (if available).

- Check to see if all items are supplied.
- Inspect the equipment and accessories for transport damage.
- If possible, please keep the packaging until the end of the guarantee period.

Danger!

The equipment and packaging material are not toys. Do not let children play with plastic bags, foils or small parts. There is a danger of swallowing or suffocating!

- Cordless crosscut saw
- Clamping device
- Transport handle
- Locking screw for turntable
- Sawdust bag
- Combination key
- Cap for locking screw
- Screw for locking screw
- Adjustable workpiece support (left and right)
- Stop screw for workpiece support (2x)
- Screw for transport handle (2x)
- Original operating instructions
- Safety information

3. Proper use

The cordless crosscut saw is designed for cross-cutting wood and wood-type materials which are appropriate for the machine's size. The saw is not designed for cutting firewood.

The equipment is to be used only for its prescribed purpose. Any other use is deemed to be a case of misuse. The user / operator and not the manufacturer will be liable for any damage or injuries of any kind caused as a result of this.

Please note that our equipment has not been designed for use in commercial, trade or industrial applications. Our warranty will be voided if the machine is used in commercial, trade or industrial businesses or for equivalent purposes.

The equipment is to be operated only with suitable saw blades. It is prohibited to use any type of cutting-off wheel.

To use the equipment properly you must also observe the safety information, the assembly instructions and the operating instructions to be found in this manual.

All persons who use and service the equipment have to be acquainted with these operating instructions and must be informed about the equipment's potential hazards. It is also imperative to observe the accident prevention regulations in force in your area. The same applies for the general rules of health and safety at work. The manufacturer will not be liable for any changes made to the equipment nor for any damage resulting from such changes. Even when the equipment is used as prescribed it is still impossible to eliminate certain residual risk factors. The following hazards may arise in connection with the machine's construction and design:

- Contact with the saw blade in the uncovered saw zone.
- Reaching into the running saw blade (cut injuries).
- Kick-back of workpieces and parts of workpieces.
- Saw blade fracturing.
- Catapulting of faulty carbide tips from the saw blade.
- Damage to hearing if essential ear-muffs are not used.
- Harmful emissions of wood dust when used in closed rooms.

4. Technical data

Motor power supply	36 V d.c.
Idle speed n_0	3800 rpm
Carbide saw blade	$\varnothing 254 \times \varnothing 30 \times 2.5$ mm
Number of teeth	40
Swiveling range	$-47^\circ / 0^\circ / +47^\circ$
Miter cut to the left	0° to 45°
Saw width at 90°	340×85 mm
Saw width at 45°	240×85 mm
Saw width at $2 \times 45^\circ$ (double miter cut, left)	240×47 mm
Max. cutting height	85 mm
Max. workpiece depth	340 mm
Weight	approx. 14.2 kg
Laser class	2
Wavelength of laser	650 nm
Laser output	≤ 1 mW
Protection class	III/◇

Minimum workpiece size: Only ever cut workpieces which are big enough to clamp securely with the clamping device – minimum length 180 mm.

This machine is intended for use with rechargeable batteries and chargers from the Einhell Power-X family only. For the current models, please refer to the product descriptions for the articles. These are available online.

Danger! Noise

The noise emission values were measured in accordance with EN 62841.

L_{pA} sound pressure level	86.1 dB(A)
K_{pA} uncertainty	3 dB(A)
L_{WA} sound power level	99.1 dB(A)
K_{WA} uncertainty	3 dB(A)

Wear ear-muffs.

The impact of noise can cause damage to hearing.

The stated noise emission values were measured in accordance with a set of standardized criteria and can be used to compare one power tool with another.

The stated noise emission values can also be used to make an initial assessment of exposure.

Warning:

The noise emission levels may vary from the level specified during actual use, depending on the way in which the power tool is used, especially the type of workpiece it is used for.

Keep the noise emissions and vibrations to a minimum.

- Only use appliances which are in perfect working order.
- Service and clean the appliance regularly.
- Adapt your working style to suit the appliance.
- Do not overload the appliance.
- Have the appliance serviced whenever necessary.
- Switch the appliance off when it is not in use.

Caution!

Residual risks

Even if you use this electric power tool in accordance with instructions, certain residual risks cannot be ruled out. The following hazards may arise in connection with the equipment's construction and layout:

1. Lung damage if no suitable protective dust mask is used.

2. Damage to hearing if no suitable ear protection is used.
3. Health damage caused by hand-arm vibrations if the equipment is used over a prolonged period or is not properly guided and maintained.

5. Before starting the equipment

Warning!

Always remove the battery pack before making adjustments to the equipment.

5.1 General information

- The equipment must be set up where it can stand securely, i.e. it should be bolted to a workbench, a universal base frame or similar.
- In the area of the machine's legs (34) there is a fastening hole in each leg. Use them for fastening standard screws, washers, spring washers and nuts (not included in the scope of this delivery - they are available from your dealer). Fasten the machine on all four legs.
- All covers and safety devices have to be properly fitted before the equipment is switched on.
- It must be possible for the blade to run freely.
- When working with wood that has been processed before, watch out for foreign bodies such as nails or screws, etc.
- Before you actuate the On/Off switch, make sure that the saw blade is correctly fitted and that the equipment's moving parts run smoothly.

5.2 Assembling the saw (Figs. 1-9, 24)

- Fasten the transport handle (9) to the machine head (4) using the screws (53).
- Insert the screw (44) in the hole in the locking screw (14) and position the combination key (42) on the head of the screw.
- Now fit the locking screw (14) to the shaft (45), so that the screw (44) goes into the threaded hole. Fasten the locking screw (14) to the shaft (45) by the screw (44).
- Plug the cap (43) onto the locking screw (14).
- Insert the guide pins of the adjustable workpiece supports (47) into the mounting holes on the machine housing.
- To move the workpiece supports (47) to the innermost position, actuate the lever (48) on the underside of the workpiece support.
- Tighten the stop screws (49) on the guide

rails in order to secure the workpiece supports against falling out.

- To fit the sawdust bag (22) to the dust extraction connector (51) on the crosscut saw, spread the metal ring apart on the opening. When the metal ring is back in its original shape, the sawdust bag is held securely in position.
- The clamping device (8) can be fitted on the left or right of the fixed saw table (18).
- Always fasten the clamping device (8) with the locking screw (26).
- For the horizontal clamping of workpieces you can anchor the clamping device in the holder (54).
- **Note:** The combination key (42) should be kept on the basket of the machine (see Fig. 24).

5.3 Adjusting the saw (Figs. 1-4, 9-10)

- To adjust the turntable (17), loosen the locking screw (14) by approx. 2 turns, which frees the turntable (17). Only then is it possible to adjust the turntable while holding the release button (46) pressed down.
- Turn the turntable (17) and scale pointer (15) to the desired angular setting on the scale (16).
- The saw has locking positions at angles of -45°, -30°, -22.5°, -15°, 0°, 15°, 22.5°, 30° and 45°, at which the turntable (17) audibly clicks into position. Once the turntable is engaged, the setting must be additionally secured by tightening the locking screw (14).
- If different angle settings are required, the turntable (17) may be secured in position using only the locking screw (14).
- To release the saw from its position at the bottom, pull the retaining pin (25) out of the motor mounting while pressing down lightly on the machine head (4).
- Swing up the machine head (4).
- To move out the workpiece supports (47) press the lever on the bottom side of the workpiece support (48) and then pull the workpiece support outwards to the right or left.
- For repeat cuts of identical length you can unfold the longitudinal stop (50).
- When the locking lever (21) is loosened, you can tilt the machine head (4) to the left by up to 45°. After the desired angular setting has been set on the scale pointer (20) on the scale (19), secure the machine head (4) again with the locking lever (21).
- To ensure that the saw is standing securely,

adjust the adjustable foot (13) by turning it so that the saw stands in a horizontal and firm position.

- The machine head (4) can be moved backwards and forwards using the drag function. To prevent the drag function, the guide rails can be fixed in a specific position with the locking screw (10).

5.4 Precision adjustment of the stop rail (Fig. 11)

- Lower the machine head (4) and fasten in place with the retaining pin (25).
- Fasten the turntable (17) in 0° position.
- Place the 90° stop angle (a) between the blade (7) and the stop rail (11).
- Slacken the four adjustment screws (12) using a hex key, set the stop rail (11) to 90° in relation to the saw blade (7) and retighten the adjustment screws (12).
- The angle stop (a) and hex key (4 mm) are not included in the scope of this delivery - they are available from your dealer.

5.5 Precision adjustment of the stop for crosscut 90° (Figs. 1, 12, 13)

- Fasten the turntable (17) in 0° position.
- Undo the locking lever (21) and move the machine head (4) all the way to the right using the handle (1).
- Place the 90° angular stop (a) between the blade (7) and the turntable (17).
- Adjust the adjustment screw (29) until the angle between the blade (7) and the turntable (17) equals 90°.
- Finally, check the position of the pointer (20) on the scale (19). If the pointer (20) still does not show the correct angle on the scale, it can be readjusted.
- To readjust it, undo the fastening screw on the pointer (20) using a screwdriver. Move the pointer to the desired scale position and then retighten the fastening screw.
- The angle stop (a) and hex key (4 mm) are not included in the scope of this delivery - they are available from your dealer.

5.6 Precision adjustment of the stop for miter cuts 45° (Figs. 1, 12, 14)

- Fasten the turntable (17) in 0° position.
- Undo the locking lever (21) and move the machine head (4) all the way to the left using the handle (1), until it coincides at 45°.
- Place the 45° stop angle (b) between the blade (7) and the turntable (17).

- Adjust the adjustment screw (30) so that the angle between the blade (7) and the turntable (17) equals exactly 45°.
- The angle stop (b) and hex key (4 mm) are not included in the scope of this delivery - they are available from your dealer.

6. Operation

6.1 Charging the lithium-ion battery pack (Figs. 15, 16, 23)

1. Remove the rechargeable battery (39) from the mount (40) by pressing the pushlock button on the battery and pulling it out of the mount.
2. Check that your mains voltage is the same as that marked on the rating plate of the battery charger. Insert the power plug of the charger (41) into the socket outlet. The green LED will then begin to flash.
3. Push the battery pack onto the battery charger.

In section (Charger indicator) you will find a table with an explanation of the LED indicator on the charger.

If the battery pack fails to charge, check for the following:

- voltage at the power socket
- whether there is good contact at the charging contacts of the charging unit

If the battery pack still fails to charge, send

- the charger and charging adapter
 - and the battery pack
- to our customer service center.

To ensure that items are properly packaged and delivered when you send them to us, please contact our customer service or the point of sale at which the equipment was purchased.

When shipping or disposing of batteries and cordless tools, always ensure that they are packed individually in plastic bags to prevent short circuits and fires.

To ensure that the battery pack provides long service, you should take care to recharge it promptly. You must recharge the battery pack when you notice that the performance of the device drops.

Never allow the battery pack to become fully discharged. This will cause it to develop a defect.

6.2 Battery capacity indicator (Fig. 16)

Press the button for the battery capacity indicator (c). The battery capacity indicator (d) shows the charge status of the battery using 3 LEDs.

All 3 LEDs are lit:

The battery is fully charged.

2 or 1 LED(s) are lit:

The battery has an adequate remaining charge.

1 LED flashes:

The battery is empty, recharge the battery.

All LEDs blink:

The battery temperature is too low. Remove the battery from the equipment, keep it at room temperature for one day. If the fault reoccurs, this means that the rechargeable battery has undergone exhaustive discharge and is defective. Remove the battery from the equipment. Never use or charge a defective battery.

6.3 Adjusting the movable stop rail (Figs. 17-20)

Warning! To make 90° crosscuts, the adjustable stop rail (37) must be fixed at the inner position:

- Undo the locking screw (38) of the adjustable stop rail and push the adjustable stop rail inwards.
- The adjustable stop rail (37) must be fixed far enough in front of the innermost position that the distance between the stop rail (37) and the saw blade (7) amounts to a maximum of 5mm.
- Before making a cut, check that the stop rail and the saw blade cannot collide.
- Tighten the locking screw (38) again.

Warning! To make 0°-45° miter cuts (with the saw head inclined or the turntable set at an angle), the adjustable stop rail (37) must be fixed at an outer position.

- Undo the locking screw (38) of the adjustable stop rail and push the adjustable stop rail outwards.
- The adjustable stop rail (37) must be fixed far enough in front of the innermost position that the distance between the stop rail (37) and

the saw blade (7) amounts to a maximum of 5mm.

- Before making a cut, check that the stop rail and the saw blade cannot collide.
- Tighten the locking screw (38) again.

Warning! The adjustable stop rail on the right-hand side must always remain fixed at the inner position.

6.4 Cross cut 90° and turntable 0° (Fig. 1-4, 9, 17)

For cutting widths up to approx. 100 mm it is possible to fix the saw's drag function with the locking screw for drag guide (10) in rear position. If the cutting width exceeds 100 mm you must ensure that the locking screw for drag guide (10) is slackened and that the machine head (4) can be moved.

- Move the machine head (4) to its upper position.
- Use the handle (1) to push back the machine head (4) and fix it in this position if required (dependent on the cutting width).
- Place the piece of wood to be cut at the stop rail (11) and on the turntable (17).
- Lock the material with the clamping device (8) on the fixed saw table (18) to prevent the material from moving during the cutting operation.
- Clamp flat material which has the wide side lying on the table using the clamping device aligned vertically (see Fig. 9a).
- Alternatively, clamp flat material which has the flat side on the table using the clamping device aligned horizontally (see Fig. 9b).
- Press the release lever (3) to release the On/Off switch (2).
- Press the On/Off switch (2) to start the motor.
- With the drag guide fixed in place: Use the handle (1) to move the machine head (4) steadily and with light pressure downwards until the saw blade (7) has completely cut through the workpiece.
- With the drag guide not fixed in place: Pull the machine head (4) all the way to the front and then use the handle (1) to move it downwards steadily and with light pressure. Now push the machine head (4) slowly and steadily to the very back until the saw blade (7) has completely cut through the workpiece.
- When the cutting operation is completed, move the machine head (4) back to its upper (home) position and release the On/Off button (2).

Important! The integral resetting springs will automatically lift the machine head. Do not simply let go of the handle (1) after cutting, but allow the machine head (4) to rise slowly, applying slight counter pressure as it does so.

6.5 Cross cut 90° and turntable 0° - 45° (Fig. 1-4, 18)

The crosscut saw can be used to make crosscuts of 0°- 45° to the left and 0° - 45° to the right in relation to the stop rail.

- Release the turntable (17) by undoing the locking screw (14).
- Turn the turntable (17) and scale pointer (15) to the desired angular setting on the scale (16).
- Retighten the locking screw (14) to secure the turntable (17) in place.
- Cut as described in section 6.4.

6.6 Miter cut 0°- 45° and turntable 0° (Fig. 1-4, 19)

The crosscut saw can be used to make miter cuts of 0- 45° in relation to the work face.

- If necessary, dismantle the clamping device (8) from the left side of the saw table (18) or mount on the right-hand side of the fixed saw table (18).
- Move the machine head (4) to its upper position.
- Fasten the turntable (17) in 0° position.
- Set the miter angle on the machine head as described in 5.5.
- Cut as described in section 6.4.

6.7 Miter cut 0°- 45° and turntable 0°- 45° (Fig. 1-4, 20)

The crosscut saw can be used to make miter cuts to the left of 0°-45° in relation to the work surface, with simultaneous setting of the turntable from 0°-45° to the left or 0°-45° to the right in relation to the stop rail (double miter cut).

- If required, dismantle the clamping device (8) or mount on the opposite side of the fixed saw table (18).
- Move the machine head (4) to its upper position.
- Release the turntable (17) by undoing the locking screw (14).
- Use the handle (1) to adjust the turntable (17) to the angle required (in this connection see also section 6.5).
- Retighten the locking screw (14) to secure the turntable in place.
- Adjust the miter angle on the machine head

and the stop rail as described under points 5.5 and 6.3.

- Cut as described in section 6.4.

6.8 Limiting the cutting depth (Fig. 21)

- The cutting depth can be infinitely adjusted using the screw (27). To do so, undo the knurled nut on the screw (27). Turn the screw (27) in or out to set the required cutting depth and then retighten the knurled nut on the screw (27).
- Check the setting by completing a test cut.

6.9 Sawdust bag (Fig. 8)

The saw is equipped with a sawdust bag (22). The sawdust bag (22) can be emptied by means of a zipper at the bottom.

6.10 Replacing the saw blade (Fig. 1, 22)

- **Danger!** Remove the rechargeable battery before you replace the blade.
- Wear work gloves to prevent injury when changing the saw blade.
- Press the spindle locking system (5) with one hand while positioning the combination key (42) on the flange bolt (31) with the other hand. The spindle locking system (5) engages after no more than one rotation.
- Now, using a little more force, slacken the flange bolt (31) in the clockwise direction.
- Turn the flange bolt (31) right out and remove the washer (33) and the outer flange (32).
- Take the blade (7) off the inner flange and pull out downwards.
- Carefully clean the flange bolt (31), washer (32), outer flange (33) and inner flange.
- Fit and fasten the new saw blade (7) in reverse order.
- **Important!** The cutting angle of the teeth, in other words the direction of rotation of the saw blade (7) must coincide with the direction of the arrow on the housing.
- Check to make sure that all safety devices are properly mounted and in good working condition before you begin working with the saw again.
- **Warning!** Every time that you change the saw blade, check that the saw blade guard (6) opens and closes again in accordance with requirements. Also check that the saw blade (7) spins freely in the saw blade guard (6).
- **Warning!** Every time that you change the saw blade, check to see that it spins freely in the table insert (52) in both perpendicular and

- 45° angle settings.
- **Warning!** You should replace the table insert (52) immediately whenever it is worn or damaged. To do so, undo the recessed head screws in the table insert (52) and take the table insert out of the turntable (17). To fit the new table insert (52), proceed in reverse order.
- **Warning!** The work to change and align the saw blade (7) must be carried out correctly.

6.11 Transport (Figs. 1-4)

- Retighten the locking screw (14) to secure the turntable (17) in place.
- Press the machine head (4) downwards and secure with the retaining pin (25). The saw is now locked in its bottom position.
- Carry the machine by the transport handle (9).
- To set up the equipment again, proceed as described in section 5.2 + 5.3.

6.12 Operating the laser (Figs. 12, 23)

Switching on: Move the On/Off switch (36) to the “●—” position to switch on the laser (35). A laser line is projected onto the material you wish to process, providing an exact guide for the cut.

Switching off: Move the On/Off switch (36) to the “OFF” position.

6.13 Operating the LED lamp (Figs. 12, 23)

- For good illumination of the work area you can use the LED lamp in addition to the room lighting. The On/Off switch (24) for the LED lamp is on the top of the machine head, between the handle (1) and the mount for the rechargeable battery (40).
- Switching on: Switch position “”
- Switching off: Switch position “OFF”

7. Cleaning, maintenance and ordering of spare parts

Danger!

Always pull out the battery pack before starting any cleaning work.

7.1 Cleaning

- Keep all safety devices, air vents and the motor housing free of dirt and dust as far as possible. Wipe the equipment with a clean cloth or blow it with compressed air at low pressure.

- We recommend that you clean the device immediately each time you have finished using it.
- Clean the equipment regularly with a moist cloth and some soft soap. Do not use cleaning agents or solvents; these could attack the plastic parts of the equipment. Ensure that no water can seep into the device. The ingress of water into an electric tool increases the risk of an electric shock.

7.2 Carbon brushes

In case of excessive sparking, have the carbon brushes checked only by a qualified electrician.

Danger! The carbon brushes should not be replaced by anyone but a qualified electrician.

7.3 Maintenance

There are no parts inside the equipment which require additional maintenance.

7.4 Ordering replacement parts:

Please quote the following data when ordering replacement parts:

- Type of machine
- Article number of the machine
- Identification number of the machine
- Replacement part number of the part required

For our latest prices and information please go to www.Einhell.Service.com

8. Disposal and recycling

The equipment is supplied in packaging to prevent it from being damaged in transit. The raw materials in this packaging can be reused or recycled. The equipment and its accessories are made of various types of material, such as metal and plastic. Never place defective equipment in your household refuse. The equipment should be taken to a suitable collection center for proper disposal. If you do not know the whereabouts of such a collection point, you should ask in your local council offices.

9. Storage

Store the equipment and accessories in a dark and dry place at above freezing temperature. The ideal storage temperature is between 5 and 30 °C. Store the electric tool in its original packaging.

10. Charger indicator

Indicator status		Explanations and actions
Red LED	Green LED	
Off	Flashing	<p>Ready for use The charger is connected to the mains and is ready for use; there is no battery pack in the charger</p>
On	Off	<p>Charging The charger is charging the battery pack in quick charge mode. The charging times are shown directly on the charger. Important! The actual charging times may vary slightly from the stated charging times depending on the existing battery charge.</p>
Off	On	<p>The battery is charged and ready for use. (READY TO GO) The unit then changes over to gentle charging mode until the battery is fully charged. To do this, leave the rechargeable battery on the charger for approx. 15 minutes longer. Action: Take the battery pack out of the charger. Disconnect the charger from the mains supply.</p>
Flashing	Off	<p>Adapted charging The charger is in gentle charging mode. For safety reasons the charging is performed less quickly and takes more time. The reasons can be: - The rechargeable battery has not been used for a very long time. - The battery temperature is outside the ideal range. Action: Wait for the charging to be completed; you can still continue to charge the battery pack.</p>
Flashing	Flashing	<p>Fault Charging is no longer possible. The battery pack is defective. Action: Never charge a defective battery pack. Take the battery pack out of the charger.</p>
On	On	<p>Temperature fault The battery pack is too hot (e.g. due to direct sunshine) or too cold (below 0° C). Action: Remove the battery pack and keep it at room temperature (approx. 20° C) for one day .</p>



For EU countries only

Never place any electric power tools in your household refuse.

To comply with European Directive 2012/19/EC concerning old electric and electronic equipment and its implementation in national laws, old electric power tools have to be separated from other waste and disposed of in an environment-friendly fashion, e.g. by taking to a recycling depot.

Recycling alternative to the return request:

As an alternative to returning the equipment to the manufacturer, the owner of the electrical equipment must make sure that the equipment is properly disposed of if he no longer wants to keep the equipment. The old equipment can be returned to a suitable collection point that will dispose of the equipment in accordance with the national recycling and waste disposal regulations. This does not apply to any accessories or aids without electrical components supplied with the old equipment.

Please note that batteries and lamps (e.g. light bulbs) must be removed from the tool before it is disposed of.

The reprinting or reproduction by any other means, in whole or in part, of documentation and papers accompanying products is permitted only with the express consent of the Einhell Germany AG.

Subject to technical changes



Service information

We have competent service partners in all countries named on the guarantee certificate whose contact details can also be found on the guarantee certificate. These partners will help you with all service requests such as repairs, spare and wearing part orders or the purchase of consumables.

Please note that the following parts of this product are subject to normal or natural wear and that the following parts are therefore also required for use as consumables.

Category	Example
Wear parts*	Carbon brushes, Battery
Consumables*	Saw blade
Missing parts	

* Not necessarily included in the scope of delivery!

In the effect of defects or faults, please register the problem on the internet at www.Einhell-Service.com. Please ensure that you provide a precise description of the problem and answer the following questions in all cases:

- Did the equipment work at all or was it defective from the beginning?
- Did you notice anything (symptom or defect) prior to the failure?
- What malfunction does the equipment have in your opinion (main symptom)? Describe this malfunction.

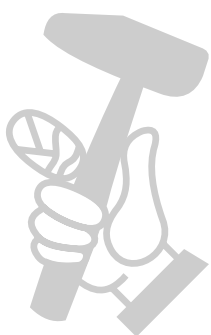

Warranty certificate

Dear Customer,

All of our products undergo strict quality checks to ensure that they reach you in perfect condition. In the unlikely event that this equipment develops a fault, please contact our service department at the address shown on this guarantee card. You can also contact us by telephone using the service number shown. Please note the following terms under which guarantee claims can be made:

1. These guarantee terms apply solely to consumers, i.e. natural persons, who do not want to use this product in connection with either their commercial or other self-employed activities. These guarantee terms regulate additional guarantee services which the undermentioned manufacturer promises to buyers of its new products in addition to their statutory rights of guarantee. Your statutory rights of guarantee are not affected by this guarantee. Our guarantee is free of charge to you.
2. The guarantee services cover only defects due to material or manufacturing faults on the new product which you have bought in the European Union from the undermentioned manufacturer and are limited to either the rectification of said defects or the replacement of the product, whichever we prefer. Please note that only equipment under the brand name "Professional" has been designed for use in commercial, trade or professional applications. For all other products the guarantee is invalidated if the equipment is used within the guarantee period in commercial, trade or industrial applications or for other equivalent activities.
3. Our guarantee does not cover:
 - Damage to the equipment caused by failure to comply with the installation/assembly instructions or by unprofessional installation; damage caused by failure to comply with the operating instructions (e.g. connection to the wrong mains voltage or current type); damage caused by failure to comply with the maintenance and safety regulations; damage caused by exposing the equipment to abnormal environmental conditions; damage resulting from poor care and maintenance.
 - Damage to the equipment caused by misuse or incorrect applications (e.g. overloading the equipment or using non-approved attachments or accessories); damage caused by foreign bodies (e.g. sand, stones, dust, ...) getting inside the equipment. Damage in transit; damage caused by force or external influences (e.g. by dropping the equipment).
 - Damage to the equipment or parts of the equipment which is owed to use-related, normal or otherwise natural wear. For example, batteries and battery packs are manufactured with a cycle limit for design-related reasons. Wear is negatively influenced in particular by load demands and charging speeds as well as exposure to heat, cold, vibration and impact.
4. The guarantee is valid for a period of 2 years starting from the purchase date of the equipment. Guarantee claims must be submitted before the end of the guarantee period and within two weeks of the defect being noticed. No guarantee claims will be accepted after the end of the guarantee period. The original guarantee period remains applicable to the equipment even if repairs are carried out or parts are replaced. In such cases, the work performed or parts fitted will not result in an extension of the guarantee period, and no new guarantee will become active for the work performed or for any replacement parts fitted. This also applies if on-site service is used.
5. To assert your guarantee claim, register the defective equipment at: www.Einhell-Service.com. You will need to provide proof of purchase of the new item of equipment. Equipment returned without such proof or without a rating plate are excluded from the guarantee services because of the lack of traceability. If the defect is covered by our guarantee, then either the item in question will be repaired immediately and returned to you or we will send you a new replacement.
6. If you have taken the equipment with you to a different EU country than where you bought it, we will arrange for a local service partner to provide the guarantee services. If you take the equipment outside the EU, the guarantee will not apply.

Of course, we are also happy to offer a chargeable repair service for any defects which are not covered or no longer covered by the scope of this guarantee. To take advantage of this service, please send the equipment to our service address. We draw attention to the restrictions of this guarantee concerning wear parts, consumables and missing parts as presented in the service information included in this operating manual.

Warrantor/ Service:

Einhell UK Ltd, Unit 10, 1st Floor, Champion's Business Park, Arrowse Brook Road, Upton, Wirral, CH49 0UQ