

ROTHENBERGER

SUPERTRONIC 3-4 SE

SUPERTRONIC 3-4 SE



DE Bedienungsanleitung
EN Instructions for use
FR Instruction d'utilisation
ES Instrucciones de uso
IT Istruzioni d'uso
NL Gebruiksaanwijzing
PT Instruções de serviço
DA Brugsanvisning
SV Bruksanvisning

NO Bruksanvisning
FI Käyttöohje
PL Instrukcja obsługi
CS Návod k používání
TR Kullanım kılavuzu
HU Kezelési útmutató
HR Upute za uporabu
EL Οδηγίες χρήσεως
RU Инструкция по использованию



rothenberger.com

A Overview

no. 56250 SUPERTRONIC 3 SE, Standard die head, BSPT R1/2 - 3", 230V
no. 56253 SUPERTRONIC 3 SE, Standard die head, BSPT R1/2 - 3", 110V
no. 56255 SUPERTRONIC 3 SE, Automatic die head, BSPT R1/2 - 3", 230V
no. 56465 SUPERTRONIC 4 SE, Automatic die head, BSPT R1/2 - 4", 230V
no. 56475 SUPERTRONIC 4 SE, Automatic die head, BSPT R1/2 - 4", 110V
no. 56466 SUPERTRONIC 4 SE, Automatic die head, NPT 1/2 - 4", 230V

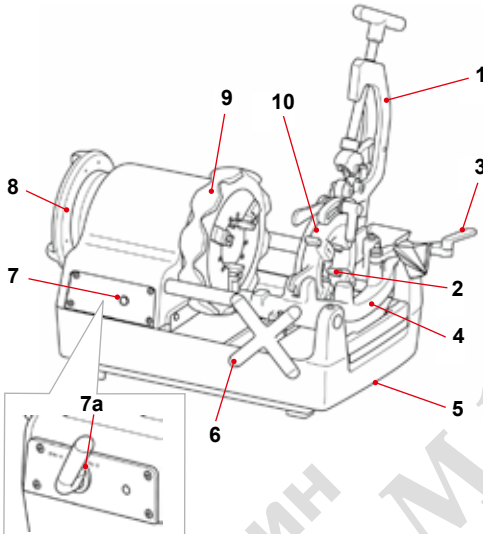

SUPERTRONIC 3SE:

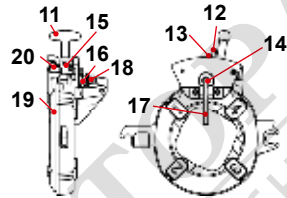

SUPERTRONIC 4SE:

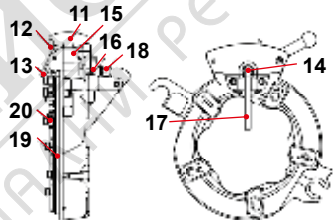

B Clamping

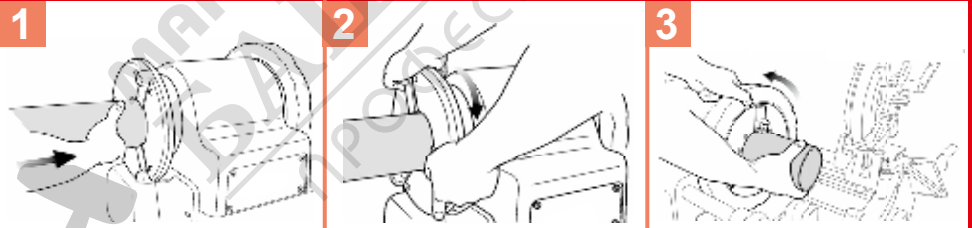

C Cutting

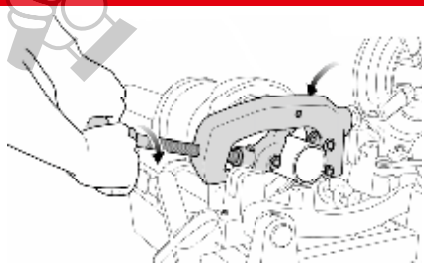

D Reaming

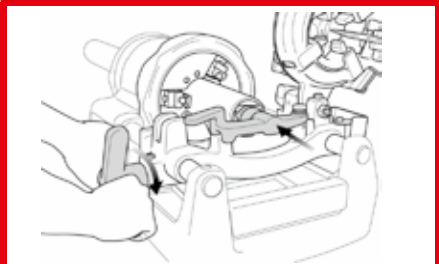

Remove and installing thread jaws

E

AUTOMATIC - DIE HEAD



STANDARD - DIE HEAD

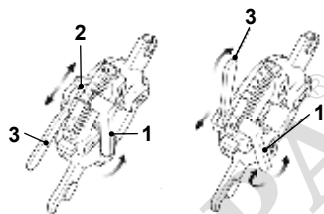

Changing thread size

F

AUTOMATIC - DIE HEAD

1/2" - 2"

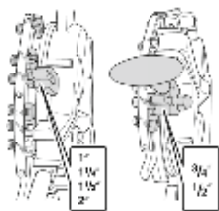

2 1/2" - 4"

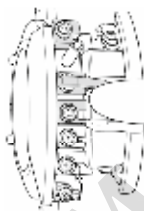

STANDARD - DIE HEAD

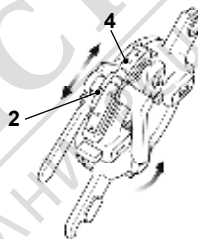

Threading

G

AUTOMATIC - DIE HEAD

„B“

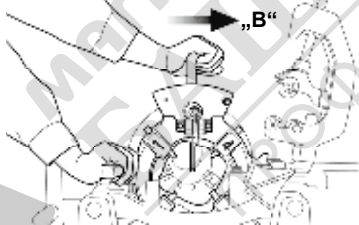

STANDARD - DIE HEAD

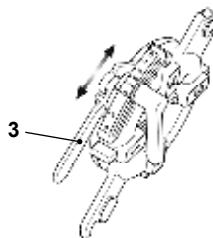

Changing clamping jaws

H

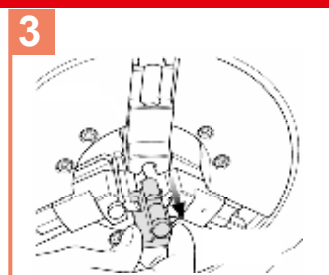
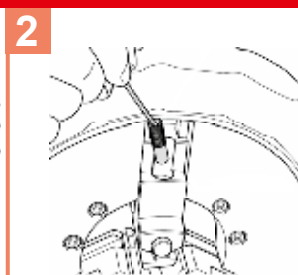
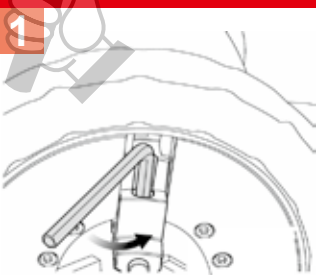

Intro

EU-KONFORMITÄTSEKTLÄRUNG

Wir erklären in alleiniger Verantwortung, dass dieses Produkt mit den angegebenen Normen und Richtlinien übereinstimmt.

EU-DECLARATION OF CONFORMITY

We declare on our sole accountability that this product conforms to the standards and guidelines stated.

DECLARATION EU DE CONFORMITÉ

Nous déclarons sous notre propre responsabilité que ce produit est conforme aux normes et directives indiquées.

DECLARACION DE CONFORMIDAD EU

Declaramos, bajo nuestra responsabilidad exclusiva, que este producto cumple con las normas y directivas mencionadas.

DICHARAZIONE DI CONFORMITÀ EU

Dichiariamo su nostra unica responsabilità, che questo prodotto è conforme alle norme ed alle direttive indicate.

EU-KONFORMITEITSEKTLÄRUNG

Wij verklaren in eigen verantwoordelijkheid dat dit product overeenstemt met de van toepassing zijnde normen en richtlijnen.

DECLARAÇÃO DE CONFORMIDADE EU

Declaramos, sob responsabilidade exclusiva, que o presente produto está conforme com as Normas e Directivas indicadas.

EU-KONFORMITETSEKTLÄRUNG

Vi erklærer som eneansvarlig, at dette produkt er i overensstemmelse med anførte standarder, retningslinjer og direktiver.

EU-FÖRSÄKRAN

Vi försäkrar på eget ansvar att denna produkt uppfyller de angivna normerna och riktlinjerna.

EU-SAMSVARSEKTLÄRUNG

Vi erklærer på eget ansvar at dette produktet stemmer overens med de følgende normer eller normative dokumenter.

TODISTUS EU-STANDARDINMUKAISUUDESTA

Todistamme täten ja vastaamme yksin siitä, että tämä tuote on allalueteltujen standardien ja standardomisasiakirjojen vaatimusten mukainen.

DEKLARACJA ZGODNOŚCI EU

Oświadczamy z pełną odpowiedzialnością, że produkt ten odpowiada wymaganiom następujących norm i dokumentów normatywnych.

EU-PROHLÁŠENÍ O SHODI

Se vši zodpovědností prohlašujeme, že tento výrobek odpovídá následujícím normám a normativním dokumentům.

EU UYGUNLUK BEYANI

Tek sorumlu olarak bu ürünün yönetmelik hükümleri uyarınca araştırarak normlara ve norm dokümanlarına uygunluğunu beyan ederiz.

EU-AZONOSSÁGI NYILATKOZAT

Teljes felelősségünk tudatában kijelentjük, hogy jelen termék megfelel a következő szabványoknak vagy szabványossági dokumentumoknak.

EU-IZJAVA O USKLAĐENOSTI

Izjavljujemo s punom odgovornošću da je ovaj proizvod u skladu s navedenim standardima i smjernicama.

ΔΗΛΩΣΗ ΣΥΜΜΟΡΦΩΣΗΣ ΕΕ

Δηλώνουμε με αποκλειστική μας ευθύνη, ότι αυτό το προϊόν ανταποκρίνεται στα ακόλουθα πρότυπα ή έγγραφα τυποποίησης.

ДЕКЛАРАЦИЯ О СООТВЕТСТВИИ СТАНДАРТАМ ЕВ

Мы заявляем что этот продукт соответствует следующим стандартам.



SUPERTRONIC 3SE, SUPERTRONIC 4 SE:

2014/30/EU, 2006/42/EC, 2011/65/EU, EN 61029-1,
EN 61029-2-12, EN 55014-1, EN IEC 61000-3-2
EN 61000-3-3

Herstellerunterschrift

Manufacturer/ authorized representative signature

Thomas Bamberger
Managing Director

i. V. Maximilian Gottschalk
Head of Innovation
Management

Kelkheim, 11.10.2022

Technische Unterlagen bei/ Technical file at:
ROTHENBERGER Werkzeuge GmbH
Spessartstraße 2-4
D-65779 Kelkheim/Germany

Intro

DEUTSCH - Originalbetriebsanleitung! Bedienungsanleitung bitte lesen und aufbewahren! Nicht wegwerfen! Bei Schäden durch Bedienungsfehler erlischt die Garantie! Technische Änderungen vorbehalten!	Seite 2
ENGLISH Please read and retain these directions for use. Do not throw them away! The warranty does not cover damage caused by incorrect use of the equipment! Subject to technical modifications!	Page 17
FRANÇAIS Lire attentivement le mode d'emploi et le ranger à un endroit sûr! Ne pas le jeter! La garantie est annulée lors de dommages dus à une manipulation erronée! Sous réserve de modifications techniques!	Page 31
ESPAÑOL ¡Por favor, lea y conserve el manual de instrucciones! ¡No lo tire! ¡En caso de daños por errores de manejo, la garantía queda sin validez! Modificaciones técnicas reservadas!	Página 46
ITALIANO Per favore leggere e conservare le istruzioni per l'uso! Non gettarle via! In caso di danni dovuti ad errori nell'uso, la garanzia si estingue! Ci si riservano modifiche tecniche!	Pagina 61
NEDERLANDS Lees de handleiding zorgvuldig door en bewaar haar goed! Niet weggooien! Bij schade door bedieningsfouten komt de garantieverlening te vervallen! Technische wijzigingen voorbehouden!	Bladzijde 76
PORTUGUES Queiram ler e guardar o manual de instruções! Não deitar fora! Em caso de avarias por utilização incorrecta, extingue-se a garantia! Reservado o direito de alterações técnicas!	Página 90
DANSK Læs betjeningsvejledningen, og gem den til senere brug! Smid den ikke ud! Skader, som måtte opstå som følge af betjeningsfejl, medfører, at garantien mister sin gyldighed! Ret til tekniske ændringer forbeholdes!	Side 104
SVENSKA Läs igenom bruksanvisningen och förvara den väl! Kasta inte bort den! Garantin upphör om apparaten har använts eller betjänats på ett felaktigt sätt! Med reservation för tekniska ändringar!	Sida 117
NORSK Les bruksanvisningen og oppbevar den vell! Ikke kast den! Oppstår skader på grunn av betjeningsfeil opphører garantiens gyldighet! Tekniske forandringer forbeholdes!	Side 131
SUOMI Lue ja säilytä tämä käyttöohje! Älä heitä pois! Takuu ei kata käyttövirheistä aiheutuvia vahinkoja! Oikeudet teknisiin muutoksiin pidätetään!	Sivulta 145
POLSKI Instrukcję obsługi proszę przeczytać i zachować! Nie wyrzucać! Przy uszkodzeniach wynikających z błędów obsługi wygasa gwarancja! Zmiany techniczne zastrzeżone!	Strony 159
ČESKY Navod k obsluze si prosím přečtěte a uschovejte jej! Nevyhazujte jej! V případě poškození způsobenem chybnou obsluhou zanika záruka! Technické změny jsou vyhrazeny!	Stránky 17
TÜRKÇE Kullanım açıklmalarını lütfen dikkatlice okuyunuz ve bir yerde muhafaza ediniz! Çöpe atmayınız! Kullanımında yapılan hatalar, garantinin silinmesine neden olur! Teknik deðişiklikler yapma hakkımız saklıdır!	Sayfa 188
MAGYAR Kérjük, olvassa el és őrizze meg a kezelési utasítást! Ne dobja el! A helytelen kezelésből származó károsodások esetén megszűnik a jótállás! Műszaki változtatások fenntartva!	Oldaltól 202
HRVATSKI Molimo da pročitate i spremite upute za uporabu! Nemojte ih baciti! Kod kvarova zbog pogrešne uporabe odbacuje se jamstvo! Zadržavamo pravo tehničkih izmjena!	Stranica 216
ΕΛΛΗΝΙΚΑ Οδηγίες χειρισμού παρακαλείσθε να τις διαβάσετε και να τις φυλάσσετε! Μην τις πετάξετε! Σε ζημιές από σφάλματα χειρισμού παύει να ισχύει η εγγύηση! Με επιφύλαξη για τεχνικές αλλαγές!	Σελίδα 230
РУССКИЙ Прочтите инструкцию по эксплуатации и сохраняйте её для дальнейшего использования! В случае поломки инструмента из-за несоблюдения инструкции клиент теряет право на обслуживание по гарантии! Возможны технические изменения!	Страница 246

1	Safety Notes	18
1.1	Intended use.....	18
1.2	General safety instructions	18
1.3	Special safety instructions	19
2	Technical Data	21
3	Function of the Unit	21
3.1	Overview (A).....	21
3.2	Functional description.....	22
4	Preparations for operation	22
4.1	Transporting the threading machine	22
4.2	Setting up the machine	22
4.3	Electrical connection.....	22
4.4	The thread cutting oil.....	23
4.5	Checking the thread cutting oil.....	23
4.6	Setting the supplied thread cutting oil quantity	23
4.7	Draining off the oil.....	24
5	Operation of the threading machine	24
5.1	Clamping the workpieces (B).....	24
5.2	Cutting the workpiece with the pipe cutter (C).....	24
5.3	Reaming the workpieces (D).....	25
5.4	Removing and installing the dies (E).....	25
5.4.1	Automatic thread-tapping head.....	25
5.4.2	Standard thread-tapping head.....	25
5.5	Installing and removing the thread-tapping head into and out of the bed carriage	26
5.6	Changing the thread size (F)	26
5.7	Tapping threads (G)	26
5.8	Setting the thread length (only Automatic thread-tapping head).....	27
5.9	Setting the thread depth (only automatic thread-tapping head)	27
5.10	Removing the workpiece	27
5.11	Cleaning after use	28
6	Maintenance and inspection	28
6.1	Changing the internal deburrer blade.....	28
6.2	Changing the pipe cutter cutting wheel	28
6.3	Changing the clamping jaw inserts (H).....	29
6.4	Daily inspection	29
6.5	Lubrication of spindle support.....	29
7	Accessories.....	29
8	Customer service.....	29
9	Disposal.....	30
9.1	Metal, electrical and electronic parts.....	30
9.2	Oils and lubricants.....	30

Markings in this document:



Markings in this document!

This sign warns against the danger of personal injuries.



Caution!

This sign warns against the danger of property damage and damage to the environment.



Call for action



1 Safety Notes

1.1 Intended use

The thread-tapping machine SUPERTRONIC 3 SE and 4 SE may only be used for cutting off and deburring and making bolt threads as described in Chapter 2 "Technical data".

The SUPERTRONIC thread-tapping machines may only be operated with suitable standard and automatic tapping heads that have been inspected and recommended by ROTHENBERGER, and with thread-tapping jaws as described in Chapter 2 "Technical data".

The supplied safety pedal carries the GS approval of the professional liability insurers' association and is compulsory for using the machine in the Federal Republic of Germany.

Never make technical or design modifications to the thread-tapping machine and to the accessory parts.

→ This would render the operating permit void and would represent an accident and injury risk.

When using electrical tools and machines, basic safety measures must be observed and followed in order to provide protection against electric shock, injury and fire risks. Read the instructions precisely before using the machine.

Always keep the safety instructions to hand.

1.2 General safety instructions



ATTENTION! When using electric tools, the following fundamental safety measures must be taken to prevent electric shock, injury or fire.

Read all of these instructions before you use the electric tool, and store the safety instructions properly.

Service and maintenance:

- 1 **Regular cleaning, maintenance and lubrication.** Always unplug electrical plug before any adjustment, maintenance or repair.
- 2 **Have your device repaired only by qualified experts and only with original replacement parts.** This ensures the continued safety of the device.

Working safely:

- 1 **Keep your work area orderly.** A messy work area can cause accidents.
- 2 **Consider environmental influences.** Do not expose electric tools to rain. Do not use electric tools in damp or wet environments. Keep the work area well lit. Do not use electric tools where there is a risk of fire or explosion.
- 3 **Protect yourself from electric shock.** Avoid physical contact with earthed parts (such as pipes, radiators, electric stoves or cooling devices).
- 4 **Keep other people away.** Do not let other people — especially children — touch the electric tool or its cable. Keep them away from the work area.
- 5 **Store electric tools safely when they are not in use.** Unused electric tools should be kept in a dry, high or closed area, out of reach of children.
- 6 **Do not overload your electric tool.** Work is better and safer within the performance range indicated.

- 7 **Use the right electric tool.** Don't use low-performance machines for heavy-duty jobs. Do not use the electric tool for purposes for which it was not intended. For example, do not use a portable circular saw for cutting tree branches or logs.
- 8 **Wear proper clothing.** Do not wear loose clothing or jewellery, as they can get caught in moving parts. When working outdoors, wear slip-resistant shoes. Wear a hairnet over long hair.
- 9 **Use protective gear.** Wear safety glasses. Wear a breathing mask during work that creates dust.
- 10 **Connect the dust extraction equipment.** If there are connections to dust extraction and collection equipment, make sure that they are connected and properly used.
- 11 **Do not use the cable for purposes for which it was not intended.** Never use the cable to pull the plug from the socket. Protect the cable from heat, oil and sharp edges.
- 12 **Secure the work piece.** Use clamps or a vice to hold the work piece firmly. They will hold it more securely than your hand can.
- 13 **Avoid abnormal postures.** Make sure to stand securely and always keep your balance.
- 14 **Maintain your tools with care.** For better and safer work, keep cutting tools sharp and clean. Follow the instructions for lubrication and changing tools. Regularly inspect the electric tool's connection cable, and if it is damaged, have it replaced by an authorized expert. Regularly check extension cords and replace them if they are damaged. Keep the handles dry, clean and free of oil and grease.
- 15 **Pull the plug from the socket.** When not using the electric tool, before maintenance or when changing tools, such as saw blades, drills and cutting bits.
- 16 **Do not leave any tool keys inserted.** Before switching on, check to see that keys and adjustment tools have been removed.
- 17 **Avoid unintentional activation.** When plugging the tool in, make sure that the switch is turned off.
- 18 **Use outdoor extension cords.** When outdoors, use only extension cords that are approved and appropriately marked.
- 19 **Be alert.** Pay attention to what you do. Approach your work sensibly. Do not use the electric tool when you are distracted.
- 20 **Check the electric tool for damage.** Before using the electric tool, you must inspect safety equipment or slightly damaged parts carefully to ensure that they work properly and as intended. Check to see that the moving parts operate freely and don't stick, and to make sure no parts are damaged. All parts must be mounted properly and meet all the conditions for ensuring trouble-free operation of the electric tool.
Damaged safety equipment and parts must be properly repaired or replaced by a professional facility, unless otherwise indicated in the user manual. Damaged switches must be replaced by a customer service facility.
Never use an electric tool whose switch cannot be turned on and off.
- 21 **Caution.** Using other insertion tools and accessories may cause injury.
- 22 **Have your tool repaired by an electrical expert.** This electric tool meets applicable safety requirements. Repairs must be made only by an electrical expert using original replacement parts. Otherwise accidents may occur.

1.3 Special safety instructions

Keep floor dry and free of slippery materials such as oil. Slippery floors invite accidents.

Restrict access or barricade the area when work piece extends beyond machine to provide a minimum of one metre clearance from the work piece. Restricting access or barricading the work area around the work piece will reduce the risk of entanglement.

Keep all electrical connections dry and away from the floor. Do not touch plugs or the machine with wet hands. These safety precautions reduce the risk of electric shock.

Keep hands away from rotating pipes or fittings. Switch off the machine before cleaning pipe threads or screwing on fittings. Let the machine come to a complete standstill be-

fore touching the pipe. This procedure reduces the possibility of getting trapped by rotating parts.

In order to avoid safety hazards, if the power supply cord needs to be replaced, this must be done by ROTHENBERGER or by an after-sales service centre that is authorised to repair ROTHENBERGER power tools.

Never put fingers, your face, hair or other parts of the body, or loose, wide items of clothing into the operating and intake areas of rotating parts (workpiece, clamping chuck, centring chuck). Do not wear jewellery (rings, chains etc.). Risk of injury and accidents!

In the event of faults (unusual smell, vibrations, unusual noises) during work with the SUPERTRONIC 3/4SE, it is essential to immediately press the safety pedal and perform an EMERGENCY STOP of the machine!

If the machine is running, it is prohibited to hold the workpieces manually or to perform similar work, and to fit and remove parts such as filters, valves, pipe sections etc!

Wear safety clothing! Wear a safety mask to provide protection against splashes of thread cutting oil as well as any chlorine gas vapours (from thread cutting oil burning on hot tool and workpiece surfaces)! Wear a safety hat to cover and protect long hair. Wear safety gloves when changing the dies, the pipe cutting wheel and the pipe deburrer. Wear safety gloves when changing the tool and workpiece. The thread and dies get hot during thread cutting! Wear safety footwear. Risk of injury (slipping) on any escaping thread cutting oil! Risk of injury from wet, slippery and possibly off-centre machine parts when changing the tool!

Do not remove metal chips using compressed air! There is a risk of eye injuries and loss of eyesight!

Ensure sufficient ventilation during indoor use (closed rooms). The permissible ambient temperature is between 0°C and 40°C!

Before changing the die head, the cutting wheel, the pipe deburrer, always switch off the machine and pull out the mains plug (de-energized operation)!!

After it has been switched off, the machine still coasts for a while until it comes to a standstill.

Do not touch any parts before the machine is completely stationary and the mains plug has been pulled out!

In the case of the threaded pipes, carry out a pressure test in order to ensure that no gas or water can escape after the pipes are fitted!

Power tool plugs must match the outlet. Never modify the plug in any way. Do not use any adapter plugs with earthed (grounded) power tools. Unmodified plugs and matching outlets will reduce risk of electric shock

Use the power tool, accessories and tool bits etc., in accordance with these instructions, taking into account the working conditions and the work to be performed. Use of the power tool for operations different from those intended could result in a hazardous situation.

Follow instructions on proper use of this machine. Do not use for other purposes such as drilling holes or turning winches.

Secure machine to bench or stand. Support long heavy pipe with pipe supports.

While operating the machine, stand on the side where the REVERSE/OFF/FORWARD or FORWARD/REVERSE switch is located.

Keep covers in place. Do not operate the machine with covers removed.

Do not use this machine if the footswitch is broken or missing

Setting-up or fixing power tool in a stable position as appropriate for power tools which can be mounted on a support or fixed to the floor.

Keep handles and grasping surfaces dry, clean and free from oil and grease. Slippery handles and grasping surfaces do not allow for safe handling and control of the tool in unexpected situations.

SUPERTRONIC 3 SE SUPERTRONIC 4 SE

Cutting capacity BSPT R/ NPT	1/4" - 3"	1/4" - 4"
Bolt thread	3/8" - 2"	3/8" - 2"
Cutting material	Steel, Stainless Steel...	Steel, Stainless Steel
Speed under no load	33 min ⁻¹ (rpm)	22/50 min ⁻¹ (rpm)
Single-phase universal motor.....	1700 W	1750 W
Frequency	50/60 Hz	50/60 Hz
Dimensions (LxWxH, mm)	650x480x420	750x540x480
Weight (without accessories)	74 kg	105 kg
Thread-tapping head (standard).....	1/2" - 2", 2" - 3"	
Thread-tapping head (automatic)	1/2" - 2", 2.1/2" - 3"	1/2" - 2", 2.1/2" - 4"
Thread jaws	1/2" - 3/4", 1" - 2" 2.1/2" - 3"	1/2" - 3/4", 1" - 2", 2.1/2" - 4"
Noise pressure level (L _{pA} K _{pA})	85 3 dB (A)	85 3 dB (A)
Sound power level (L _{WA} K _{WA}).....	96 3 dB (A)	96 3 dB (A)
The noise level during operation can exceed 85 dB (A). Wear hearing protection!		
Measured values determined in accordance with EN 61029-1.		
Vibration total value (m/s ²)	< 2,5 K= 1,5	< 2,5 K= 1,5

The vibration level given in this information sheet has been measured in accordance with a standardized test given in EN 61029 and may be used to compare one tool with another. It may be used for a preliminary assessment of exposure.



The declared vibration emission level represents the main applications of the tool. However if the tool is used for different applications, with different accessories or insertion tools or is poorly maintained, the vibration emission may differ. This may significantly increase the exposure level over the total working period.

An estimation of the level of exposure to vibration should also take into account the times when the tool is switched off or when it is running but not actually doing the job. This may significantly reduce the exposure level over the total working period.

Identify additional safety measures to protect the operator from the effects of vibration such as: maintain the tool and the accessories, keep the hands warm, organization of work patterns.

3 Function of the Unit

3.1 Overview

(A)

- | | | | |
|-----------|----------------------------|-----------|------------------------------|
| 1 | Pipe cutter | 11 | T-handle |
| 2 | Thread-tapping jaws | 12 | Selector pin (silver) |
| 3 | Internal deburrer | 13 | Selector pin (black) |
| 4 | Tool carriage | 14 | Thread length adjustment |
| 5 | Oil drainage screw | 15 | Profile body |
| 6 | Feeder hand wheel | 16 | Profile pin |
| 7 | Overload protection switch | 17 | Locking lever, body |
| 7a | Shift Lever (only 4SE) | 18 | Locking lever, clamping head |
| 8 | Centring chuck | 19 | Cam plate |
| 9 | Clamping chuck | 20 | Selector block |
| 10 | Thread-tapping head | | |



3.2 Functional description

Threads are cut or turned on workpieces such as pipes or rods in the thread-tapping machine SUPERTRONIC 3 SE and 4 SE.

The machine consists of:

- a drive motor that rotates the centring chuck
- a clamping chuck for securing the workpiece
- a pipe cutter for cutting the workpiece to length
- an internal deburrer
- a thread-tapping head for making a thread on the workpiece
- an oil pump that lubricates and cools with thread-tapping oil
- a tool carriage guided on both sides with a toothed feed
- a chip collecting and oil trough
- a safety pedal
- a coasting restrictor

4 Preparations for operation

4.1 Transporting the threading machine



Bend at the knees when lifting the machine so as to protect your back against over-stressing.

Weighing more than 35 kg, you need 2 people to carry the machine safe!



Fix the tool carriage so that it cannot move while the machine is being transported. Hold the machine securely by its base to lift it. Do not hold the machine by its centring chuck or the internal deburrer when carrying it!



If the machine is transported with the thread-tapping oil still inside, the oil might splash out onto clothing due to vibrations!



Thread-tapping oil on the surface of the machine makes it slippery. Ensure that it does not slip out of your hands when you lift it!

4.2 Setting up the machine



Set up the machine in a dry location!

Place the machine on a level surface without spaces or on a flatwork bench. The centring chuck must be higher in relation to other parts of the machine so that no thread-tapping oil can escape via the pipe being machined and contaminate the floor!

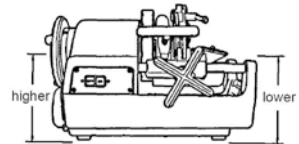

If you do not have a clear view of the dangerous area formed by the machine and the revolving workpiece, the full length of the revolving workpieces must be reduced or the dangerous area must be safeguarded by a cordon or warning signs! The safety fixtures must be set up and secured firmly. If supports are used for this purpose, they must be height-adjustable and sturdy and there must be a sufficient number of them!

4.3 Electrical connection



Do not place either the machine or workpieces on the connecting cable, otherwise the cable could be damaged and electrical current could be exposed, presenting an electric shock hazard!



Never touch the mains plug and mains cable with wet hands. Electric shock hazard!



When connecting the machine to the electricity supply, always ensure that the switch is set to "OFF", otherwise there is a risk that the machine will start up unnoticed and unsupervised when the power is connected!

- ! It is essential that the voltage on the machine's rating plate corresponds to the power source, otherwise the machine could get hot, smoke could develop, start a fire and cause damage!
- ! The integrated overload protection automatically stops the machine in the event of an overload or power fluctuations! Switching back on is not possible until one minute has elapsed!
- ! Use the extension cable H07 RN 3 x 1.5 mm²! The cable should not be longer than 30m!

4.4 The thread cutting oil

- ! For tapping, use ROTHENBERGER high-performance thread-tapping oil art. no. 65010. **This oil is not suitable for tapping drinking water pipes!**

Alternatively, you can use ROTHENBERGER high-performance thread-tapping fluid, art. no. 65015. This fluid **is suitable** for tapping all pipelines **including drinking water pipelines**.



Keep thread-tapping oils out of the reach of children!



Do not thin thread-tapping oil or mix it with other oils! If the thread-tapping oil becomes mixed with water, it turns milky-white, its quality is reduced and the tapped thread displays lower quality. It is then recommended to change the oil!

Avoid direct sunlight and store the oil in a dark place!

Close the oil container tight after use in order to prevent the ingress of dirt and water!



ATTENTION PERSONS WITH ALLERGIES!

Thread-tapping oil that lands on the skin can cause skin irritation, inflammation and allergic reactions! When handling oil, wear protective clothing and cover exposed skin areas. If your skin comes into contact with oil, wash it immediately with tap water and soap. If thread-tapping oil burns onto hot workpiece or tool surfaces, this can produce toxic vapours or gases (e.g. chlorine gas when red oil burns). If you have accidentally inhaled this oil mist or oil vapours, go out into the fresh air immediately and consult a doctor without delay!

4.5 Checking the thread cutting oil



When cleaning, servicing, inspecting or repairing the machine, it is essential to switch it off and pull out the mains plug (de-energised operation)!

- ➔ Turn the rotary handle clockwise in order to move the tool carriage to the clamping chuck.
- ➔ On the right side of the machine, fill up with the thread tapping oil to the level of the sieve mesh.
- ➔ Ensure that the machine is still switched off and insert the mains plug back into the socket.
- ➔ Switch on the machine and ensure that the thread-tapping oil runs out of the thread-tapping head to the cutting jaws. If the right amount of oil is not supplied, regulate it with the oil adjustment screw.

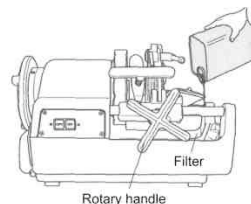

4.6 Setting the supplied thread cutting oil quantity



When cleaning, servicing, inspecting or repairing the machine, it is essential to switch it off and pull out the mains plug (de-energised operation)!

- ➔ Ensure that the oil tank is filled with oil up to the level of the sieve mesh.
- ➔ If the amount of thread-tapping oil running via the thread tapping head does not meet the requirements, the supplied amount must be adjusted with the aid of the oil adjustment screw.
- ➔ Undo the locking nut of the oil adjustment screw.
- ➔ Turning the oil adjustment screw clockwise increases the amount of oil delivered and turning it anti-clockwise reduces the amount.
- ➔ Tighten the locking nut firmly after making the adjustment.

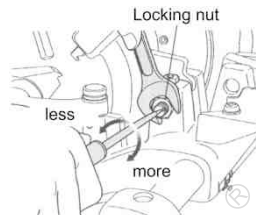

4.7 Draining off the oil



It is essential to also observe the safety and disposal regulations in Chapter 9!

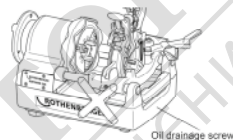

5 Operation of the threading machine

5.1 Clamping the workpieces

(B)



The tool carriage can make contact with the frame before the tapping process has ended and the clamping chuck and the machine can be damaged as a result! A clearance of at least 70 mm must therefore be maintained between the thread cut on the workpiece and the clamping chuck!

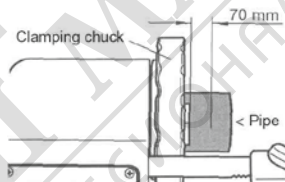

- ➔ Move the pipe cutter and the thread-tapping head up so that they are not in the way and position the internal deburrer on the rear side.
- ➔ Insert the workpiece from the centring chuck side (fig. 1) and tighten the centring chuck (fig. 2).
- ➔ Hold the workpiece on the clamping chuck side securely with your right hand and gradually tighten it with the clamping chuck (fig. 3).
- ➔ Ensure that the three clamping jaws are in contact with the workpiece.



If the three clamping jaws are not in contact with the workpiece, it will wobble and neither cutting nor thread cutting can be performed correctly!

- ➔ Clamp the workpiece securely and tighten it very firmly.

In the case of long or heavy pipes, it is essential to use the pipe support Art. No. 56047 in order to prevent the workpiece wobbling or twisting while it is being turned and to prevent the machine from tipping over due to the weight of the workpiece! Otherwise, the workpiece and the machine can become unstable!

5.2 Cutting the workpiece with the pipe cutter

(C)



Do not touch the cutting surface with bare hands, because it is hot and has sharp edges! Risk of injury and burning!

! If the handle of the pipe cutter is turned with force, the cutting surface of the pipe takes an oval shape, which makes correct thread-tapping impossible. Therefore, move the handle of the pipe cutter half a turn per whole pipe rotation!

- Move the pipe cutter up so that it is not in the way. Turn the feeder hand wheel in order to bring the pipe cutter into the position necessary for cutting the workpiece.
- Move the pipe cutter down onto the workpiece and then press the ON switch or press the pedal.
- Turn the handle of the pipe cutter powerfully clockwise and start to cut the workpiece. Ⓢ
- Swivel the pipe cutter down and back again.

! Do not collect the cut pipes in the trough! Take them out of the trough immediately after the cutting process ends!

5.3 Reaming the workpieces

(D)



The cutting tip of the internal deburrer is very sharp! Do not touch it with bare hands! Risk of cutting and injury!

- Pull the internal deburrer towards you.
- Turn the feeder hand wheel clockwise and gently press the cutting edge of the reamer against the inside of the pipe in order to ream.
- Turn the rotary handle further and gently press the cutting edge of the reamer against the inside of the pipe in order to ream.

5.4 Removing and installing the dies

(E)



Wear gloves in order to prevent cut injuries to the hands caused by the dies!

5.4.1 Automatic thread-tapping head

Removal:

- Pull the parking lever into the "A" position.
- Open the selector pin (silver colour) at the selector block.
- Lift out the thread-tapping head and pull the thread jaws no. 1 to 4 down (4SE: no. 1 to 5)

Installation:

- Pull the parking lever in the "A" direction.
- Open the selector pin (silver colour) at the selector block.
- Insert the thread jaws with the same number as on the respective thread-tapping head and make sure it engages audibly.
- Slide cam plate toward C until a click sound is heard from locking lever.
- Ensure that the numbers on the thread-tapping head and on the thread jaws are on the same side.

! Precise thread-tapping is only possible if the number on the slot of the thread-tapping head corresponds with the number on the thread jaw!

! After changing the thread-tapping jaws, check that they are secure! After changing the thread-tapping head or replacing the thread-tapping jaws, check that they are locked securely in the tool carriage!

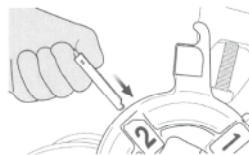

5.4.2 Standard thread-tapping head

Removal:

- Release the die holder (1), bring the cradle (2) into the lowest position, tighten the die and move the opening and closing lever (3) up to remove the thread jaws.
- Lift out the thread-tapping head and pull the thread jaws no. 1 to 4 down (4SE: no. 1 to 5).

Installation:

- Release the die holder (1), bring the cradle (2) into the lowest position, tighten the die and move the opening and closing lever (3) up to remove the thread jaws.
- Insert the thread jaws with the same number as on the respective thread-tapping head and make sure it engages audibly.
- Ensure that the numbers on the thread-tapping head and on the thread jaws are on the same side.
- Tighten the die and move the opening and closing lever (3) to remove the thread jaws.



Precise thread-tapping is only possible if the number on the slot of the thread-tapping head corresponds with the number on the thread jaw!

5.5 Installing and removing the thread-tapping head into and out of the bed carriage

- Lift the thread-tapping head to half height.
- Bring the thread-tapping head into the diagonal position and remove it.
- Not until the thread-tapping head is in a parallel position to the flat side of the thread-tapping pin can it be removed from or installed in the machine.

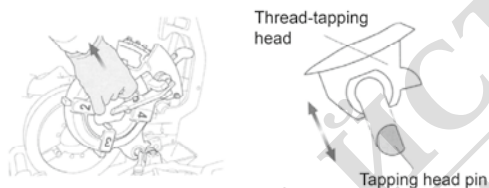

5.6 Changing the thread size

(F)

Automatic thread-tapping head:

- Ensure that the thread-tapping head is on the tool carriage and that the thread jaws correspond to the thread size.
- Insert the selector pin into the selector block with the necessary thread size.
- The size is shown on the respective selector block.

For the standard thread-tapping head:

- Balance the reading-off device on the cradlev (2) with the defined measuring division on the scale plate (4).

5.7 Tapping threads

(G)

- If there is a dangerous situation, press the safety pedal right down. This stops the machine.
- To restart the machine, press the release button on the side of the safety pedal.

To guarantee precisely ground threads, follow the instructions below:

Use only raw material that is in perfect condition for tapping threads. If you use deformed and / or pipes cut off at an angle, it is not possible to tap threads that conform to the relevant standards!

Use the thread-tapping head and the corresponding thread-tapping jaws that match the thread size!

Secure the thread-tapping head correctly on the tool carriage.

Do not place the thread-tapping head directly and unprotected on the floor and handle it with care!

Ensure that the thread-tapping oil runs on the thread-tapping jaws!

For the automatic thread-tapping head:

- Lower the thread-tapping head and insert the T handle, pressing in fully in the "B" direction until the thread-tapping jaws engage in the working position.
- Switch on the machine with the pedal; turn the rotary handle clockwise so that the thread jaws press onto the workpiece.

- Release the rotary handle when 2 to 3 thread turns are cut.
- The thread-tapping jaws open automatically via a longitudinal stop lever when the thread has been fully cut.
- Switch off the machine by taking your foot off the safety pedal.

Thread-tapping in 2 work steps (only 2½"…4"):

- To tap a thread on a pipe with a large diameter with low tension, first use the 2-step thread-tapping pin (black) for thread-tapping (pre-tapping) and then the selector pin (silver) for tapping (post-tapping) standard threads.

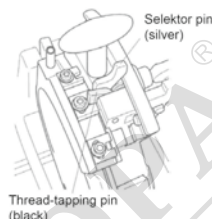

For the standard thread-tapping head:

- Lower the thread-tapping head and move the opening and closing lever (3) down towards you.
- Switch on the machine with the pedal, turn the rotary handle clockwise so that the thread jaws press on the workpiece.
- Release the rotary handle when two to three threads have been cut.
- With the machine running, slowly move the opening and closing lever (3) up when the required thread length has been cut, so as to end the cutting process by slowly opening the thread jaws.



If the thread jaws are opened jerkily, steps can be created in the last section of the thread, with the result that the thread is faulty!

5.8 Setting the thread length (only Automatic thread-tapping head)

The thread length was set by the manufacturer but can be changed if required.

- Pull the Locking Lever toward A to open Die-Head.
- Loosen Lock Nut and turn Adjust Screw clockwise depending on the required thread length.
- Right turning makes the thread length longer and left turning makes it shorter. The thread length will be adjusted about 2.5mm by one rotation.
- After adjustment, tighten Lock Nut.

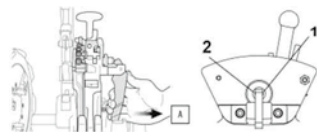

5.9 Setting the thread depth (only automatic thread-tapping head)

- Loosen the Block Screw securing the Selector Block to the Cam Plate.
- Move the Selector Block to adjust the thread depth. Sliding toward G makes deeper threads and H makes shallower threads. The thread depth will change by 1.5 to 2 threads under or over by one scale.
- Tighten the Block Screw to secure Selector Block and start threading.

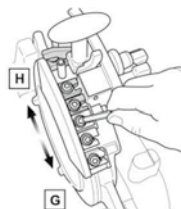

With the aid of a measuring instrument, check the cut pipe for a tapered thread etc. and correct the setting if necessary.

5.10 Removing the workpiece



The workpiece is damp and slippery from the thread-tapping oil. Carefully ensure that it does not slip out of your hands and drop onto your feet when you remove it from the machine!

- Turn the feeder hand wheel anti clockwise and move back the tool carriage.

- Release the clamping chuck.
- Release the centring chuck and pull out the workpiece.

5.11 Cleaning after use



Do not remove metal and plastic chips using compressed air! There is a risk of eye injuries and loss of eyesight! Do not pick up sharp-edged metal chips with your bare hands! Risk of injury! Wear protective gloves!

- Remove chips from on and around the machine.
- Use a wire brush to remove chips from and clean the clamping chuck, the thread-tapping jaws of the thread-tapping head and the internal deburrer.
- Use a cloth to wipe thread-tapping oil splashes from the machine and the workplace.

6 Maintenance and inspection

The plug or electrical cord should be replaced only by the manufacturer of the electric tool or by its repair service.

All machines are subject to natural wear during use. They must be maintained from time to time and wear parts must be replaced. This work may only be carried out by an authorized ROTHENBERGER service station. This gives you a full warranty on the material and workmanship!



If the machine is being cleaned, maintained, inspected or repaired, it is essential to switch it off and to pull out the mains plug (de-energized operation)! Always avoid uncontrolled starting-up of the machine. Risk of injury and accidents!

6.1 Changing the internal deburrer blade



Always wear protective gloves when replacing the blades! Risk of cuts and injury!

- Remove the spring pin out of the next of the reamer blade.
- The reamer blade is released when you pull the reamer blade holder forwards.
- Fit a new reamer blade.
- Put the previously removed spring pin back into the hole of the new reamer blade.

6.2 Changing the pipe cutter cutting wheel



Always wear protective gloves when replacing the blades! Risk of cuts and injury!

- Bring the pipe cutter into an upright position and lower the thread-tapping head.
- Pull off the cotter pin upwards.
- Hold the cutting wheel and push the cutting wheel straight pin slowly out on the opposite side.

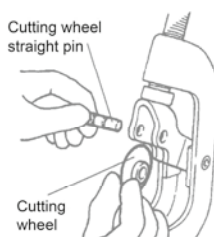
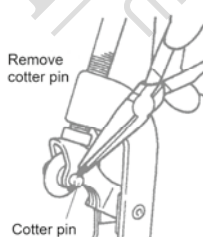

- Insert a new cutting wheel into the blade holder and insert the pin again.
- Insert a new cotter pin into the cutting wheel straight pin and secure it by bending it apart.

6.3 Changing the clamping jaw inserts

(H)

- Turn the clamping chuck and open it until an Allan key fits inside.
- Undo the screws that secure the clamping jaw inserts (fig. 1).
- Place a thin rod onto the upper edge of the spring and pull out the clamping chuck pin (fig. 2).
- Pull the clamping jaw insert forward (fig. 3).
- Insert a new clamping jaw insert and push it right to the back, replace the spring and the clamping chuck pin. Tighten the screw.

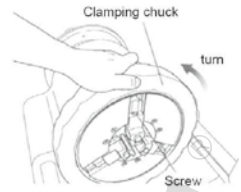

6.4 Daily inspection



Attention! Before starting the lubrication-works the power plug has to be taken out of the power source!

- Check the mains plug, mains cable and extension cable to ensure they are undamaged.
- Correctly filled oil trough.
- Clean the oil tank if there are impurities in it.
- Inspect the dies, pipe cutter and internal deburrer for any wear and replace parts if there is wear.
- Clean the clamping jaws with a wire brush if they are dirty.
- Check that the dowel screws are secure. Tighten if necessary.
- Remove dirt and chips from the machine regularly.
- Apply anti-rust grease if the machine is not going to be used for an extended period.
- The rear spindle support has to be lubricated periodically. The lubrication is only allowed for persons which have been supervised in electrical safety issues.

6.5 Lubrication of spindle support



The rear spindle support has to be lubricated periodically!

1. Unscrew the motor cover mounting bolts and remove the motor cover from the machine.
2. The grease nipple located behind of the scroll (Fig. 52).
3. Use grease gun to pour grease (Fig. 53).

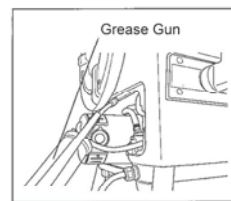
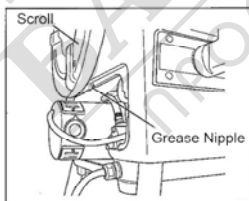

7 Accessories

You can find suitable accessories in the main catalog or at www.rothenberger.com

8 Customer service

The ROTHENBERGER service locations are available to help you (see listing in catalog or online) and replacement parts and service are also available through these same service locations. Order your accessories and spare parts from your specialist retailer or using RO SERVICE+ online: ☎ +49 (0) 61 95/ 800 8200 📠 +49 (0) 61 95/ 800 7491 ✉ service@rothenberger.com - www.rothenberger.com

9.1 Metal, electrical and electronic parts

Components of the unit are recyclable material and should be put to recycling. For this purpose registered and certified recycling companies are available. For an environmental friendly disposal of the non-recyclable parts (e.g. electronic waste) please contact your local waste disposal authority.

For EU countries only:



Do not dispose of electric tools with domestic waste. In accordance with European Directive 2012/19/EC on waste electrical and electronic equipment and its implementation as national law, electric tools that are no longer serviceable must be collected separately and utilised for environmentally compatible recycling.

9.2 Oils and lubricants

Only specialist companies are authorised to dispose of old oils.

Old oils and contaminated oils must be stored and disposed of in sealed, oil-resistant containers (metal drums).

Defective electrical appliances and machines that cannot be repaired must be opened and cleaned to remove the remaining oil.

Oil troughs must be cleaned so that there are no traces of oil. No oils (even very small amounts) may be allowed to enter the ground!



МАГАЗИН
БАШ МАЙСТОР
ПРОФЕСИОНАЛНИ РЕШЕНИЯ