

metabo®

FMV 18 LTX BL 8

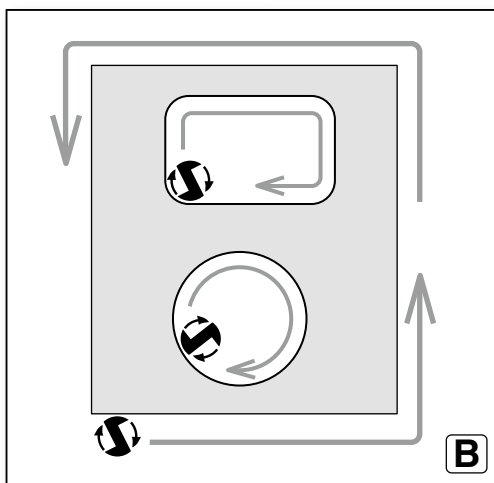

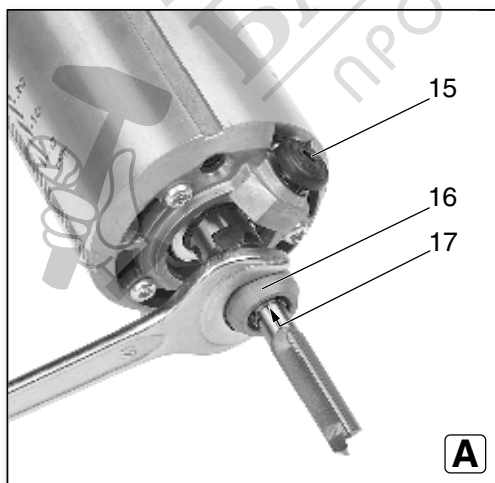
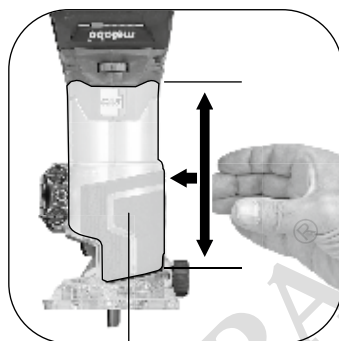
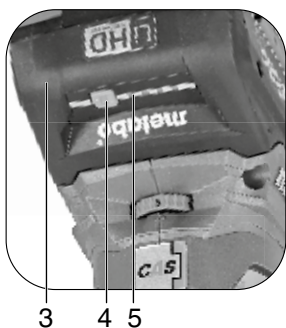

de	Originalbetriebsanleitung 6	fi	Alkuperäiset ohjeet 45
en	Original instructions 11	no	Original bruksanvisning 49
fr	Notice originale 16	da	Original brugsanvisning 53
nl	Oorspronkelijke gebruiksaanwijzing 21	pl	Instrukcja oryginalna 58
it	Istruzioni originali 26	el	Πρωτότυπο οδηγιών χρήσης 63
es	Manual original 31	hu	Eredeti használati utasítás 68
pt	Manual original 36	uk	Оригінальна інструкція з експлуатації 73
sv	Bruksanvisning i original 41		

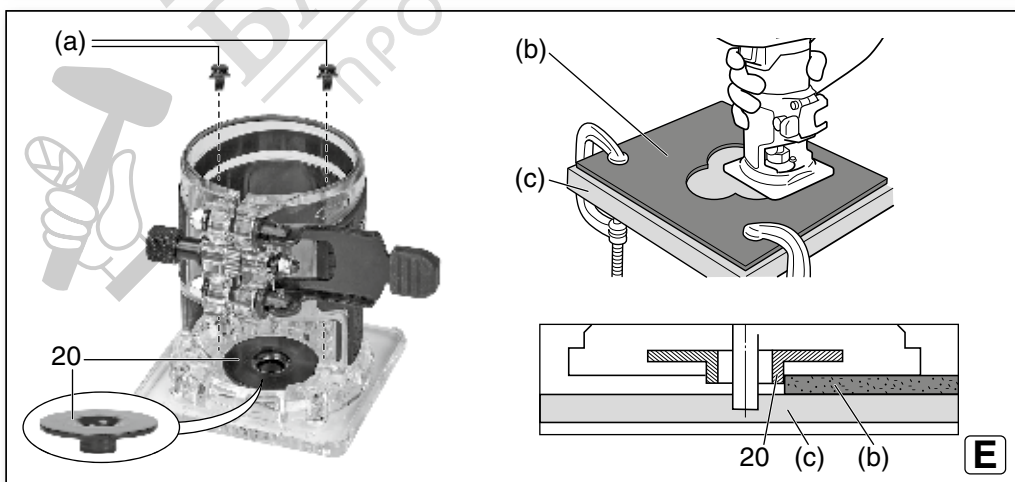
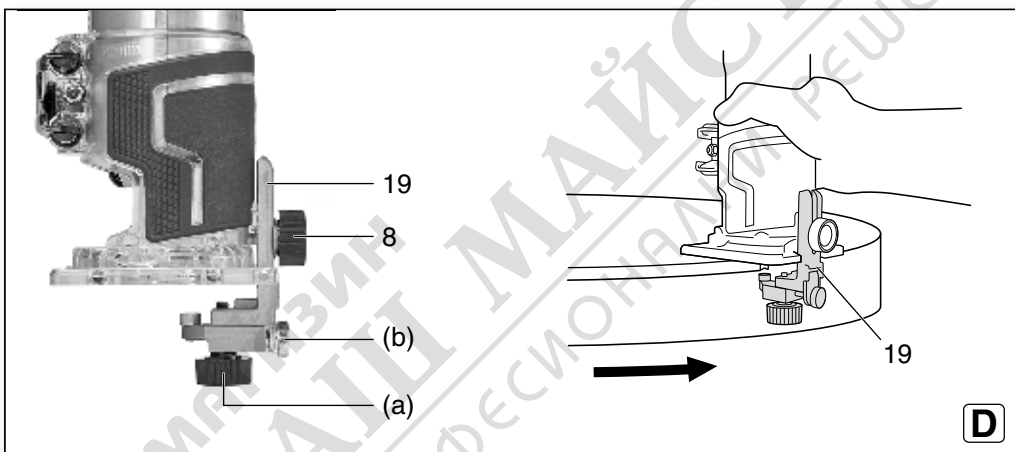
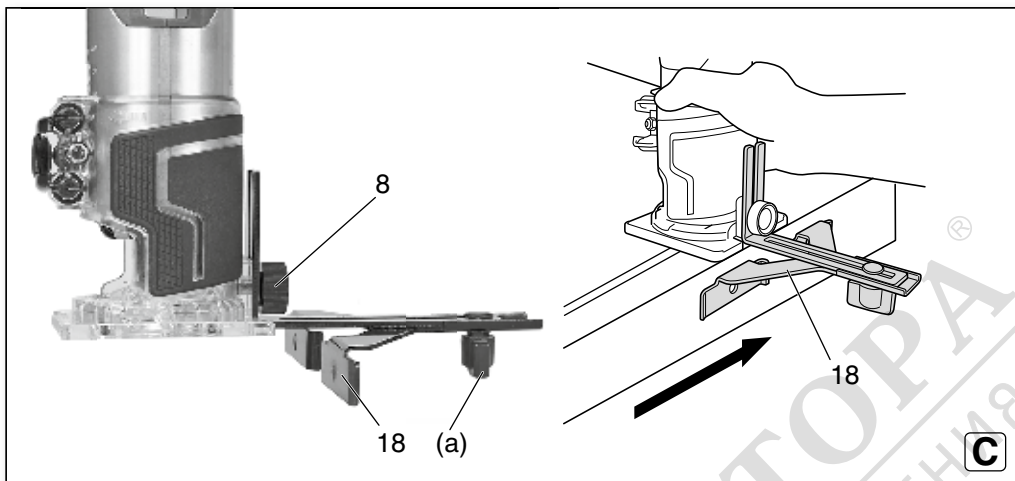

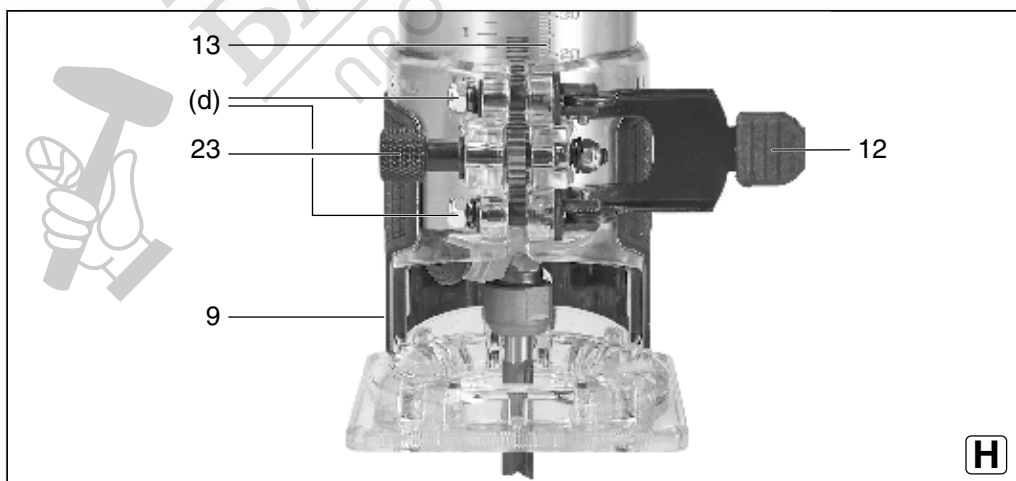
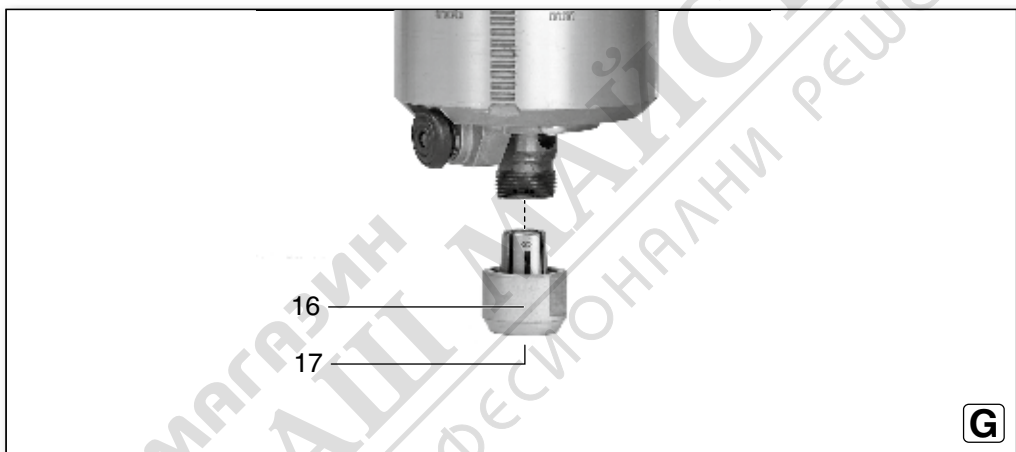
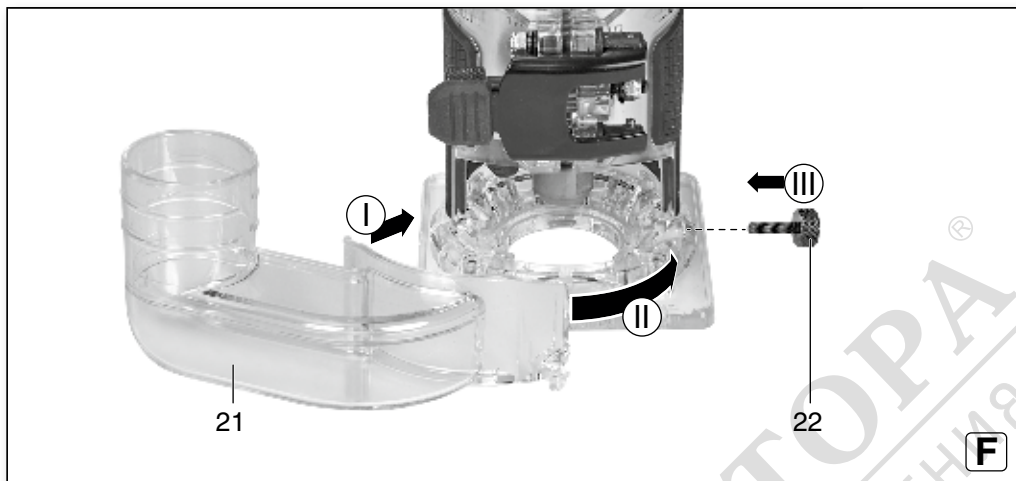

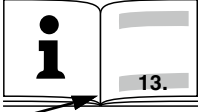

		FMV 18 LTX BL 8
*1) Serial Number		01742..
U	V	18
n₀	1/min (rpm)	4800 - 29000
H_{max}	mm (in)	40 (1 ⁹ / ₁₆)
d	mm (in)	8mm, 6mm / 1/4"
m	kg (lbs)	1,6 (3.5)
a_h/K_h	m/s²	< 2,5 / 1,5
L_{pA}/K_{pA}	dB(A)	81 / 3
L_{WA}/K_{WA}	dB(A)	89 / 3

	n₀ (/min)
1	4800
2	9600
3	14500
4	19300
5	24100
6	29000



*2) 2014/30/EU, 2006/42/EC, 2011/65/EU

*3) EN 62841-1:2015+A11:2022, EN 62841-2-17:2017, EN IEC 63000:2018

ppa. B.F.

2024-07-08, Bernd Fleischmann

Direktor Produktentstehung & Qualität (Vice President Product Engineering & Quality)

*4) Metabowerke GmbH - Metabo-Allee 1 - 72622 Nuertingen, Germany

Original instructions

1. Declaration of Conformity

We, being solely responsible: Hereby declare that these bevellers, identified by type and serial number *1), meet all relevant requirements of directives *2) and standards *3). Technical documents for *4) - see page 5.

For UK only:

UK We as manufacturer and authorized person to **CA** compile the technical file, see *4) on page 5, hereby declare under sole responsibility that these bevellers, identified by type and serial number *1) on page 5, fulfill all relevant provisions of following UK Regulations S.I. 2016/1091, S.I. 2008/1597, S.I. 2012/3032 and Designated Standards see *3) on page 5.

2. Specified Conditions of Use

The beveller is suited for cutting wood, wood-like materials and plastic.

The user bears sole responsibility for any damage caused by inappropriate use.

Generally accepted accident prevention regulations and the enclosed safety information must be observed.

3. General Safety Information



For your own protection and for the protection of your power tool, pay attention to all parts of the text that are marked with this symbol!



WARNING – Read the operating instructions to reduce the risk of injury.



WARNING – Read all safety warnings, instructions, illustrations and specifications provided with this power tool. Failure to follow all instructions listed below may result in electric shock, fire and/or serious injury.

Save all warnings and instructions for future reference.

Always include these documents when passing on your power tool.

4. Special Safety Instructions

4.1 Beveller safety warnings:

a) **Use clamps or another practical way to secure and support the workpiece to a stable platform.** Holding the workpiece by hand or against your body leaves it unstable and may lead to loss of control.

4.2 Additional safety instructions



Wear a suitable dust protection mask.



Wear ear protectors.



Wear protective goggles.

Remove the battery pack from the tool before any adjustments, conversions, servicing or cleaning are performed.

The clamping lever (12) must always be closed when working with the machine.

Do not try to machine extremely small workpieces.

Smaller workpieces must be secured in such a way that they do not get loose when working with the machine (e.g. using screw clamps).

Check the workpiece for foreign bodies. When working, always make sure that no nails or other similar materials are being cut into.

Keep your hands away from the rotating tool! Remove debris and similar material only when the machine is at a standstill.

Do not touch the cutter straight after use. It can be very hot and cause burns to your skin.

Danger of injury from the sharp edges of the cutter. If needed, set the stand all the way down for protection.

Press the spindle locking button only when the motor is at a standstill and the battery pack has been removed.

Materials that generate dusts or vapours that may be harmful to health (e.g. asbestos) must not be processed.

Connect a suitable extraction device.

Do not operate the machine in a holder.

LED light (11): do not observe the LED radiation directly with optical instruments.



CAUTION Do not stare at operating lamp.

Reducing dust exposure:



WARNING - Some dust created by power sanding, sawing, grinding, drilling, and other construction activities contains chemicals known to cause cancer, birth defects or other reproductive harm. Some examples of these chemicals are:

- Lead from lead-based paints,
- crystalline silica from bricks and cement and other masonry products, and
- arsenic and chromium from chemically treated lumber.

Your risk from these exposures varies, depending on how often you do this type of work. To reduce your exposure to these chemicals, work in a well-ventilated area, and work with approved safety equipment, such as those dust masks that are specially designed to filter out microscopic particles.

This also applies to dust from other materials, such as some timber types (like oak or beech dust), metals, asbestos. Other known diseases are e.g. allergic reactions, respiratory diseases. Do not let dust enter the body.

Observe the relevant guidelines and national regulations for your material, staff, application and place of application (e.g. occupational health and safety regulations, disposal).

Collect the particles generated at the source, avoid deposits in the surrounding area.

Use suitable accessories for special work. In this way, fewer particles enter the environment in an uncontrolled manner.

Use a suitable extraction unit.

Reduce dust exposure with the following measures:

- do not direct the escaping particles and the exhaust air stream towards yourself or nearby persons or towards dust deposits,
- use an extraction unit and/or an air purifier,
- ensure good ventilation of the workplace and keep it clean using a vacuum cleaner. Sweeping or blowing stirs up dust.
- Vacuum or wash protective clothing. Do not blow, beat or brush protective gear.

4.3 Special safety instructions for cordless tools:



Protect battery packs from water and moisture!



Do not expose battery packs to fire!

Do not use faulty or deformed battery packs!
Do not open battery packs!

Do not touch or short circuit battery pack contacts!



A slightly acidic, flammable fluid may leak from defective Li-Ion battery packs!



If battery fluid leaks out and comes into contact with your skin, rinse immediately with plenty of water. If battery fluid leaks out and comes into contact with your eyes, wash them with clean water and seek medical attention immediately!

If the machine is defective, remove the battery pack from the machine.

Transport of Li-Ion battery packs:

The shipping of Li-Ion battery packs is subject to laws related to the carriage of hazardous goods (UN 3480 and UN 3481). Inform yourself of the currently valid specifications when shipping Li-Ion battery packs. If necessary, consult your freight forwarder. Certified packaging is available from Metabo.

Only send the battery pack if the housing is intact and no fluid is leaking. Remove the battery pack from the machine for sending. Prevent the contacts from short-circuiting (e.g. by protecting them with adhesive tape).

5. Overview

See pages 2 to 4.

- 1 On/off switch
- 2 Battery pack release button
- 3 Battery pack*
- 4 Capacity indicator button *
- 5 Capacity and signal indicator *
- 6 Grip surface
- 7 Arrow (shows the direction of rotation of the cutter)
- 8 Screw
- 9 Base (cutting depth)
- 10 Footplate
- 11 LED light (worklight) / electronic signal display
- 12 Clamping lever (cutting depth)
- 13 Scale (cutting depth)
- 14 Speed adjustment wheel
- 15 Spindle locking button (to lock the milling spindle)
- 16 Collet chuck nut *
- 17 Collet chuck *
- 18 Parallel stop
- 19 Stop with guide roller
- 20 Template followers
- 21 Extraction nozzle (for chip extraction)
- 22 Clamping screw (extraction nozzle)
- 23 Setting screw (cutting depth)

*equipment-specific

6. Initial Operation and Setting

6.1 Inserting the cutter



The high speed of the machine requires high-quality cutters (HSS or carbide).



Only use cutters that are suited to the speed of your machine. See chapter "Technical data".



Only use cutters the shaft diameter of which matches the collet bore of the collet chuck.



The collet chuck nut may only be tightened by hand if no cutters are used.



Do not use blunt or damaged cutters.

1. Remove battery pack.
2. Open the clamping lever (12) and pull the stand (9) downwards to remove.

See fig. A:

3. Push the cutter into the collet chuck (17) until the entire cylindrical part of its shaft is enclosed by the collet chuck (17).
4. Locking the milling spindle: Push spindle locking button (15) and keep pressed. Slowly turn the collet chuck nut (16) until the lock engages.
5. Firmly tighten the collet chuck nut (16) using the 17 mm open-end wrench provided for this purpose.
6. Release the spindle locking button (15).
7. Replace the stand (9).

6.2 Adjusting the cutting depth

 Clean and safe cutting is achieved with a maximum cutting depth of 6 mm. This also protects the motor from overloading. Greater cutting depths can be achieved with several rounds.

See figure H:

1. Remove battery pack.
2. Opening the clamping lever (12)
3. By turning the adjusting screw (23) set the stand (9) in such a way that the cutter touches the workpiece surface very lightly.
4. Watch the scale (13) and adjust the stand (23) by turning the adjusting screw (9) to the desired cutting depth.
5. Closing the clamping lever (12) to secure the stand (9)

Note: If necessary, adjust the clamping force of the clamping lever (12) by evenly turning the 2 nuts (d). **See fig. H.** When the clamping lever (12) is closed, it must not be possible to move the stand (9).

6.3 Setting speed

The speed can be set using the thumb-wheel (14).
Speeds when idle, see table, page 5.

6.4 Attach the chip extraction

If an extraction unit is used, attach the extraction nozzle (21). **See fig. F.**

1. Remove battery pack.
2. Attach the extraction nozzle (21) as shown on the machine.
3. Secure with clamping screw (22).
4. To extract the saw chips, connect a suitable extraction unit with suction hose to the connection piece.

6.5 Replacing the collet chuck

See fig. G.

1. Remove battery pack.
2. Unscrew the collet chuck nut (16)
3. Replace the collet chuck (17) with the other collect chuck supplied.
4. Screw on the collet chuck (16) only by hand, do not tighten.

6.6 Battery pack

Charge the battery pack (3) before use.

Recharge the battery pack if performance diminishes.

Instructions on charging the battery pack can be found in the operating instructions of the Metabo charger.

Battery packs have a capacity and signal indicator (5) (depends on design variant):

- Press the button (4), the LEDs indicate the charge level.
- The battery pack is almost empty and must be recharged if one LED is flashing.

Removing and inserting the battery pack

Removing:

Press the battery pack release (2) button and remove the battery pack (3).

Inserting:

Slide in the battery pack (3) until it engages.

7. Use

7.1 Switching on and off

Activate on/off switch (1) .

I = switch on
0 = switch off

7.2 Working Directions

Machine use

 Firmly hold the machine from the grip surface (6).

Place the machine onto the workpiece without the cutter touching the workpiece. Switch on machine and wait until the full speed has been reached. Only then allow the cutter to penetrate the workpiece. The footplate (10) glides onto the workpiece.

Feed direction

Always work in the opposite direction. Always push the machine forwards as shown. See fig. B.

The direction of rotation of the cutter is indicated by an arrow (7) on the machine.

Guide the machine evenly at a speed suitable for the material being processed.

7.3 Putting down after use

After ending the cutting process, switch off the machine and only set it down when the motor has come to a standstill.

7.4 Special working methods:

Cutting with parallel guide (fig. C)

1. Attach the parallel guide (18) with screws (8) on the machine.
2. Undo the wing screw (a) and adjust the distance to the cutter. Tighten the wing screw (a).

Stop with guide bearings (see fig. D)

The stop with guide bearings (19) is used for cutting along a curved edge

1. Attach the stop (19) with the screw (8) to the machine.
2. Undo the clamping screw (a).
3. Using the adjusting screw (b), set the desired distance to the cutter.
4. Tighten the clamping screw (a).

Template follower (see fig. E)

For cutting according to a template fixed on the workpiece.

1. Open the clamping lever (12) and pull the stand (9) downwards to remove.
2. Insert the template follower (20) as shown and fix with 2 screws (a).
3. Replace the stand (9).
4. Attach a template (b) on the workpiece (c). Place the machine on the template and guide it so that the template follower (20) glides along the edge of the template (b).

Milling along a strip attached to the workpiece / milling along a straight marking

1. Attach a strip on the workpiece and guide the machine with a straight edge of the foot plate along the strip. (Always use the same edge.)

Profile milling

1. When working with profile cutters, first remove a larger chip and then a smaller chip.
2. The feed rate must not be too low, otherwise the wood will scorch and the cutter will become prematurely blunt.

8. Cleaning, Maintenance



Remove battery pack.

Dust deposits must be regularly removed from the machine. This includes vacuum cleaning the ventilation louvres on the motor.

9. Troubleshooting

Continuous beeping, the electronic signal indicator (11) flashes and the machine will not run:

Overload protection:

The overload protection protects the motor from overheating. Switch the machine off and then on again and continue to work with smaller feed or reduced cutting depth.

Continuous double beep, the electronic signal indicator (11) flashes and the machine will not run:

Restart protection

Restart protection is active. The machine will not start if the battery pack is inserted while the machine is on. Switch the machine off and back on again.

Continuous 4 beep cycle, the electronic signal indicator (11) flashes:

Battery pack almost empty / battery pack empty.

Charge battery pack.

10. Accessories

Use only original Metabo or CAS (Cordless Alliance System) battery packs and accessories.

Use only accessories that fulfil the requirements and specifications listed in these operating instructions.

Chargers: ASC 145, etc.

Battery packs with different capacities. Buy battery packs only with voltage suitable for your power tool.

4.0 Ah (LiHD), order no.: 625367000

5.5 Ah (LiHD), order no.: 625368000
etc.

5.2 Ah (Li-Ion), order no.: 625028000
etc.

See www.metabo.com or the catalogue for a complete range of accessories.

11. Repairs



Repairs to electrical tools must only be carried out by qualified electricians!

Contact your local Metabo representative if you have Metabo power tools requiring repairs. For addresses see www.metabo.com.

You can download a list of spare parts from www.metabo.com.

12. Environmental Protection

Observe national regulations on environmentally compatible disposal and on the recycling of disused machines, packaging and accessories.

Packaging materials must be disposed of according to their labelling in accordance with municipal guidelines. Further information can be found at www.metabo.com in the "Service" section.

Battery packs may not be disposed of with regular waste. Return faulty or used battery packs to your Metabo dealer!

Do not allow battery packs to come into contact with water!



Only for EU countries: never dispose of power tools in your household waste!

According to European Directive 2012/19/EU on Waste from Electric and Electronic Equipment and implementation in national law, used power tools must be collected separately and recycled in an environmentally-friendly manner.

Discharge the battery pack in the power tool before disposal. Prevent the contacts from short-circuiting (e.g. by protecting them with adhesive tape).

13. Technical Specifications

Explanatory notes regarding the specifications on page 5.

Subject to change in accordance with technical progress.

U = Voltage of battery pack

n_0 = Idle speed

H_{max} = max. stroke height

d = collet bore of the supplied collet chuck (specific to country / depending on features)

m = weight (with the smallest battery pack)

Measured values determined in conformity with EN 62841.

Permitted ambient temperature during operation: 0 °C (-4°F) to 40 °C (120 °F) (limited performance with temperatures below 0 °C (32°F)). Permitted ambient temperature for storage: 0 °C (32°F) to 30 °C (86°F).

Recommended ambient temperature when charging: 0 °C to 40 °C.

== direct current

The technical specifications quoted are subject to tolerances (in compliance with relevant valid standards).

Emission values

These values make it possible to assess the emissions from the power tool and to compare different power tools. The actual load may be higher or lower depending on operating conditions, the condition of the power tool or the accessories used. Please allow for breaks and periods when the load is lower for assessment purposes. Arrange protective measures for the user, such as organisational measures based on the adjusted estimates.

Vibration total value (vector sum of three directions) determined in accordance with EN 62841:

a_h = Vibration emission value without load
 K_h = Uncertainty (vibration)

Typical A-effective perceived sound levels:

L_{pA} = Sound pressure level
 L_{WA} = Acoustic power level
 K_{pA}, K_{WA} = Uncertainty

The noise level can exceed 80 dB(A) during operation.

Wear ear protection!



МАГАЗИН
 БАШ МАЙСТОРА®
 ПРОФЕСИОНАЛНИ РЕШЕНИЯ