

**HIKOKI**

**W 18DA · W 18DB**

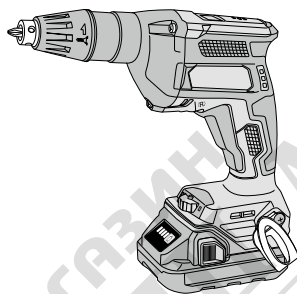

W18DA

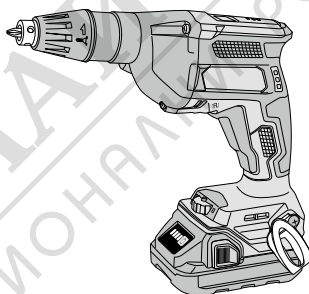

W18DB



Handling instructions

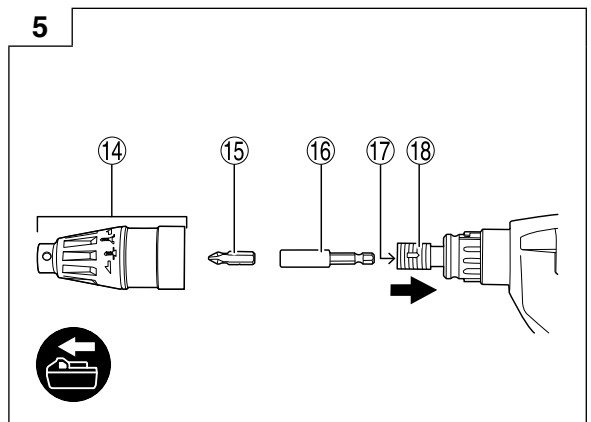
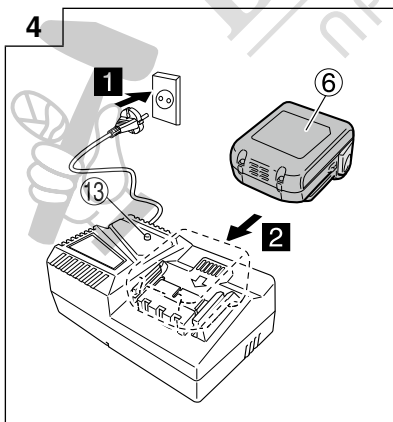
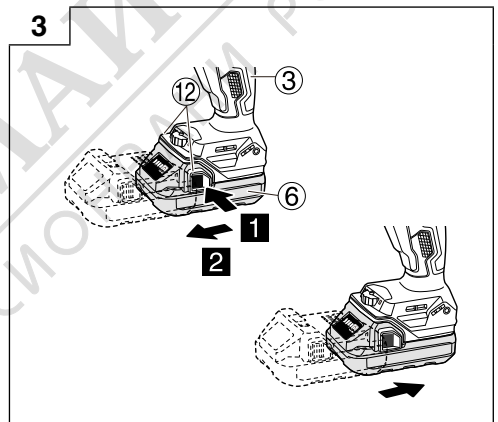
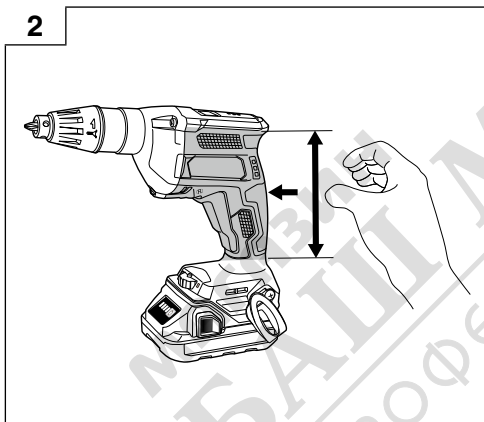
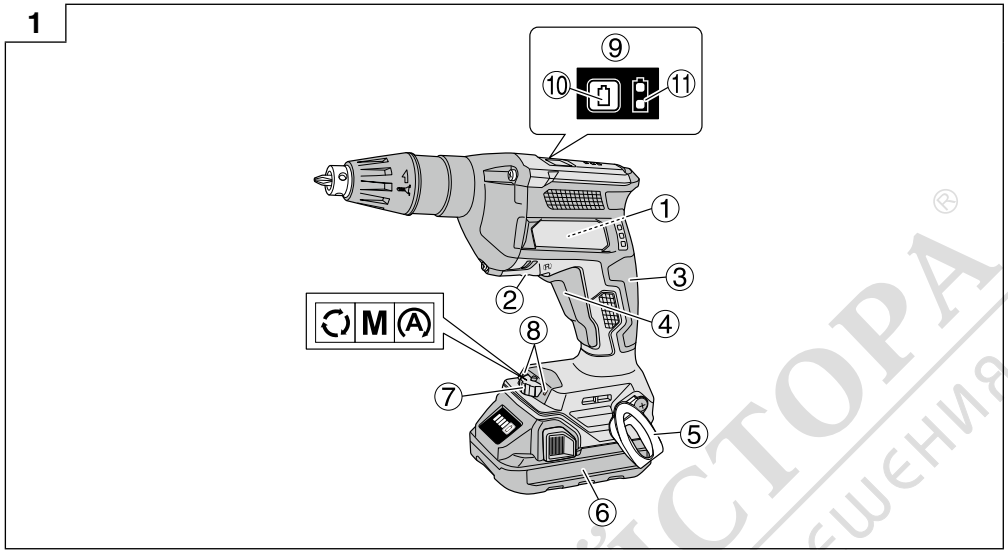

6

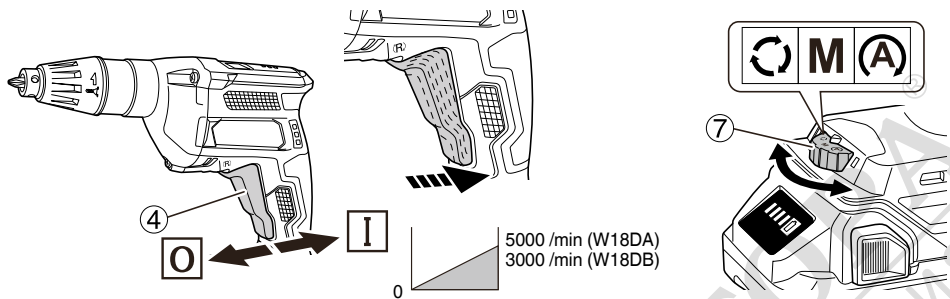

7

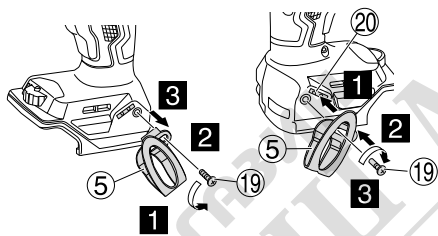

8

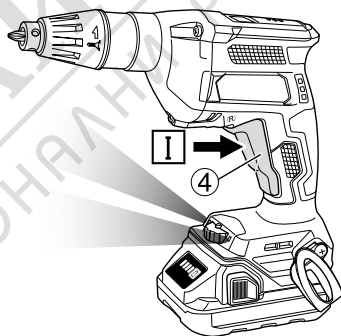

9

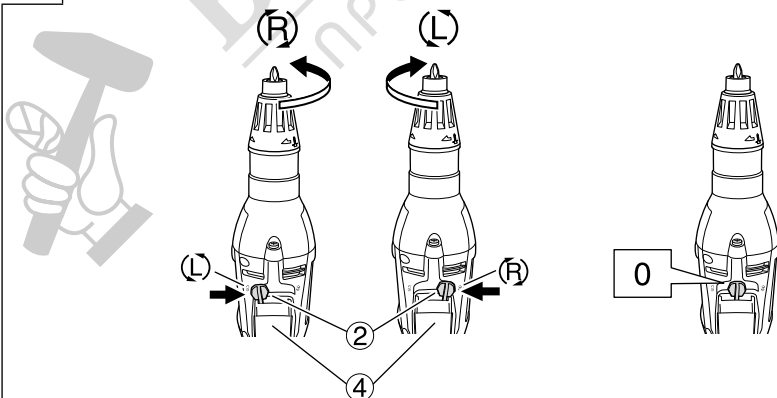

10

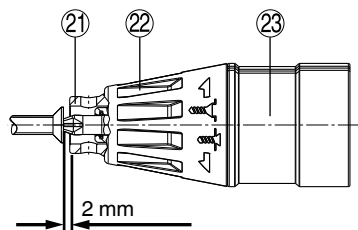

11

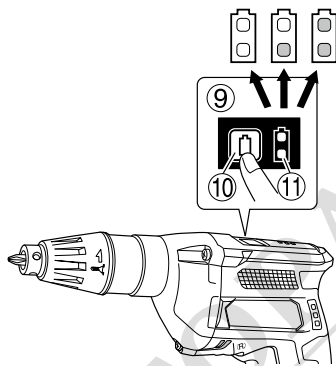

12

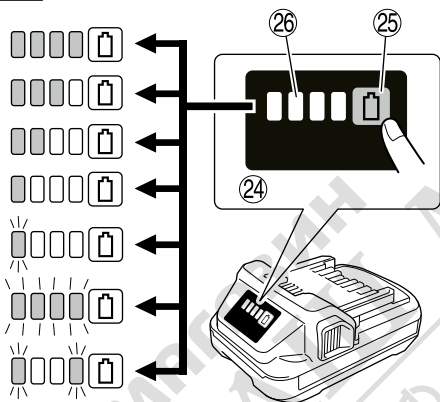

## GENERAL POWER TOOL SAFETY WARNINGS

### WARNING

Read all safety warnings, instructions, illustrations and specifications provided with this power tool.

Failure to follow all instructions listed below may result in electric shock, fire and/or serious injury.

Save all warnings and instructions for future reference.

The term "power tool" in the warnings refers to your mains-operated (corded) power tool or battery-operated (cordless) power tool.

#### 1) Work area safety

- a) **Keep work area clean and well lit.**  
*Cluttered or dark areas invite accidents.*
- b) **Do not operate power tools in explosive atmospheres, such as in the presence of flammable liquids, gases or dust.**  
*Power tools create sparks which may ignite the dust or fumes.*
- c) **Keep children and bystanders away while operating a power tool.**  
*Distractions can cause you to lose control.*

#### 2) Electrical safety

- a) **Power tool plugs must match the outlet. Never modify the plug in any way. Do not use any adapter plugs with earthed (grounded) power tools.**  
*Unmodified plugs and matching outlets will reduce risk of electric shock.*
- b) **Avoid body contact with earthed or grounded surfaces, such as pipes, radiators, ranges and refrigerators.**  
*There is an increased risk of electric shock if your body is earthed or grounded.*
- c) **Do not expose power tools to rain or wet conditions.**  
*Water entering a power tool will increase the risk of electric shock.*
- d) **Do not abuse the cord. Never use the cord for carrying, pulling or unplugging the power tool. Keep cord away from heat, oil, sharp edges or moving parts.**  
*Damaged or entangled cords increase the risk of electric shock.*
- e) **When operating a power tool outdoors, use an extension cord suitable for outdoor use.**  
*Use of a cord suitable for outdoor use reduces the risk of electric shock.*
- f) **If operating a power tool in a damp location is unavoidable, use a residual current device (RCD) protected supply.**  
*Use of an RCD reduces the risk of electric shock.*

#### 3) Personal safety

- a) **Stay alert, watch what you are doing and use common sense when operating a power tool. Do not use a power tool while you are tired or under the influence of drugs, alcohol or medication.**  
*A moment of inattention while operating power tools may result in serious personal injury.*
- b) **Use personal protective equipment. Always wear eye protection.**  
*Protective equipment such as a dust mask, non-skid safety shoes, hard hat or hearing protection used for appropriate conditions will reduce personal injuries.*

- c) **Prevent unintentional starting. Ensure the switch is in the off-position before connecting to power source and/or battery pack, picking up or carrying the tool.**

*Carrying power tools with your finger on the switch or energising power tools that have the switch on invites accidents.*

- d) **Remove any adjusting key or wrench before turning the power tool on.**

*A wrench or a key left attached to a rotating part of the power tool may result in personal injury.*

- e) **Do not overreach. Keep proper footing and balance at all times.**

*This enables better control of the power tool in unexpected situations.*

- f) **Dress properly. Do not wear loose clothing or jewellery. Keep your hair and clothing away from moving parts.**

*Loose clothes, jewellery or long hair can be caught in moving parts.*

- g) **If devices are provided for the connection of dust extraction and collection facilities, ensure these are connected and properly used.**

*Use of dust collection can reduce dust-related hazards.*

- h) **Do not let familiarity gained from frequent use of tools allow you to become complacent and ignore tool safety principles.**

*A careless action can cause severe injury within a fraction of a second.*

#### 4) Power tool use and care

- a) **Do not force the power tool. Use the correct power tool for your application.**  
*The correct power tool will do the job better and safer at the rate for which it was designed.*
- b) **Do not use the power tool if the switch does not turn it on and off.**  
*Any power tool that cannot be controlled with the switch is dangerous and must be repaired.*
- c) **Disconnect the plug from the power source and/or remove the battery pack, if detachable, from the power tool before making any adjustments, changing accessories, or storing power tools.**  
*Such preventive safety measures reduce the risk of starting the power tool accidentally.*
- d) **Store idle power tools out of the reach of children and do not allow persons unfamiliar with the power tool or these instructions to operate the power tool.**  
*Power tools are dangerous in the hands of untrained users.*
- e) **Maintain power tools and accessories. Check for misalignment or binding of moving parts, breakage of parts and any other condition that may affect the power tool's operation. If damaged, have the power tool repaired before use.**  
*Many accidents are caused by poorly maintained power tools.*
- f) **Keep cutting tools sharp and clean.**  
*Properly maintained cutting tools with sharp cutting edges are less likely to bind and are easier to control.*
- g) **Use the power tool, accessories and tool bits etc. in accordance with these instructions, taking into account the working conditions and the work to be performed.**  
*Use of the power tool for operations different from those intended could result in a hazardous situation.*

- h) **Keep handles and grasping surfaces dry, clean and free from oil and grease.**

*Slippery handles and grasping surfaces do not allow for safe handling and control of the tool in unexpected situations.*

**5) Battery tool use and care**

- a) **Recharge only with the charger specified by the manufacturer.**

*A charger that is suitable for one type of battery pack may create a risk of fire when used with another battery pack.*

- b) **Use power tools only with specifically designated battery packs.**

*Use of any other battery packs may create a risk of injury and fire.*

- c) **When battery pack is not in use, keep it away from other metal objects, like paper clips, coins, keys, nails, screws or other small metal objects, that can make a connection from one terminal to another.**

*Shorting the battery terminals together may cause burns or a fire.*

- d) **Under abusive conditions, liquid may be ejected from the battery; avoid contact. If contact accidentally occurs, flush with water. If liquid contacts eyes, additionally seek medical help.**

*Liquid ejected from the battery may cause irritation or burns.*

- e) **Do not use a battery pack or tool that is damaged or modified.**

*Damaged or modified batteries may exhibit unpredictable behaviour resulting in fire, explosion or risk of injury.*

- f) **Do not expose a battery pack or tool to fire or excessive temperature.**

*Exposure to fire or temperature above 130°C may cause explosion.*

- g) **Follow all charging instructions and do not charge the battery pack or tool outside the temperature range specified in the instructions.**

*Charging improperly or at temperatures outside the specified range may damage the battery and increase the risk of fire.*

**6) Service**

- a) **Have your power tool serviced by a qualified repair person using only identical replacement parts.**

*This will ensure that the safety of the power tool is maintained.*

- b) **Never service damaged battery packs.**

*Service of battery packs should only be performed by the manufacturer or authorized service providers.*

**PRECAUTION**

**Keep children and infirm persons away.**

**When not in use, tools should be stored out of reach of children and infirm persons.**

**CORDLESS SCREW DRIVER SAFETY WARNINGS**

1. **Hold the power tool by insulated gripping surfaces, when performing an operation where the fastener may contact hidden wiring.**

*Fasteners contacting a "live" wire may make exposed metal parts of the power tool "live" and could give the operator an electric shock.*

**ADDITIONAL SAFETY WARNINGS**

1. This is a portable tool for tightening and loosening screws. Use it only for these operation.
2. Make sure to securely hold the tool during operation. Failure to do so can result in accidents or injuries. (Fig. 2)
3. Preparing and checking the work environment. Make sure that the work site meets all the conditions laid forth in the precautions.
4. Stop the tool before switching the direction of rotation. Always release the switch and wait for tool to stop before switching the direction of rotation.
5. Never touch the turning part. Do not allow the turning part section to get near your hands or any other part of your body. You could be cut or caught in the turning part. Also, be careful not to touch the turning part after using continuously it for a long time. It gets quite hot and could burn you.
6. Please use the designated attachments which are listed in the operations manual and HiKOKI's catalog. Accidents or injuries could result from not doing so.
7. After installing the driver bit, pull lightly out the bit to make sure that it does not come loose. If the bit is not installed properly, it can come loose during use, which can be dangerous.
8. Screw in screws with the main unit held straight. If the driver is slanted relative to the screw, the screw head can be damaged and the bit worn. Moreover, the prescribed torque is not transmitted to the screw, resulting in screws left sticking out. Place the drive straight against the screw and screw in.
9. Use the prescribed screws.  
Do not use any other screws. They can cause abnormal work (screws fallen over or sticking out) and break downs (screw jamming and bit wear).
10. Protect your eyes with protective glasses.  
Always wear protective glasses while working. Drilling scatters plaster powder and tape dust, which are dangerous if they get into your eyes
11. Watch out for wires and pipes in walls and ceilings.  
When working on floors, walls, or ceilings, check for wires and pipes ahead of time. Work carefully to avoid shocks and explosions.
12. Resting the unit after continuous work.
13. The motor may stop in the event the tool is overloaded. In this should occur, release the tool's switch and eliminate the cause of the overload.  
Avoid touching the front case which can heat up during continuous operation.
14. Do not touch the metal parts, as it gets very hot during continuous work.
15. The use of the battery in a cold condition (below 0 degree Centigrade) can sometimes result in the weakened tightening torque and reduced amount of work. This, however, is a temporary phenomenon, and returns to normal when the battery warms up.
16. Do not look directly into the light. Such actions could result in eye injury.  
Wipe off any dirt or grime attached to the lens of the LED light with a soft cloth, being careful not to scratch the lens.  
Scratches on the lens of the LED light can result in decreased brightness.
17. Install securely the hook. Unless the hook is securely installed, it may cause an injury while using.  
When electing to carry the tool hooked to your hip belt, make sure to detach the tool bit. Failure to do so may result in unexpected injury.
18. Always use the tool and battery at temperatures between -5°C and 40°C.

19. Always charge the battery at an ambient temperature of 0°C–40°C.
  20. Do not allow foreign matter to enter the hole for connecting the rechargeable battery.
  21. Never disassemble the rechargeable battery and charger.
  22. Never short-circuit the rechargeable battery. Short-circuiting the battery will cause a great electric current and overheat. It results in burn or damage to the battery.
  23. Do not dispose of the battery in fire. If the battery is burnt, it may explode.
  24. Bring the battery to the shop from which it was purchased as soon as the post-charging battery life becomes too short for practical use. Do not dispose of the exhausted battery.
  25. Do not insert object into the air ventilation slots of the charger. Inserting metal objects or inflammables into the charger air ventilation slots will result in electrical shock hazard or damaged charger.
  26. Do not use the charger continuously.  
When one charging is completed, leave the charger for about 15 minutes before the next charging of battery.
  27. When using this unit continuously, the unit may overheat, leading to damage in the motor and switch. Therefore, whenever the housing becomes hot, give the tool a break for a while.
  28. Make sure that the battery is installed firmly. If it is as all loose it could come off and cause an accident.
  29. Do not use the product if the tool or the battery terminals (battery mount) are deformed.  
Installing the battery could cause a short circuit that could result in smoke emission or ignition.
  30. Keep the tool's terminals (battery mount) free of swarf and dust.
    - Prior to use, make sure that swarf and dust have not collected in the area of the terminals.
    - During use, try to avoid swarf or dust on the tool from falling on the battery.
    - When suspending operation or after use, do not leave the tool in an area where it may be exposed to falling swarf or dust.  
Doing so could cause a short circuit that could result in smoke emission or ignition.
- Make sure that any swarf and dust falling on the power tool during work do not collect on the battery.
  - Do not store an unused battery in a location exposed to swarf and dust.
  - Before storing a battery, remove any swarf and dust that may adhere to it and do not store it together with metal parts (screws, nails, etc.).
2. Do not pierce battery with a sharp object such as a nail, strike with a hammer, step on, throw or subject the battery to severe physical shock.
  3. Do not use an apparently damaged or deformed battery.
  4. Do not use the battery for a purpose other than those specified.
  5. If the battery charging fails to complete even when a specified recharging time has elapsed, immediately stop further recharging.
  6. Do not put or subject the battery to high temperatures or high pressure such as into a microwave oven, dryer, or high pressure container.
  7. Keep away from fire immediately when leakage or foul odor are detected.
  8. Do not use in a location where strong static electricity generates.
  9. If there is battery leakage, foul odor, heat generated, discolored or deformed, or in any way appears abnormal during use, recharging or storage, immediately remove it from the equipment or battery charger, and stop use.
  10. Do not immerse the battery or allow any fluids to flow inside. Conductive liquid ingress, such as water, can cause damage resulting in fire or explosion. Store your battery in a cool, dry place, away from combustible and flammable items. Corrosive gas atmospheres must be avoided.

#### CAUTION

1. If liquid leaking from the battery gets into your eyes, do not rub your eyes and wash them well with fresh clean water such as tap water and contact a doctor immediately.  
If left untreated, the liquid may cause eye-problems.
2. If liquid leaks onto your skin or clothes, wash well with clean water such as tap water immediately.  
There is a possibility that this can cause skin irritation.
3. If you find rust, foul odor, overheating, discolor, deformation, and/or other irregularities when using the battery for the first time, do not use and return it to your supplier or vendor.

### CAUTION ON LITHIUM-ION BATTERY

To extend the lifetime, the lithium-ion battery equips with the protection function to stop the output.

In the cases of 1 to 3 described below, when using this product, even if you are pulling the switch, the motor may stop. This is not the trouble but the result of protection function.

1. When the battery power remaining runs out, the motor stops.  
In such a case, charge it up immediately.
2. If the tool is overloaded, the motor may stop. In this case, release the switch of tool and eliminate causes of overloading. After that, you can use it again.
3. If the battery is overheated under overload work, the battery power may stop.  
In this case, stop using the battery and let the battery cool. After that, you can use it again.

Furthermore, please heed the following warning and caution.

#### WARNING

In order to prevent any battery leakage, heat generation, smoke emission, explosion and ignition beforehand, please be sure to heed the following precautions.

1. Make sure that swarf and dust do not collect on the battery.
- During work make sure that swarf and dust do not fall on the battery.

#### WARNING

If a conductive foreign matter enters in the terminal of lithium ion battery, the battery may be shorted, causing fire. When storing the lithium ion battery, obey surely the rules of following contents.

- Do not place conductive debris, nail and wires such as iron wire and copper wire in the storage case.
- To prevent shorting from occurring, load the battery in the tool or insert securely the battery cover for storing until the ventilator is not seen.

### REGARDING LITHIUM-ION BATTERY TRANSPORTATION

When transporting a lithium-ion battery, please observe the following precautions.

#### WARNING

Notify the transporting company that a package contains a lithium-ion battery, inform the company of its power output and follow the instructions of the transportation company when arranging transport.

- Lithium-ion batteries that exceed a power output of 100 Wh are considered to be in the freight classification of Dangerous Goods and will require special application procedures.
- For transportation abroad, you must comply with international law and the rules and regulations of the destination country.

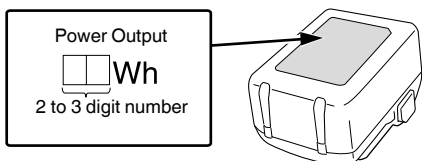

	Direct current
V	Rated voltage
$n_0$	No-load speed
/min	Oscillation per minute
	Disconnect the battery
I	Switching ON
O	Switching OFF
	Clockwise rotation
	Counterclockwise rotation
0	Centre position: with the transporting safety device engaged (switch-on lock)
M	Manual mode
	Automatic mode
	Impulse mode

## NAMES OF PARTS (Fig. 1–Fig. 12)

①	Motor	⑭	Stopper
②	Rotation selector switch	⑮	Bit
③	Handle	⑯	Magnetic bit holder
④	Trigger switch	⑰	Spindle
⑤	Hook	⑱	Closure sleeve
⑥	Battery	⑲	Screw
⑦	Dial	⑳	Groove
⑧	LED light	㉑	Stop sleeve
⑨	Switch panel	㉒	Setting sleeve
⑩	Remaining battery indicator switch (on tool body)	㉓	Union sleeve
⑪	Remaining battery indicator lamp (on tool body)	㉔	Display panel
⑫	Latch	㉕	Remaining battery indicator switch (on battery)
⑬	Pilot lamp	㉖	Remaining battery indicator lamp (on battery)

## Battery

	Remaining battery indicator switch
	Lights ; The battery remaining power is over 75%
	Lights ; The battery remaining power is 50%–75%.
	Lights ; The battery remaining power is 25%–50%.
	Lights ; The battery remaining power is less than 25%
	Blinks ; The battery remaining power is nearly empty. Recharge the battery soonest possible.
	Blinks ; Output suspended due to high temperature. Remove the battery from the tool and allow it to fully cool down.
	Blinks ; Output suspended due to failure or malfunction. The problem may be the battery so please contact your dealer.

## SYMBOLS

### WARNING

The following show symbols used for the machine. Be sure that you understand their meaning before use.

	W18DA / W18DB: Cordless Screw Driver
	To reduce the risk of injury, user must read instruction manual.

### NOTE

To prevent the battery power consumption caused by forgetting to turn off the LED light, the light goes off automatically in about 3 seconds.

## STANDARD ACCESSORIES

In addition to the main unit (1), the package contains the accessories listed on page 12. Standard accessories are subject to change without notice.

## SPECIFIED CONDITIONS OF USE

The tools are suitable for screwing into gypsum plasterboard on timber and metal substructures and gypsum fibre board up to 12.5 mm on metal substructures.

W18DB is also suitable for gypsum fibre board up to 12.5 mm on timber substructures and on lay plates, and for chipboard (OSB) on timber substructures.

The machines are not suitable for inserting and removing screws in metal materials.

The user bears sole responsibility for any damage caused by inappropriate use.

Generally accepted accident prevention regulations and the enclosed safety information must be observed.

## SPECIFICATIONS

### 1. Power tool

Model	W18DA	W18DB
Voltage	18 V	
No load speed	0–5000 /min	0–3000 /min
Screw size	4 mm	
Bit shank size	6.35 mm Hex.	
Battery available for this tool*	Multi volt battery, BSL18 series	
Weight	1.4 kg (BSL1820M)	1.5 kg (BSL1820M)

\* Existing batteries (BSL3660/3620/3626) cannot be used with this tool.

### NOTE

Due to HiKOKI's continuing program of research and development, the specifications herein are subject to change without prior notice.

### 2. Battery

Model	BSL1820M
Voltage	18 V
Battery capacity	2.0 A

## CHARGING

Before using the power tool, charge the battery as follows.

### 1. Connect the charger's power cord to the receptacle.

When connecting the plug of the charger to a receptacle, the pilot lamp will blink in red (At 1- second intervals).

### 2. Insert the battery into the charger.

Firmly insert the battery into the charger as shown in Fig. 4.

### 3. Charging





When inserting a battery in the charger, charging will commence and the pilot lamp will light continuously in red.

When the battery becomes fully recharged, the pilot lamp will blink in red. (At 1-second intervals) (See Table 1)

#### ● Pilot lamp indication

The indications of the pilot lamp will be as shown in Table 1, according to the condition of the charger or the rechargeable battery.

Table 1

Indications of the pilot lamp (RED)		
Before charging	Lights on for 0.5 seconds and off for 0.5 seconds Blinks 	Plugged into power source
While charging	Lights continuously Lights 	— ⊕
Charging complete	Lights on for 0.5 seconds and off for 0.5 seconds Blinks 	—
Overheat standby	Lights on for 1 second and off for 0.5 seconds Blinks 	Battery overheated. Unable to charge. (Charging will commence when battery cools)
Charging impossible	Lights on for 0.1 seconds and off for 0.1 seconds Flickers 	Malfunction in the battery or the charger

- Regarding the temperatures and charging time of the battery. The temperatures and charging time will become as shown in Table 2.

Table 2

Charger		UC18YFSL
Battery		
Charging voltage	V	14.4–18
Weight	kg	0.5
Temperatures at which the battery can be recharged		0°C–50°C
Charging time for battery capacity, approx. (At 20°C)		
1.5 Ah	min	22
2.0 Ah	min	30
2.5 Ah	min	35
3.0 Ah	min	45
4.0 Ah	min	60
5.0 Ah	min	75
6.0 Ah	min	90
8.0 Ah	min	120
Number of battery cells		4–10

### NOTE

The recharging time may vary according to temperature and power source voltage.

### CAUTION

When the battery charger has been continuously used, the battery charger will be heated, thus constituting the cause of the failures. Once the charging has been completed, give 15 minutes rest until the next charging.

4. Disconnect the charger's power cord from the receptacle.

5. Hold the charger firmly and pull out the battery.

**NOTE**

Be sure to pull out the battery from the charger after use, and then keep it.

**Regarding electric discharge in case of new batteries, etc.**

As the internal chemical substance of new batteries and batteries that have not been used for an extended period is not activated, the electric discharge might be low when using them the first and second time. This is a temporary phenomenon, and normal time required for recharging will be restored by recharging the batteries 2–3 times.

**How to make the batteries perform longer.**

(1) Recharge the batteries before they become completely exhausted.

When you feel that the power of the tool becomes weaker, stop using the tool and recharge its battery. If you continue to use the tool and exhaust the electric current, the battery may be damaged and its life will become shorter.

(2) Avoid recharging at high temperatures.

A rechargeable battery will be hot immediately after use. If such a battery is recharged immediately after use, its internal chemical substance will deteriorate, and the battery life will be shortened. Leave the battery and recharge it after it has cooled for a while.

**CAUTION**

- If the battery is charged while it is heated because it has been left for a long time in a location subject to direct sunlight or because the battery has just been used, the pilot lamp of the charger lights for 1 second, does not light for 0.5 seconds (off for 0.5 seconds). In such a case, first let the battery cool, then start charging.
- When the pilot lamp flickers (at 0.2-second intervals), check for and take out any foreign objects in the charger's battery connector. If there are no foreign objects, it is probable that the battery or charger is malfunctioning. Take it to your authorized Service Center.

## MOUNTING AND OPERATION

Action	Figure	Page
Removing and inserting the battery	3	2
Charging	4	2
Changing bit*1	5	2
Selection operating mode / Switch operation*2	6	3
Mounting and removing the hook	7	3
How to use the LED light*3	8	3
Setting the direction of rotation, engaging the transporting safety device (switch-on lock) *4	9	3
Working with stopper*5	10	4
Remaining battery indicator*6 (on tool body)	11	4
Remaining battery indicator (on battery)	12	4
Selecting accessories	—	13

### \*1 Changing bit

**WARNING**

Prevent inadvertent starting: Set manual mode and remove battery pack from the tool before performing any retooling.

**Inserting and removing the bit:**

Remove the stopper.

**Insert:** Insert the bit in the magnetic bit holder.

**Remove:** Pull the bit from the magnetic bit holder using pliers.

Attach the stopper again:

turn and engage in position when mounted.

**NOTE**

The magnetic bit holder may be removed from the spindle if the sleeve is pulled back.

### \*2 Selection operating mode, switch on / off

Set the required operating mode on the dial.

**NOTE**

When the motor is running, the spindle does not start until the spindle is pushed in.

### Manual mode

Switch on: press the trigger switch. Press in the trigger to increase the rotational speed.

To switch off release the trigger switch.

### Automatic mode

The tool starts automatically when the spindle is pushed in. This facilitates convenient work. In order to enable automatic mode, briefly press the trigger switch.

**NOTE**

The tool switches to sleep mode after 15 minutes without use. To activate again: press the trigger switch briefly.

**WARNING**

Risk of injury from inadvertent automatic machine start-up. In automatic mode, do not touch any rotating parts such as spindle, bit or magnetic bit holder.

### Impulse mode

Protruding screws can be precisely countersunk using this function. Press trigger switch and countersink the screw with the attached stopper. To switch off release the trigger switch.

**NOTE**

- If the amount of protrusion of the screw is small, the screw may not tighten.
- In that case, remove the stopper and make adjustments in Manual mode.

### \*3 How to use the LED light

**NOTE**

The light goes out automatically 10 seconds after the switch is released.

### \*4 Setting the direction of rotation, engaging the transporting safety device (switch-on lock)

**CAUTION**

Only activate the rotation selector switch when the motor has completely stopped.

### \*5 Working with stopper

The depth of screw can be set by turning the setting sleeve. On rotation of the knurled screw corresponds to a drill depth of around 1.5 mm.

Adjust the setting sleeve so that the screw head is approx. 2 mm outside the stop sleeve when applying the screw.

Insert a screw as a test. Correct the screw depth if necessary.

**CAUTION**

When screwing in crosshead screws, press the machine with the bit firmly against the screw until the screw is fully inserted; otherwise the bit could slip out of the cross recess and damage the material.

#### \*6 Remaining battery indicator (on tool body)

When using a battery with a remaining battery indicator, please refer to the indicator lamp on the battery for the battery remaining power.

## LED LIGHT WARNING SIGNALS

This product features functions that are designed to protect the tool itself as well as the battery. If any of the safeguard functions are activated during operation, the LED light will blink three times. (See **Table 3**) When any of the safeguard functions are triggered, immediately remove your finger from the switch and follow the instructions described under corrective action. After performing the corrective action, if the product does not operate when the trigger switch is pulled (or if the LED light blinks), remove the battery, wait for about 10 seconds, then insert the battery again.

**Table 3**

Safeguard Function	LED Light Display	Corrective Action
Overload Protection	Blinks three times.	Remove the cause of the overload.
Low Voltage Protection	■■■	Recharge the battery.

## MAINTENANCE AND INSPECTION

### WARNING

Be sure to turned off the switch and remove the battery before maintenance and inspection.

#### 1. Inspecting the bit

Since continued use of a worn bit may cause overloading of the motor. Replace the bit with a new one as soon as excessive wear is noticed.

#### 2. Clean stiff stopper

If the depth setting is stiff, the stopper can be dismantled without using tools. To do this, turn the setting sleeve clockwise until it becomes loose from the union sleeve. Twist out the stop sleeve and clean thread.

### NOTE

- Only clean or vacuum mechanically. Do not use oils or greases.
- Regularly remove and clean the stopper.

#### 3. Inspecting the mounting screws

Regularly inspect all mounting screws and ensure that they are properly tightened. Should any of the screws be loose, retighten them immediately. Failure to do so could result in serious hazard.

#### 4. Maintenance of the motor

The motor unit winding is the very "heart" of the power tool. Exercise due care to ensure the winding does not become damaged and/or wet with oil or water.

#### 5. Inspection of terminals (tool and battery)

Check to make sure that swarf and dust have not collected on the terminals.

On occasion check prior, during and after operation.

### CAUTION

Remove any swarf or dust which may have collected on the terminals.

Failure to do so may result in malfunction.

#### 6. Cleaning on the outside

When the power tool is stained, wipe with a soft dry cloth or a cloth moistened with soapy water. Do not use chloric solvents, gasoline or paint thinner, for they melt plastics. Particles may become deposited inside the power tool during operation. This impairs the cooling of the power tool.

The power tool should be cleaned regularly, often and thoroughly through all front and rear air vents using a vacuum cleaner. Prior to this operation, separate the power tool from the power source and wear protective goggles and a dust mask.

#### 7. Environmental protection

Observe national regulations on environmentally compatible disposal and on the recycling of disused machines, packaging and accessories.

#### 8. Storage

Store the impact driver and the battery in a place in which the temperature is less than 40°C and out of reach of children.

### NOTE

Storing lithium-ion batteries.

Make sure the lithium-ion batteries have been fully charged before storing them.

Prolonged storage (3 months or more) of batteries with a low charge may result in performance deterioration, significantly reducing battery usage time or rendering the batteries incapable of holding a charge.

However, significantly reduced battery usage time may be recovered by repeatedly charging and using the batteries two to five times.

If the battery usage time is extremely short despite repeated charging and use, consider the batteries dead and purchase new batteries.

### CAUTION

In the operation and maintenance of power tools, the safety regulations and standards prescribed in each country must be observed.

### Important notice on the batteries for the HIKOKI cordless power tools

Please always use one of our designated genuine batteries. We cannot guarantee the safety and performance of our cordless power tool when used with batteries other than these designated by us, or when the battery is disassembled and modified (such as disassembly and replacement of cells or other internal parts).

### NOTE

Due to HIKOKI's continuing program of research and development, the specifications herein are subject to change without prior notice.

	W18DA	W18DB
	(SC) (NN)	(NNP)
	1	—



МАГАЗИН  
**БАШ МАЙСТОРА**  
 ПРОФЕСІОНАЛНИ РЕШЕННЯ

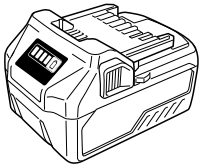

BSL36..18

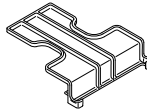

329897

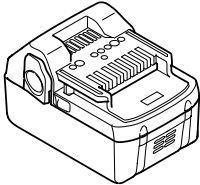

BSL18..

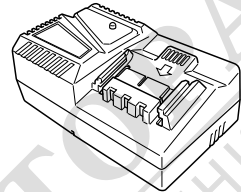
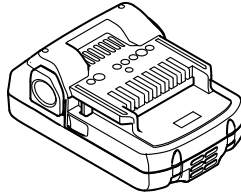

UC18YFSL (14.4 V-18 V)

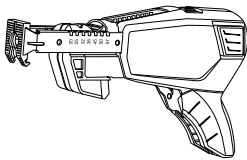

378857

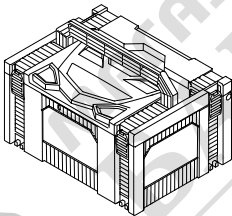

337108



378740





МАГАЗИН  
**БАШ МАЙСТОРА**<sup>®</sup>  
ПРОФЕССИОНАЛНИ РЕШЕНИЯ

## Koki Holdings Co., Ltd.

Shinagawa Intercity Tower A, 15-1, Konan 2-chome,  
Minato-ku, Tokyo, Japan