

**HIKOKI**

**DH 1826DA • DH 1826DC**

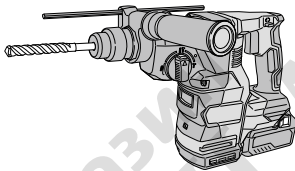

DH1826DA

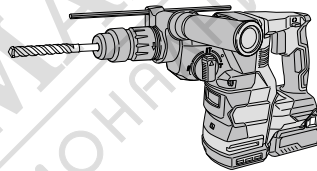

DH1826DC



Handling instructions

1

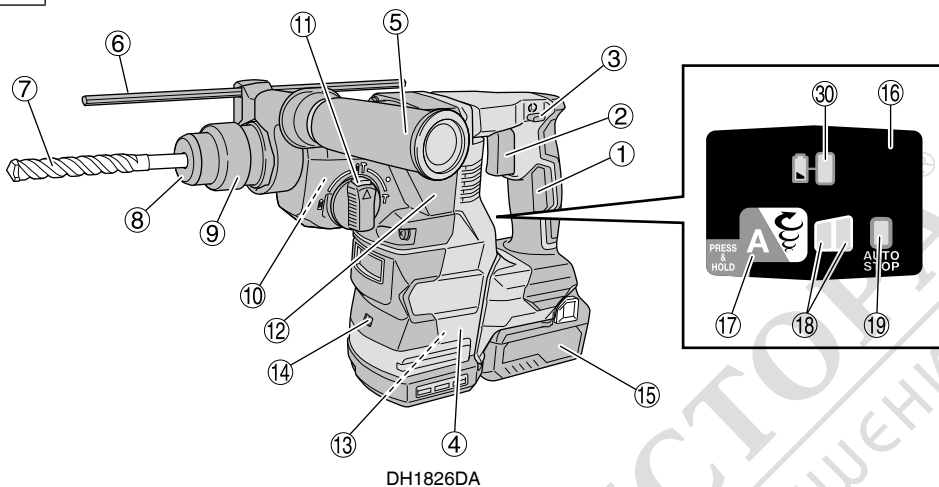

DH1826DA

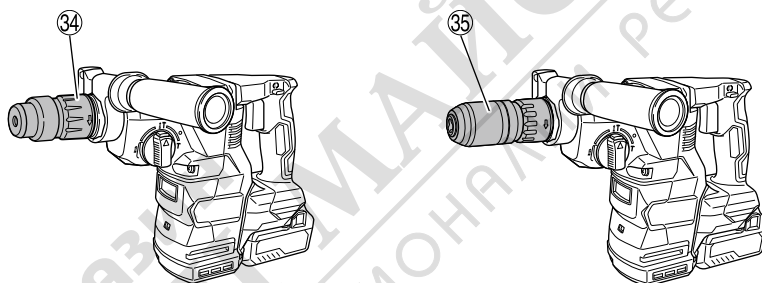

DH1826DC

2

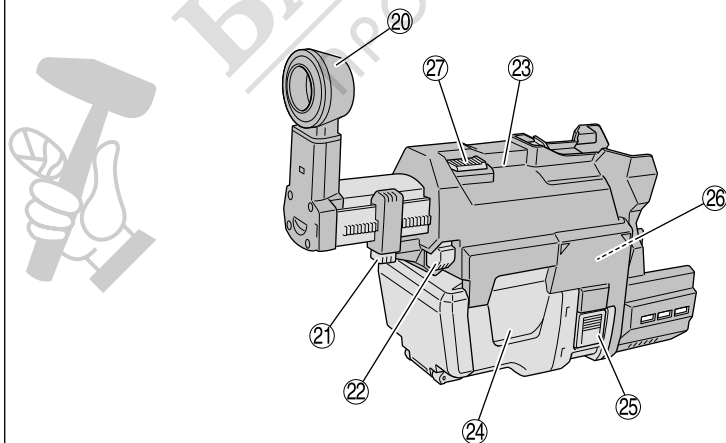

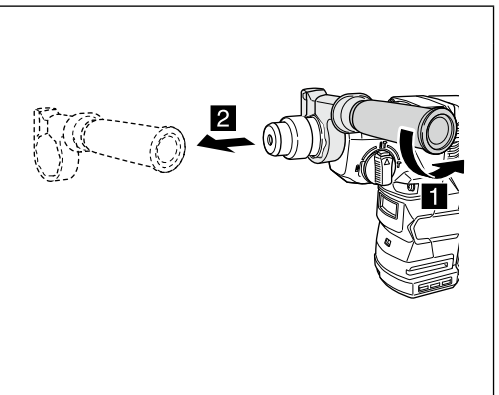
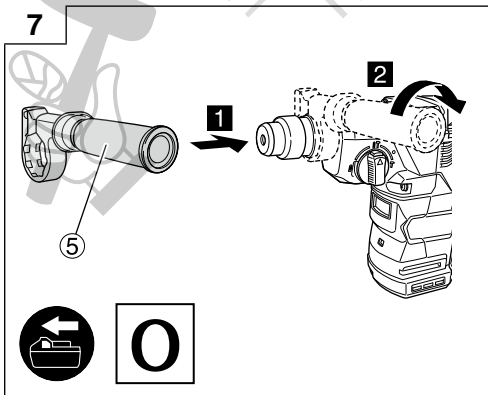
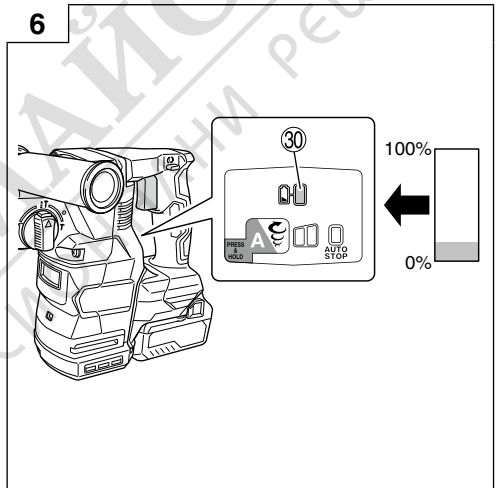
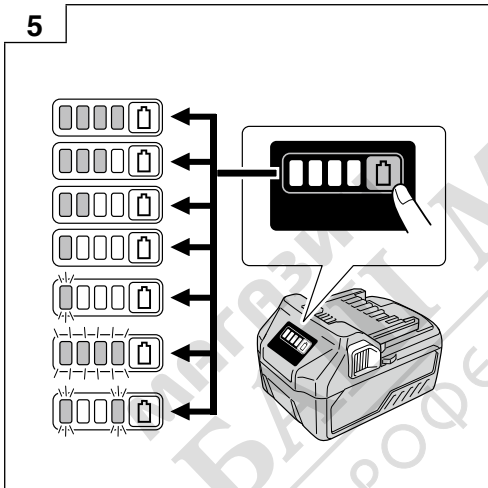
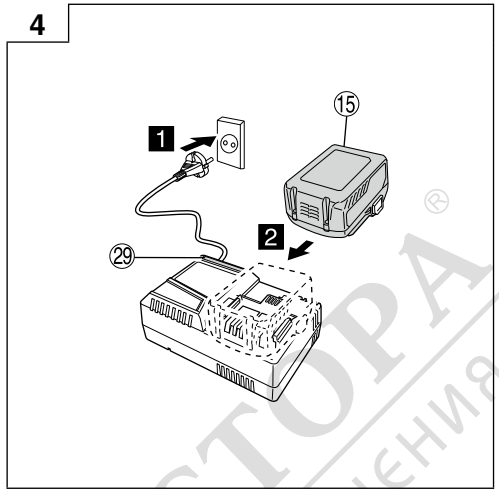
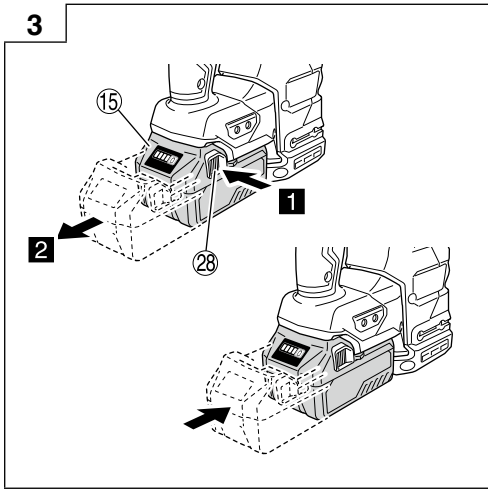

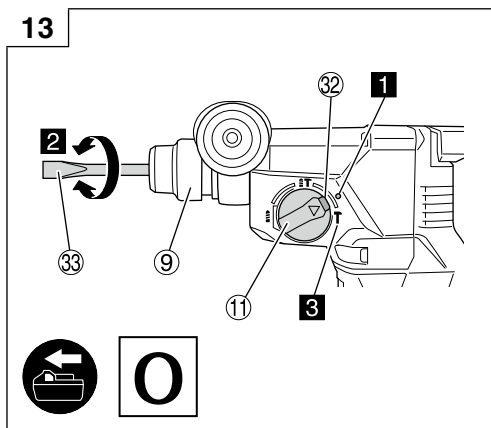
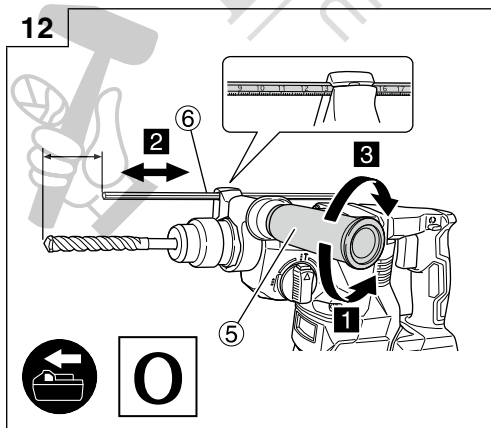
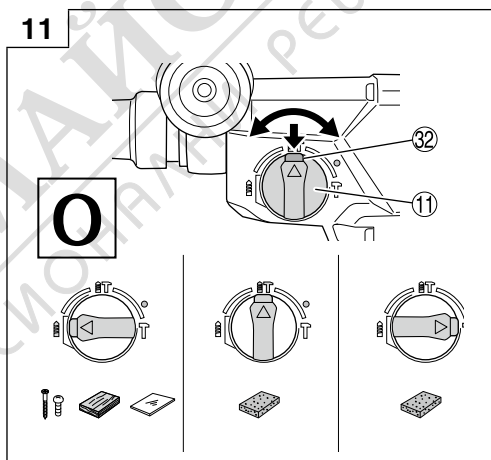
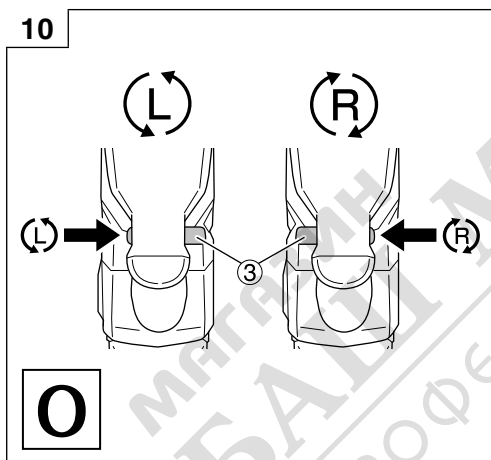
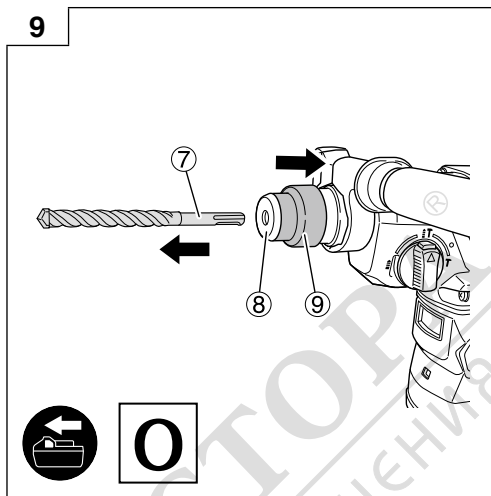
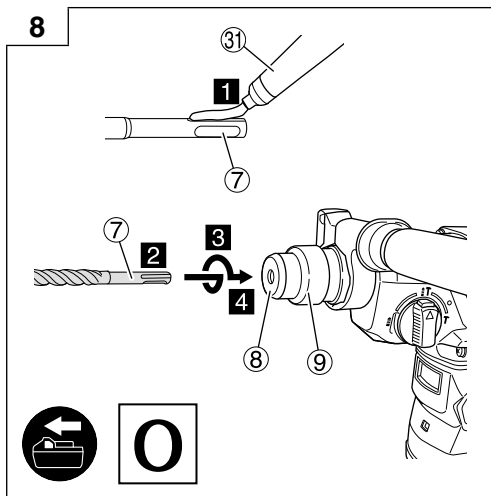

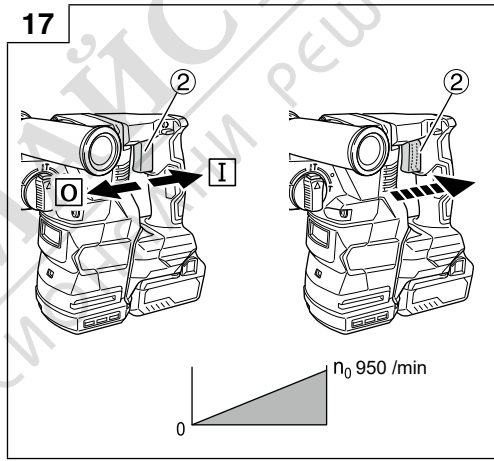
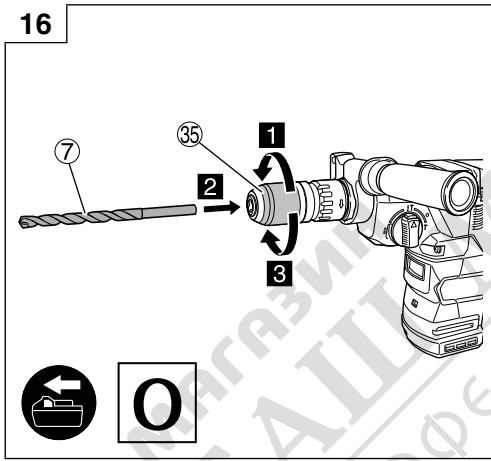
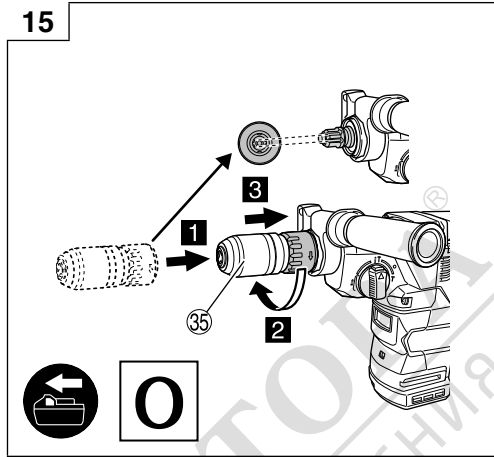
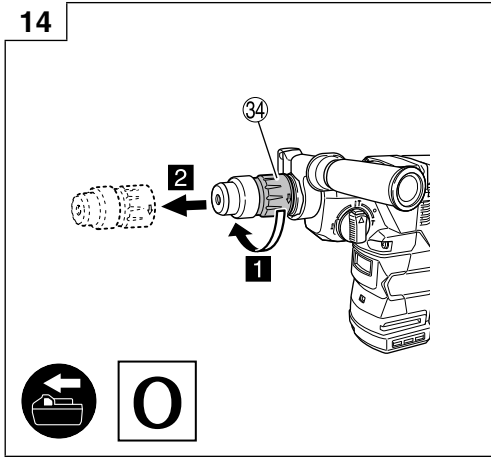

18

17

$n_0$	700	950
Bpm	3170	4300

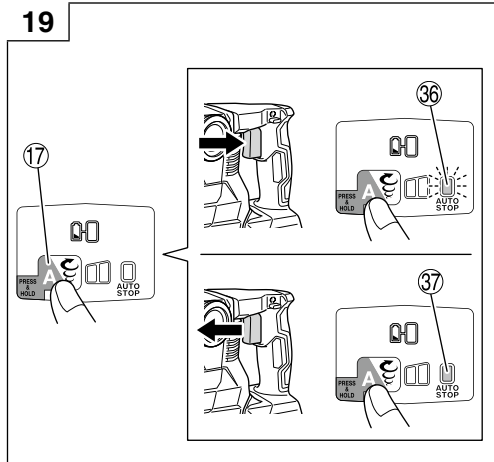

20

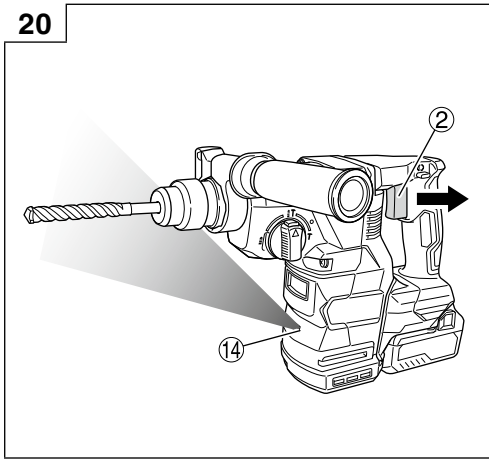

21

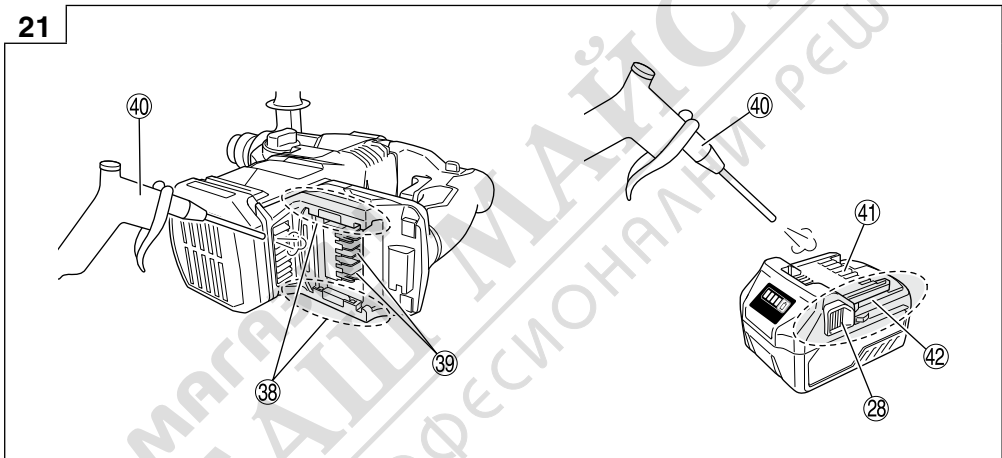

22

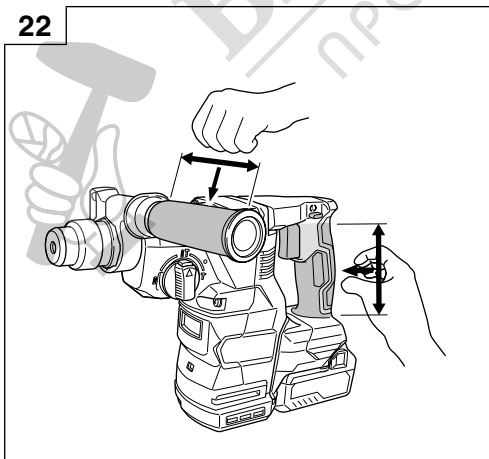

## GENERAL POWER TOOL SAFETY WARNINGS

### WARNING

Read all safety warnings, instructions, illustrations and specifications provided with this power tool.

Failure to follow all instructions listed below may result in electric shock, fire and/or serious injury.

Save all warnings and instructions for future reference.

The term "power tool" in the warnings refers to your mains-operated (corded) power tool or battery-operated (cordless) power tool.

#### 1) Work area safety

- a) **Keep work area clean and well lit.**  
*Cluttered or dark areas invite accidents.*
- b) **Do not operate power tools in explosive atmospheres, such as in the presence of flammable liquids, gases or dust.**  
*Power tools create sparks which may ignite the dust or fumes.*
- c) **Keep children and bystanders away while operating a power tool.**  
*Distractions can cause you to lose control.*

#### 2) Electrical safety

- a) **Power tool plugs must match the outlet. Never modify the plug in any way. Do not use any adapter plugs with earthed (grounded) power tools.**  
*Unmodified plugs and matching outlets will reduce risk of electric shock.*
- b) **Avoid body contact with earthed or grounded surfaces, such as pipes, radiators, ranges and refrigerators.**  
*There is an increased risk of electric shock if your body is earthed or grounded.*
- c) **Do not expose power tools to rain or wet conditions.**  
*Water entering a power tool will increase the risk of electric shock.*
- d) **Do not abuse the cord. Never use the cord for carrying, pulling or unplugging the power tool. Keep cord away from heat, oil, sharp edges or moving parts.**  
*Damaged or entangled cords increase the risk of electric shock.*
- e) **When operating a power tool outdoors, use an extension cord suitable for outdoor use.**  
*Use of a cord suitable for outdoor use reduces the risk of electric shock.*
- f) **If operating a power tool in a damp location is unavoidable, use a residual current device (RCD) protected supply.**  
*Use of an RCD reduces the risk of electric shock.*

#### 3) Personal safety

- a) **Stay alert, watch what you are doing and use common sense when operating a power tool. Do not use a power tool while you are tired or under the influence of drugs, alcohol or medication.**  
*A moment of inattention while operating power tools may result in serious personal injury.*
- b) **Use personal protective equipment. Always wear eye protection.**  
*Protective equipment such as a dust mask, non-skid safety shoes, hard hat or hearing protection used for appropriate conditions will reduce personal injuries.*

- c) **Prevent unintentional starting. Ensure the switch is in the off-position before connecting to power source and/or battery pack, picking up or carrying the tool.**

*Carrying power tools with your finger on the switch or energising power tools that have the switch on invites accidents.*

- d) **Remove any adjusting key or wrench before turning the power tool on.**

*A wrench or a key left attached to a rotating part of the power tool may result in personal injury.*

- e) **Do not overreach. Keep proper footing and balance at all times.**

*This enables better control of the power tool in unexpected situations.*

- f) **Dress properly. Do not wear loose clothing or jewellery. Keep your hair and clothing away from moving parts.**

*Loose clothes, jewellery or long hair can be caught in moving parts.*

- g) **If devices are provided for the connection of dust extraction and collection facilities, ensure these are connected and properly used.**

*Use of dust collection can reduce dust-related hazards.*

- h) **Do not let familiarity gained from frequent use of tools allow you to become complacent and ignore tool safety principles.**

*A careless action can cause severe injury within a fraction of a second.*

#### 4) Power tool use and care

- a) **Do not force the power tool. Use the correct power tool for your application.**  
*The correct power tool will do the job better and safer at the rate for which it was designed.*
- b) **Do not use the power tool if the switch does not turn it on and off.**  
*Any power tool that cannot be controlled with the switch is dangerous and must be repaired.*
- c) **Disconnect the plug from the power source and/or remove the battery pack, if detachable, from the power tool before making any adjustments, changing accessories, or storing power tools.**  
*Such preventive safety measures reduce the risk of starting the power tool accidentally.*
- d) **Store idle power tools out of the reach of children and do not allow persons unfamiliar with the power tool or these instructions to operate the power tool.**  
*Power tools are dangerous in the hands of untrained users.*
- e) **Maintain power tools and accessories. Check for misalignment or binding of moving parts, breakage of parts and any other condition that may affect the power tool's operation. If damaged, have the power tool repaired before use.**  
*Many accidents are caused by poorly maintained power tools.*
- f) **Keep cutting tools sharp and clean.**  
*Properly maintained cutting tools with sharp cutting edges are less likely to bind and are easier to control.*
- g) **Use the power tool, accessories and tool bits etc. in accordance with these instructions, taking into account the working conditions and the work to be performed.**  
*Use of the power tool for operations different from those intended could result in a hazardous situation.*

- h) **Keep handles and grasping surfaces dry, clean and free from oil and grease.**

*Slippery handles and grasping surfaces do not allow for safe handling and control of the tool in unexpected situations.*

**5) Battery tool use and care**

- a) **Recharge only with the charger specified by the manufacturer.**

*A charger that is suitable for one type of battery pack may create a risk of fire when used with another battery pack.*

- b) **Use power tools only with specifically designated battery packs.**

*Use of any other battery packs may create a risk of injury and fire.*

- c) **When battery pack is not in use, keep it away from other metal objects, like paper clips, coins, keys, nails, screws or other small metal objects, that can make a connection from one terminal to another.**

*Shorting the battery terminals together may cause burns or a fire.*

- d) **Under abusive conditions, liquid may be ejected from the battery; avoid contact. If contact accidentally occurs, flush with water. If liquid contacts eyes, additionally seek medical help.**

*Liquid ejected from the battery may cause irritation or burns.*

- e) **Do not use a battery pack or tool that is damaged or modified.**

*Damaged or modified batteries may exhibit unpredictable behaviour resulting in fire, explosion or risk of injury.*

- f) **Do not expose a battery pack or tool to fire or excessive temperature.**

*Exposure to fire or temperature above 130°C may cause explosion.*

- g) **Follow all charging instructions and do not charge the battery pack or tool outside the temperature range specified in the instructions.**

*Charging improperly or at temperatures outside the specified range may damage the battery and increase the risk of fire.*

**6) Service**

- a) **Have your power tool serviced by a qualified repair person using only identical replacement parts.**

*This will ensure that the safety of the power tool is maintained.*

- b) **Never service damaged battery packs.**

*Service of battery packs should only be performed by the manufacturer or authorized service providers.*

**PRECAUTION**

**Keep children and infirm persons away.**

**When not in use, tools should be stored out of reach of children and infirm persons.**

**CORDLESS ROTARY HAMMER SAFETY WARNINGS**

**Safety instructions for all operations**

- 1. Wear ear protectors**

*Exposure to noise can cause hearing loss.*

- 2. Use the auxiliary handle(s), if supplied with the tool.**

*Loss of control can cause personal injury.*

- 3. Hold the power tool by insulated gripping surfaces, when performing an operation where the cutting accessory may contact hidden wiring.**

*Cutting accessory contacting a "live" wire may make exposed metal parts of the power tool "live" and could give the operator an electric shock.*

**Safety instructions when using long drill bits with rotary hammers**

- 4. Always start drilling at low speed and with the bit tip in contact with the workpiece.**

*At higher speeds, the bit is likely to bend if allowed to rotate freely without contacting the workpiece, resulting in personal injury.*

- 5. Apply pressure only in direct line with the bit and do not apply excessive pressure.**

*Bits can bend causing breakage or loss of control, resulting in personal injury.*

**ADDITIONAL SAFETY WARNINGS**

1. Do not allow foreign matter to enter the hole for connecting the rechargeable battery.

2. Never disassemble the rechargeable battery and charger.

3. Never short-circuit the rechargeable battery. Shortcircuiting the battery will cause a great electric current and overheat. It results in burn or damage to the battery.

4. Do not dispose of the battery in fire. If the battery is burnt, it may explode.

5. When using this unit continuously, the unit may overheat, leading to damage in the motor and switch. Please leave it without using it for approximately 15 minutes.

6. Do not insert object into the air ventilation slots of the charger. Inserting metal objects or inflammables into the charger air ventilation slots will result in electrical shock hazard or damaged charger.

7. Bring the battery to the shop from which it was purchased as soon as the post-charging battery life becomes too short for practical use. Do not dispose of the exhausted battery.

8. Before starting to break, chip or drill into a wall, floor or ceiling, thoroughly confirm that such items as electric cables or conduits are not buried inside.

9. Ensure that the power switch is in the OFF position. If the battery is installed while the power switch is in the ON position, the power tool will start operating immediately, which could cause a serious accident.

10. Do not touch the bit during or immediately after operation. The bit becomes very hot during operation and could cause serious burns.

11. Always hold the body handle and side handle of the power tool firmly. Otherwise the counterforce produced may result in inaccurate and even dangerous operation.

12. Wear a dust mask

*Do not inhale the harmful dusts generated in drilling or chiseling operation. The dust can endanger the health of yourself and bystanders.*

13. Make sure that the battery is installed firmly. If it is all loose it could come off and cause an accident.

14. To prevent accidents, make sure to turn the switch off and pull out the battery before changing accessories, storing, carrying or when not using the tools.

15. Mounting the drill bit

- To prevent accidents, make sure to turn the switch off and pull out the battery.

- When using tools such as bull points, drill bits, etc., make sure to use the genuine parts designated by our company.

- Clean the shank portion of the drill bit.

- Check the latching by pulling on the drill bit.

16. Operate the change lever only when the motor is at a full stop. Operating the change lever while the motor is running may cause the tip tool to unexpectedly rotate and result in an accident. (Fig. 11)
17. Rotation + hammering  
DH1826DC: Using drill bit holder (standard accessories)  
When the drill bit touches construction iron bar, the bit will stop immediately and the rotary hammer will react to revolve. Therefore firmly tighten the side handle, hold the body handle and side handles.
18. Rotation only  
DH1826DC: Using drill chuck holder (standard accessories)
  - To drill wood or metal material using the drill chuck and chuck adapter (optional accessories).
  - Not using dust extractor system
  - Do not apply excessive force during operation. Doing so will not only damage the tip of the drill bit, but also reduce the service life of the rotary hammer.
  - A drill bit can snap off upon penetrating a drilled hole. When the drill is near penetration, lighten the pressure on the rotary hammer and continue drilling until penetration is achieved.
  - Do not attempt to drill anchor holes or holes in concrete with the machine set in the rotation only function.
  - Do not attempt to use the rotary hammer in the rotation and striking mode with the drill chuck and chuck adapter attached. This would seriously shorten the service life of every component of the machine.
19. Hammering only  
DH1826DC: Using drill bit holder (standard accessories)
  - Not using dust extractor system
20. Do not look directly into the light. Such actions could result in eye injury.  
Wipe off any dirt or grime attached to the lens of the LED light with a soft cloth, being careful not to scratch the lens.  
Scratches on the lens of the LED light can result in decreased brightness.
21. Make sure to securely hold the tool as shown in Fig. 22 during operation.

## CAUTION ON LITHIUM-ION BATTERY

To extend the lifetime, the lithium-ion battery equips with the protection function to stop the output.

In the cases of 1 to 3 described below, when using this product, even if you are pulling the switch, the motor may stop. This is not the trouble but the result of protection function.

1. When the battery power remaining runs out, the motor stops.  
In such a case, charge it up immediately.
2. If the tool is overloaded, the motor may stop. In this case, release the switch of tool and eliminate causes of overloading. After that, you can use it again.
3. If the battery is overheated under overload work, the battery power may stop.  
In this case, stop using the battery and let the battery cool. After that, you can use it again.

Furthermore, please heed the following warning and caution.

### WARNING

In order to prevent any battery leakage, heat generation, smoke emission, explosion and ignition beforehand, please be sure to heed the following precautions.

1. Make sure that swarf and dust do not collect on the battery.
  - During work make sure that swarf and dust do not fall on the battery.
  - Make sure that any swarf and dust falling on the power tool during work do not collect on the battery.
  - Do not store an unused battery in a location exposed to swarf and dust.
  - Before storing a battery, remove any swarf and dust that may adhere to it and do not store it together with metal parts (screws, nails, etc.).
2. Do not pierce battery with a sharp object such as a nail, strike with a hammer, step on, throw or subject the battery to severe physical shock.
3. Do not use an apparently damaged or deformed battery.
4. Do not use the battery in reverse polarity.
5. Do not connect directly to an electrical outlets or car cigarette lighter sockets.
6. Do not use the battery for a purpose other than those specified.
7. If the battery charging fails to complete even when a specified recharging time has elapsed, immediately stop further recharging.
8. Do not put or subject the battery to high temperatures or high pressure such as into a microwave oven, dryer, or high pressure container.
9. Keep away from fire immediately when leakage or foul odor are detected.
10. Do not use in a location where strong static electricity generates.
11. If there is battery leakage, foul odor, heat generated, discolored or deformed, or in any way appears abnormal during use, recharging or storage, immediately remove it from the equipment or battery charger, and stop use.
12. Do not immerse the battery or allow any fluids to flow inside. Conductive liquid ingress, such as water, can cause damage resulting in fire or explosion. Store your battery in a cool, dry place, away from combustible and flammable items. Corrosive gas atmospheres must be avoided.

### CAUTION

1. If liquid leaking from the battery gets into your eyes, do not rub your eyes and wash them well with fresh clean water such as tap water and contact a doctor immediately.  
If left untreated, the liquid may cause eye-problems.
2. If liquid leaks onto your skin or clothes, wash well with clean water such as tap water immediately.  
There is a possibility that this can cause skin irritation.
3. If you find rust, foul odor, overheating, discolor, deformation, and/or other irregularities when using the battery for the first time, do not use and return it to your supplier or vendor.

### WARNING

If a conductive foreign matter enters in the terminal of lithium ion battery, the battery may be shorted, causing fire. When storing the lithium ion battery, obey surely the rules of following contents.

- Do not place conductive debris, nail and wires such as iron wire and copper wire in the storage case.
- To prevent shorting from occurring, load the battery in the tool or insert securely the battery cover for storing until the ventilator is not seen.

## REGARDING LITHIUM-ION BATTERY TRANSPORTATION

When transporting a lithium-ion battery, please observe the following precautions.

### WARNING

Notify the transportation company that a package contains a lithium-ion battery, inform the company of its power output and follow the instructions of the transportation company when arranging transport.

- Lithium-ion batteries that exceed a power output of 100 Wh are considered to be in the freight classification of Dangerous Goods and will require special application procedures.
- For transportation abroad, you must comply with international law and the rules and regulations of the destination country.

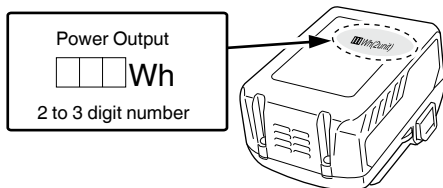

## NAMES OF PARTS (Fig. 1-Fig. 22)

① Handle	⑳ Nozzle adjustment button
② Switch trigger	㉑ Dust housing
③ Pushing button	㉒ Dust box
④ Housing	㉓ Dust box latch (both side)
⑤ Side handle	㉔ Filter
⑥ Depth gauge	㉕ Button
⑦ Drill bit	㉖ Latch
⑧ Front cap	㉗ Charge indicator lamp
⑨ Grip	㉘ Indicator lamp
⑩ Name plate	㉙ Grease
⑪ Change lever	㉚ Pushing button (Change lever)
⑫ Gear cover	㉛ Cold chisel
⑬ Motor	㉜ Bit holder ass'y
⑭ LED light	㉝ Chuck holder ass'y
⑮ Battery	㉞ Auto stop lamp: Blinks
⑯ Display panel	㉟ Auto stop lamp: Lights
⑰ Changeover switch	㊱ Battery sliding grooves
⑱ Display lamp	㊲ Terminal (Product)
㉑ Auto stop lamp	㊳ Air gun
㉒ Nozzle	㊴ Terminal (Battery)
㉓ Depth adjustment button	㊵ Sliding grooves

## SYMBOLS







### WARNING

The following show symbols used for the machine. Be sure that you understand their meaning before use.

	DH1826DA / DH1826DC: Cordless Rotary Hammer
	To reduce the risk of injury, user must read instruction manual.
V	Rated voltage
n <sub>0</sub>	No-load speed
Bpm	Full-load impact rate
φ max	Drilling diameter, max.
	Weight*
	Concrete
	Steel
	Wood
	Hammering only function
	Rotation only function
	Rotation and hammering function
	Disconnect the battery
	Switching ON
	Switching OFF
	Low mode
	Normal mode
	Clockwise rotation
	Counterclockwise rotation

\* Depending on attached battery. The heaviest weight is measured with BSL36B18 (sold separately).

## Battery

	Lights ; The battery remaining power is over 75%.
	Lights ; The battery remaining power is 50%–75%.
	Lights ; The battery remaining power is 25%–50%.
	Lights ; The battery remaining power is less than 25%.
	Blinks ; The battery remaining power is nearly empty. Recharge the battery soonest possible.
	Blinks ; Output suspended due to high temperature. Remove the battery from the tool and allow it to fully cool down.
	Blinks ; Output suspended due to failure or malfunction. The problem may be the battery so please contact your dealer.

## SPECIFICATIONS

The specifications of this machine are listed in the Table on page 16.

\*1 Specifications are for when a dust extractor system has been installed.

### NOTE

- Existing batteries (BSL3660/3626X/3626/3625/3620 and BSL14xx series) cannot be used with this tool.
- Due to HiKOKI's continuing program of research and development, the specifications herein are subject to change without prior notice.

## CHARGING

Before using the power tool, charge the battery as follows.

1. **Connect the charger's power cord to the receptacle.**  
When connecting the plug of the charger to a receptacle, the pilot lamp will blink in red (At 1- second intervals).
  2. **Insert the battery into the charger.**  
Firmly insert the battery into the charger as shown in Fig. 4 (on page 3).
  3. **Charging**  
When inserting a battery in the charger, charging will commence and the pilot lamp will light continuously in red.  
When the battery becomes fully recharged, the pilot lamp will blink in red. (At 1-second intervals) (See Table 1)
- Pilot lamp indication  
The indications of the pilot lamp will be as shown in Table 1, according to the condition of the charger or the rechargeable battery.

## STANDARD ACCESSORIES

In addition to the main unit (1 unit), the package contains the accessories listed on page 16.

Standard accessories are subject to change without notice.

## APPLICATIONS

Rotation and hammering function 

- Drilling anchor holes
- Drilling holes in concrete
- Drilling holes in tile



Rotation only function  (without dust extractor system)

- Drilling in steel or wood (with optional accessories)
- Tightening machine screws, wood screws (with optional accessories)

Hammering only function  (without dust extractor system)

- Light-duty chiselling of concrete, groove digging and edging.

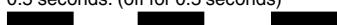
Table 1

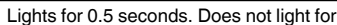
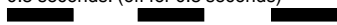
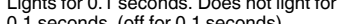
		Indications of the pilot lamp		
Pilot lamp (red)	Before charging	Blinks	Lights for 0.5 seconds. Does not light for 0.5 seconds. (off for 0.5 seconds) 	
	While charging	Lights	Lights continuously 	
	Charging complete	Blinks	Lights for 0.5 seconds. Does not light for 0.5 seconds. (off for 0.5 seconds) 	
	Charging impossible	Flickers	Lights for 0.1 seconds. Does not light for 0.1 seconds. (off for 0.1 seconds) 	Malfunction in the battery or the charger
	Overheat standby	Blinks	Lights for 1 second. Does not light for 0.5 seconds. (off for 0.5 seconds) 	Battery overheated. Unable to charge. (Charging will commence when battery cools)

- Regarding the temperatures and charging time of the battery.  
The temperatures and charging time will become as shown in **Table 2**.

**Table 2**

Charger		UC18YFSL					
Battery	Type of battery	Li-ion					
	Temperatures at which the battery can be recharged	0°C–50°C					
	Charging voltage	V	14.4		18		
	Charging time, approx. (At 20°C)	min	BSL14xx series		BSL18xx series		Multi volt series
			(4 cells)	(8 cells)	(5 cells)	(10 cells)	(10 cells)
			BSL1415S : 20 BSL1415 : 22 BSL1415X : 22 BSL1420 : 30 BSL1425 : 35 BSL1430C : 45	BSL1430 : 45 BSL1440 : 60 BSL1450 : 75 BSL1460 : 90	BSL1815S : 20 BSL1815 : 22 BSL1815X : 22 BSL1820 : 30 BSL1825 : 35 BSL1830C : 45 BSL1850C : 75	BSL1830 : 45 BSL1840 : 60 BSL1850 : 75 BSL1850MA : 75 BSL1860 : 90	BSL36A18 : 75 BSL36B18 : 120

**NOTE**

The recharging time may vary according to the ambient temperature and power source voltage.

**CAUTION**

When the battery charger has been continuously used, the battery charger will be heated, thus constituting the cause of the failures. Once the charging has been completed, give 15 minutes rest until the next charging.

**4. Disconnect the charger's power cord from the receptacle.**

**5. Hold the charger firmly and pull out the battery.**

**NOTE**

Be sure to pull out the battery from the charger after use, and then keep it.

- When the pilot lamp flickers in red (at 0.2-seconds intervals), check for and take out any foreign objects in the charger's battery connector. If there are no foreign objects, it is probable that the battery or charger is malfunctioning. Take it to your authorized Service Center.
- Since the built-in micro computer takes about 3 seconds to confirm that the battery being charged with chargers are taken out, wait for a minimum of 3 seconds before reinserting it to continue charging. If the battery is reinserted within 3 seconds, the battery may not be properly charged.

**MOUNTING AND OPERATION**

**Regarding electric discharge in case of new batteries, etc.**

As the internal chemical substance of new batteries and batteries that have not been used for an extended period is not activated, the electric discharge might be low when using them the first and second time. This is a temporary phenomenon, and normal time required for recharging will be restored by recharging the batteries 2–3 times.

**How to make the batteries perform longer.**

- (1) Recharge the batteries before they become completely exhausted.

When you feel that the power of the tool becomes weaker, stop using the tool and recharge its battery. If you continue to use the tool and exhaust the electric current, the battery may be damaged and its life will become shorter.

- (2) Avoid recharging at high temperatures.

A rechargeable battery will be hot immediately after use. If such a battery is recharged immediately after use, its internal chemical substance will deteriorate, and the battery life will be shortened. Leave the battery and recharge it after it has cooled for a while.

**CAUTION**

- If the battery is charged while it is heated because it has been left for a long time in a location subject to direct sunlight or because the battery has just been used, the pilot lamp of the charger lights up green or lights for 1 second, does not light for 0.5 seconds (off for 0.5 seconds). In such a case, first let the battery cool, then start charging.

Action	Figure	Page
Names of parts - Cordless rotary hammer	1	2
Names of parts - Dust extractor system for Rotary hammer*1	2	2
Removing and inserting the battery	3	3
Charging	4	3
Remaining battery indicator	5	3
Indicator lamp lights when battery is low	6	3
Installing / Removing the side handle	7	3
Inserting SDS-plus drilling tools	8	4
Removing SDS-plus drilling tools	9	4
Selecting rotation direction	10	4
Selecting the operating mode	11	4
Adjusting the drilling depth	12	4
Changing the chisel position	13	4
Removing the quick release chuck (DH1826DC)*2	14	5
Inserting the quick release chuck (DH1826DC)	15	5

Inserting round shank applications tools (DH1826DC)	16	5
Switch operation	17	5
Setting the speed	18	5
Auto stop function	19	5
How to use the LED light	20	6
Cleaning of the battery installation compartment	21	6
Installing the side handle	22	6
Selecting accessories*3	—	17, 18

- \*1 For details on how to use the Dust extractor system, refer to the system's instruction manual.
- \*2 If it is hard to pull out the drill chuck holder or the drill bit holder, align the change lever with the **T** mark and turn the lock grip.
- \*3 For detailed information regarding each tool, contact a HiKOKI authorized service center.

## SELECT OPERATION MODE

Pressing the changeover switch allows the selection of rotation speed and the auto stop function.

- Rotation speed (Low mode/Normal mode) (**Fig. 18**)  
Select either Low mode or Normal mode and operate the tool in the selected speed.
- Auto stop mode (on/off) (**Fig. 19**)  
This product is equipped with an auto stop function to support continuous drilling work. The function features a memory mode for storing the work time for drilling from switch ON to switch OFF, and an auto stop mode that automatically stops the motor from the second drilling onward should the work exceed the stored work time while the switch is ON.

## AUTO STOP FUNCTION

In selection mode, pressing the button for longer than two seconds will move to memory mode. (**Fig. 19**)  
(At the same time the auto stop lamp will blink.)

Conduct drilling when the auto stop lamp is flashing. The time between switching ON and switching OFF is stored by the tool.

(At the same time, the auto stop lamp will light up.)

Conduct drilling when the auto stop lamp is flashing. Continuous drilling is possible as the memory storage time will be recorded by the tool until the auto stop function's auto stop mode is cancelled.

The auto stop function is cancelled by pressing the changeover switch once again for over two seconds.

(At the same time, the auto stop lamp will switch off.)

### CAUTION

- Switch ON the tool once you place the tip of the tool on the work material.
- The rotation speed and the level at which the switch is pulled during drilling is not stored to memory.
- Fully carry out drilling in one go during auto stop mode.
- The motor will stop even if you switch OFF within the memory storage time.
- When you switch OFF within the memory storage time, the count will be reset. If you rework a task in which a hole has been partially drilled, the memory storage time will be fully recounted.
- The auto stop function will remain active until canceled.

## REACTIVE FORCE CONTROL

This product is equipped with a Reactive Force Control (RFC) feature that reduces jerking of the tool body.

If the tool bit is suddenly overburdened, any jerking of the tool body is reduced by activation of the slip clutch or by stopping of the motor by the sensor built into the tool body.

If the motor is stopped because of overburdening detection by the controller, the display lamp will blink while the switch is pulled. In addition, the lamp will continue blinking for approximately three seconds after the switch is released. The motor will remain stopped while the lamp is blinking. (**Fig. 23**)

Because the RFC feature may not activate or its performance may be insufficient depending on the working environment and conditions, be careful not to suddenly overburden the tool bit while operating.

- Possible causes of sudden overburdening
  - ① Tool bit biting into material
  - ② Impact against nails, metal or other hard objects
  - ③ Tasks involving prying or any excess application of pressure, etc.

Also, other causes include any combination of the aforementioned.

- When the reactive force control (RFC) is triggered  
When the RFC is triggered and the motor stops, turn off the tool's switch and remove the cause of the overburdening before continuing operation.

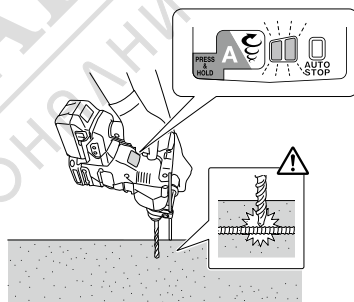

**Fig. 23**

## ABOUT THE PROTECTION FUNCTION

This tool has a built-in protection circuit for preventing damage to the unit in the event of an abnormality. Depending on the following, the display lamp will flash, and the unit will cease to operate. Verify the problem indicated by the flashing and take the necessary steps to correct the problem.

When pressing the changeover switch, do so when the switch is not being pulled.

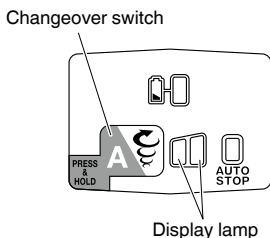

Fig. 24

Table 3

Display lamp flashing	Cause	Solution
	Operation has ceased because the internal temperature has exceeded the temperature limit. (High temperature protection function)	Allow the unit to cool for 15 to 30 minutes. When the temperature goes down and the display lamp blinking stops, pull the switch trigger to recover operation.
	Sudden overburdening of the tool bit has activated the RFC, stopping further operation of the tool. RFC (See page 13 "REACTIVE FORCE CONTROL")	Release the switch trigger and leave it until the display lamp blinking stops. Pull the switch trigger again to recover operation. Before continuing operation, remove the cause of the overburden.

### NOTE

Despite taking steps to correct a problem, the display lamp may continue to blink. Should this be the case, the unit may require repair. If so, please contact the outlet from which this product was purchased for repairs.

## LUBRICATION

This Rotary Hammer is of full air-tight construction to protect against dust.

Therefore, this Rotary Hammer can be used without lubrication for long periods.

After purchase, periodically replace grease. Ask for grease replacement at the nearest authorized Service Center.

### CAUTION

A specific grease is used with this machine, therefore, the normal performance of the machine may be badly affected by use of different grease. Please be sure to let one of our service centers to undertake replacement of the grease.

## MAINTENANCE AND INSPECTION

### WARNING

Be sure to turned off the switch and remove the battery before maintenance and inspection.

#### 1. Inspecting the tool

Since use of as dull tool will degrade efficiency and cause possible motor malfunction, sharpen or replace the tool as soon as abrasion is noted.

#### 2. Inspecting the mounting screws

Regularly inspect all mounting screws and ensure that they are properly tightened. Should any of the screws be loose, retighten them immediately. Failure to do so could result in serious hazard.

#### 3. Maintenance of the motor

The motor unit winding is the very "heart" of the power tool. Exercise due care to ensure the winding does not become damaged and/or wet with oil or water.

#### 4. Inspection of terminals (tool and battery)

Check to make sure that swarf and dust have not collected on the terminals.

On occasion check prior, during and after operation.

### CAUTION

Remove any swarf or dust which may have collected on the terminals.

Failure to do so may result in malfunction.

#### 5. Cleaning on the outside

When the power tool is stained, wipe with a soft dry cloth or a cloth moistened with soapy water. Do not use chloric solvents, gasoline or paint thinner, for they melt plastics.

#### 6. Cleaning the battery installation compartment and the battery

After drilling concrete, if concrete dust has accumulated on the battery installation compartment and the battery, clean off the accumulated concrete dust with an air gun or a dry cloth before using the tool. (Fig. 21)

Also, after cleaning, ensure that the battery can be installed and removed smoothly from the tool.

### CAUTION

Using the tool when the battery is covered with concrete dust may lead to accidents such as the battery falling during use.

Furthermore, such use may cause a malfunction or contact failure between the battery and the terminals.

#### 7. Storage

Store the power tool and battery in a place in which the temperature is less than 40°C and out of reach of children.

### NOTE

Storing lithium-ion batteries.

Make sure the lithium-ion batteries have been fully charged before storing them.

Prolonged storage (3 months or more) of batteries with a low charge may result in performance deterioration, significantly reducing battery usage time or rendering the batteries incapable of holding a charge.

However, significantly reduced battery usage time may be recovered by repeatedly charging and using the batteries two to five times.

If the battery usage time is extremely short despite repeated charging and use, consider the batteries dead and purchase new batteries.

### CAUTION

In the operation and maintenance of power tools, the safety regulations and standards prescribed in each country must be observed.

**Important notice on the batteries for the HiKOKI cordless power tools**

Please always use one of our designated genuine batteries. We cannot guarantee the safety and performance of our cordless power tool when used with batteries other than these designated by us, or when the battery is disassembled and modified (such as disassembly and replacement of cells or other internal parts).

**NOTE**





Due to HiKOKI's continuing program of research and development, the specifications herein are subject to change without prior notice.







**TROUBLESHOOTING**





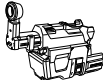

Use the inspections in the table below if the tool does not operate normally. If this does not remedy the problem, consult your dealer or the HiKOKI Authorized Service Center.

Symptom	Possible cause	Remedy
Tool doesn't run	No remaining battery power	Charge the battery.
	Battery isn't securely attached.	Push in the battery until a click is heard.
	Concrete dust has accumulated on the terminals of the battery installation compartment as well as on the battery sliding grooves.	Clean off the accumulated concrete dust with an air gun or a dry cloth.
Tool suddenly stopped	Tool was overburdened	Get rid of the problem causing the overburden.
	Reactive force control was activated	
	The battery is overheated.	Let the battery cool down.
Tool bits -can't be attached -fall off	The shape of the attachment portion doesn't match	For the SDS-plus shank type, use a bit with a diameter that is within the designated range.
Holes can't be smoothly drilled.	The drill is worn	Replace with a new drill.
	The drill is rotating in reverse	Switch to forward rotation.
Screw head slips or comes loose.	Bit number doesn't match with the screw size	Install a suitable bit.
	The bit is worn	Replace with a new bit.
Battery cannot be installed	Attempting to install a battery other than that specified for the tool.	Please install batteries that are multi volt or BSL18xx series.



	DH1826DA	DH1826DC	DH1826DA*1	DH1826DC*1
V	18 V			
$n_0$	0-950 /min			
Bpm	0-4300 /min			
$\phi$ max 	26 mm		20 mm	
$\phi$ max 	13 mm		-	
$\phi$ max 	27 mm		-	
	3.5-4.1 kg	3.7-4.3 kg	4.5-5.1 kg	4.7-5.3 kg

							
DH1826DA	2JAS	1	1	1	1	2	1
	2JA	1	1	-	-	2	1
	NNPS	1	1	1	1	-	-
	NNP	1	1	-	-	-	-
	NN	1	1	-	-	-	-
DH1826DC	2JAS	1	1	1	1	2	1
	2JA	1	1	-	-	2	1
	NNPS	1	1	1	1	-	-
	NNP	1	1	-	-	-	-
	NN	1	1	-	-	-	-

								
DH1826DA	2JAS	1	1	1	1	1	-	-
	2JA	1	1	-	1	1	-	-
	NNPS	-	-	2	1	-	-	-
	NNP	-	-	1	1	-	-	-
	NN	-	-	-	-	-	-	-
DH1826DC	2JAS	1	1	1	1	1	1	1
	2JA	1	1	-	1	1	1	1
	NNPS	-	-	2	1	-	1	1
	NNP	-	-	1	1	-	1	1
	NN	-	-	-	-	-	1	1

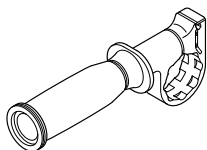

335273

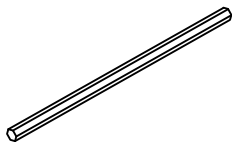

303709

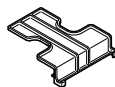

329897

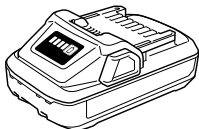

BSL18..

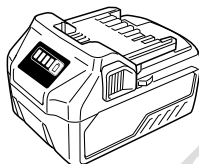
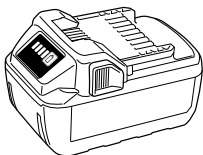

BSL36..18

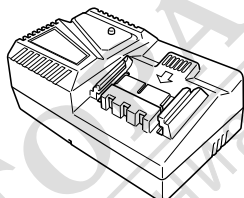

UC18YFSL  
(14.4V-18V)

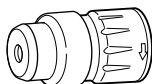

375010



377959

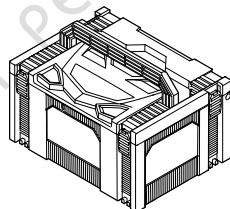

337108

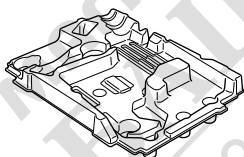

379786

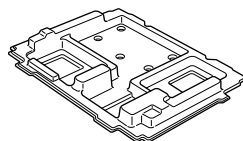

379787

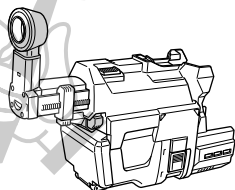

379135 (DH1826DA)  
379139 (DH1826DC)

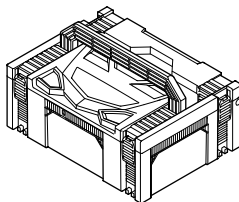

336471

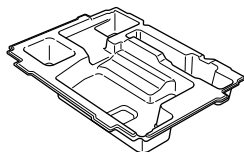

379788

379136(DH1826DA)  
379140(DH1826DC)

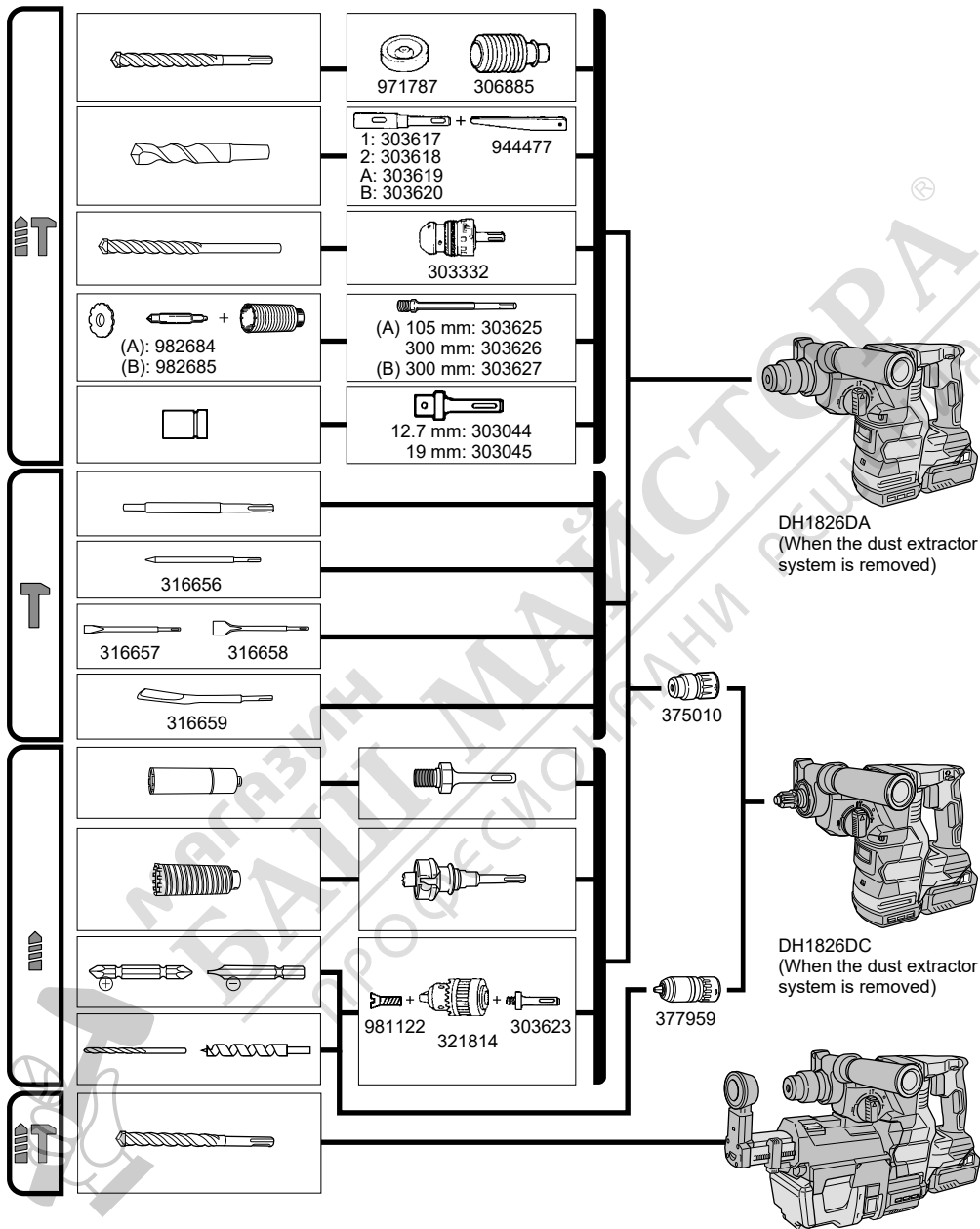

DH1826DA  
(When the dust extractor system is removed)

DH1826C  
(When the dust extractor system is removed)

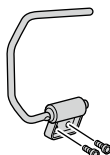

379770



МАГАЗИН  
**БАШ МАЙСТОРА**<sup>®</sup>  
ПРОФЕСИОНАЛНИ РЕШЕНИЯ



МАГАЗИН  
БАШ МАЙСТОРА®  
ПРОФЕСИОНАЛНИ РЕШЕНИЯ

## Koki Holdings Co., Ltd.

Shinagawa Intercity Tower A, 15-1, Konan 2-chome,  
Minato-ku, Tokyo, Japan