

INSTRUCTION MANUAL

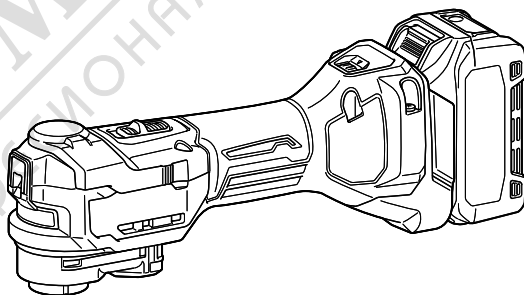

Cordless Multi Tool

TM001G



Read before use.

МАГАЗИН
БАШ
ПРОФЕССИОНАЛЬНЫЕ РЕШЕНИЯ
МАЙСТОРА



SPECIFICATIONS

Model:	TM001G	
Oscillation per minute	10,000 - 20,000 min ⁻¹	
Oscillation angle, left/right	1.8° (3.6° total)	
Overall length	with BL4025	326 mm
Net weight	2.1 - 3.3 kg	
Rated voltage	D.C. 36 V - 40 V max	

- Due to our continuing program of research and development, the specifications herein are subject to change without notice.
- Specifications may differ from country to country.
- The weight may differ depending on the attachment(s), including the battery cartridge. The lightest and heaviest combinations, according to EPTA-Procedure 01/2014, are shown in the table.

Applicable battery cartridge and charger









Battery cartridge	BL4020* / BL4025* / BL4040* / BL4040F* / BL4050F / BL4080F * : Recommended battery
Charger	DC40RA / DC40RB / DC40RC / DC40WA

- Some of the battery cartridges and chargers listed above may not be available depending on your region of residence.

⚠ WARNING: Only use the battery cartridges and chargers listed above. Use of any other battery cartridges and chargers may cause injury and/or fire.



Applicable application tool

Use the application tool which type is adaptable to this tool as shown in the following table.

	OIS	
	STARLOCK	
	STARLOCK PLUS	
	STARLOCK MAX	

Symbols

The followings show the symbols which may be used for the equipment. Be sure that you understand their meaning before use.

	Read instruction manual.
	Wear eye protection.



Only for EU countries

Due to the presence of hazardous components in the equipment, waste electrical and electronic equipment, accumulators and batteries may have a negative impact on the environment and human health. Do not dispose of electrical and electronic appliances or batteries with household waste!

In accordance with the European Directive on waste electrical and electronic equipment and on accumulators and batteries and waste accumulators and batteries, as well as their adaptation to national law, waste electrical equipment, batteries and accumulators should be stored separately and delivered to a separate collection point for municipal waste, operating in accordance with the regulations on environmental protection.

This is indicated by the symbol of the crossed-out wheeled bin placed on the equipment.

Intended use

The tool is intended for sawing and cutting wood, plastic, gypsum, non-ferrous metals, and fastening elements (e.g. nails and staples). It is also intended for working soft wall tiles, as well as dry sanding and scraping of small surfaces. It is especially for working close to edge and flush cutting.

Noise

The following table shows the typical A-weighted noise level determined according to applicable standard.

Work mode	Sound pressure level (L _{PA})	Uncertainty (K)	Applicable standard
Sanding	72 dB (A)	3 dB (A)	EN62841-2-4
Cutting with plunge cut saw blade	75 dB(A)	3 dB(A)	EN62841-1
Cutting with segmental saw blade	79 dB(A)	3 dB(A)	EN62841-1
Scraping	74 dB(A)	3 dB(A)	EN62841-1

The noise level under working may exceed 80 dB (A).

NOTE: The declared noise emission value(s) has been measured in accordance with a standard test method and may be used for comparing one tool with another.

NOTE: The declared noise emission value(s) may also be used in a preliminary assessment of exposure.

⚠ WARNING: Wear ear protection.

⚠ WARNING: The noise emission during actual use of the power tool can differ from the declared value(s) depending on the ways in which the tool is used especially what kind of workpiece is processed.

⚠ WARNING: Be sure to identify safety measures to protect the operator that are based on an estimation of exposure in the actual conditions of use (taking account of all parts of the operating cycle such as the times when the tool is switched off and when it is running idle in addition to the trigger time).

Vibration

The following table shows the vibration total value (tri-axial vector sum) determined according to applicable standard.

Work mode	Vibration emission (a _h)	Uncertainty (K)	Applicable standard
Sanding	2.5 m/s ² or less	1.5 m/s ²	EN62841-2-4
Cutting with plunge cut saw blade	2.5 m/s ² or less	1.5 m/s ²	EN62841-1
Cutting with segmental saw blade	2.5 m/s ² or less	1.5 m/s ²	EN62841-1
Scraping	2.5 m/s ² or less	1.5 m/s ²	EN62841-1

NOTE: The declared vibration total value(s) has been measured in accordance with a standard test method and may be used for comparing one tool with another.

NOTE: The declared vibration total value(s) may also be used in a preliminary assessment of exposure.

⚠ WARNING: The vibration emission during actual use of the power tool can differ from the declared value(s) depending on the ways in which the tool is used especially what kind of workpiece is processed.

⚠ WARNING: Be sure to identify safety measures to protect the operator that are based on an estimation of exposure in the actual conditions of use (taking account of all parts of the operating cycle such as the times when the tool is switched off and when it is running idle in addition to the trigger time).

Declarations of Conformity

For European countries only

The Declarations of conformity are included in Annex A to this instruction manual.

SAFETY WARNINGS

General power tool safety warnings

⚠ WARNING Read all safety warnings, instructions, illustrations and specifications provided with this power tool. Failure to follow all instructions listed below may result in electric shock, fire and/or serious injury.

Save all warnings and instructions for future reference.

The term "power tool" in the warnings refers to your mains-operated (corded) power tool or battery-operated (cordless) power tool.

Work area safety

1. **Keep work area clean and well lit.** Cluttered or dark areas invite accidents.
2. **Do not operate power tools in explosive atmospheres, such as in the presence of flammable liquids, gases or dust.** Power tools create sparks which may ignite the dust or fumes.
3. **Keep children and bystanders away while operating a power tool.** Distractions can cause you to lose control.

Electrical safety

1. **Power tool plugs must match the outlet. Never modify the plug in any way. Do not use any adapter plugs with earthed (grounded) power tools.** Unmodified plugs and matching outlets will reduce risk of electric shock.
2. **Avoid body contact with earthed or grounded surfaces, such as pipes, radiators, ranges and refrigerators.** There is an increased risk of electric shock if your body is earthed or grounded.
3. **Do not expose power tools to rain or wet conditions.** Water entering a power tool will increase the risk of electric shock.
4. **Do not abuse the cord. Never use the cord for carrying, pulling or unplugging the power tool. Keep cord away from heat, oil, sharp edges**

or moving parts. Damaged or entangled cords increase the risk of electric shock.

5. **When operating a power tool outdoors, use an extension cord suitable for outdoor use.** Use of a cord suitable for outdoor use reduces the risk of electric shock.
6. **If operating a power tool in a damp location is unavoidable, use a residual current device (RCD) protected supply.** Use of an RCD reduces the risk of electric shock.
7. **Power tools can produce electromagnetic fields (EMF) that are not harmful to the user.** However, users of pacemakers and other similar medical devices should contact the maker of their device and/or doctor for advice before operating this power tool.

Personal safety

1. **Stay alert, watch what you are doing and use common sense when operating a power tool. Do not use a power tool while you are tired or under the influence of drugs, alcohol or medication.** A moment of inattention while operating power tools may result in serious personal injury.
2. **Use personal protective equipment. Always wear eye protection.** Protective equipment such as a dust mask, non-skid safety shoes, hard hat or hearing protection used for appropriate conditions will reduce personal injuries.
3. **Prevent unintentional starting. Ensure the switch is in the off-position before connecting to power source and/or battery pack, picking up or carrying the tool.** Carrying power tools with your finger on the switch or energising power tools that have the switch on invites accidents.
4. **Remove any adjusting key or wrench before turning the power tool on.** A wrench or a key left attached to a rotating part of the power tool may result in personal injury.
5. **Do not overreach. Keep proper footing and balance at all times.** This enables better control of the power tool in unexpected situations.
6. **Dress properly. Do not wear loose clothing or jewellery. Keep your hair and clothing away from moving parts.** Loose clothes, jewellery or long hair can be caught in moving parts.
7. **If devices are provided for the connection of dust extraction and collection facilities, ensure these are connected and properly used.** Use of dust collection can reduce dust-related hazards.
8. **Do not let familiarity gained from frequent use of tools allow you to become complacent and ignore tool safety principles.** A careless action can cause severe injury within a fraction of a second.
9. **Always wear protective goggles to protect your eyes from injury when using power tools. The goggles must comply with ANSI Z87.1 in the USA, EN 166 in Europe, or AS/NZS 1336 in Australia/New Zealand. In Australia/New Zealand, it is legally required to wear a face shield to protect your face, too.**

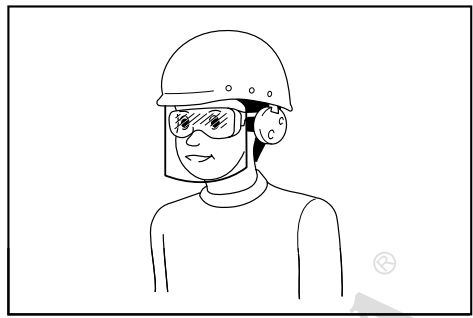

It is an employer's responsibility to enforce the use of appropriate safety protective equipments by the tool operators and by other persons in the immediate working area.

Power tool use and care

1. **Do not force the power tool. Use the correct power tool for your application.** The correct power tool will do the job better and safer at the rate for which it was designed.
2. **Do not use the power tool if the switch does not turn it on and off.** Any power tool that cannot be controlled with the switch is dangerous and must be repaired.
3. **Disconnect the plug from the power source and/or remove the battery pack, if detachable, from the power tool before making any adjustments, changing accessories, or storing power tools.** Such preventive safety measures reduce the risk of starting the power tool accidentally.
4. **Store idle power tools out of the reach of children and do not allow persons unfamiliar with the power tool or these instructions to operate the power tool.** Power tools are dangerous in the hands of untrained users.
5. **Maintain power tools and accessories. Check for misalignment or binding of moving parts, breakage of parts and any other condition that may affect the power tool's operation. If damaged, have the power tool repaired before use.** Many accidents are caused by poorly maintained power tools.
6. **Keep cutting tools sharp and clean.** Properly maintained cutting tools with sharp cutting edges are less likely to bind and are easier to control.
7. **Use the power tool, accessories and tool bits etc. in accordance with these instructions, taking into account the working conditions and the work to be performed.** Use of the power tool for operations different from those intended could result in a hazardous situation.
8. **Keep handles and grasping surfaces dry, clean and free from oil and grease.** Slippery handles and grasping surfaces do not allow for safe handling and control of the tool in unexpected situations.
9. **When using the tool, do not wear cloth work gloves which may be entangled.** The entanglement of cloth work gloves in the moving parts may result in personal injury.

Battery tool use and care

1. **Recharge only with the charger specified by the manufacturer.** A charger that is suitable for one type of battery pack may create a risk of fire when used with another battery pack.
2. **Use power tools only with specifically designed battery packs.** Use of any other battery packs may create a risk of injury and fire.
3. **When battery pack is not in use, keep it away from other metal objects, like paper clips, coins, keys, nails, screws or other small metal objects, that can make a connection from one terminal to another.** Shorting the battery terminals together may cause burns or a fire.
4. **Under abusive conditions, liquid may be ejected from the battery; avoid contact. If contact accidentally occurs, flush with water. If liquid contacts eyes, additionally seek medical help.** Liquid ejected from the battery may cause irritation or burns.
5. **Do not use a battery pack or tool that is damaged or modified.** Damaged or modified batteries may exhibit unpredictable behaviour resulting in fire, explosion or risk of injury.
6. **Do not expose a battery pack or tool to fire or excessive temperature.** Exposure to fire or temperature above 130 °C may cause explosion.
7. **Follow all charging instructions and do not charge the battery pack or tool outside the temperature range specified in the instructions.** Charging improperly or at temperatures outside the specified range may damage the battery and increase the risk of fire.

Service

1. **Have your power tool serviced by a qualified repair person using only identical replacement parts.** This will ensure that the safety of the power tool is maintained.
2. **Never service damaged battery packs.** Service of battery packs should only be performed by the manufacturer or authorized service providers.
3. **Follow instruction for lubricating and changing accessories.**

Cordless multi tool safety warnings

1. **This power tool is intended to function for sawing, cutting, scraping and sanding. Read all safety warnings, instructions, illustrations and specifications provided with this power tool.** Failure to follow all instructions listed below may result in electric shock, fire and/or serious injury.
2. **Hold the power tool by insulated gripping surfaces, when performing an operation where the cutting accessory may contact hidden wiring.** Cutting accessory contacting a "live" wire may make exposed metal parts of the power tool "live" and could give the operator an electric shock.
3. **Use clamps or another practical way to secure and support the workpiece to a stable platform.** Holding the work by hand or against your body leaves it unstable and may lead to loss of control.

4. **Always use safety glasses or goggles.** Ordinary eye or sun glasses are NOT safety glasses.
5. **Hold the tool firmly.**
6. **Make sure the application tool is not contacting the workpiece before the switch is turned on.**
7. **Keep hands away from moving parts.**
8. **Do not leave the tool running. Operate the tool only when hand-held.**
9. **Always switch off and wait for the blade to come to a complete stop before removing the blade from the workpiece.**
10. **Do not touch the application tool or the workpiece immediately after operation; they may be extremely hot and could burn your skin.**
11. **Do not operate the tool at no-load unnecessarily.**
12. **Always use the correct dust mask/respirator for the material and application you are working with.**
13. **Some material contains chemicals which may be toxic. Take caution to prevent dust inhalation and skin contact. Follow material supplier safety data.**
14. **This tool has not been waterproofed, so do not use water on the workpiece surface.**
15. **Ventilate your work area adequately when you perform sanding operations.**
16. **Use of this tool to sand some products, paints and wood could expose user to dust containing hazardous substances. Use appropriate respiratory protection.**
17. **Be sure that there are no cracks or breakage on the pad before use. Cracks or breakage may cause a personal injury.**
18. **Do not use accessories which are not specifically designed and recommended by the tool manufacturer. Just because the accessory can be attached to your power tool, it does not assure safe operation.**
19. **Wear personal protective equipment. Depending on application, use face shield, safety goggles or safety glasses. As appropriate, wear hearing protectors, gloves and workshop apron capable of stopping small abrasive or workpiece fragments.** The eye protection must be capable of stopping flying debris generated by various operations. The dust mask or respirator must be capable of filtering particles generated by your operation. Prolonged exposure to high intensity noise may cause hearing loss.
20. **Keep bystanders a safe distance away from work area. Anyone entering the work area must wear personal protective equipment.** Fragments of workpiece or of a broken accessory may fly away and cause injury beyond immediate area of operation.
21. **Never lay the power tool down until the accessory has come to a complete stop.** The spinning accessory may grab the surface and pull the power tool out of your control.
22. **Do not run the power tool while carrying it at your side.** Accidental contact with the accessory

- could snag your clothing, pulling the accessory into your body.
23. **Do not operate the power tool near flammable materials.** Sparks could ignite these materials.
 24. **Do not use accessories that require liquid coolants.** Using water or other liquid coolants may result in electrocution or shock.
 25. **Always be sure that the tool is switched off and unplugged or that the battery cartridge is removed before carrying out any work on the tool.**
 26. **Always be sure you have a firm footing. Be sure no one is below when using the tool in high locations.**
 27. **Before operation, make sure that there is no buried object such as electric pipe, water pipe or gas pipe in the workpiece.** Otherwise, it may cause an electric shock, electrical leakage or gas leak.

SAVE THESE INSTRUCTIONS.

⚠WARNING: DO NOT let comfort or familiarity with product (gained from repeated use) replace strict adherence to safety rules for the subject product. MISUSE or failure to follow the safety rules stated in this instruction manual may cause serious personal injury.

Important safety instructions for battery cartridge

1. Before using battery cartridge, read all instructions and cautionary markings on (1) battery charger, (2) battery, and (3) product using battery.
2. Do not disassemble or tamper with the battery cartridge. It may result in a fire, excessive heat, or explosion.
3. If operating time has become excessively shorter, stop operating immediately. It may result in a risk of overheating, possible burns and even an explosion.
4. If electrolyte gets into your eyes, rinse them out with clear water and seek medical attention right away. It may result in loss of your eyesight.
5. Do not short the battery cartridge:
 - (1) Do not touch the terminals with any conductive material.
 - (2) Avoid storing battery cartridge in a container with other metal objects such as nails, coins, etc.
 - (3) Do not expose battery cartridge to water or rain.

A battery short can cause a large current flow, overheating, possible burns and even a breakdown.
6. Do not store and use the tool and battery cartridge in locations where the temperature may reach or exceed 50 °C (122 °F).
7. Do not incinerate the battery cartridge even if it is severely damaged or is completely worn out. The battery cartridge can explode in a fire.

8. **Do not nail, cut, crush, throw, drop the battery cartridge, or hit against a hard object to the battery cartridge.** Such conduct may result in a fire, excessive heat, or explosion.
9. **Do not use a damaged battery.**
10. **The contained lithium-ion batteries are subject to the Dangerous Goods Legislation requirements.**

For commercial transports e.g. by third parties, forwarding agents, special requirement on packaging and labeling must be observed. For preparation of the item being shipped, consulting an expert for hazardous material is required. Please also observe possibly more detailed national regulations.

Tap or mask off open contacts and pack up the battery in such a manner that it cannot move around in the packaging.
11. **When disposing the battery cartridge, remove it from the tool and dispose of it in a safe place. Follow your local regulations relating to disposal of battery.**
12. **Use the batteries only with the products specified by Makita.** Installing the batteries to non-compliant products may result in a fire, excessive heat, explosion, or leak of electrolyte.
13. **If the tool is not used for a long period of time, the battery must be removed from the tool.**
14. **During and after use, the battery cartridge may take on heat which can cause burns or low temperature burns. Pay attention to the handling of hot battery cartridges.**
15. **Do not touch the terminal of the tool immediately after use as it may get hot enough to cause burns.**
16. **Do not allow chips, dust, or soil stuck into the terminals, holes, and grooves of the battery cartridge.** It may cause heating, catching fire, burst and malfunction of the tool or battery cartridge, resulting in burns or personal injury.
17. **Unless the tool supports the use near high-voltage electrical power lines, do not use the battery cartridge near high-voltage electrical power lines.** It may result in a malfunction or breakdown of the tool or battery cartridge.
18. **Keep the battery away from children.**

SAVE THESE INSTRUCTIONS.

⚠CAUTION: Only use genuine Makita batteries. Use of non-genuine Makita batteries, or batteries that have been altered, may result in the battery bursting causing fires, personal injury and damage. It will also void the Makita warranty for the Makita tool and charger.

Tips for maintaining maximum battery life

1. Charge the battery cartridge before completely discharged. Always stop tool operation and charge the battery cartridge when you notice less tool power.
2. Never recharge a fully charged battery cartridge. Overcharging shortens the battery service life.

- Charge the battery cartridge with room temperature at 10 °C - 40 °C (50 °F - 104 °F). Let a hot battery cartridge cool down before charging it.
- When not using the battery cartridge, remove it from the tool or the charger.
- Charge the battery cartridge if you do not use it for a long period (more than six months).

NOTE: Depending on the conditions of use and the ambient temperature, the indication may differ slightly from the actual capacity.

NOTE: The first (far left) indicator lamp will blink when the battery protection system works.

Tool / battery protection system

The tool is equipped with a tool/battery protection system. This system automatically cuts off power to the motor to extend tool and battery life. The tool will automatically stop during operation if the tool or battery is placed under one of the following conditions:

FUNCTIONAL DESCRIPTION

CAUTION: Always be sure that the tool is switched off and the battery cartridge is removed before adjusting or checking function on the tool.

Indicating the remaining battery capacity

Press the check button on the battery cartridge to indicate the remaining battery capacity. The indicator lamps light up for a few seconds.

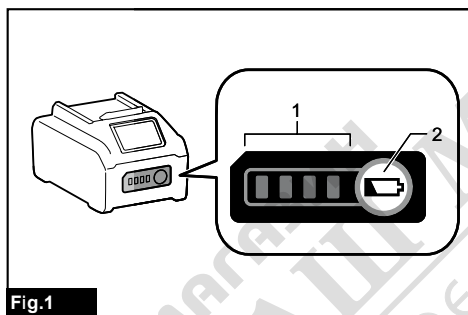

Fig.1

- 1. Indicator lamps 2. Check button

Overload alert function

The overload alert function may work if the current rises sharply due to the operation such as applying too much pressure onto a workpiece.

The overload alert function declines the speed of the oscillation and then increases the amplitude of vibration. In this case, once isolate the application tool from the workpiece, then the speed of the oscillation goes back. Continue operation with an appropriate load.

Overload protection

When the tool/battery is operated in a manner that causes it to draw an abnormally high current, the tool stops automatically. In this situation, turn the tool off and stop the application that caused the tool to become overloaded. Then turn the tool on to restart.

Overheat protection

When the tool/battery is overheated, the tool stops automatically. In this situation, let the tool/battery cool before turning the tool on again.

Overdischarge protection

When the battery capacity is not enough, the tool stops automatically. In this case, remove the battery from the tool and charge the battery.

Protection lock function

When the protection system works repeatedly, the tool is locked. In this situation, the tool does not start even if turning the tool off and on. To release the protection lock, remove the battery, set it to the battery charger and wait until the charging finishes.

Protections against other causes

Protection system is also designed for other causes that could damage the tool and allows the tool to stop automatically. Take all the following steps to clear the causes, when the tool has been brought to a temporary halt or stop in operation.

- Make sure that all switch(es) is/are in the off position, and then turn the tool on again to restart.
- Charge the battery(ies) or replace it/them with recharged battery(ies).
- Let the tool and battery(ies) cool down.

If no improvement can be found by restoring protection system, then contact your local Makita Service Center.

Indicator lamps			Remaining capacity
Lighted	Off	Blinking	
■	□	◐	75% to 100%
■ ■ ■ ■	□ □ □ □	◐ ◐ ◐ ◐	
■ ■ ■ ■	□ □ □ □	◐ ◐ ◐ ◐	50% to 75%
■ ■ ■ ■	□ □ □ □	◐ ◐ ◐ ◐	25% to 50%
■ ■ ■ ■	□ □ □ □	◐ ◐ ◐ ◐	0% to 25%
◐	□ □ □ □	◐ ◐ ◐ ◐	Charge the battery.
■ ■ ■ ■	□ □ □ □	◐ ◐ ◐ ◐	The battery may have malfunctioned.
□ □ □ □	■ ■ ■ ■	◐ ◐ ◐ ◐	

Switch action

CAUTION: Before installing the battery cartridge into the tool, always check to see that the tool is switched off.

To start the tool, slide the slide switch toward the "I (ON)" position.

To stop the tool, slide the slide switch toward the "O (OFF)" position.

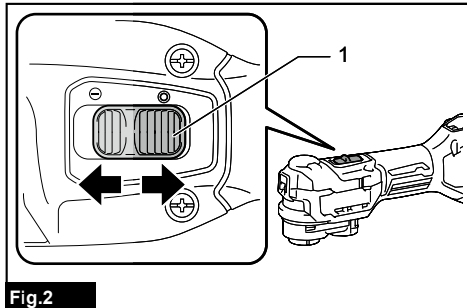

Fig.2

► 1. Slide switch

Adjusting the oscillation rate

The oscillation rate is adjustable. To change the oscillation rate, turn the dial between 1 and 6. The higher the number is, the higher the oscillation rate is. Preset the dial to the number suitable for your workpiece.

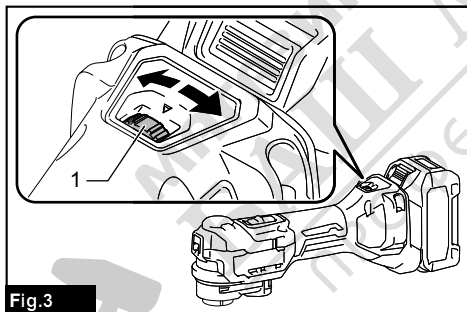

Fig.3

► 1. Dial

NOTE: The dial cannot be turned directly from 1 to 6 or from 6 to 1. Forcing the dial may damage the tool. When changing the dial direction, always turn the dial moving it through each intermediate number.

Lighting up the front lamp

CAUTION: Do not look in the light or see the source of light directly.

Slide the slide switch toward the "I (ON)" position to light up the front lamp. The lamp keeps on lighting while the switch is in the "I (ON)" position.

The front lamp goes out 10 seconds after sliding switch toward the "O (OFF)" position.

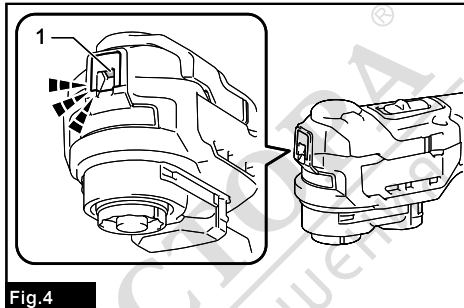

Fig.4

► 1. Front lamp

NOTE: When the overheat protection or the protection lock function is working, the front lamp blinks for about 1 minutes. Refer the section for the tool / battery protection system.

Electronic function

The tool is equipped with the electronic functions for easy operation.

Constant speed control

The speed control function provides the constant oscillation rate regardless of load conditions.

Soft start feature

Soft start feature reduces starting reaction.

Accidental re-start preventive function

When installing the battery cartridge while the slide switch in the "I (ON)" position, the tool does not start. To start the tool, first slide the slide switch toward the "O (OFF)" position and then slide it toward the "I (ON)" position.

ASSEMBLY

Installing or removing battery cartridge

⚠CAUTION: Always switch off the tool before installing or removing of the battery cartridge.

⚠CAUTION: Hold the tool and the battery cartridge firmly when installing or removing battery cartridge. Failure to hold the tool and the battery cartridge firmly may cause them to slip off your hands and result in damage to the tool and battery cartridge and a personal injury.

To install the battery cartridge, align the tongue on the battery cartridge with the groove in the housing and slip it into place. Insert it all the way until it locks in place with a little click. If you can see the red indicator as shown in the figure, it is not locked completely.

To remove the battery cartridge, slide it from the tool while sliding the button on the front of the cartridge.

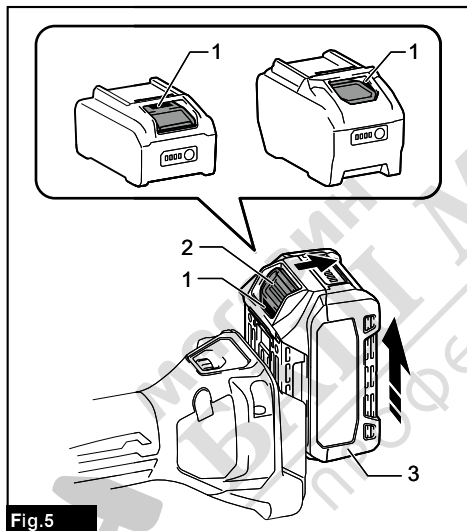

Fig.5

► 1. Red indicator 2. Button 3. Battery cartridge

⚠CAUTION: Always install the battery cartridge fully until the red indicator cannot be seen. If not, it may accidentally fall out of the tool, causing injury to you or someone around you.

⚠CAUTION: Do not install the battery cartridge forcibly. If the cartridge does not slide in easily, it is not being inserted correctly.

⚠CAUTION: Always be sure that the tool is switched off and the battery cartridge is removed before carrying out any work on the tool.

Installing or removing application tool

Optional accessory

⚠WARNING: Do not install application tool upside down. Installing application tool upside down may damage the tool and cause serious personal injury.

⚠CAUTION: Clean up dust and perform lubrication on the moving part of the lock lever from time to time. Otherwise dust may accumulate in the moving part of the lock lever and hinder its smooth movement.

⚠CAUTION: Be careful when closing the lock lever.

Hold the tool firmly when installing or removing the application tool. Do not put your hand around the original position of the lock lever. The lock lever may close suddenly and pinch your finger.

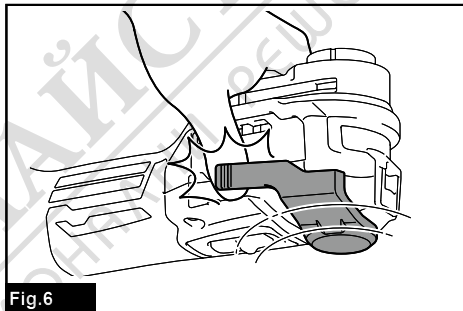

Fig.6

NOTICE: Install application tool in the correct direction according to your work. Application tool can be installed at an angle of every 30 degree.

NOTICE: Do not start the tool while the lever opens. The tool may be damaged.

1. Open the lock lever fully until it sounds a click. Remove the holder bolt.

When the lock lever is fully opened, the position of the lock lever is maintained even if you release your hand.

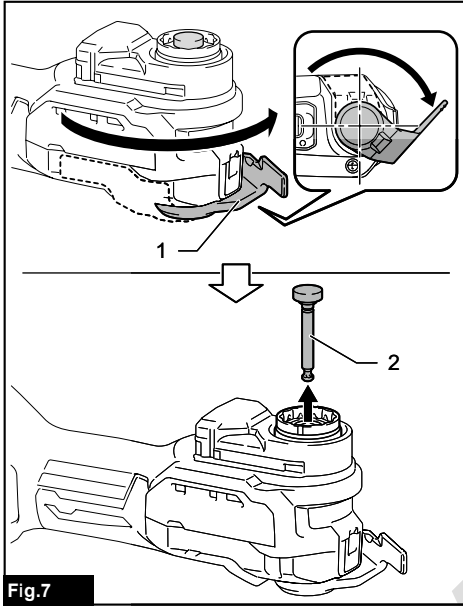

► 1. Lock lever 2. Holder bolt

2. Put an application tool (optional accessory) onto the tool flange. And then, insert the holder bolt until it stops.

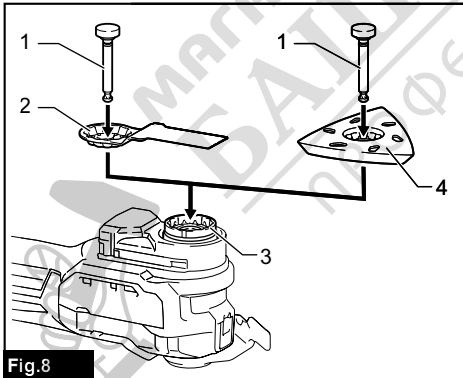

► 1. Holder bolt 2. Application tool 3. Tool flange
4. Application tool (sanding pad)

3. Return the lock lever to its original position.

Always make sure that the application tool is securely held in place.

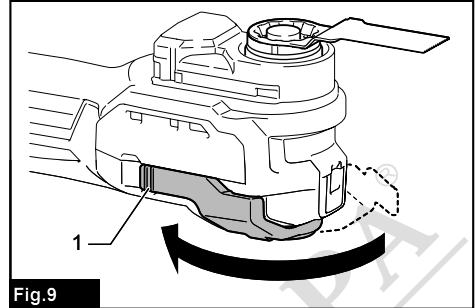

► 1. Lock lever

To remove the application tool, follow the installation procedures in reverse.

CAUTION: When removing the application tool, do not touch the application tool or the workpiece immediately after operation; they may be extremely hot and could burn your skin.

Using sanding application tool

When using sanding application tool, mount the application tool on the sanding pad so that it matches the sanding pad direction.

The sanding pad has a hook and loop type fitting system which allows easy and rapid fitting of a sanding paper.

As sanding papers have holes for dust extraction, mount a sanding paper so that the holes in a sanding paper match those in the sanding pad.

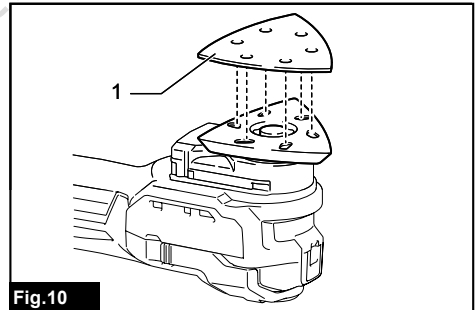

► 1. Sanding paper

To remove a sanding paper, raise its end and peel it off.

OPERATION

⚠WARNING: Before starting the tool and during operation, keep your hand and face away from the application tool.

⚠CAUTION: Do not apply excessive load to the tool which may cause a motor lock and stop the tool.

⚠CAUTION: Do not operate the tool with pressing the battery cartridge against the tool.

NOTICE: If you operate the tool with forcing or excessive pressure, the overload alert may work and then the amplitude of vibration increase.

In this case, once isolate the application tool from the workpiece, then the speed of the oscillation goes back. Continue operation with an appropriate load.

Cutting, sawing and scraping

NOTICE: Do not move on the tool forcibly in the direction (e.g. towards either side) of the application tool with no cutting edge. It may damage the tool.

NOTICE: Operate the tool with appropriate load. Forcing or excessive pressure on the tool may reduce efficiency.

Especially when operating the tool with a long blade (e.g. plunge cut saw blade), applying too much pressure that the blade bends may not only reduce efficiency but also activate the protection system.

Put the application tool on the workpiece. And then move the tool forward so that the application tool movement does not slow down.

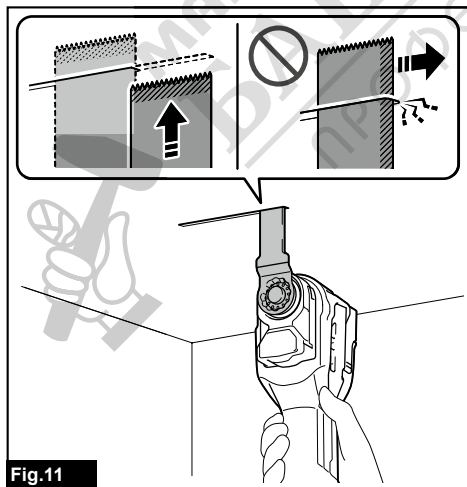

NOTE: Before cutting operation, it is recommended to preset the oscillation rate 4 - 6.

NOTE: An adequate movement speed of the tool makes saw dust ejected smoothly. It helps efficient operation.

NOTE: The round saw is recommended for cutting long straight line.

Sanding

NOTICE: Do not reuse a sanding paper used for sanding metal to sand wood.

NOTICE: Do not use a worn sanding paper or sanding paper without grit.

Apply a sanding paper on the workpiece.

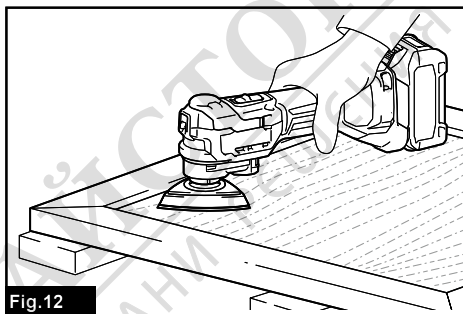

NOTE: Before the operation, it is recommended to determine a suitable oscillation rate by sanding a test material sample as trial.

NOTE: It is recommended not to change the grid of the sanding paper until you finish sanding the whole surface of the workpiece. Changing the grid of the sanding paper on the half way may cause an unfine finish.

Dust attachment for sanding operation

Optional accessory

CAUTION: Do not use the dust extraction attachment when sanding metal. Sucking spark and hot particle results in smoking and ignition.

Installing the dust attachment

1. Remove the holder bolt and the application tool.
2. Put the dust attachment with the latches aligned with the notches on the tool.

Slide the dust attachment as shown in the illustration.

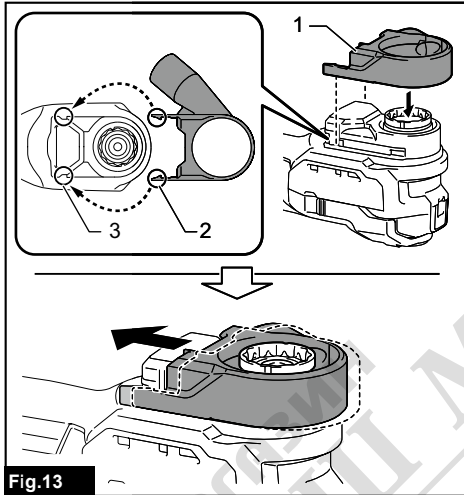

- 1. Dust attachment 2. Latch 3. Notch

3. Install the sanding pad and the holder bolt.
4. Connect the hose of the vacuum cleaner to the dust extraction attachment.

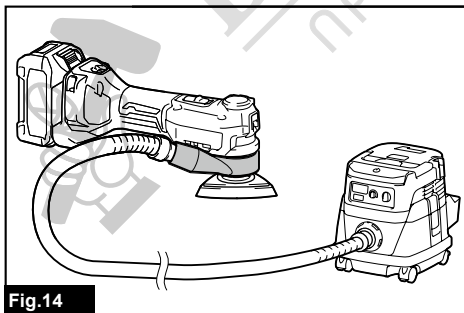

Removing the dust attachment

1. When removing the dust attachment, remove the holder bolt and the sanding pad.
2. Slide the dust attachment while opening the latches by hands as shown in the illustration, and then remove the dust attachment from the tool.

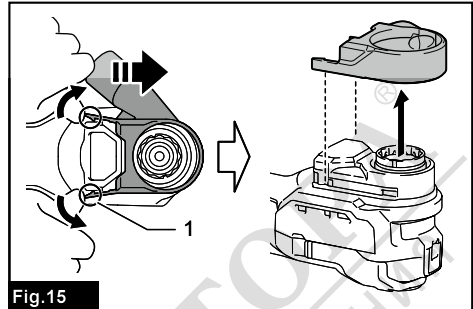

- 1. Latch

MAINTENANCE

CAUTION: Always be sure that the tool is switched off and the battery cartridge is removed before attempting to perform inspection or maintenance.

NOTICE: Never use gasoline, benzine, thinner, alcohol or the like. Discoloration, deformation or cracks may result.

To maintain product SAFETY and RELIABILITY, repairs, any other maintenance or adjustment should be performed by Makita Authorized or Factory Service Centers, always using Makita replacement parts.

OPTIONAL ACCESSORIES

CAUTION: These accessories or attachments are recommended for use with your Makita tool specified in this manual. The use of any other accessories or attachments might present a risk of injury to persons. Only use accessory or attachment for its stated purpose.

If you need any assistance for more details regarding these accessories, ask your local Makita Service Center.

- Segment saw blade
- Round saw blade
- Plunge cut saw blade
- Scraper (rigid)
- Scraper (flexible)
- Serrated seg blade

- General joint cutter
- HM remover
- HM seg saw blade
- HM sanding plate
- Diamond seg sawblade
- Sanding pad
- Abrasive paper delta (red / white / black)
- Fleece delta (medium / coarse / without grit)
- Polishing felt delta
- Dust extraction attachment
- Makita genuine battery and charger

NOTE: Some items in the list may be included in the tool package as standard accessories. They may differ from country to country.



МАГАЗИН
БАШ МАЙСТОРА®
ПРОФЕСИОНАЛНИ РЕШЕНИЯ

МАГАЗИН
БАШ МАЙСТОРА®
ПРОФЕСИОНАЛНИ РЕШЕНИЯ



Makita Europe N.V.

Jan-Baptist Vinkstraat 2, 3070 Kortenberg, Belgium

Makita Corporation

3-11-8, Sumiyoshi-cho, Anjo, Aichi 446-8502 Japan

www.makita.com



885A83-221
EN
20240507