



TE-AC 36/150 Li OF

D	Originalbetriebsanleitung Akku-Kompressor	SLO	Originalna navodila za uporabo Akumulatorski kompresor
GB	Original operating instructions Cordless compressor	H	Eredeti használati utasítás Akkus-Kompresszor
F	Instructions d'origine Compresseur sans fil	RO	Instrucțiuni de utilizare originale Compresor cu acumulator
I	Istruzioni per l'uso originali Compressore a batteria	GR	Πρωτότυπες Οδηγίες χρήσης Συμπιεστής, με μπαταρία
DK/ N	Original betjeningsvejledning Akku-kompressor	P	Manual de instrucções original Compressor sem fio
S	Original-bruksanvisning Batteridrivnen kompressor	HR/ BIH	Originalne upute za uporabu Akumulatorski kompresor
CZ	Originální návod k obsluze Akumulátorový kompresor	RS	Originalna uputstva za upotrebu Akumulatorski kompresor
SK	Originálny návod na obsluhu Akumulátorový kompresor	PL	Instrukcję oryginalną Kompresor akumulatorowy
NL	Originele handleiding Accu compressor	TR	Orijinal Kullanma Talimatı Akülü Kompresör
E	Manual de instrucciones original Compresor inalámbrico	EE	Originaalkasutusjuhend Akukompressor
FIN	Alkuperäiskäyttöohje Akku-kompressori		



Art.-Nr.: 40.204.15

I.-Nr.: 21023

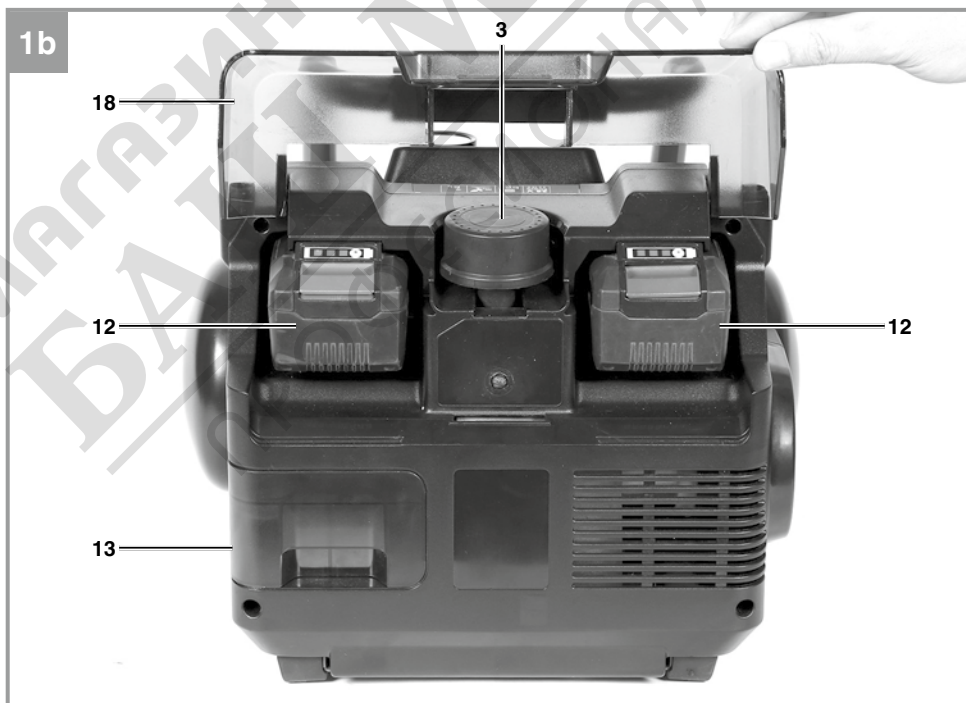
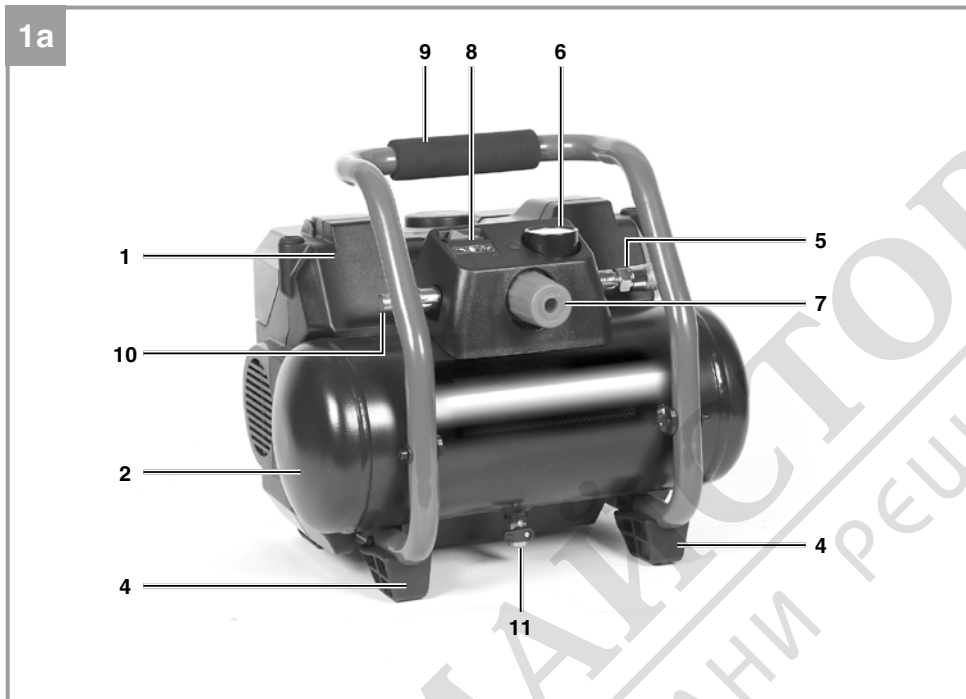

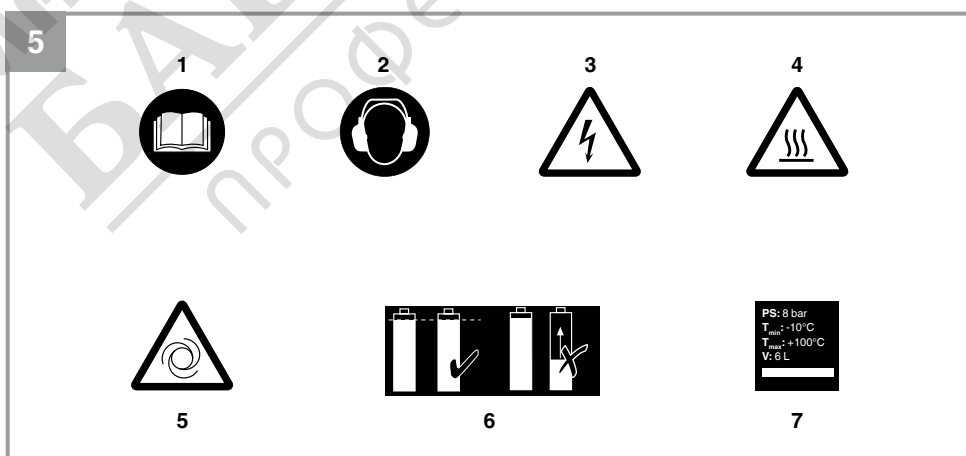
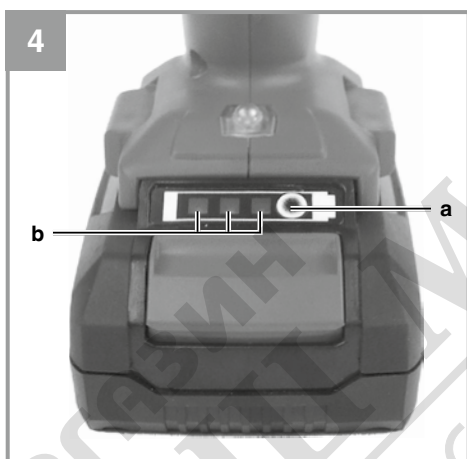
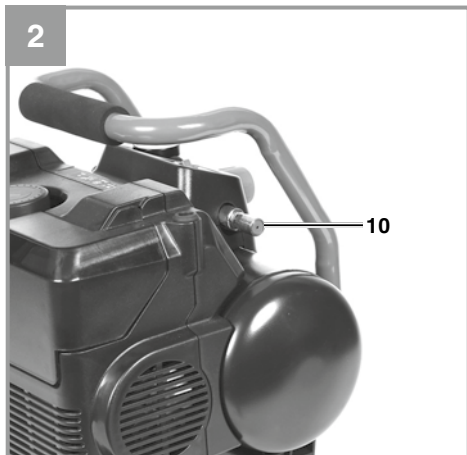

**Danger!**

When using the equipment, a few safety precautions must be observed to avoid injuries and damage. Please read the complete operating instructions and safety regulations with due care. Keep this manual in a safe place, so that the information is available at all times. If you give the equipment to any other person, hand over these operating instructions and safety regulations as well. We cannot accept any liability for damage or accidents which arise due to a failure to follow these instructions and the safety instructions.

**Explanation of the symbols used (see Fig. 5)**

1. **Danger!** - Read the operating instructions to reduce the risk of inquiry
2. **Caution! Wear ear-muffs.** The impact of noise can cause damage to hearing.
3. **Beware of electrical voltage!**
4. **Beware of hot parts!**
5. **Warning!** The unit will start up automatically without warning if the pressure drops below cut-in pressure!
6. **Important!** Use only batteries which are charged to the same level. Never combine full and half-full batteries.
7. **PS:** Max. operating pressure  
 $T_{max}$ : Max. operating temperature  
 $T_{min}$ : Min. operating temperature  
**V:** Tank capacity

**1. Safety regulations**

The corresponding safety information can be found in the enclosed booklet.

**Warning!**

**Read all the safety information, instructions, illustrations and technical data provided on or with this power tool.** Failure to adhere to the following instructions may result in electric shock, fire and/or serious injury.

**Keep all the safety information and instructions in a safe place for future use.**

This appliance is not intended for use by persons (including children) with reduced physical, sensory or mental capabilities, or lack of experience and knowledge, unless they have been given supervision or instruction concerning use of the appliance by a person responsible for their safety. Children should be supervised to ensure that they do not play with the appliance.

**2. Layout and items supplied****2.1 Layout (Fig. 1/2)**

1. Housing cover
2. Pressure tank
3. Intake air filter
4. Foot
5. Quick-lock coupling (regulated compressed air)
6. Pressure gauge (for reading the set pressure)
7. Pressure regulator
8. ON/OFF switch
9. Transport handle
10. Safety valve
11. Drainage cock for condensation water
12. Battery pack (not supplied)
13. Storage compartment for 8-piece adapter set
14. Battery cover

**2.2 Items supplied**

Please check that the article is complete as specified in the scope of delivery. If parts are missing, please contact our service center or the sales outlet where you made your purchase at the latest within 5 working days after purchasing the product and upon presentation of a valid bill of purchase. Also, refer to the warranty table in the service information at the end of the operating instructions.

- Open the packaging and take out the equipment with care.
- Remove the packaging material and any packaging and/or transportation braces (if available).
- Check to see if all items are supplied.
- Inspect the equipment and accessories for transport damage.
- If possible, please keep the packaging until the end of the guarantee period.

**Danger!**

**The equipment and packaging material are not toys. Do not let children play with plastic bags, foils or small parts. There is a danger of swallowing or suffocating!**

- Original operating instructions
- Safety information

**3. Proper use**

The cordless compressor is designed to generate compressed air for compressed air driven tools.

The equipment is to be used only for its prescribed purpose. Any other use is deemed to be a case of misuse. The user / operator and not the manufacturer will be liable for any damage or injuries of any kind caused as a result of this.

Please note that our equipment has not been designed for use in commercial, trade or industrial applications. Our warranty will be voided if the machine is used in commercial, trade or industrial businesses or for equivalent purposes.

#### 4. Technical data

Mains voltage .....	36 V DC
Compressor speed min <sup>-1</sup> : .....	3200
Operating pressure bar: .....	max. 8
Pressure vessel capacity (in liters): .....	6
Theoretical suction rate l/min.: .....	150
Output (compressed air) at 7 bar: ....	50 liters/min
Output (compressed air) at 4 bar: ....	70 liters/min
Sound power level L <sub>WA</sub> in dB: .....	94
Uncertainty K <sub>WA</sub> .....	2.23 dB
Sound pressure level L <sub>pA</sub> in dB: .....	73
Uncertainty K <sub>pA</sub> .....	2.23 dB
Protection type: .....	IPX0
Weight of the unit in kg: .....	approx. 10.5

This equipment is supplied without batteries and without a charger and is allowed to be used only with lithium-ion batteries and chargers from the Power X-Change series!

Please note that the equipment's performance will be limited if it is used with batteries of type Power X-Change 18V 1.5Ah or Power X-Change 18V 2.0 Ah: With these batteries the compressor will not reach the final cut-out pressure of 8 bar. The batteries will switch off before reaching the final pressure (at approx. 4 bar).

#### **Danger!** **Noise**

The noise emission values were measured in accordance with EN ISO 3744.

#### 5. Before starting the equipment

Before you connect the equipment to the power supply make sure that the data on the rating plate

are identical to those of the rechargeable battery.

- Check the equipment for damage which may have occurred in transit. Report any damage immediately to the transport company which was used to deliver the compressor.
- Install the compressor in the vicinity of the point of consumption.
- Avoid long air lines.
- Make sure that the intake air is dry and dust-free.
- Do not install the compressor in a damp or wet room.
- The compressor may only be used in suitable rooms (with good ventilation and an ambient temperature from +5 °C to 40 °C). There must be no dust, acids, vapors, explosive gases or inflammable gases in the room.
- The compressor is designed to be used in dry rooms. It is prohibited to use the compressor in areas where work is conducted with sprayed water.
- Operate the equipment only on a firm, level surface.
- Use flexible hoses in order to prevent transmitting unacceptable loads to the pipeline system at the connection between the compressor system and the pipeline system.
- It is essential to use separators, traps and drains which process the liquids produced by the compressor before the compressor system is put into operation.
- Supply hoses at pressures above 7 bar should be equipped with a safety cable (e.g. a wire rope).

#### 5.1 Charging the battery (Fig. 3)

1. Take the battery pack out of the equipment. Do this by pressing the side pushlock buttons.
2. Check that your mains voltage is the same as that marked on the rating plate of the battery charger. Insert the power plug of the charger (d) into the socket outlet. The green LED will then begin to flash.
3. Slot the battery pack (12) onto the battery charger (d).
4. In the section entitled „Charger indicator“ you will find a table with an explanation of the LED indicator on the charger.

The battery pack can become a little warm during the charging. This is normal.

If the battery pack fails to charge, check:

- whether there is voltage at the socket outlet
- whether there is good contact at the charging contacts

If the battery pack still fails to charge, send

- the charger
- and the battery pack

to our customer service center.

**To ensure that items are properly packaged and delivered when you send them to us, please contact our customer service or the point of sale at which the equipment was purchased.**

**When shipping or disposing of batteries and cordless tools, always ensure that they are packed individually in plastic bags to prevent short circuits and fires.**

To ensure that the battery pack provides long service, you should take care to recharge it promptly. You must recharge the battery pack when you notice that the performance of the device drops. Never allow the battery pack to become fully discharged. This will cause it to develop a defect.

**Important!**

Use only batteries which are charged to the same level. Never combine full and half-full batteries. Always charge the two batteries simultaneously.

The equipment's operating time depends on the battery with the lower charge level. The two batteries must always be fully charged before use. Close the battery cover by swinging it down, and make sure that it latches in place correctly.

**Installing the battery (Fig. 1b)**

Flip up the battery cover (18) as shown in Figure 1b. Slot the two rechargeable batteries (12) into the mounts.

**Battery capacity indicator (Fig. 4)**

Press the battery capacity indicator switch (a). The battery capacity indicator (b) will indicate the charge status of the battery by means of 3 LEDs.

**All 3 LEDs are lit:**

The battery is fully charged.

**2 or 1 LED(s) are lit:**

The battery has an adequate remaining charge.

**1 LED flashes:**

The battery is empty, recharge the battery.

**All LEDs blink:**

The battery temperature is too low. Remove the battery from the equipment, keep it at room temperature for one day. If the fault reoccurs, this means that the rechargeable battery has undergone exhaustive discharge and is defective. Remove the battery from the equipment. Never use or charge a defective battery.

## 6. Assembly and starting

**Important!**

**You must fully assemble the equipment before using it for the first time.**

**6.1 On/Off switch (Fig. 1a)**

To switch on the equipment, set the On/Off switch (8) to position 1.

To switch off the equipment, move the On/Off switch (8) to position 0.

**6.2 Setting the pressure (Fig. 1a)**

- You can adjust the pressure on the pressure gauge (6) using the pressure regulator (7).
- The set pressure can be drawn from the quick-lock coupling (5).

**6.3 Setting the pressure switch**

The pressure switch is set at the factory.

Cut-in pressure approx. 6 bar

Cut-out pressure approx. 8 bar

## 7. Cleaning, maintenance and ordering of spare parts

**Hazard!**

**Remove the rechargeable batteries before doing any cleaning and maintenance work.**

**Warning!**

**Wait until the compressor has completely cooled down. Risk of burns!**

**Warning!**

**Always depressurize the tank before carrying out any cleaning and maintenance work.**

**Warning!**

**After use, always switch off the equipment immediately and pull out the rechargeable batteries.**

**7.1 Cleaning**

- Keep the safety devices free of dirt and dust as far as possible. Wipe the equipment with a clean cloth or blow it with compressed air at low pressure.
- We recommend that you clean the appliance immediately after you use it.
- Clean the appliance regularly with a damp cloth and some soft soap. Do not use cleaning agents or solvents; these may be aggressive to the plastic parts in the appliance. Ensure that no water can get into the interior of the appliance.
- You must disconnect the hose and any spraying tools from the compressor before cleaning. Do not clean the compressor with water, solvents or the like.

**7.2 Condensed water (Fig. 1)**

**Important!** To ensure a long service life of the pressure vessel (2), drain off the condensed water by opening the drainage cock (11) each time after using.

Check the pressure vessel for signs of rust and damage each time before using. Do not use the compressor with a damaged or rusty pressure vessel. If you discover any damage, please contact the customer service workshop.

**7.3 Safety valve (10)**

The safety valve has been set for the highest permitted pressure of the pressure vessel. It is prohibited to adjust the safety valve or remove its seal. Actuate the safety valve from time to time to ensure that it works when required. To do so, open the screw cap of the valve while the tank is under pressure. Once the screw cap has been fully opened you must pull it to let air escape through the valve. Then screw the cap fully back in place.

**7.4 Cleaning the intake filter (3)**

The intake filter prevents dust and dirt being drawn in. It is essential to clean this filter after at least every 300 hours in operation. A clogged intake filter will decrease the compressor's performance dramatically. Open the halves of the air filter housing. Use compressed air at low pressure (approx. 3 bar) to blow out all the parts of the filter and then assemble the filter in reverse order. When cleaning, take adequate precautions

against dust (e.g. use a suitable face mask).

**7.5 Storage****Warning!**

Pull out the rechargeable batteries and ventilate the equipment and all connected pneumatic tools. Switch off the compressor and make sure that it is secured in such a way that it cannot be started up again by any unauthorized person.

**Warning!**

**Store the compressor only in a dry location which is not accessible to unauthorized persons. Always store upright, never tilted!**

**7.6 Transport**

- Transport the equipment only by carrying it by the transport handle.
- Protect the equipment against unexpected knocks and vibrations.

**7.7 Ordering replacement parts:**

Please quote the following data when ordering replacement parts:

- Type of machine
- Article number of the machine
- Identification number of the machine
- Replacement part number of the part required

For our latest prices and information please go to [www.Einhell-Service.com](http://www.Einhell-Service.com)

**8. Disposal and recycling**

The equipment is supplied in packaging to prevent it from being damaged in transit. The raw materials in this packaging can be reused or recycled. The equipment and its accessories are made of various types of material, such as metal and plastic. Never place defective equipment in your household refuse. The equipment should be taken to a suitable collection center for proper disposal. If you do not know the whereabouts of such a collection point, you should ask in your local council offices.

## 9. Charger indicator

Indicator status		Explanations and actions
Red LED	Green LED	
Off	Flashing	<p><b>Ready for use</b> The charger is connected to the mains and is ready for use; there is no battery pack in the charger</p>
On	Off	<p><b>Charging</b> The charger is charging the battery pack in quick charge mode. The charging times are shown directly on the charger. <b>Important!</b> The actual charging times may vary slightly from the stated charging times depending on the existing battery charge.</p>
Off	On	<p><b>The battery is charged and ready for use. (READY TO GO)</b> The unit then changes over to gentle charging mode until the battery is fully charged. To do this, leave the rechargeable battery on the charger for approx. 15 minutes longer. <b>Action:</b> Take the battery pack out of the charger. Disconnect the charger from the mains supply.</p>
Flashing	Off	<p><b>Adapted charging</b> The charger is in gentle charging mode. For safety reasons the charging is performed less quickly and takes more time. The reasons can be: - The rechargeable battery has not been used for a very long time. - The battery temperature is outside the ideal range. <b>Action:</b> Wait for the charging to be completed; you can still continue to charge the battery pack.</p>
Flashing	Flashing	<p><b>Fault</b> Charging is no longer possible. The battery pack is defective. <b>Action:</b> Never charge a defective battery pack. Take the battery pack out of the charger.</p>
On	On	<p><b>Temperature fault</b> The battery pack is too hot (e.g. due to direct sunshine) or too cold (below 0° C). <b>Action:</b> Remove the battery pack and keep it at room temperature (approx. 20° C) for one day .</p>

## 10. Possible causes of failure

Problem	Cause	Solution
The compressor does not start.	<ol style="list-style-type: none"> <li>1. No power supply</li> <li>2. Outside temperature is too low.</li> <li>3. Motor is overheated.</li> </ol>	<ol style="list-style-type: none"> <li>1. Check the rechargeable batteries</li> <li>2. Never operate with an outside temperature of below +5° C.</li> <li>3. Allow the motor to cool down. If necessary, remedy the cause of the overheating.</li> </ol>
The compressor starts but there is no pressure.	<ol style="list-style-type: none"> <li>1. The non-return valve leaks.</li> <li>2. The seals are damaged.</li> <li>3. The drainage cock for condensation water has a leak.</li> </ol>	<ol style="list-style-type: none"> <li>1. Have a service center replace the non-return valve.</li> <li>2. Check the seals and have any damaged seals replaced by a service center.</li> <li>3. Check the drainage cock and replace if necessary.</li> </ol>
The compressor starts, pressure is shown on the pressure gauge, but the tools do not start.	<ol style="list-style-type: none"> <li>1. The hose connections have a leak.</li> <li>2. A quick-lock coupling has a leak.</li> <li>3. Insufficient pressure set on the pressure regulator.</li> </ol>	<ol style="list-style-type: none"> <li>1. Check the compressed air hose and tools and replace if necessary.</li> <li>2. Check the quick-lock coupling and replace if necessary.</li> <li>3. Increase the set pressure with the pressure regulator.</li> </ol>

### Disposal



Power tools, rechargeable batteries, accessories and packaging should be sorted for environmental-friendly recycling.

Do not dispose of power tools and batteries/rechargeable batteries into household waste!

#### Only for EU countries:

According to the Directive 2012/19/EU on waste electrical and electronic equipment and its transposition into national law, power tools that are no longer usable, and, according to the Directive 2006/66/EC, defective or drained batteries must be collected separately and disposed of in an environmentally correct manner.

If disposed incorrectly, waste electrical and electronic equipment may have harmful effects on the environment and human health, due to the potential presence of hazardous substances.

#### Only for United Kingdom:

According to The Waste Electrical and Electronic Equipment Regulations 2013 (SI 2013/3113) (as amended) and the Waste Batteries and Accumulators Regulations 2009 (SI 2009/890) (as amended), products that are no longer usable must be collected separately and disposed of in an environmentally friendly manner.

The reprinting or reproduction by any other means, in whole or in part, of documentation and papers accompanying products is permitted only with the express consent of the Einhell Germany AG.

Subject to technical changes

## Service information

We have competent service partners in all countries named on the guarantee certificate whose contact details can also be found on the guarantee certificate. These partners will help you with all service requests such as repairs, spare and wearing part orders or the purchase of consumables.

Please note that the following parts of this product are subject to normal or natural wear and that the following parts are therefore also required for use as consumables.

Category	Example
Wear parts*	Battery
Consumables*	
Missing parts	

\* Not necessarily included in the scope of delivery!

In the effect of defects or faults, please register the problem on the internet at [www.Einhell-Service.com](http://www.Einhell-Service.com). Please ensure that you provide a precise description of the problem and answer the following questions in all cases:

- Did the equipment work at all or was it defective from the beginning?
- Did you notice anything (symptom or defect) prior to the failure?
- What malfunction does the equipment have in your opinion (main symptom)? Describe this malfunction.

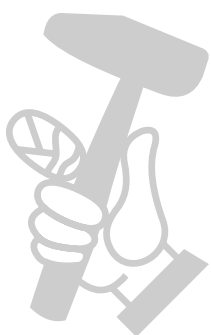

## Warranty certificate

Dear Customer,

All of our products undergo strict quality checks to ensure that they reach you in perfect condition. In the unlikely event that this equipment develops a fault, please contact our service department at the address shown on this guarantee card. You can also contact us by telephone using the service number shown. Please note the following terms under which guarantee claims can be made:

1. These guarantee terms apply solely to consumers, i.e. natural persons, who do not want to use this product in connection with either their commercial or other self-employed activities. These guarantee terms regulate additional guarantee services which the undermentioned manufacturer promises to buyers of its new products in addition to their statutory rights of guarantee. Your statutory rights of guarantee are not affected by this guarantee. Our guarantee is free of charge to you.
2. The guarantee services cover only defects due to material or manufacturing faults on the new product which you have bought in the European Union from the undermentioned manufacturer and are limited to either the rectification of said defects or the replacement of the product, whichever we prefer. Please note that only equipment under the brand name "Professional" has been designed for use in commercial, trade or professional applications. For all other products the guarantee is invalidated if the equipment is used within the guarantee period in commercial, trade or industrial applications or for other equivalent activities.
3. Our guarantee does not cover:
  - Damage to the equipment caused by failure to comply with the installation/assembly instructions or by unprofessional installation; damage caused by failure to comply with the operating instructions (e.g. connection to the wrong mains voltage or current type); damage caused by failure to comply with the maintenance and safety regulations; damage caused by exposing the equipment to abnormal environmental conditions; damage resulting from poor care and maintenance.
  - Damage to the equipment caused by misuse or incorrect applications (e.g. overloading the equipment or using non-approved attachments or accessories); damage caused by foreign bodies (e.g. sand, stones, dust, ...) getting inside the equipment. Damage in transit; damage caused by force or external influences (e.g. by dropping the equipment).
  - Damage to the equipment or parts of the equipment which is owed to use-related, normal or otherwise natural wear. For example, batteries and battery packs are manufactured with a cycle limit for design-related reasons. Wear is negatively influenced in particular by load demands and charging speeds as well as exposure to heat, cold, vibration and impact.
4. The guarantee is valid for a period of 2 years starting from the purchase date of the equipment. Guarantee claims must be submitted before the end of the guarantee period and within two weeks of the defect being noticed. No guarantee claims will be accepted after the end of the guarantee period. The original guarantee period remains applicable to the equipment even if repairs are carried out or parts are replaced. In such cases, the work performed or parts fitted will not result in an extension of the guarantee period, and no new guarantee will become active for the work performed or for any replacement parts fitted. This also applies if on-site service is used.
5. To assert your guarantee claim, register the defective equipment at: [www.Einhell-Service.com](http://www.Einhell-Service.com). You will need to provide proof of purchase of the new item of equipment. Equipment returned without such proof or without a rating plate are excluded from the guarantee services because of the lack of traceability. If the defect is covered by our guarantee, then either the item in question will be repaired immediately and returned to you or we will send you a new replacement.
6. If you have taken the equipment with you to a different EU country than where you bought it, we will arrange for a local service partner to provide the guarantee services. If you take the equipment outside the EU, the guarantee will not apply.

Of course, we are also happy to offer a chargeable repair service for any defects which are not covered or no longer covered by the scope of this guarantee. To take advantage of this service, please send the equipment to our service address. We draw attention to the restrictions of this guarantee concerning wear parts, consumables and missing parts as presented in the service information included in this operating manual.

Warrantor/ Service:

Einhell UK Ltd, Unit 10, 1st Floor, Champion's Business Park, Arrowe Brook Road, Upton, Wirral, CH49 0UQ